



# INSTALLATION INSTRUCTIONS

**57-2560**

**FORD / MAZDA**

**2004-08 Ranger / B3000**

**V6-3.0L**

**NOTE:** This kit was not designed to fit vehicles with a body lift.

**TOOLS NEEDED:**

- Flat Blade Screwdriver
- Pliers
- 5/8 Wrench
- 10mm Wrench
- Ratchet
- Extension
- 10mm Socket
- 13mm Socket
- 14mm Socket
- Drill
- 5/8" Drill Bit

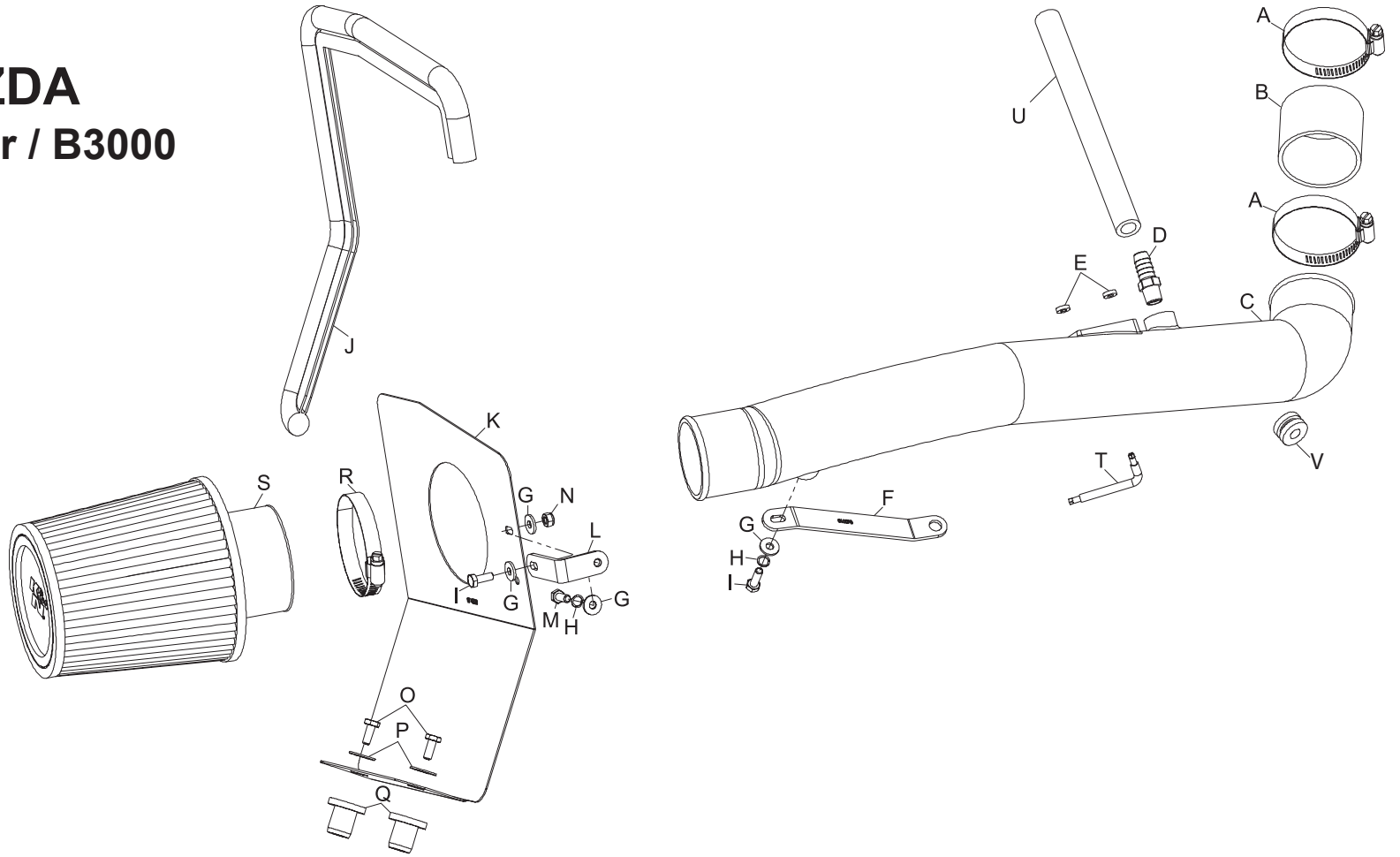

**PARTS LIST:**

Description	Qty.	Part #	Description	Qty.	Part #	Description	Qty.	Part #
A Hose Clamp #36	2	08530	I Bolt; 6mm-1.00x16mm, Hex	2	07703	Q Insert; 3/8-16x3/4x5/16L Rubber	2	08163
B Silicone Hose	1	08405	J Edge Trim 26"	1	102488	R Hose Clamp # 40	1	08554
C Intake Tube	1	087130	K Heat Shield	1	074028	S Air Filter	1	RX-4860
D Vent; 1/4" NPT-1/2" Barb	1	080022	L Bracket "L"	1	070932	T Wrench; Torx T20 T/R	1	69801
E Spacer;.437"Odx.200"Idx.115"	2	06503	M Bolt; 6mm-1.00 X 20mm, Hex	1	07865	U Hose; 1/2"ID X 14"L	1	08402
F Bracket "Z"	1	010078	N Nut; 6mm Nylock	1	07553	V Grommet	1	08100
G Washer; 1/4"Id X 5/8"OD, Flat	4	08275	O Bolt; 3/8-16 X 1.25", Hex Head	2	07779			
H Washer; 1/4" Split Lock	2	08198	P Washer; 3/8", Flat	2	08134			

**NOTE: FAILURE TO FOLLOW INSTALLATION INSTRUCTIONS AND NOT USING THE PROVIDED HARDWARE MAY DAMAGE THE INTAKE TUBE, THROTTLE BODY AND ENGINE.**

**TO START:**

1. Turn off the ignition and disconnect the negative battery cable.  
**NOTE: Disconnecting the negative battery cable erases pre-programmed electronic memories. Write down all memory settings before disconnecting the negative battery cable. Some radios will require an anti-theft code to be entered after the battery is reconnected. The anti-theft code is typically supplied with your owner's manual. In the event your vehicles' anti-theft code cannot be recovered, contact an authorized dealership to obtain your vehicles anti-theft code.**

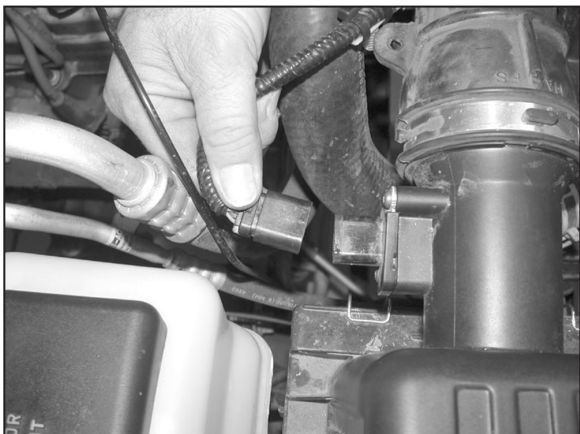

2. Disconnect the mass air electrical connection, and then disconnect wiring harness from intake tube.

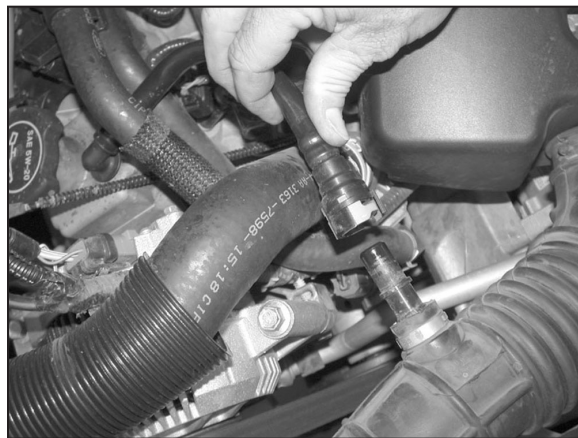

3. Rotate the green locking tab counter clockwise, and then disconnect the crankcase vent from the intake tube as shown.

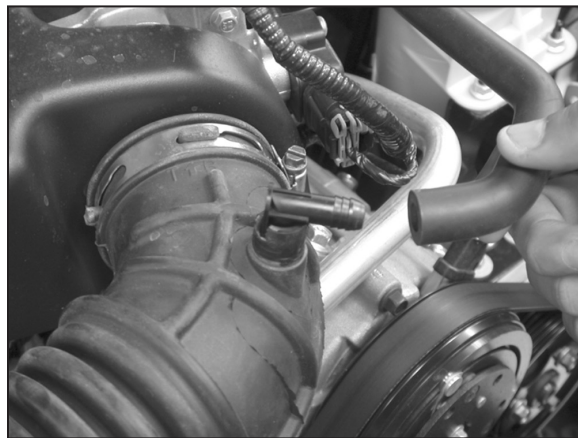

3a. On vehicles equipped with a brake booster breather line, disconnect the breather line from the factory 90° fitting as shown.



3b. Cut the clamp which secures the 90° fitting to the stock intake hose and then remove the fitting as shown.



4. Loosen the hose clamps at the throttle body and the factory airbox, and then remove the intake tube from the vehicle as shown.



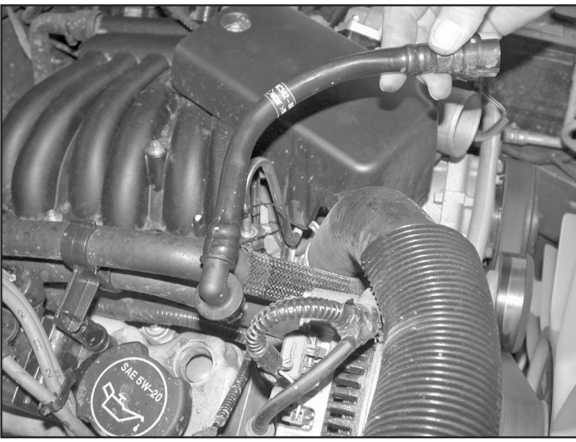

5. Remove crankcase vent tube from valve cover as shown.



6. Slide a flat blade screwdriver in between the airbox and the airbox mounting tray. Pry downward on the tray, while pulling upwards on the airbox assembly to release the assembly from the retaining grommets in the tray.

**NOTE: K&N Engineering, Inc., recommends that customers do not discard factory air intake.**



7. Pull firmly on the air inlet duct to release the duct from the radiator core support as shown.

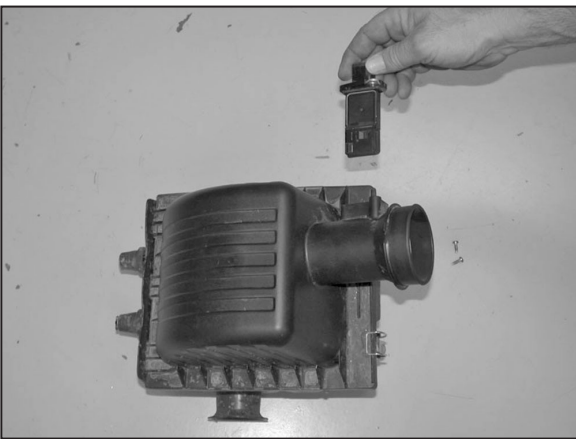

8. Remove the two mass air retaining screws with the torx wrench provided, and then remove the mass air sensor as shown.

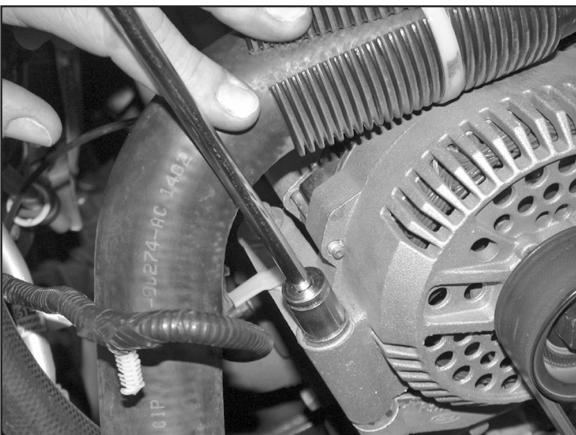

9. Loosen and remove the lower front alternator hex bolt as shown.

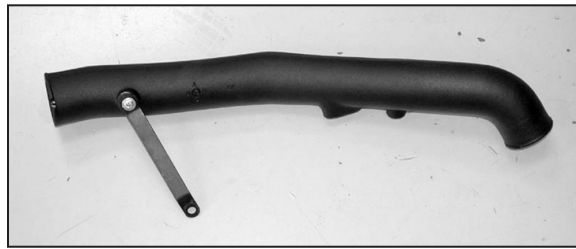

10. Mount the tube-mounting bracket (010078) onto the new K&N® intake tube with the provided hardware as shown.

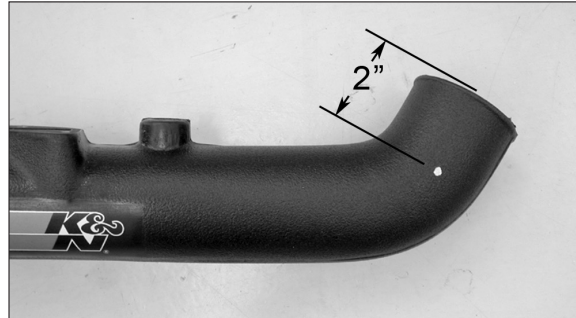

10a. On vehicles equipped with a brake booster breather line, measure 2.0" from the outlet end of the tube and mark the location to be drilled.



10b. On vehicles equipped with a brake booster breather line, drill a 5/8" id hole into the K&N® intake tube at the location marked in step #10a and install the provided grommet.

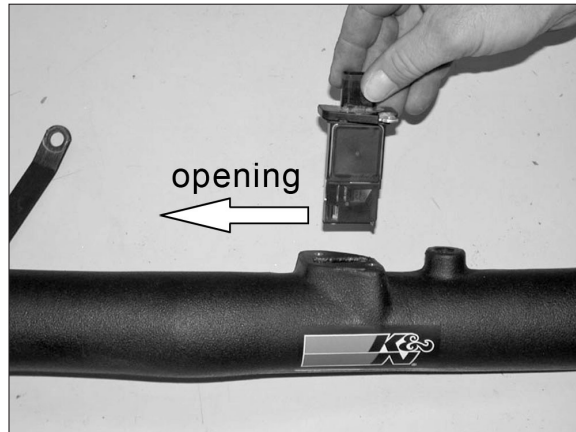

11. Install the mass air sensor into the K&N® intake tube with the open end of the sensor pointed towards the filter end of the tube.



12. Secure the mass air sensor with the factory retaining screws removed in step #8 and spacers provided.



13. Install the vent fitting into the new intake tube as shown.  
**NOTE: Plastic NPT fittings are easy to cross thread. Install the vent fitting "hand" tight, then turn it two complete turns with a wrench.**

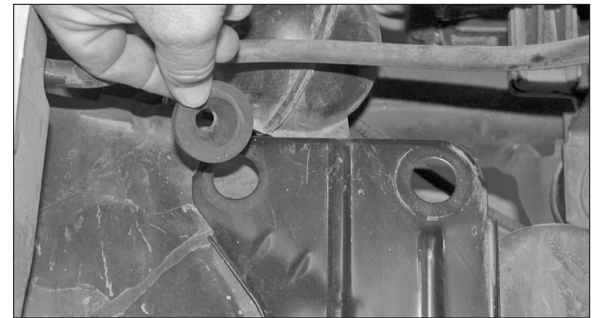

14. Remove the two airbox mounting grommets from the airbox mounting bracket as shown.



15. Install the provided silicone hose (08405) onto the throttle body as shown.



16. Install the intake tube onto the throttle body, then using the bolt removed in step #9 secure the bracket onto the alternator as shown.



16a. On vehicles equipped with a brake booster breather line, install the factory 90° fitting removed in step #3b into the grommet installed into the K&N® intake tube in step #10b.



16b. On vehicles equipped with a brake booster breather line, connect the vent line to the 90° fitting installed in step #16a.

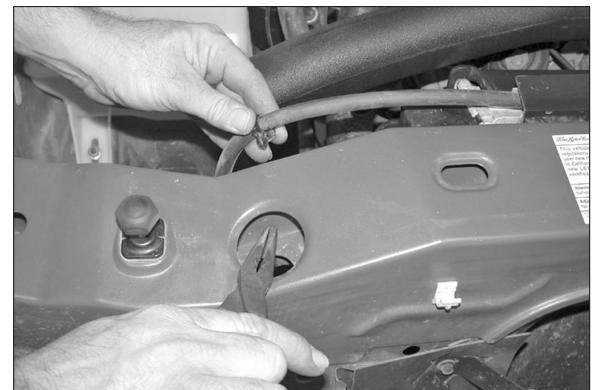

17. Using small pliers, squeeze the cooling system reservoir hose-retaining clip through the large hole in the top of the core support, and then remove the clip from the radiator core support.



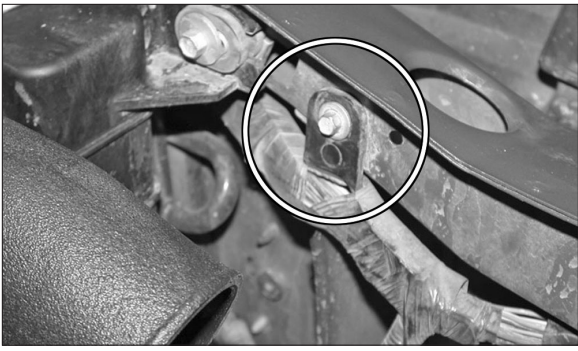

18. Remove the wiring harness mounting bolt shown from the radiator core support.



19. Install the edge trim onto the heat shield as shown. Trim if needed.



20. Install the "L" bracket (070932) onto the heat shield as shown, with the provided hardware.  
**NOTE: Do not completely tighten at this time.**

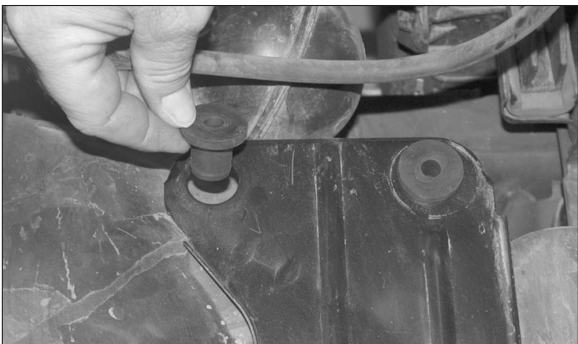

21. Install the threaded inserts to the airbox mounting bracket as shown.



22. Install the heat shield into the vehicle using the 3/8" bolts and washers provided threaded into the inserts installed in step #21.

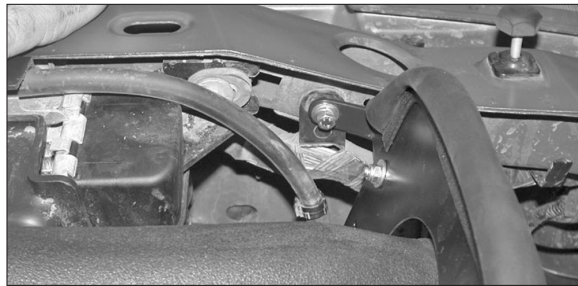

23. Fasten the heat shield mounting bracket to the core support with the bolt and lock washer provided passing through the wiring harness mount into the core support as shown.

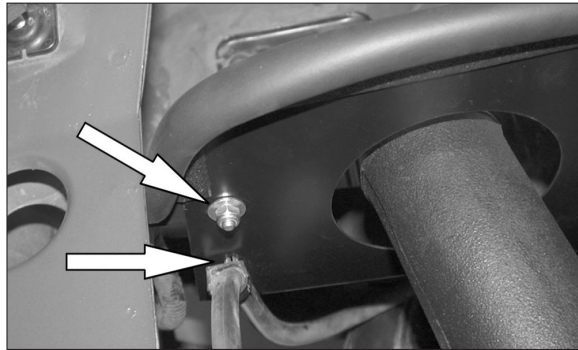

24. Attach the coolant reservoir house clip to the heat shield as shown.



25. Using a razor blade slit the plastic tube and then remove the tube from the valve cover fitting as shown.



26. Attach the provided silicone hose (08402) onto the valve cover fitting as shown.



27. Re-install the valve cover fitting into the valve cover and then attach the silicone hose onto the K&N® intake tube as shown.

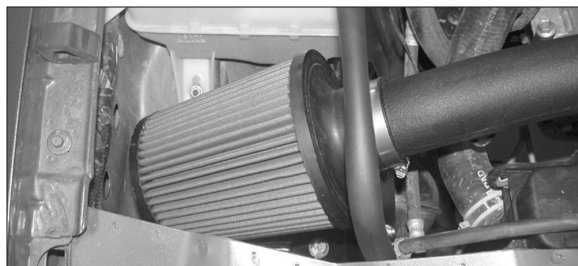

28. Install the K&N® air filter onto the intake tube and secure with the provided hose clamp as shown.

**NOTE: Drycharger® air filter wrap; part # RX-4730DK is available to purchase separately.**

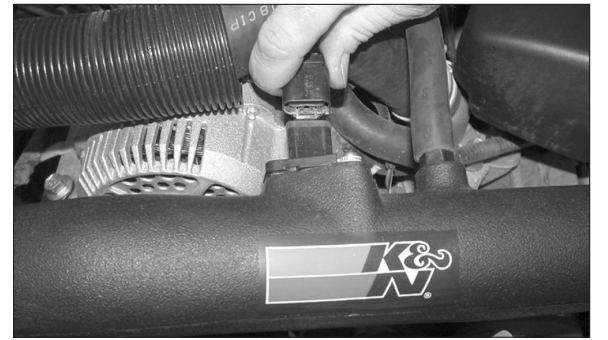

29. Reconnect the mass air electrical connection as shown.



30. Reconnect the vehicle's negative battery cable. Double check to make sure everything is tight and properly positioned before starting the vehicle.

31. The C.A.R.B. exemption sticker, (attached), must be visible under the hood so that an emissions inspector can see it when the vehicle is required to be tested for emissions. California requires testing every two years, other states may vary.

32. It will be necessary for all K&N® high flow intake systems to be checked periodically for realignment, clearance and tightening of all connections. Failure to follow the above instructions or proper maintenance may void warranty.

#### ROAD TESTING:

1. Start the engine with the transmission in neutral or park, and the parking brake engaged. Listen for air leaks or odd noises. For air leaks secure hoses and connections. For odd noises, find cause and repair before proceeding. This kit will function identically to the factory system except for being louder and much more responsive.

2. Test drive the vehicle. Listen for odd noises or rattles and fix as necessary.

3. If road test is fine, you can now enjoy the added power and performance from your kit.

4. K&N Engineering, Inc., requires cleaning the intake system's air filter element every 100,000 miles. When used in dusty or off-road environments, our filters will require cleaning more often. We recommend that you visually inspect your filter once every 25,000 miles to determine if the screen is still visible. When the screen is no longer visible some place on the filter element, it is time to clean it. To clean and re-oil, purchase our filter Recharger® service kit, part number 99-5050 or 99-5000 and follow the easy instructions.