



# INSTALLATION INSTRUCTIONS

57-2553

FORD

2003 Crown Victoria

V8-4.6L

**TOOLS NEEDED:**

- flat blade Screwdriver
- short extension
- 10mm socket
- 11mm socket
- 5mm allen wrench
- 1/4 ratchet
- 5/32 allen
- 1/4 extension
- 10mm wrench
- 8mm socket
- ratchet

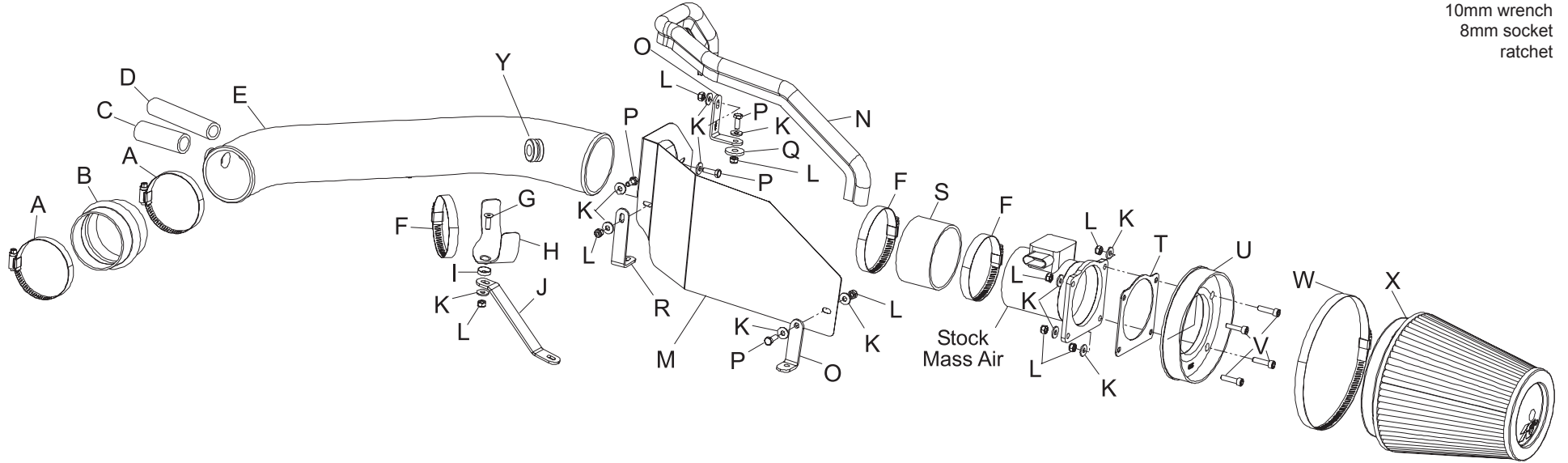

**PARTS LIST:**

Description	Qty.	Part #	Description	Qty.	Part #	Description	Qty.	Part #
A Hose Clamp #44	2	08577	J Bracket	1	071000	S Silicone Hose	1	08690
B Silicone Hump Hose	1	087121	K Washer 1/4"ID x 5/8"OD	12	08275	T Gasket; Mass Air Sensor	1	09330
C Vent Hose 3/4"ID	1	08471	L Nut Nylock 6mm	9	07553	U Filter Adaptor #200	1	08831
D Vent Hose 5/8"ID	1	08538	M Heat Shield	1	074010	V Bolt 6mm-1x25MM Allen	4	07859
E Intake Tube (CU)	1	087088	N Edge Trim 30"L	1	102489	W Hose Clamp #104	1	08697
F Hose Clamp #48	3	08601	O Bracket Short "L"	2	07879	X Air Filter	1	RF-1041
G Bolt 6mm-1.00 F/H/A	1	08376	P Bolt 6mm-1.00x16mm	4	07703	Y Grommet	1	08064
H Saddle Clamp	1	078855	Q Fender Washer	1	08160			
I Cup Washer, Black Nylon	1	08180	R Bracket Long "L"	1	07093			

**NOTE: FAILURE TO FOLLOW INSTALLATION INSTRUCTIONS AND NOT USING THE PROVIDED HARDWARE MAY DAMAGE THE INTAKE TUBE, THROTTLE BODY AND ENGINE.**

**TO START:**

1. Turn off the ignition and disconnect the negative battery cable.  
**NOTE: Disconnecting the negative battery cable erases pre-programmed electronic memories. Write down all memory settings before disconnecting the negative battery cable. Some radios will require an anti-theft code to be entered after the battery is reconnected. The anti-theft code is typically supplied with your owner's manual. In the event your vehicles' anti-theft code cannot be recovered, contact an authorized dealership to obtain your vehicles anti-theft code.**



2. Loosen and remove the bolt that retains the engine cover to the engine with a 1/4 extension, then remove engine cover.



3. Disconnect the mass air sensor electrical connection.

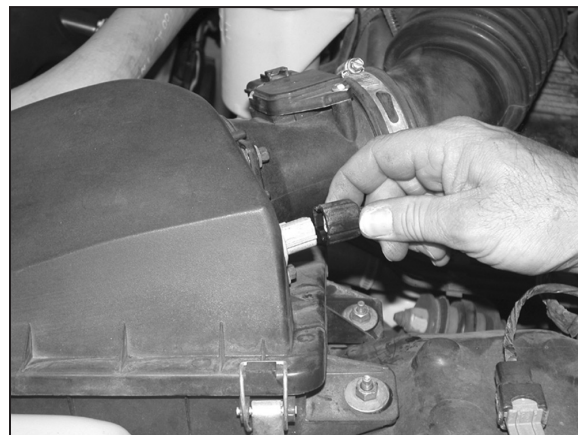

4. Disconnect the temp sensor electrical connection.  
**NOTE: Not all vehicles come with external temp sensors.**



5. Disconnect the crankcase vent and idle air hoses as shown.



6. Loosen the hose clamp at the throttle body and at the mass air sensor then remove the stock air intake tube as shown.

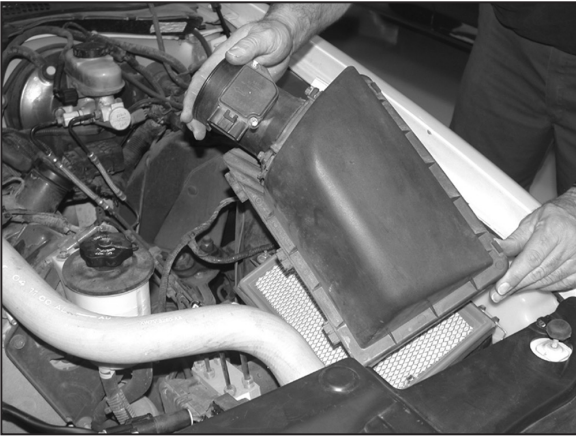

7. Release the 2 clips which retain the air box lid, then remove the lid and filter from the vehicle.

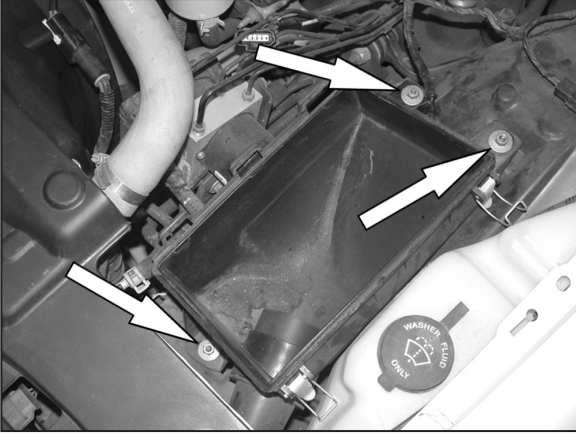

8. Remove the three 11mm bolts that retain the air box bottom to vehicle.

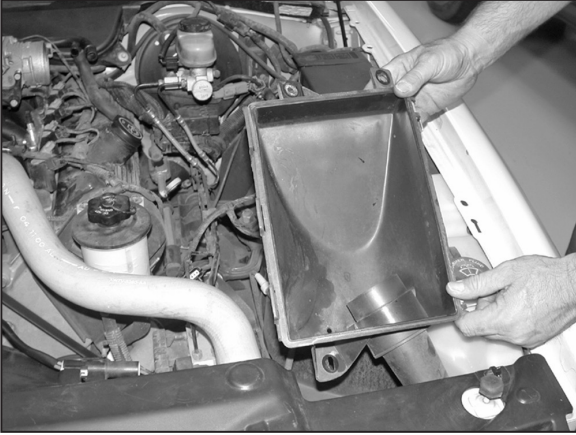

9. Remove air box bottom from vehicle as shown. **NOTE: K&N Engineering, Inc., recommends that customers do not discard factory air intake.**

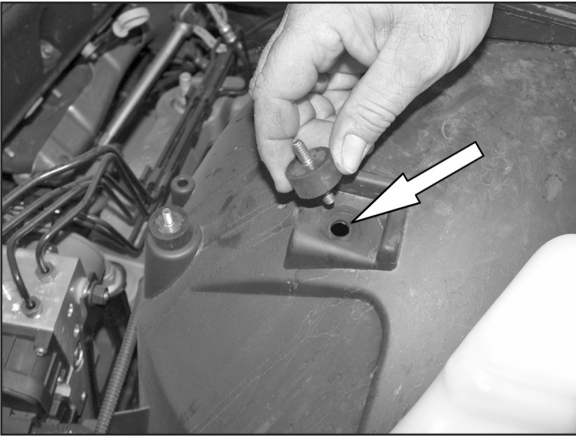

10. Remove the upper rubber mounted stud from the inner fender well as shown.

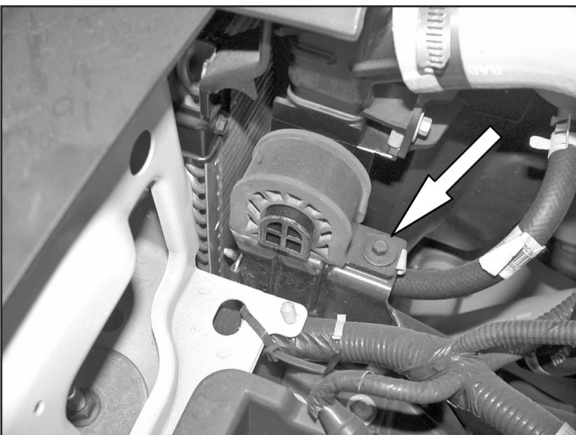

11. Remove radiator support mount bolt as shown.

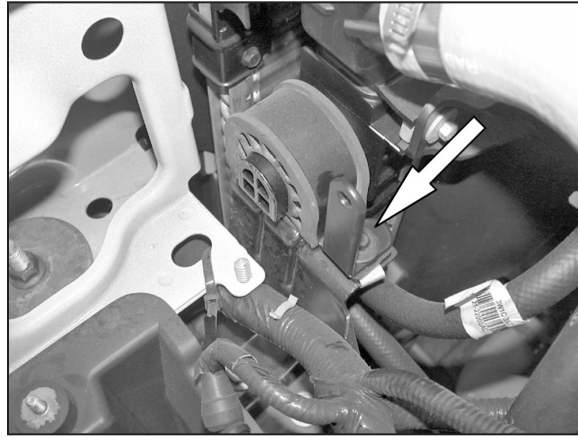

12. Using the bolt that was removed in the previous step install bracket (07879) onto the radiator support as shown.

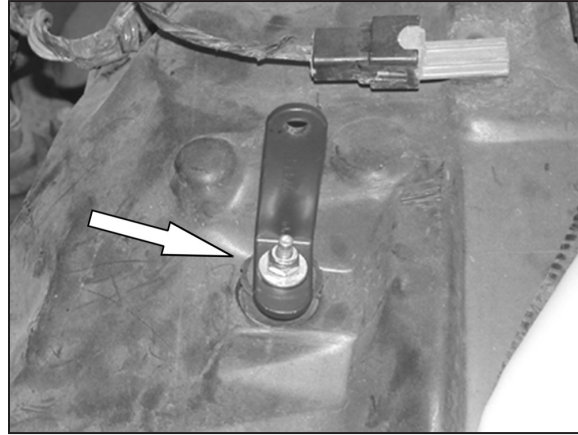

13. Install the provided bracket (07879) onto the inner wheel well as shown.

**NOTE: Install provided fender washer under wheel well when installing bracket.**



14. Install edge trim onto heat shield as shown. Trim if needed.

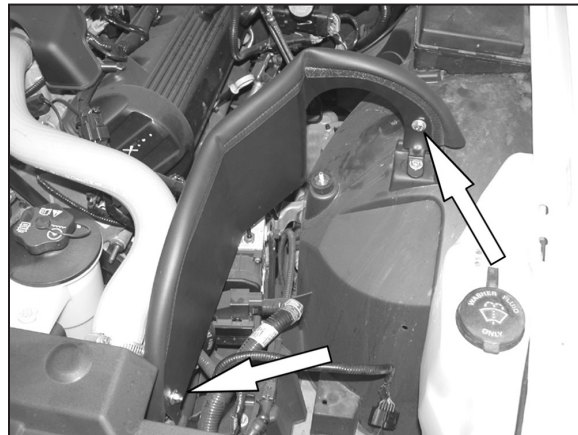

15. Install the heat shield onto the vehicle and attach to the outer brackets as shown.



16. Using the provided hardware, assemble the saddle bracket assembly as shown.



17. Install the saddle bracket assembly and the provided bracket (07093) onto the rubber mounted stud using the factory nut that was removed in step 8. onto vehicle as shown.

**NOTE: Mount bracket above heat shield bracket, then secure with factory nut.**



18. On vehicles that come with external temp sensor drill out the drill point with a 3/4 drill, then install the provided grommet as shown.



19. Install the provided silicone hump hose (087121) onto the K&N® intake tube with the provided hose clamps.



20. Install the K&N® intake onto the throttle body, then secure the tube to the saddle bracket assembly with the provided hose clamp. **NOTE: Do not tighten completely.**

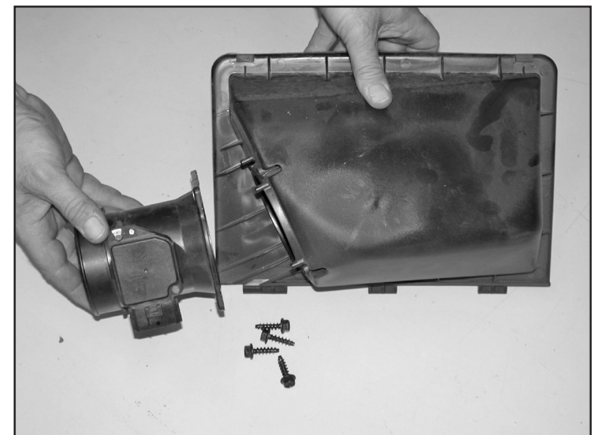

21. Remove the four bolts that retain the mass air sensor to the air box lid, then remove the mass air sensor from lid.

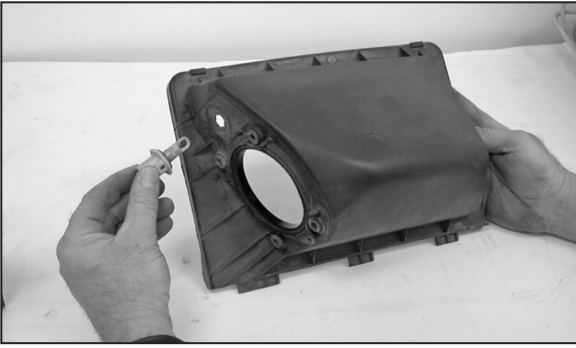

22. On vehicles that come equipped with an external temp sensor, twist counter clockwise to remove from air box lid.



23. Assemble the filter adaptor onto the mass air sensor with the provided hardware as shown.

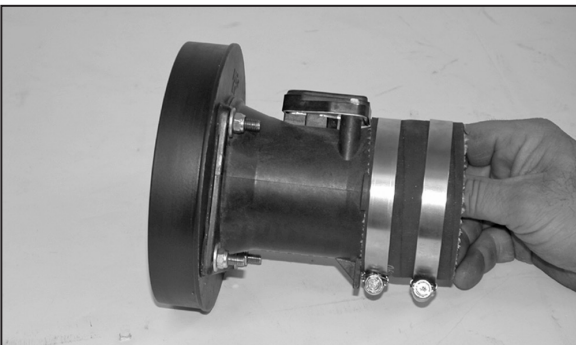

24. Install the silicone hose (08690) onto the mass air sensor with provided hose clamps as shown.



25. Install the air filter onto the mass air assembly as shown.



26. Reconnect the mass air sensor electrical connection as shown.



27. Install the mass air assembly onto the intake tube and adjust for best fit before tightening hose clamps.



28. On vehicles with external temp sensor, install the temp sensor onto the intake tube then re-connect the electrical connection.



29. Reconnect the crankcase vent and idle air hose onto the new intake tube with the provided silicone hoses as shown.



30. Re-install the engine cover that was removed in step 2.



31. Reconnect the vehicle's negative battery cable. Double check to make sure everything is tight and properly positioned before starting the vehicle.

32. The C.A.R.B. exemption sticker, (attached), must be visible under the hood so that an emissions inspector can see it when the vehicle is required to be tested for emissions. California requires testing every two years, other states may vary.

33. It will be necessary for all K&N® high flow intake systems to be checked periodically for realignment, clearance and tightening of all connections. Failure to follow the above instructions or proper maintenance may void warranty.

#### ROAD TESTING:

1. Start the engine with the transmission in neutral or park, and the parking brake engaged. Listen for air leaks or odd noises. For air leaks secure hoses and connections. For odd noises, find cause and repair before proceeding. This kit will function identically to the factory system except for being louder and much more responsive.

2. Test drive the vehicle. Listen for odd noises or rattles and fix as necessary.

3. If road test is fine, you can now enjoy the added power and performance from your kit.

4. K&N Engineering, Inc., requires cleaning the intake system's air filter element every 100,000 miles. When used in dusty or off-road environments, our filters will require cleaning more often. We recommend that you visually inspect your filter once every 25,000 miles to determine if the screen is still visible. When the screen is no longer visible some place on the filter element, it is time to clean it. To clean and re-oil, purchase our filter Recharger® service kit, part number 99-5050 or 99-5000 and follow the easy instructions.