



# INSTALLATION INSTRUCTIONS

**57-2550**

**FORD**

**1997-04 F-150**

**V6-4.2L**

**NOTE:** This kit was not designed to fit vehicles with a body lift.

**TOOLS NEEDED:**

- 2.5mm Allen
- 4mm Allen
- Ratchet
- Extension
- 10mm Socket
- 14mm Socket
- 10mm Wrench
- 5/8 Wrench
- Flat Blade Scredriver

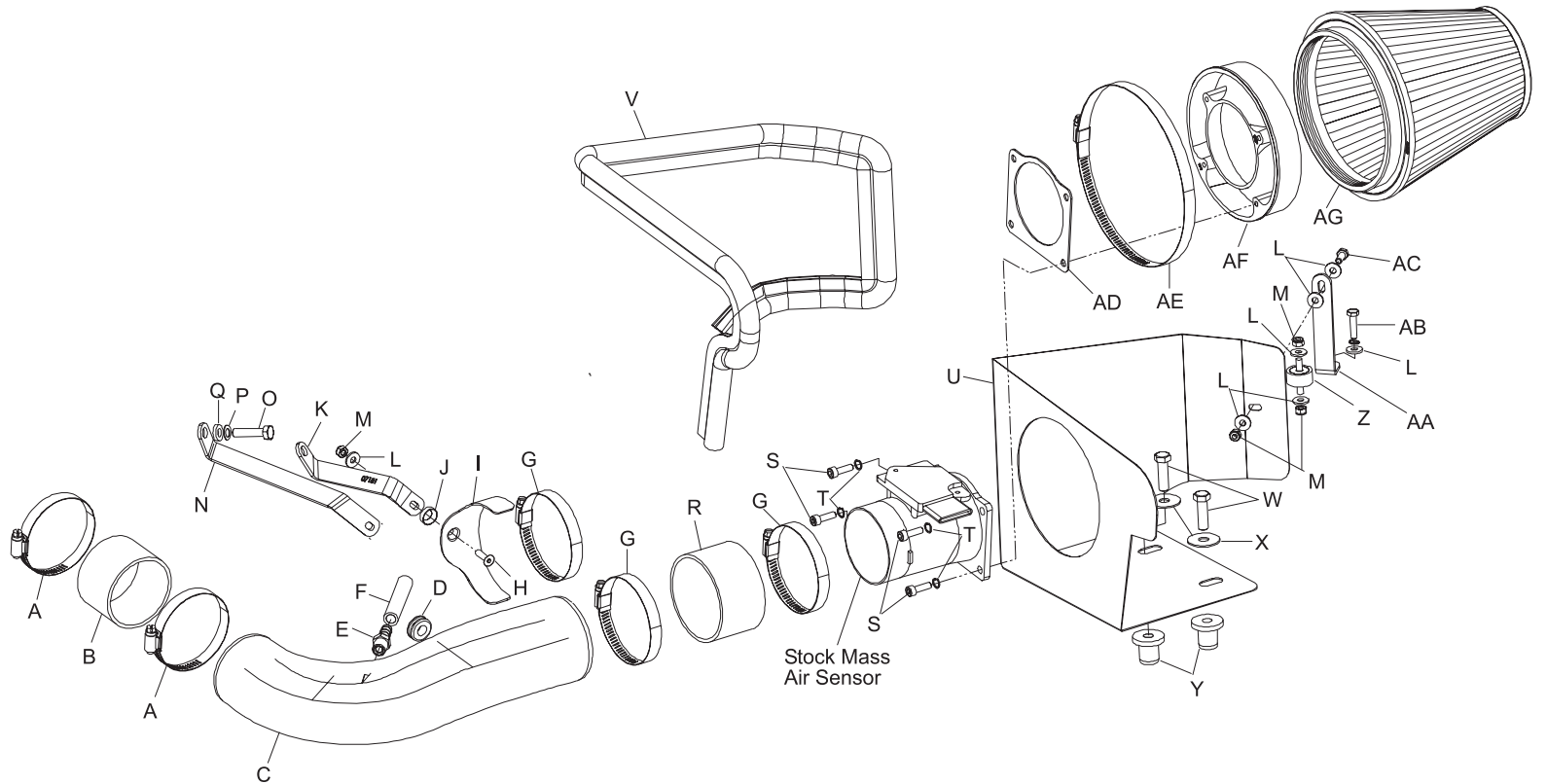

**PARTS LIST:**

Description	Qty.	Part #	Description	Qty.	Part #	Description	Qty.	Part #
A hose clamp #44	2	08560	L washer flat 1/4" x 5/8"od	7	08275	W bolt; 3/8" x 1.25	2	07779
B silicone hose, 2.75" id x 2." L black	1	08756	M nut 6mm nylock	4	07553	X fender washer	2	08126
C intake tube (DB)	1	087096	N bracket, lg Z	1	07180	Y insert, 3/8	2	08163
D grommet, 7/16" id	1	08092	O bolt 8mmx1.25x35mm	1	07784	Z rubber mntd stud m6-1.00m/m	1	07027
E vent; str, 3/8" hose, 1/4" npt	1	08047	P wave washer 8mm	1	08239	AA bracket, "L" long	1	070952
F silicone hose; 3/8" id x 3" l black	1	08462	Q flat washer 5/16"	1	08276	AB bolt 6mmx25mm	1	07704
G hose clamp #48	3	08601	R silicone hose, 3.25" id x 2." l black	1	08690	AC bolt 6mmx 16mm	1	07703
H bolt; 6mm-1.00 x 20mm f/h/a	1	08376	S bolt 6mm-1.00x20mm	4	07852	AD mass air gasket	1	09330
I saddle clamp	1	078855	T washer 1/4" lock	5	08198	AE hose clamp # 104	1	08697
J washer; conical, nylon, black	1	08180	U heat shield	1	07483	AF filter adapter #290	1	21504
K bracket, sm Z	1	07181	V edge trim 55"l	1	102480	AG filtercharger	1	RC-5046

**NOTE: FAILURE TO FOLLOW INSTALLATION INSTRUCTIONS AND NOT USING THE PROVIDED HARDWARE MAY DAMAGE THE INTAKE TUBE, THROTTLE BODY AND ENGINE.**

**TO START:**

1. Turn off the ignition and disconnect the negative battery cable.  
**NOTE: Disconnecting the negative battery cable erases pre-programmed electronic memories. Write down all memory settings before disconnecting the negative battery cable. Some radios will require an anti-theft code to be entered after the battery is reconnected. The anti-theft code is typically supplied with your owner's manual. In the event your vehicles' anti-theft code cannot be recovered, contact an authorized dealership to obtain your vehicles anti-theft code.**



2. Disconnect the air temp sensor electrical connection.

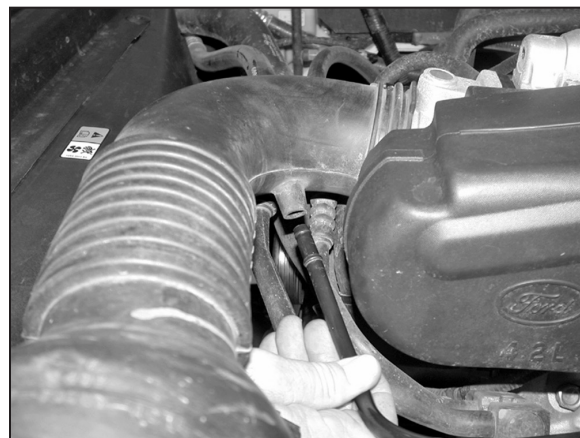

3. Disconnect the crank case vent from intake tube as shown.

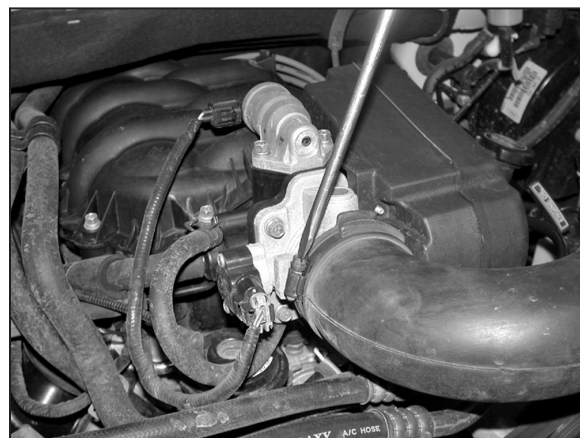

4. Loosen hose clamp at the throttle body.

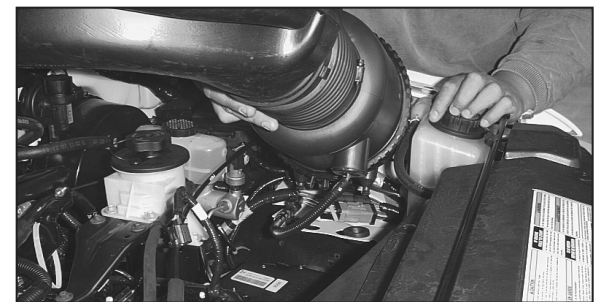

5. Detach the stock intake tube from the throttle body and lift up on the air cleaner assembly to release it from its retaining grommets.



6. Disconnect the secondary mass air sensor electrical connection.



7. Remove the entire stock air intake assembly from the vehicle.



8. Open the air cleaner assembly and isolate the mass air sensor assembly.



9. Slide the rubber grommet back and disconnect the primary mass air sensor electrical connection, using a flat blade screwdriver.



10. Using a flat blade screwdriver, push in and release the four clips that retain the mass air sensor retaining plate.

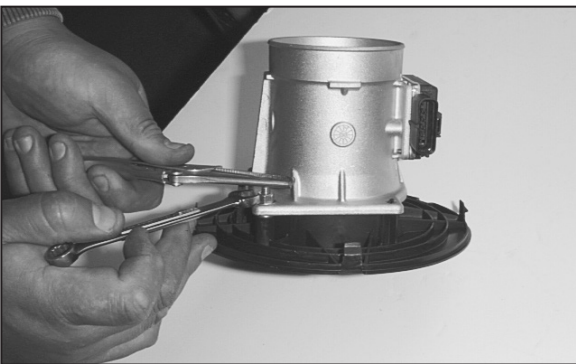

11. Using a pair of small vise grips or pliers, hold the stud while using a 10mm wrench to loosen the nuts, then remove the mass air sensor from the retaining plate.



12. Remove the two air box mounting grommets from vehicle as shown.



13. Install edge trim onto heat shield as shown. Trim if needed.



14. Remove the 6mm bolt that retains the cruise control onto vehicle.



14a. On vehicles without cruise control, install the rubber mounted stud onto vehicle as shown.



15. Install the provided "L" bracket (070952) onto heat shield as shown.

**NOTE: Install a washer between heat shield and bracket.**

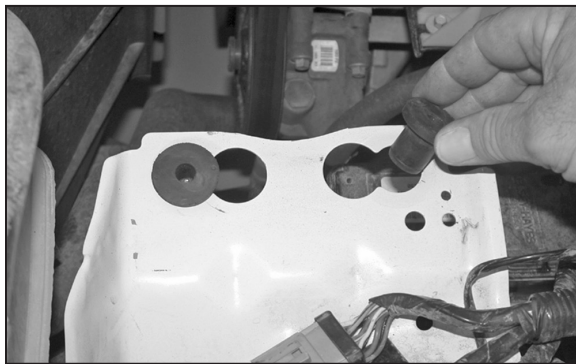

16. Install the two nut inserts onto the air box mounting tray as shown.

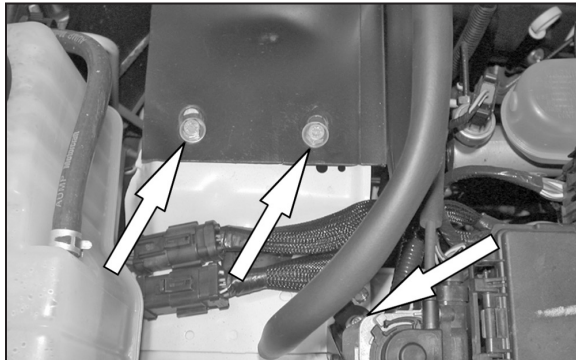

17. On vehicles with cruise control install heat shield as shown with the provided hardware.



17a. On vehicles that did not come equipped with cruise control, install heat shield onto the vehicle, then secure with the provided hardware.

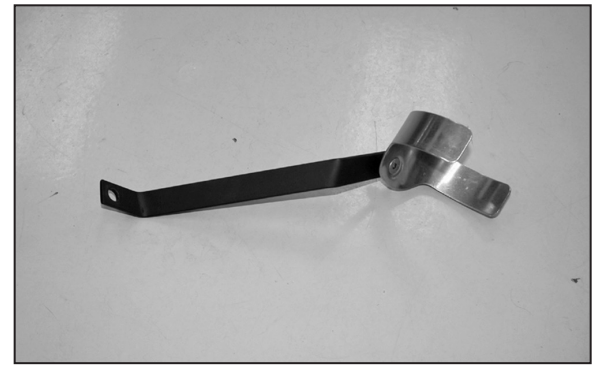

18. On vehicles that did not come equip with A/C, assemble the saddle bracket assembly as shown using bracket (07180).

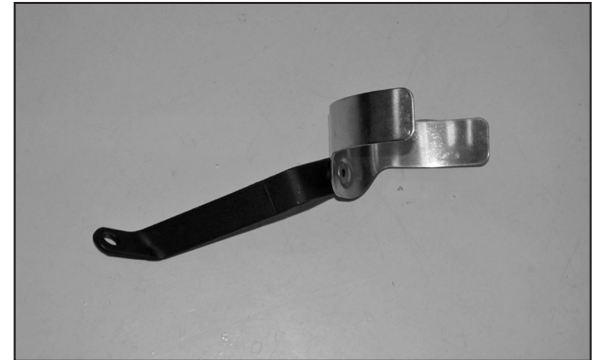

18a. On vehicles that come equip with A/C, assemble the saddle bracket assembly as shown using bracket (07181).



19. On vehicles that come equip with A/C, remove the A/C mounting bolt. Then secure saddle bracket assembly from step 18a onto vehicle with the bolt that was removed.



19a. On non A/C vehicles, install the saddle bracket assembly from step 18 onto vehicle with the provided hardware as shown.

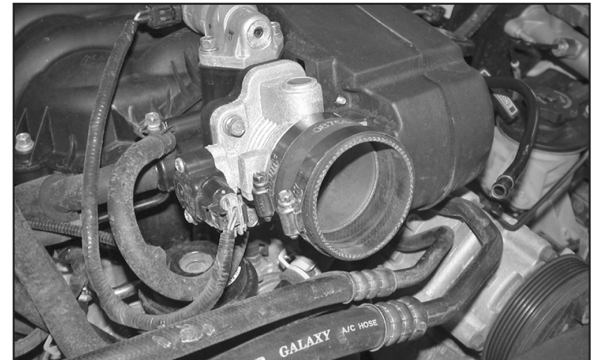

20. Install the provided silicone hose (08756) onto the throttle body with the provided hose clamps.

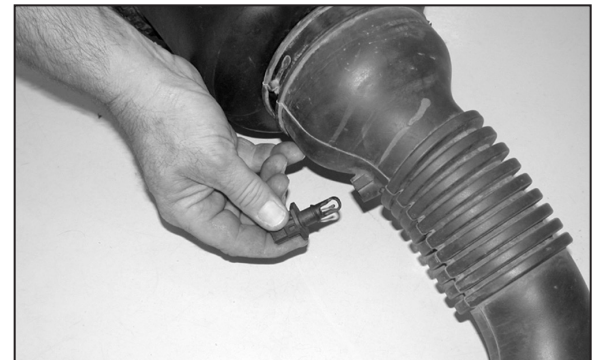

21. Remove the temp sensor from the stock intake tube as shown.

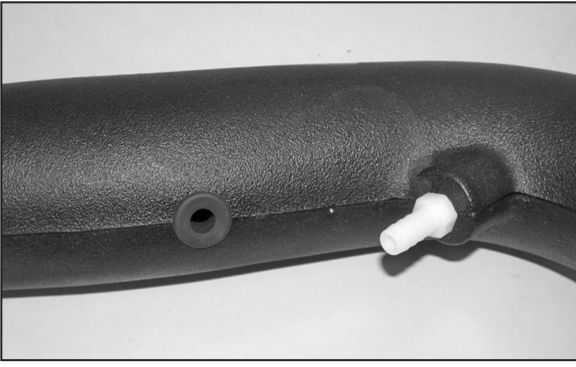

22. Install the provided grommet and vent fitting onto the new K&N® intake tube as shown.  
**NOTE: Plastic NPT fittings are easy to cross thread. Install the vent fitting “hand” tight, then turn it two complete turns with a wrench.**



23. Install the temp sensor into the new K&N® intake tube as shown.

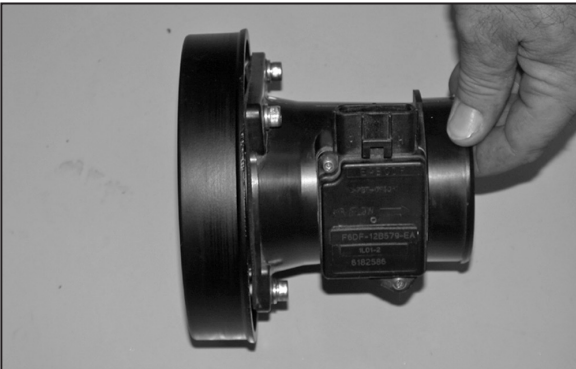

24. Attach the mass air adaptor to the mass air sensor using the gasket and provided hardware as shown.



25. Install the silicone hose (08690) onto the mass air assembly with the provided hose clamps as shown.



26. Install the K&N® intake tube onto the throttle body, then align with the saddle bracket. Then tighten all hose clamps.



27. With the provided silicone hose reconnect the crank case vent to the new intake tube as shown.

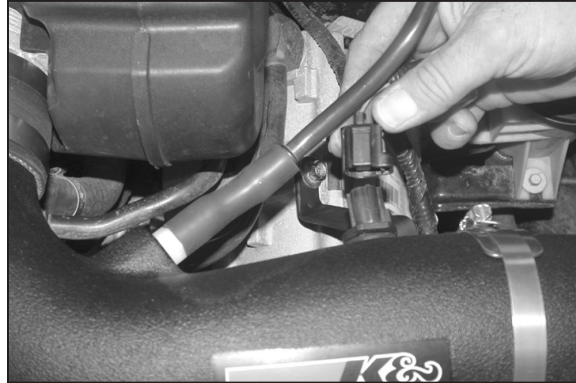

28. Reconnect the temp sensor electrical connection as shown.

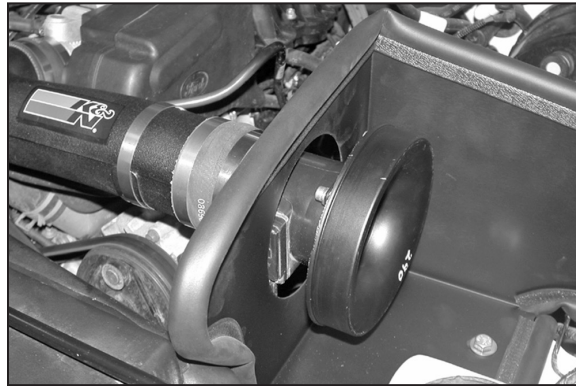

29. Install the mass air sensor assembly onto the new intake tube as shown.

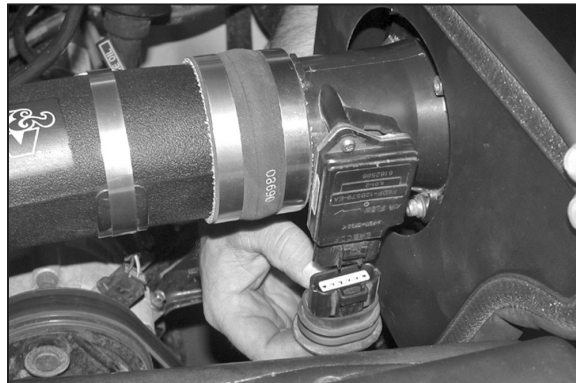

30. Reconnect the primary and secondary mass air electrical connection.

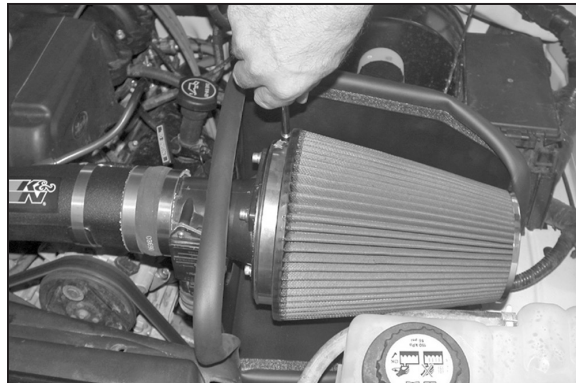

31. Install the Filtercharger onto the mass air sensor and secure it with the provided hose clamp.



32. Reconnect the vehicle's negative battery cable. Double check to make sure everything is tight and properly positioned before starting the vehicle.

33. The C.A.R.B. exemption sticker, (attached), must be visible under the hood so that an emissions inspector can see it when the vehicle is required to be tested for emissions. California requires testing every two years, other states may vary.

34. It will be necessary for all K&N® high flow intake systems to be checked periodically for realignment, clearance and tightening of all connections. Failure to follow the above instructions or proper maintenance may void warranty.

#### ROAD TESTING:

1. Start the engine with the transmission in neutral or park, and the parking brake engaged. Listen for air leaks or odd noises. For air leaks secure hoses and connections. For odd noises, find cause and repair before proceeding. This kit will function identically to the factory system except for being louder and much more responsive.

2. Test drive the vehicle. Listen for odd noises or rattles and fix as necessary.

3. If road test is fine, you can now enjoy the added power and performance from your kit.

4. K&N Engineering, Inc., requires cleaning the intake system's air filter element every 100,000 miles. When used in dusty or off-road environments, our filters will require cleaning more often. We recommend that you visually inspect your filter once every 25,000 miles to determine if the screen is still visible. When the screen is no longer visible some place on the filter element, it is time to clean it. To clean and re-oil, purchase our filter Recharger® service kit, part number 99-5050 or 99-5000 and follow the easy instructions.