



INSTALLATION INSTRUCTIONS

57-2533

FORD / MAZDA

1998-01 Ranger / B3000

V6-3.0L

NOTE: This kit was not designed to fit vehicles with a body lift.

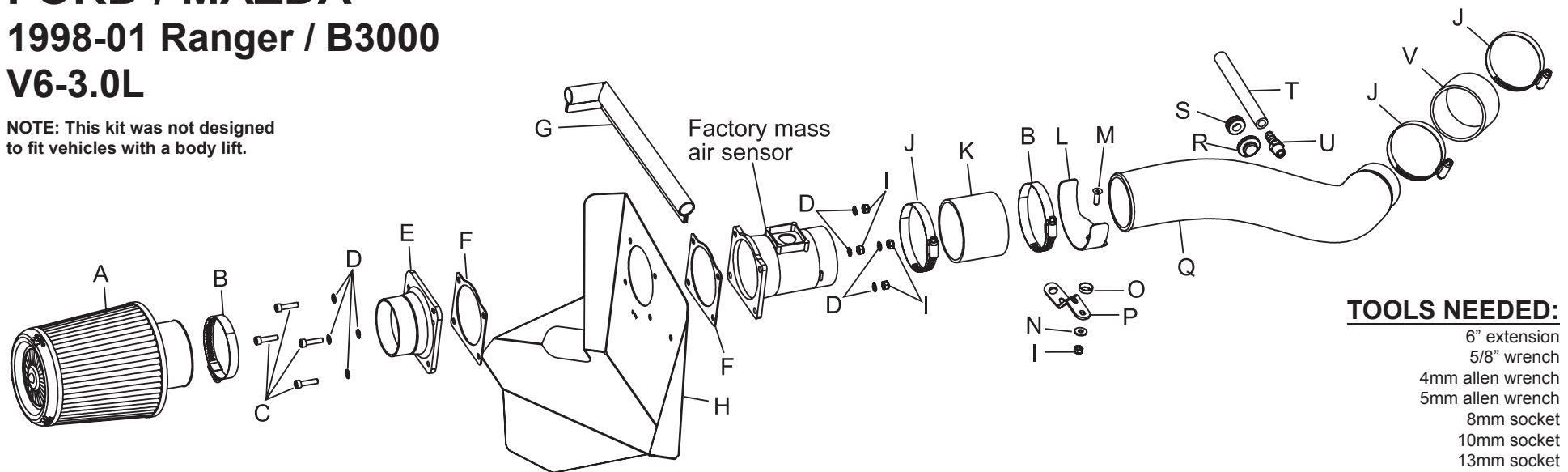

TOOLS NEEDED:

6" extension
5/8" wrench
4mm allen wrench
5mm allen wrench
8mm socket
10mm socket
13mm socket
flat blade screwdriver
ratchet

PARTS LIST:

Description	Qty.	Part #	Description	Qty.	Part #	Description	Qty.	Part #
A Air filter	1	RX-4730	I 6mm Nylock Nut	5	07553	Q Intake Tube	1	087024
B Hose Clamp, #48	2	08601	J Hose Clamp, #44	3	08577	R Rubber Plug	1	21684
C 6mm Cap Screw, 25mm L.	4	07859	K Silicone Hose, 3" ID	1	08192	S Grommet	1	08092
D 6mm Wave Washer	8	08174	L Saddle Bracket	1	078855	T 10mm Hose, 10" L.	1	08107
E Mass Air Adapter	1	088043	M 6mm Flat Head Allen Bolt	1	08376	U 3/8" Vent, 1/4" NPT	1	08047
F Gasket	2	09202	N 1/4" ID Flat Washer	1	08275	V Silicone Hose, 2-3/4" ID	1	08756
G Edge Trim, 11" L.	1	102468	O Conical Washer	1	08180			
H Heat Shield	1	07446	P "Z" Bracket	1	070993			

NOTE: FAILURE TO FOLLOW INSTALLATION INSTRUCTIONS AND NOT USING THE PROVIDED HARDWARE MAY DAMAGE THE INTAKE TUBE, THROTTLE BODY AND ENGINE.

TO START:

1. Turn off the ignition and disconnect the negative battery cable.



2. Disconnect the mass air sensor electrical connection as shown.



3. On vehicles equipped with an air temperature sensor disconnect the electrical connection as shown.



4. Disconnect and remove the crank case vent hose from the stock rubber intake tube as shown.



5. Loosen and remove the two bolts that secure the throttle linkage cover then remove the cover as shown.



6. Loosen the hose clamps at the throttle body and at the mass air sensor, then, remove the stock rubber intake tube as shown.



7. Slide a flat blade screwdriver in between the air cleaner and the air cleaner mounting tray. Pry downwards on the tray, while pulling upwards on the air cleaner assembly to release the assembly from the retaining grommets in the tray.



8. Pull firmly on the air inlet duct to release the duct from the radiator core support as shown.

NOTE: K&N Engineering, Inc., recommends that customers do not discard factory air intake.

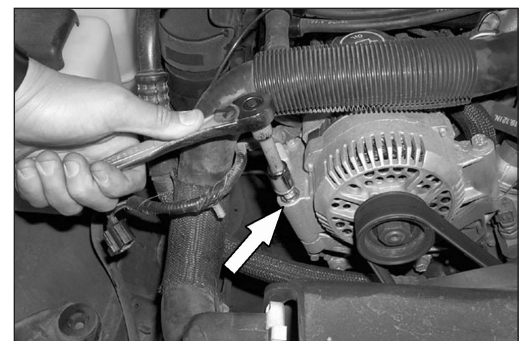

9. Loosen and remove the lower front alternator hex bolt as shown.



10. Remove the air temperature sensor from the stock rubber intake tube as shown.



11. Loosen and remove the four hex bolts that secure the mass air sensor, then remove the mass air sensor from the air cleaner as shown.

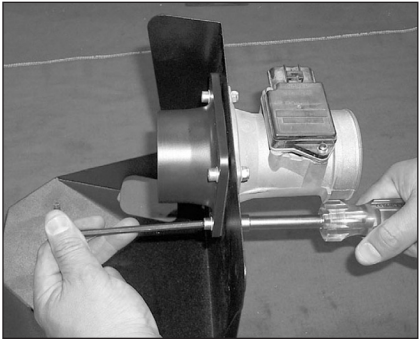

12. Assemble the mass air adapter, heat shield, gaskets and the stock mass air sensor using the provided hex bolts and wave washers as shown.



13. Install the trim seal onto the top edge of the heat shield assembly as shown

NOTE: Some trimming of the edge trim will be necessary.



14. Install the silicone hose and hose clamps onto the throttle body as shown.

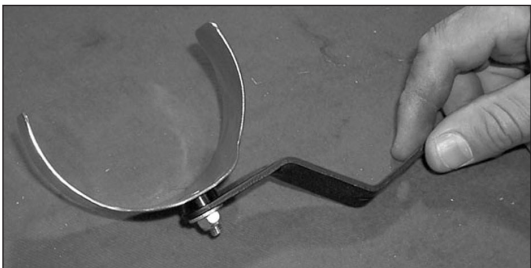

15. Assemble the saddle bracket assembly using the provided hardware as shown.

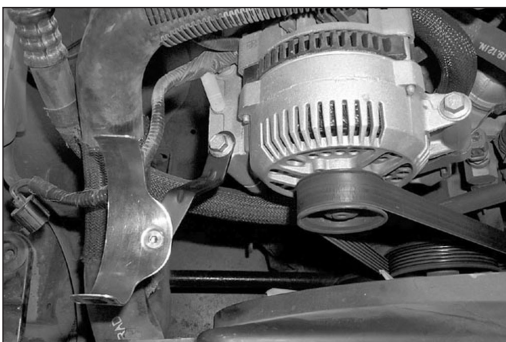

16. Using the bolt removed in step 9, secure the saddle bracket assembly to the alternator as shown. Do not tighten completely at this time.

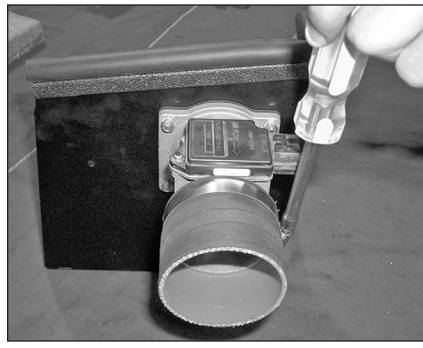

17. Install the silicone hose and the #44 hose clamp onto the mass air sensor as shown.

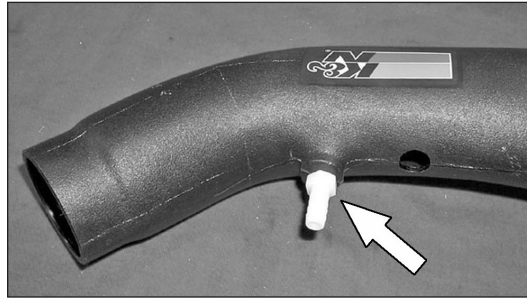

18. Install the 3/8" vent into the threaded boss on the K&N® intake tube as shown.

NOTE: Plastic NPT fittings are easy to cross thread. Install the vent fitting "hand" tight, then turn it two complete turns with a wrench.

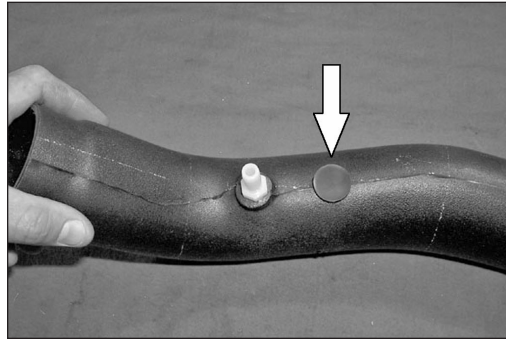

19. On vehicles not equipped with an air temperature sensor, insert the provided plug into the hole on the K&N® intake tube as shown



20. On vehicles equipped with an air temperature sensor, install the provided rubber grommet into the hole on the K&N® intake tube, then push the stock air temperature sensor into the grommet as shown. **NOTE: Take care when handling the temp sensor as it is very fragile.**

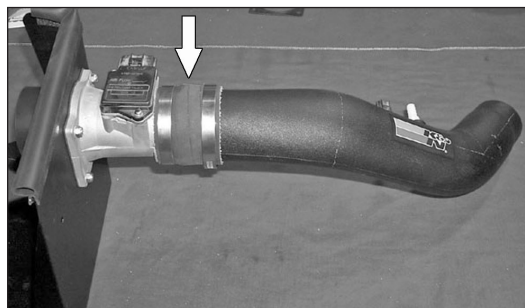

21. Install the #48 hose clamp onto the silicone hose on the mass air sensor, then slide the K&N® intake tube into the silicone hose. Do not tighten the hose clamp at this time.

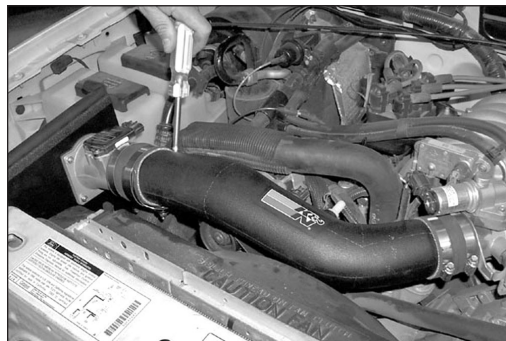

22. Install the complete assembly by sliding the intake tube into the silicone hose at the throttle body then line up the silicone hose at the mass air sensor with the saddle bracket. Secure the saddle bracket to the tube and silicone hose with the #48 hose clamp as shown.

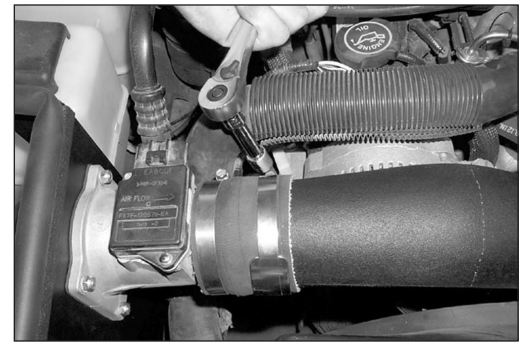

23. Double check to make sure that the saddle bracket is properly positioned, then tighten the alternator bolt as shown.

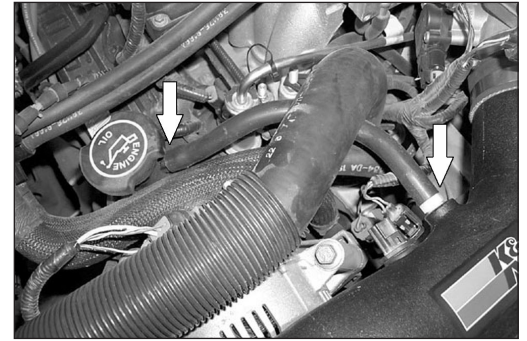

24. Replace the stock crank case hard line with the provided silicone hose and reconnect the hose to the K&N® intake tube as shown.



25. Reconnect the air temperature sensor electrical connection as shown.

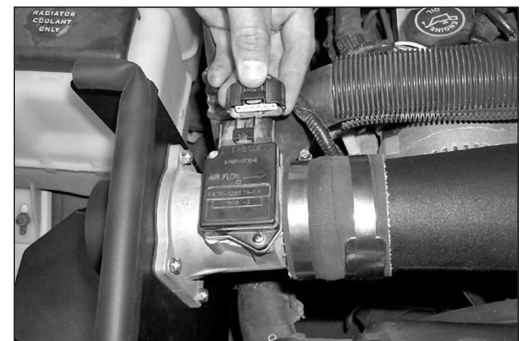

26. Reconnect the mass air sensor electrical connection as shown.



27. Install the K&N® air filter and secure with the provided hose clamp.



28. Install the stock throttle linkage cover using the factory bolts removed in step 5.



29. Reconnect the vehicle's negative battery cable. Double check to make sure everything is tight and properly positioned before starting the vehicle.

30. The C.A.R.B. exemption sticker, (attached), must be visible under the hood, so the emissions inspector can see it when the vehicle is required to be tested for emissions. California requires testing every two years, other states may vary.

31. It will be necessary for all K&N® high flow intake systems to be checked periodically for realignment, clearance and tightening of all connections. Failure to follow the above instructions or proper maintenance may void warranty.

ROAD TESTING:

1. Start the engine with the transmission in neutral or park, and the parking brake engaged. Listen for air leaks or odd noises. For air leaks secure hoses and connections. For odd noises, find cause and repair before proceeding. This kit will function identically to the factory system except for being louder and much more responsive.

2. Test drive the vehicle. Listen for odd noises or rattles and fix as necessary.

3. If road test is fine, you can now enjoy the added power and performance from your kit.

4. K&N Engineering, Inc., suggests checking the air filter element periodically for excessive dirt build-up. When the element becomes covered in dirt (or once a year), service it according to the instructions on the Recharger® service kit, part number 99-5050 or 99-5000.