



# FUEL INJECTION PERFORMANCE KIT FIPK

## INSTALLATION INSTRUCTIONS

### 57-2503

### FORD

- 1988-95 Bronco V8-5.0 / 5.8L
- 1988-92 Bronco L6-4.9L
- 1988-95 F150 L6-4.9L & V8-5.0L / 5.8L
- 1989 F150 V8-7.5L
- 1988-1995 F250 / F350 V8-5.8 / 7.5L
- 1988-91 F250 L6-4.9L
- 1988-89 F250 V8-5.0L
- 1988-89 F350 L6-4.9L

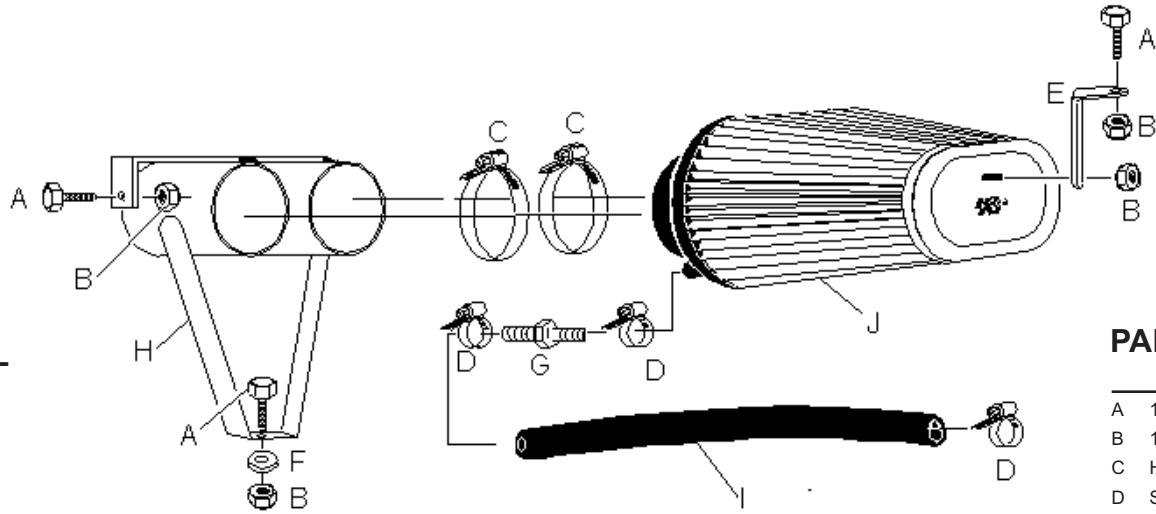

#### PARTS LIST:

Description	Qty.	P/N
A 1/4" X 5/8" hex bolt	3	08315
B 1/4" nylock nut	4	07517
C Hose clamp	2	08605
D Small hose clamp	3	08411
E "L" bracket	1	07078
F Washer	1	08160
G Vent	1	08048
H Bracket	1	07081
I Vent hose	1	08193
J Air Filter	1	RF-1012

**NOTE: FAILURE TO FOLLOW INSTALLATION INSTRUCTIONS AND NOT USING THE PROVIDED HARDWARE MAY DAMAGE THE INTAKE TUBE, THROTTLE BODY AND ENGINE.**

#### INSTALLATION

See the figure below for stock part locations.

See the exploded view for finished kit locations.

- 1) Disconnect the vehicle's negative battery cable.
- 2) Unclamp intake hoses from the airbox and remove vent hose from airbox and valve cover.
- 3) Unbolt the airbox and remove it from vehicle.
- 4) Install the "L" bracket to the end of filter, and clamp filter to adapter.
- 5) Install supplied vent hose and fitting into the filter.  
(on some vehicles you may be able to use your stock hose.)
- 6) Before you mark and drill any holes, attach the [intake hoses](#) to the filter adapter and position the complete assembly (shown in fig. 1.). Drill three 5/16" holes and secure with provided hardware (Make sure you have clearance for the hood hang). Cut and secure vent hose to valve cover fitting.
- 7) Position for best clearance and tighten all hardware.
- 8) Re-connect battery cable. Double check to make sure everything is tight and properly positioned before starting vehicle.
- 9) The C.A.R.B. exemption sticker, (attached) must be placed in a visible area under the hood, so that an emissions inspector can see it when the vehicle is required to be tested for emissions. California requires testing every two years, other states may vary.
- 10) It will be necessary for all FIPK's to be checked periodically for realignment, clearance and tightening of all connections. Failure to follow the above instructions or proper maintenance may void warranty.

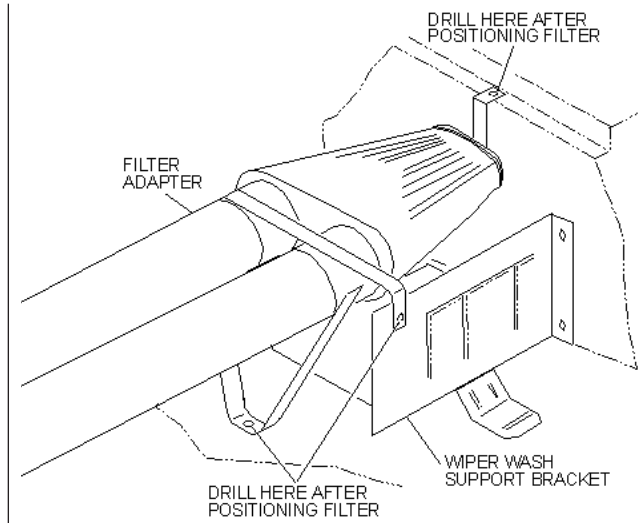

fig. 1

#### ROAD TESTING

Start the engine with the transmission in neutral or park, and the emergency brake on. Listen for any air leaks or odd noises. If there are air leaks, make sure the hose connections are secure. If there are any odd noises, check for the cause and repair before proceeding. The K&N Filtercharger® Injection Performance Kit will function identically to the factory air filter with the exception of being slightly louder than stock and much more responsive. If all preliminary checks are okay, then a road test is necessary. Listen carefully for rattling or other odd noises and fix as necessary. If the road test is fine, you can enjoy driving as normal with the added response and power. We suggest that the Filtercharger® element be checked periodically for dirt. This is now very easy due to the open element configuration. If the filter material is overly dirty, service it according to the instructions that are in the Recharger service kit part number 99-5050 or 99-5000.

### Ford Pickups F-150,250,350, & Bronco

This is the hose configuration for the L6-4.9L. This configuration may vary with other engines but will have no effect on the kit installation.

