



INSTALLATION INSTRUCTIONS

57-1550
CHRYSLER
2006-10 PT Cruiser
L4-2.4L

TOOLS NEEDED:

- Flat Blade Screwdriver
- Ratchet
- Extension
- 10mm Socket
- 9/16" Socket
- 10mm Wrench
- 4mm Allen Wrench

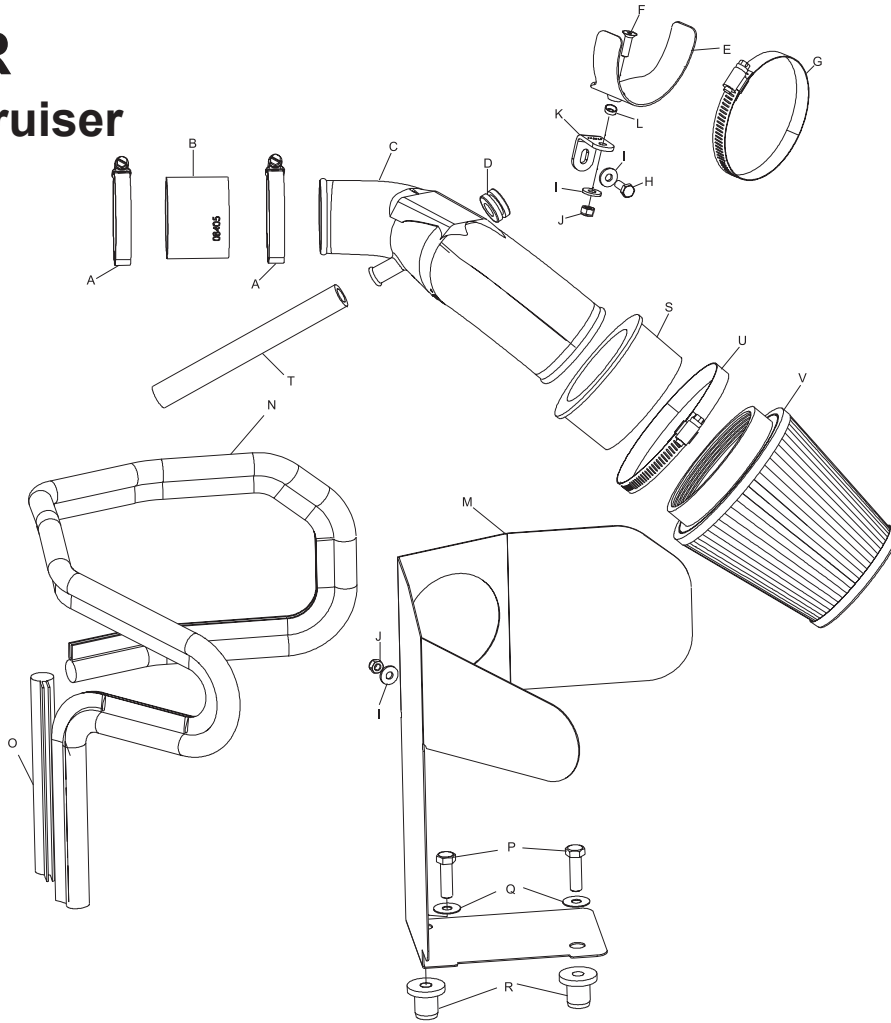

PARTS LIST:

Description	Qty.	Part #
A Hose Clamp; #40	2	08554
B Hose;2-3/8"ID X 2"1,silicone	1	08405
C Intake Tube	1	087196
D Grommet; 1"OD, 1/2" Thk.	1	08064
E Bracket: Saddle S/S	1	078855
F Bolt;6mm-1.00x 20mm F/H/A, SS	1	08376
G Hose Clamp: # 48	1	08601
H Bolt;6mm-1.00x 16mm Hexhead	1	07703
I Washer;1/4"ID X 5/8"OD, Flat	3	08275
J Nut; 6mm Nylock	2	07553
K Bracket; Small "L"	1	070066
L Cup Washer	1	08180
M Heat Shield	1	07323
N Edge Trim 50"	1	102481
O Edge Trim 9"	1	102465
P Bolt;3/8"-16x1-1-1/4"1 SS Hex Head	2	07779
Q Washer; 3/8" SS, Flat	2	08134
R Inserted Nut ;3/8-16x3/4"x15/16"	2	08163
S Filter Adapter	1	21561
T Hose;1/2"ID X 7"1, Black Silicone	1	08159
U Hose Clamp: # 64	1	08648
V Air Filter	1	RP-4660

NOTE: FAILURE TO FOLLOW INSTALLATION INSTRUCTIONS AND NOT USING THE PROVIDED HARDWARE MAY DAMAGE THE INTAKE TUBE, THROTTLE BODY AND ENGINE.

TO START:

1. Turn off the ignition and disconnect the negative battery cable.
NOTE: Disconnecting the negative battery cable erases pre-programmed electronic memories. Write down all memory settings before disconnecting the negative battery cable. Some radios will require an anti-theft code to be entered after the battery is reconnected. The anti-theft code is typically supplied with your owner's manual. In the event your vehicles' anti-theft code cannot be recovered, contact an authorized dealership to obtain your vehicles anti-theft code.



2. Disconnect the air temp. electrical sensor as shown.



3. Loosen the hose clamp, which secures the intake tube to the throttle body.

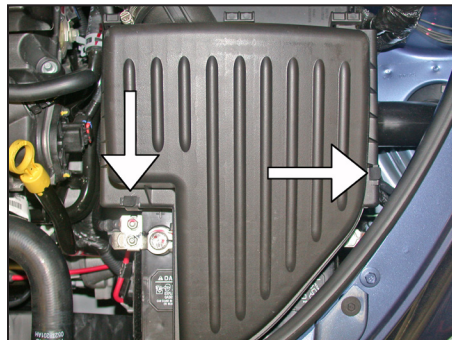

4. Unlatch the two airbox lid retaining clips and remove the airbox lid and intake tube from the vehicle.

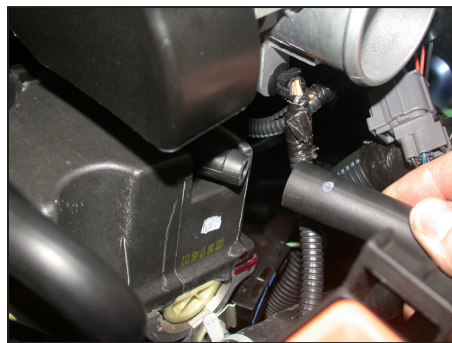

5. Disconnect the crankcase vent hose from the valve cover as shown.



6. Pull up firmly on the airbox base to dislodge it from the retaining grommets and then remove the airbox from the vehicle.
NOTE: K&N Engineering, Inc., recommends that customers do not discard factory air intake.



7. Remove the two airbox retaining grommets from mounting tray as shown.

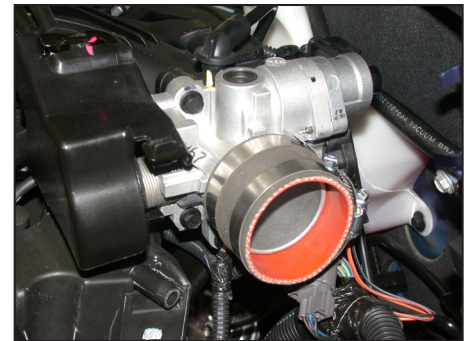

8. Install the silicone hose (08405) onto the throttle body and secure with the provided hose clamp as shown.



9. Install the long edge trim onto the heat shield as shown.
NOTE: Some trimming of the edge trim may be necessary.



10. Install the short edge trim onto the heat shield as shown.

NOTE: Some trimming of the edge trim may be necessary.



11. Using the provided hardware, install the small "L" bracket (070066) onto the saddle clamp as shown.



12. Install the saddle bracket assembly onto the heat shield as shown using the provided hardware.

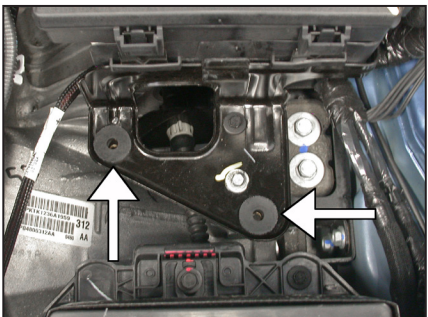

13. Install the two provided inserted nuts into the airbox mounting plate as shown.

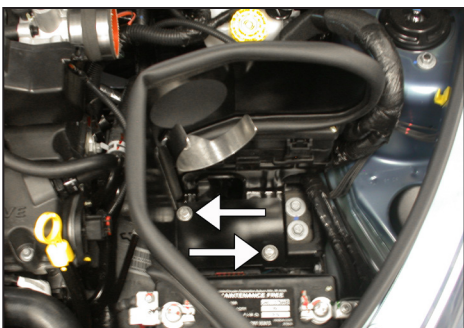

14. Install the heat shield onto the inserted nuts installed in step #13 and secure with the provided bolts and washers.



15. Install the provided grommet into the K&N® intake tube as shown.



16. Carefully remove the air temperature sensor from the stock intake tube as shown.

NOTE: Use care when removing the sensor as it is very fragile.



17. Install the air temperature sensor into the K&N® intake tube as shown.



18. Feed the K&N® intake tube through the heat shield and saddle clamp and then into the silicone hose at the throttle body. Do not completely tighten at this time.

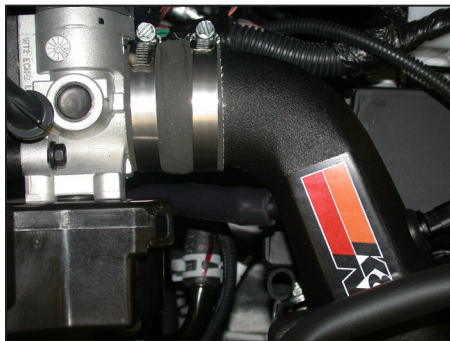

19. Connect the provided crankcase vent hose onto the valve cover and then the K&N® intake tube as shown.



20. Reconnect the air temperature electrical connection.



21. Install the provided filter adapter into the K&N® air filter as shown.

NOTE: Do not tighten hose clamp at this time.



22. Install the K&N® filter assembly onto the K&N® intake tube, adjust the intake kit for the best fit and tighten all of the hose clamps.

NOTE: Drycharger® air filter wrap; part # RP-4660DK is available to purchase separately.

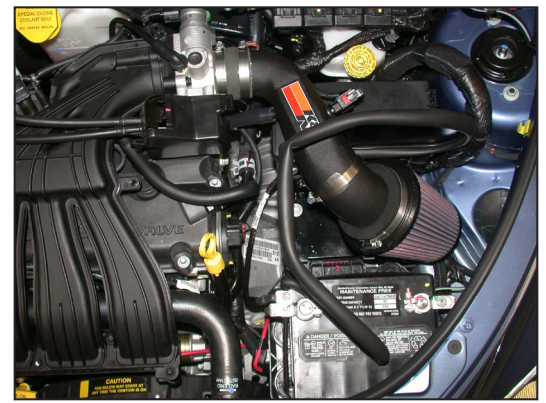

23. Reconnect the vehicle's negative battery cable. Double check to make sure everything is tight and properly positioned before starting the vehicle.

24. The C.A.R.B. exemption sticker, (attached), must be visible under the hood so that an emissions inspector can see it when the vehicle is required to be tested for emissions. California requires testing every two years, other states may vary.

25. It will be necessary for all K&N® high flow intake systems to be checked periodically for realignment, clearance and tightening of all connections. Failure to follow the above instructions or proper maintenance may void warranty.

ROAD TESTING:

1. Start the engine with the transmission in neutral or park. Listen for air leaks or odd noises. For air leaks secure hoses and connections. For odd noises, find cause and repair before proceeding. This kit will function identically to the factory system except for being louder and much more responsive.

2. Test drive the vehicle. Listen for odd noises or rattles and fix as necessary.

3. If road test is fine, you can now enjoy the added power and performance from your kit.

4. K&N Engineering, Inc., suggests checking the air filter element periodically for excessive dirt build-up. When the element becomes covered in dirt (or once a year), service it according to the instructions on the Recharger® service kit, part number 99-5050 or 99-5000.