



INSTALLATION INSTRUCTIONS

57-1522

CHRYSLER / DODGE

2000-03 Intrepid R/T

2004 Intrepid SXT

2000-04 300M

V6-3.5L

TOOLS NEEDED:

- 1/4" Drive Ratchet
- 3/8" Drive Ratchet
- Long Extension
- 10mm Socket
- 13mm Socket
- 15mm Socket
- 1/4" Socket
- Side Cutters
- Flathead Screwdriver
- Lubricant

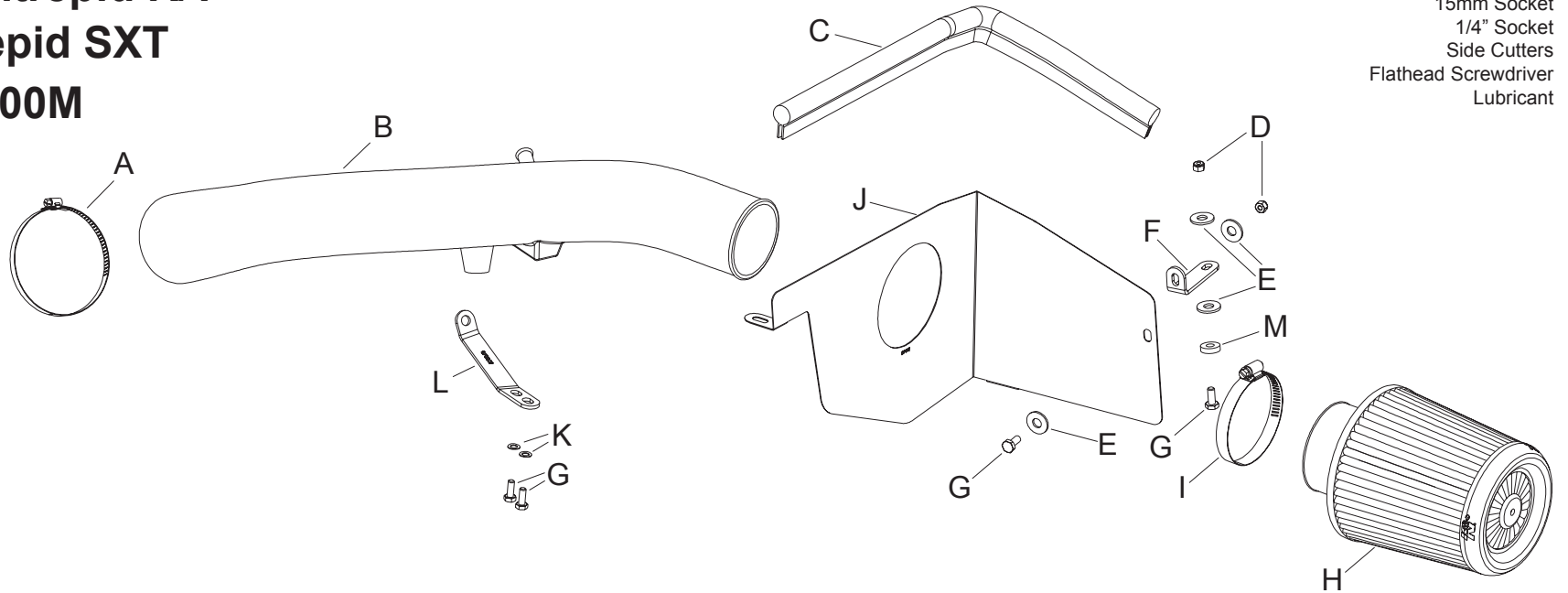

PARTS LIST:

Description	Qty.	Part #	Description	Qty.	Part #	Description	Qty.	Part #
A Hose Clamp #56 MIDI	1	08465	F Bracket; L-Bend	1	07805	K Washer; 6mm Wave	2	08174
B Intake Tube #12	1	087023	G Bolt; M6-1 x 16mm	4	07703	L Bracket; J-Bend	1	070007
C Edge Trim 23"L	1	102495	H Air Filter	1	RX-4730	M Spacer; White	1	06502
D Nut; 6mm Nylock Hex-Head	2	07553	J Heat Shield	1	07442			
E Washer; 1/4"ID X 5/8"OD	4	08275						

NOTE: FAILURE TO FOLLOW INSTALLATION INSTRUCTIONS AND NOT USING THE PROVIDED HARDWARE MAY DAMAGE THE INTAKE TUBE, THROTTLE BODY AND ENGINE.

TO START:



1. Turn off the ignition and disconnect the negative battery cable.
NOTE: Disconnecting the negative battery cable erases pre-programmed electronic memories. Write down all memory settings before disconnecting the negative battery cable. Some radios will require an anti-theft code to be entered after the battery is reconnected. The anti-theft code is typically supplied with your owner's manual. In the event your vehicles' anti-theft code cannot be recovered, contact an authorized dealership to obtain your vehicles anti-theft code.



2. Loosen the Hose Clamps, using an 8mm socket.



3. Lubricate Grommet.



4. By pulling upward, remove Center Intake Tract Assembly off the grommet.



5. Lubricate Grommet and remove Front Airbox in an upward direction.



6. Remove Vent Hose from Rear Intake Tract Assembly. (DO NOT remove from engine.)

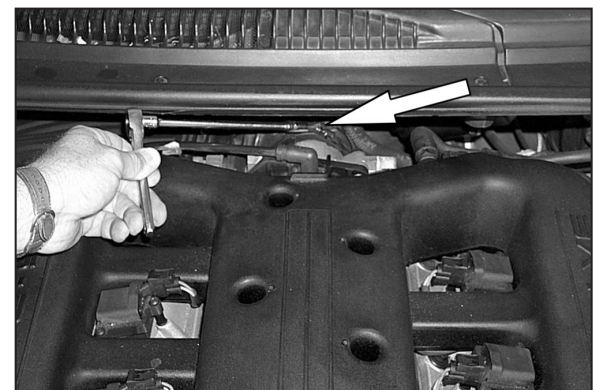

7. Loosen Hose Clamp at the Throttle Body using a 1/4" socket.



8. Lubricate Grommet and remove rear Intake tract Assembly.



9. Remove Metal Band by cutting with Sidecutters.



10. Replace Metal Band with #56 Hose Clamp supplied, as shown.

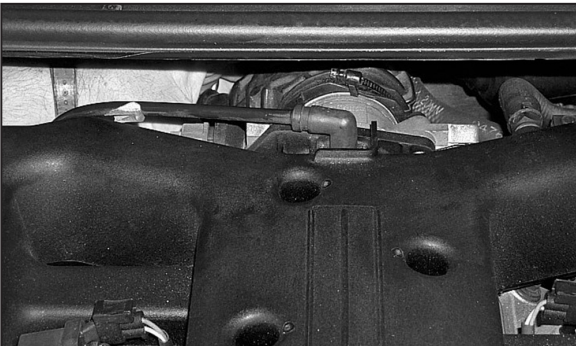

11. Reinstall Throttle Body Hose to throttle body and tighten Hose Clamp.

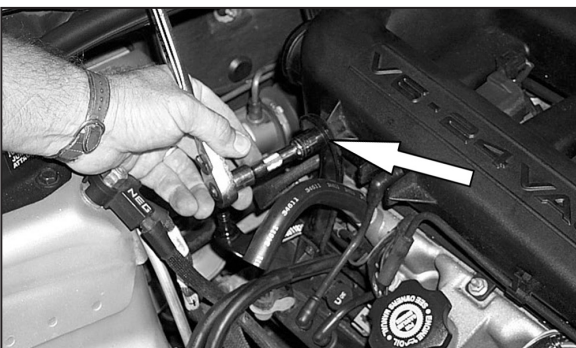

12. Using a 3/8" Drive Ratchet and a 13mm socket, remove stock Bolt, as shown. (Bolt will be reused.)

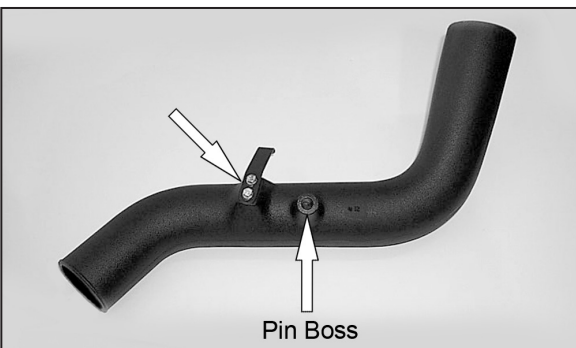

13. Clean the inside of the K&N® Intake Tube and assemble Bracket to Intake Tube using (2) Bolts and (2) Wave Washers. (Hand tighten only.)

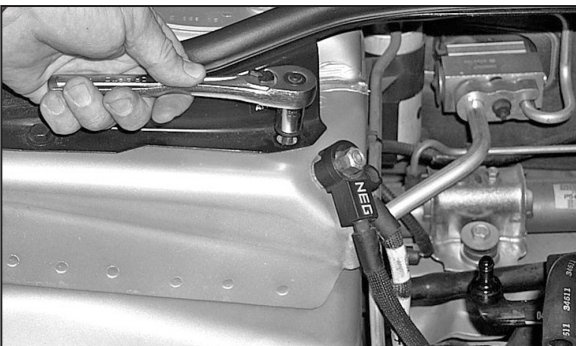

14. Remove Cowl Bolt located above the Negative Battery Cable, using a 3/8" Drive Ratchet and a 13mm socket. (Bolt will be reused.)

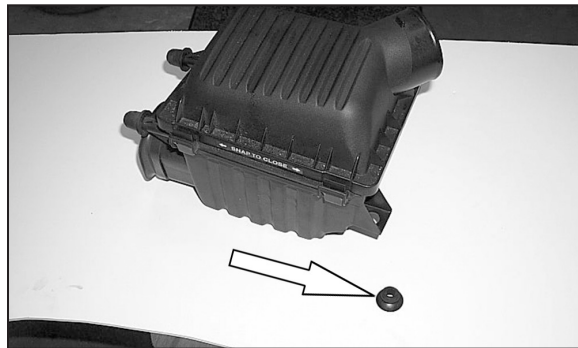

15. Remove Grommet from Airbox, as shown.



16. Install Edge Trim Seal, as shown. (Remove any excess Edge Trim using Sidecutters.)



17. Install the Stock Grommet from #15, onto the stock Locating Pin position, as shown.

NOTE: On some models, a black, plastic radiator-core cover is used. If this is on your vehicle, the white, nylon spacer (P/N 06502) must be used. Step #18 and #19 will demonstrate this installation. If your vehicle does not have this cover, continue to step #20.

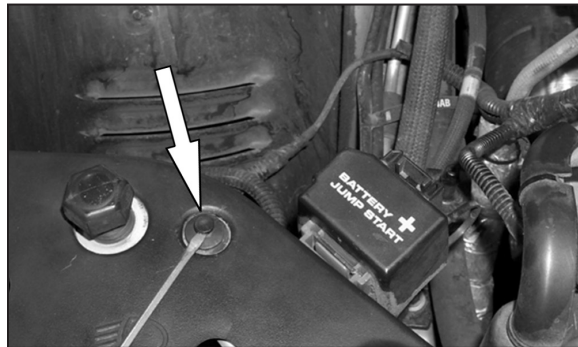

18. Using a Flathead Screwdriver, remove the stock plastic socket-head capscrew.

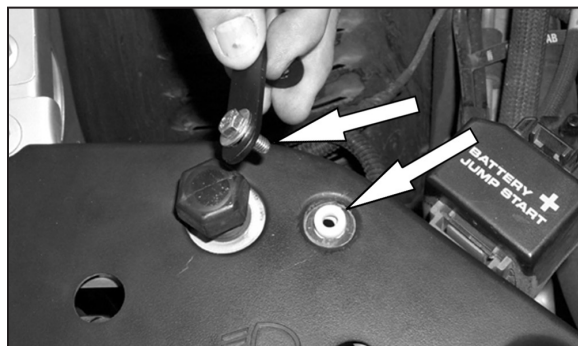

19. Place the white, nylon Spacer, as shown, and install the Heat Shield Bracket on hole located behind the passenger-side headlight, using a 6mm Bolt, (2) Flat Washers, and a Lock Nut. (Hand tighten Only. Adjustments will be made later.)



20. Install small Heat Shield Bracket on hole located behind the passenger-side headlight, using a 6mm Bolt, (2) Flat Washers, and a Lock Nut. (Hand tighten Only. Adjustments will be made later.)

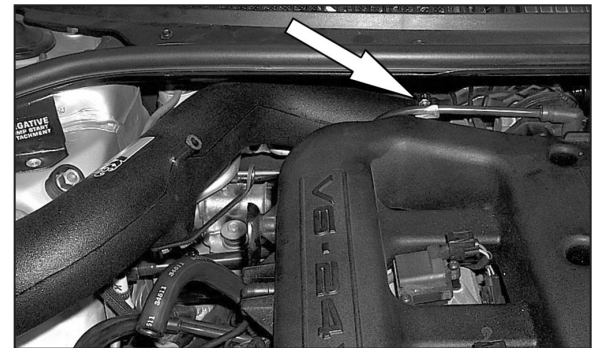

21. Install Intake Tube into Throttle Body Hose, as shown.



22. Place Intake Tube through hole of Heat Shield, and insert 1" tapered, Pin Boss (see #13) over Locating Pin, as shown.

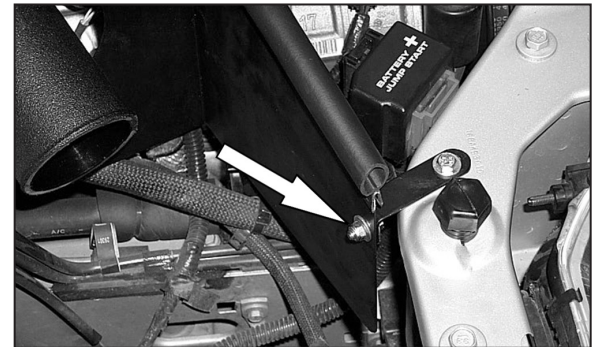

23. Attach Heat Shield to Bracket, using a Bolt, Washer and Nylock Nut provided.



24. Hand tighten Cowl Bolt back into the stock location.

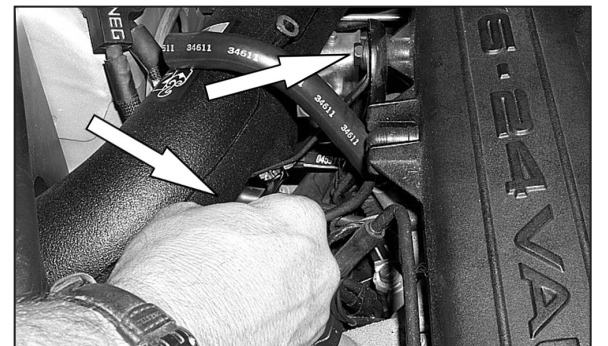

25. Tighten all bolts on brackets, as shown.



26. Tighten Heat Shield Bracket Bolts and Cowl Bolt. Install Vent Hose to Intake Tube, as shown.



27. Install K&N® Filter and tighten Hose Clamp.
NOTE: Drycharger® air filter wrap; part # RX-4730DK is available to purchase

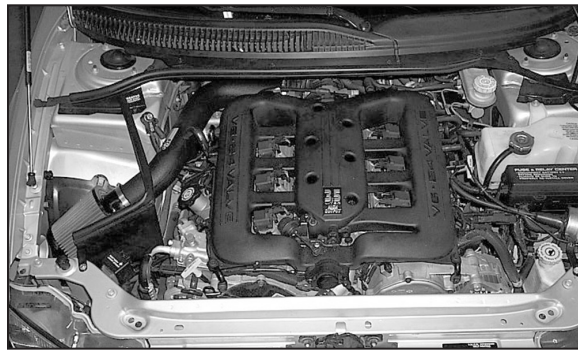

28. Reconnect the vehicle's negative battery cable. Double check to make sure everything is tight and properly positioned before starting the vehicle.

29. The C.A.R.B. exemption sticker, (attached), must be visible under the hood so that an emissions inspector can see it when the vehicle is required to be tested for emissions. California requires testing every two years, other states may vary.

30. It will be necessary for all K&N® high flow intake systems to be checked periodically for realignment, clearance and tightening of all connections. Failure to follow the above instructions or proper maintenance may void warranty.

ROAD TESTING:

1. Start the engine with the transmission in neutral or park, and the parking brake engaged. Listen for air leaks or odd noises. For air leaks secure hoses and connections. For odd noises, find cause and repair before proceeding. This kit will function identically to the factory system except for being louder and much more responsive.

2. Test drive the vehicle. Listen for odd noises or rattles and fix as necessary.

3. If road test is fine, you can now enjoy the added power and performance from your kit.

4. K&N Engineering, Inc., requires cleaning the intake system's air filter element every 100,000 miles. When used in dusty or off-road environments, our filters will require cleaning more often. We recommend that you visually inspect your filter once every 25,000 miles to determine if the screen is still visible. When the screen is no longer visible some place on the filter element, it is time to clean it. To clean and re-oil, purchase our filter Recharger® service kit, part number 99-5050 or 99-5000 and follow the easy instructions.