



# INSTALLATION INSTRUCTIONS

57-1520

JEEP

1993-98 Grand Cherokee

L6-4.0L

NOTE: This kit was not designed to fit vehicles with a body lift.

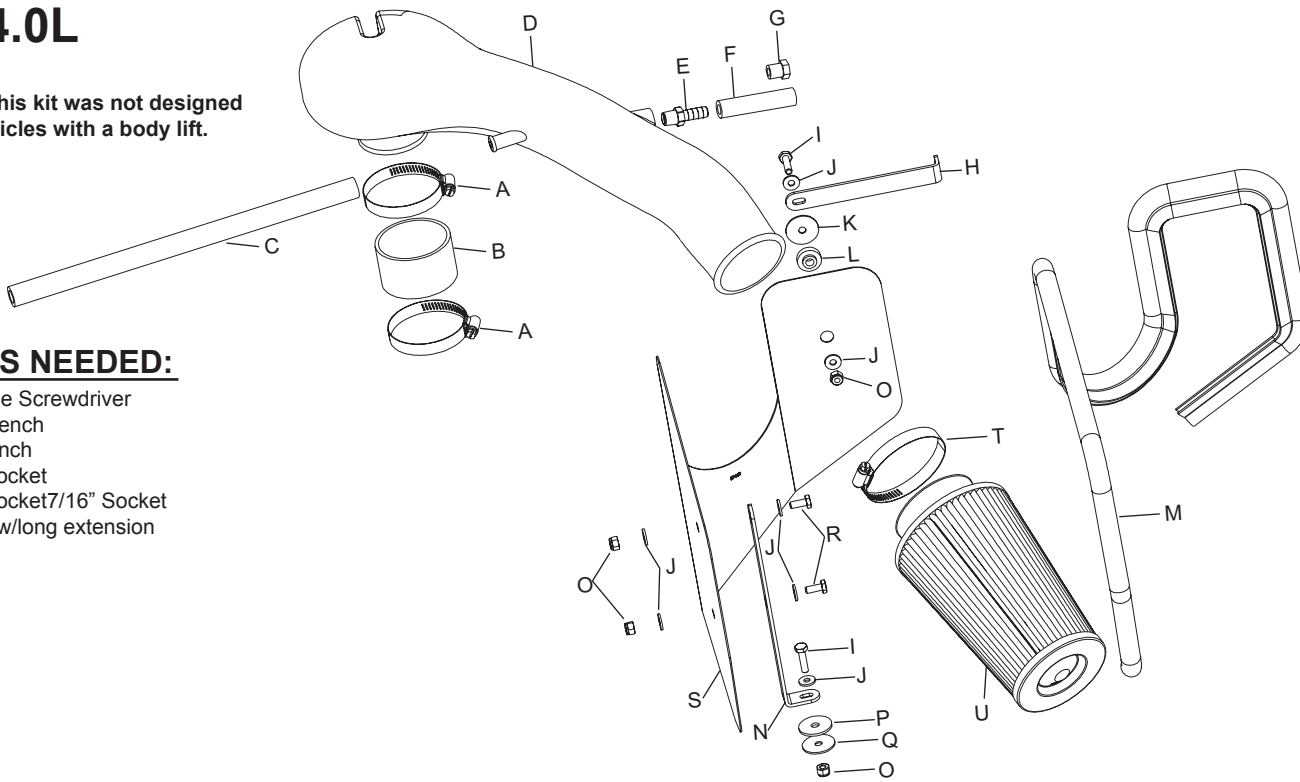

**TOOLS NEEDED:**

- Flat Blade Screwdriver
- 7/16" Wrench
- 5/8" Wrench
- 10mm Socket
- 13mm Socket/7/16" Socket
- Ratchet w/long extension

**PARTS LIST:**

Description	Qty.	Part #
A Hose clamp #40	2	08554
B Hose; 2.63"ID x 1.75"L	1	08108
C Hose 1/2" x 14"L	1	08402
D Intake tube	1	087041
E Vent strt., 3/8" x 1/4npt	1	08047
F Vent hose	1	08462
G Plug, 1/4npt, plastic, black	1	08032
H Bracket small "L"	1	070026
I Bolt 1/4-20 x 1"L hexhead	2	08314
J Washer, 1/4	7	08275
K Washer, fender 1"od x 2"ID	1	08160
L Step bushing, rubber	1	21694
M Edge trim, 50"L	1	102481
N Bracket, large "L"	1	08030
O Nylock nut	4	07517
P Rubber washer	1	21708
Q Fender washer	1	08151
R Bolt, 1/4-20 x 5/8	2	08315
S Heat shield	1	07459
T Hose clamp #48	1	08601
U Air Filter	1	RC-4690

**NOTE: FAILURE TO FOLLOW INSTALLATION INSTRUCTIONS AND NOT USING THE PROVIDED HARDWARE MAY DAMAGE THE INTAKE TUBE, THROTTLE BODY AND ENGINE.**

**TO START:**

1. Turn off the ignition and disconnect the negative battery cable.  
**NOTE: Disconnecting the negative battery cable erases pre-programmed electronic memories. Write down all memory settings before disconnecting the negative battery cable. Some radios will require an anti-theft code to be entered after the battery is reconnected. The anti-theft code is typically supplied with your owner's manual. In the event your vehicles' anti-theft code cannot be recovered, contact an authorized dealership to obtain your vehicles anti-theft code.**



2. Remove the crankcase vent line from the valve cover.



3. Remove the EVAP canister vent line from the air intake tube.



4. Loosen the hose clamp at the throttle body and unclamp the air box lid then remove the upper intake assembly as shown.

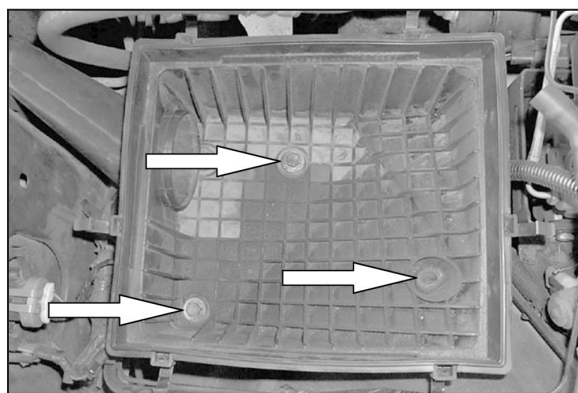

5. Loosen and remove the three bolts that secure the lower air cleaner assembly.



6. Remove the lower air cleaner assembly and fresh air intake tube.  
**NOTE: K&N Engineering, Inc., recommends that customers do not discard factory air intake.**



7. Install the trim seal onto the heat shield and trim if necessary.



8. Using the provided hardware, secure the large "L" bracket to the heat shield as shown.



9. Install the rubber step grommet onto the heat shield as shown.



10. Install small "L" bracket onto the heat shield as shown.

**NOTE: Make sure to install large washer behind "L" bracket.**

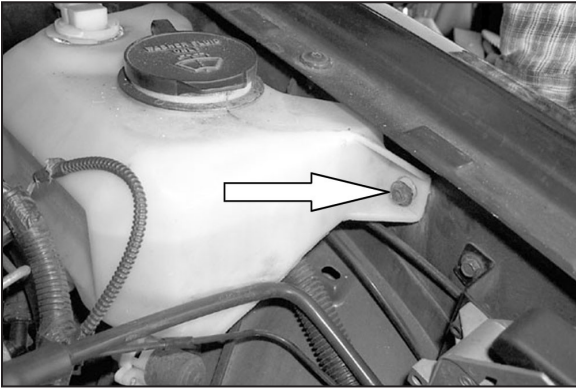

11. Remove the bolt that secures the water bottle onto the inner fender well.



12. Install heat shield assembly into vehicle as shown. Using the hardware provided, secure large "L" bracket onto vehicle inner wheel well.



13. Using the bolt that was removed in step 11, secure the small "L" bracket onto the inner wheel well.



14. Install the silicone hose and the hose clamps onto the throttle body as shown.



15. Install the K&N® intake tube onto the throttle body then tighten the hose clamp.



16. Install the provided silicone hose onto the crankcase vent on the valve cover, then install the other end onto the K&N® intake tube.



17. Install the 1/4 x 3/8" vent fitting onto the K&N® intake tube as shown.

**NOTE: Some earlier models may not be equipped with an EVAP canister, use the 1/4 plug provided and install onto the K&N® intake tube.**

**NOTE: Plastic NPT fittings are easy to cross thread. Install the vent fitting "hand" tight, then turn it two complete turns with a wrench**



18. Remove the stock rubber hose from the EVAP canister vent line as shown.

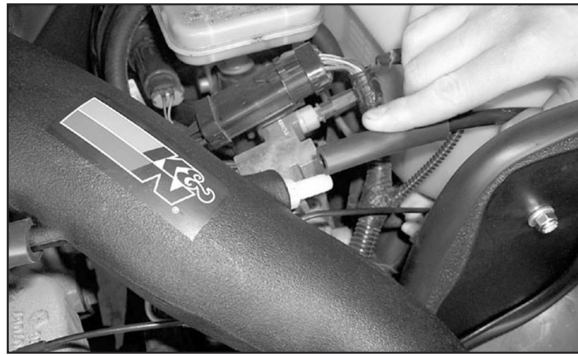

19. Install the new silicone hose onto the EVAP canister vent line and install the other end onto the K&N® intake tube as shown.



20. Install the K&N Filtercharger onto the K&N intake tube, then adjust the intake tube for best fit then tighten all hardware.

**NOTE: Drycharger® air filter wrap; part # RC-4690DK is available to purchase separately.**



21. Reconnect the vehicle's negative battery cable. Double check to make sure everything is tight and properly positioned before starting the vehicle.

22. The C.A.R.B. exemption sticker, (attached), must be visible under the hood so that an emissions inspector can see it when the vehicle is required to be tested for emissions. California requires testing every two years, other states may vary.

23. It will be necessary for all K&N® high flow intake systems to be checked periodically for realignment, clearance and tightening of all connections. Failure to follow the above instructions or proper maintenance may void warranty.

#### ROAD TESTING:

1. Start the engine with the transmission in neutral or park, and the parking brake engaged. Listen for air leaks or odd noises. For air leaks secure hoses and connections. For odd noises, find cause and repair before proceeding. This kit will function identically to the factory system except for being louder and much more responsive.

2. Test drive the vehicle. Listen for odd noises or rattles and fix as necessary.

3. If road test is fine, you can now enjoy the added power and performance from your kit.

4. K&N Engineering, Inc., requires cleaning the intake system's air filter element every 100,000 miles. When used in dusty or off-road environments, our filters will require cleaning more often. We recommend that you visually inspect your filter once every 25,000 miles to determine if the screen is still visible. When the screen is no longer visible some place on the filter element, it is time to clean it. To clean and re-oil, purchase our filter Recharger® service kit, part number 99-5050 or 99-5000 and follow the easy instructions.