



INSTALLATION INSTRUCTIONS

57-1513-1

JEEP

1999-04 Grand Cherokee

V8-4.7L

NOTE: This kit was not designed to fit vehicles with a body lift.

TOOLS NEEDED:

- Flat blade screwdriver
- Ratchet
- 7/16" socket
- 10mm deep socket
- 10mm wrench
- 13mm wrench
- 7/16" wrench

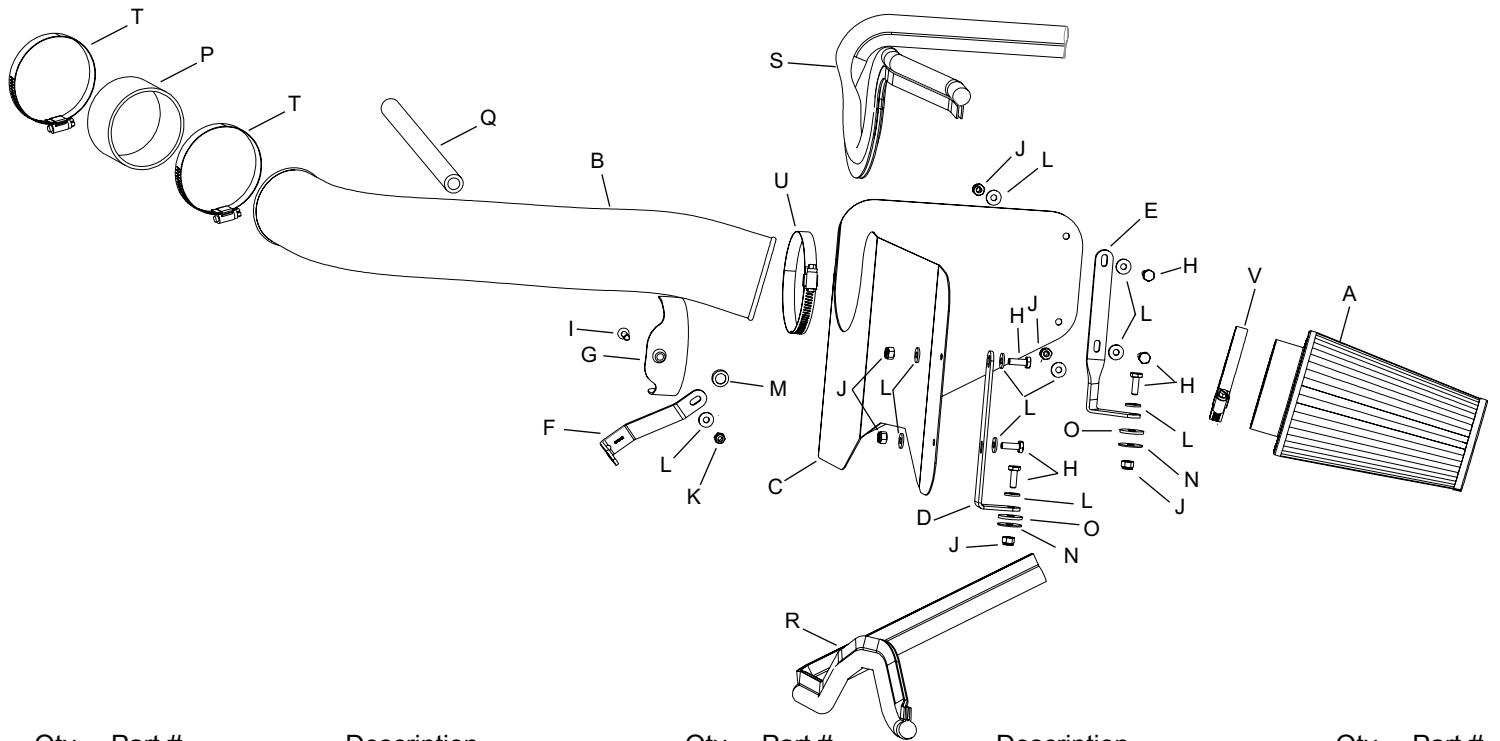

PARTS LIST:

Description	Qty.	Part #	Description	Qty.	Part #	Description	Qty.	Part #
A Filtercharger element	1	RF-1045	I 6mm-1.00 x 20mm f/h/a	1	08376	Q Vent hose	1	08402
B Intake tube	1	08777	J 1/4-20 nylock nut	6	07517	R Trim seal 26"L	1	102488
C Heat shield	1	07423	K 6mm nylock nut	1	07553	S Trim seal 30"L	1	102489
D "L" bracket	1	070902	L Flat washer	11	08275	T Hose clamp #52	2	08610
E "L" twist bracket	1	070912	M Conical washer	1	08180	U Hose clamp #56	1	08620
F Angled "L" bracket	1	070922	N Fender washer	2	08160	V Hose clamp #60	1	08624
G Saddle	1	078855	O Rubber washer	2	21685			
H 1/4-20 hexhead bolt	6	08386	P Silicone hose	1	08690			

NOTE: FAILURE TO FOLLOW INSTALLATION INSTRUCTIONS AND NOT USING THE PROVIDED HARDWARE MAY DAMAGE THE INTAKE TUBE, THROTTLE BODY AND ENGINE.

TO START:

1. Turn off the ignition and disconnect the negative battery cable.
NOTE: Disconnecting the negative battery cable erases pre-programmed electronic memories. Write down all memory settings before disconnecting the negative battery cable. Some radios will require an anti-theft code to be entered after the battery is reconnected. The anti-theft code is typically supplied with your owner's manual. In the event your vehicles' anti-theft code cannot be recovered, contact an authorized dealership to obtain your vehicles anti-theft code.



2. Detach the crankcase vent hose from the stock intake tube.



3. Loosen the hose clamp on the intake hose at the intake tube.



4. Release the 4 over center clips that retain the airbox top to airbox base.

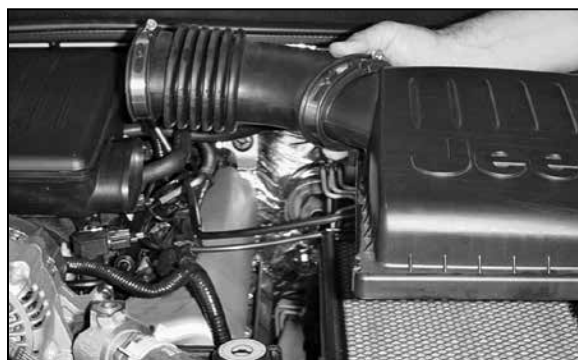

5. Detach the intake hose from the intake tube and remove the entire upper airbox assembly.

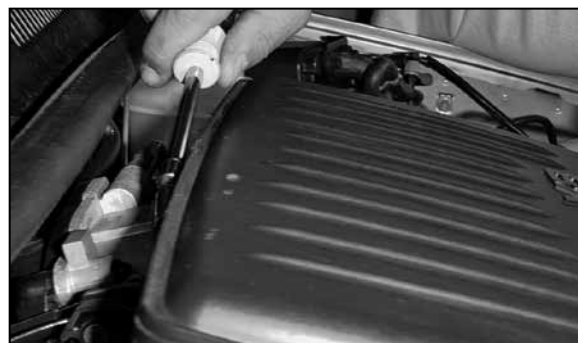

6. Loosen the hose clamp on the intake tube at the throttle body.



7. Loosen and remove the 2 bolts that retain the intake tube to the intake manifold.



8. Pull firmly upward and remove the intake tube assembly.



9. Detach the OE crankcase vent hose from the "T" fitting.

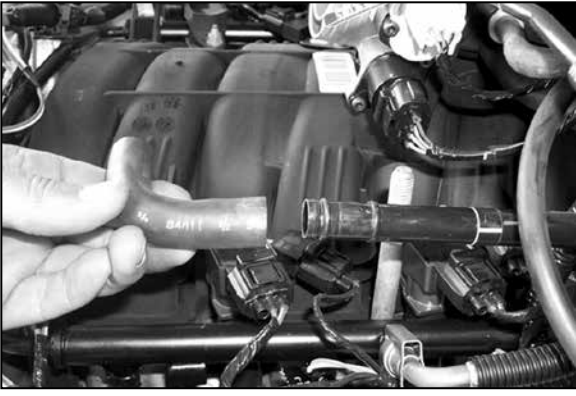

9a. On 03 models, detach the 90 degree hose from crankcase vent as shown.

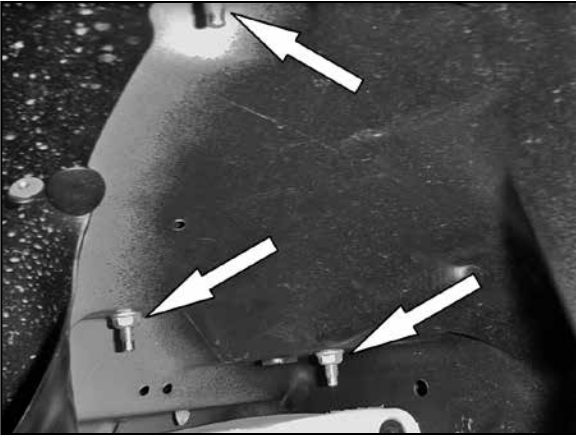

10. Loosen and remove the 3 nuts that retain the airbox base to the inner fender apron.

Note: These are accessed from the underside of the fender.



11. Detach the air inlet duct from the airbox base and remove the airbox base.



12. Release the clip that retains the air inlet duct to the radiator core support and remove the air inlet duct.

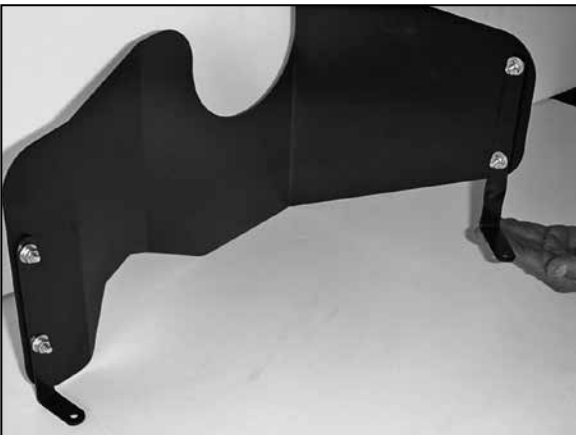

13. Attach the "L" bracket and the twisted "L" bracket to the heat shield using the hardware provided.



14. Install the trim seal onto the heat shield as shown.

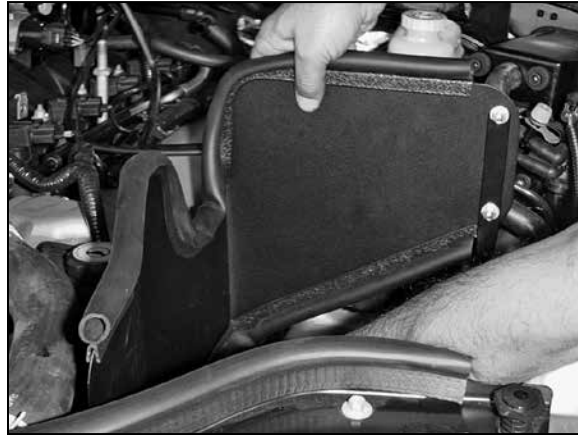

15. Install the heat shield assembly.

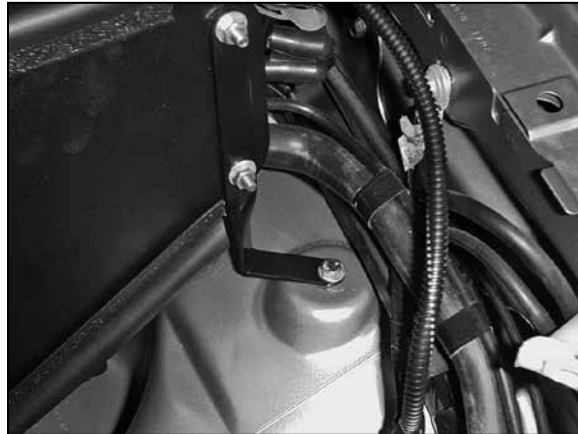

16. Attach the "L" twist bracket to the existing airbox mounting point on the inner fender apron using the hardware provided.

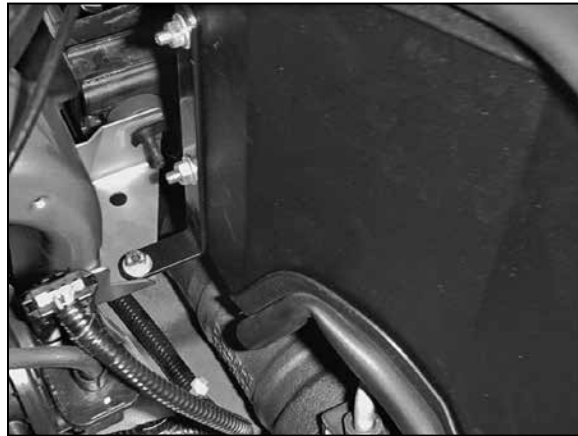

17. Attach the "L" bracket to the radiator mounting bracket using the hardware provided.



18. Assemble the saddle and angled "L" bracket using the hardware provided.

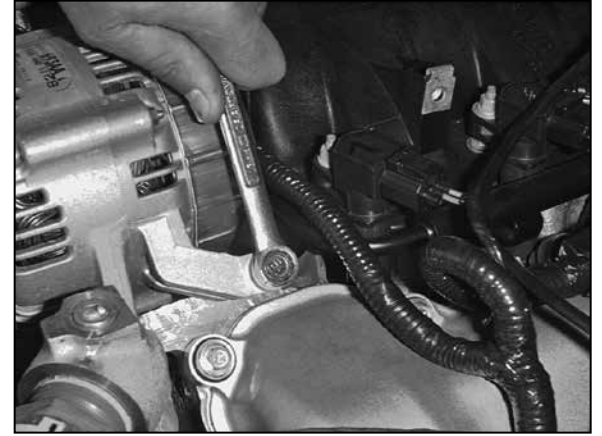

19. Loosen and remove the alternator retaining bolt.



20. Attach the saddle bracket assembly to the alternator using the bolt removed in the previous step.

Note: Do not tighten completely at this time.



21. Attach the silicone hose to the throttle body using a hose clamp provided.



22. Install the K&N® intake tube.

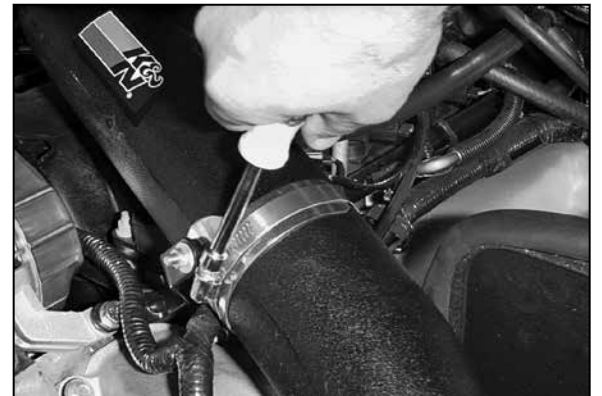

23. Secure the intake tube to the saddle bracket using the hose clamp provided.



24. Tighten the hose clamp on the silicone hose at the intake tube.

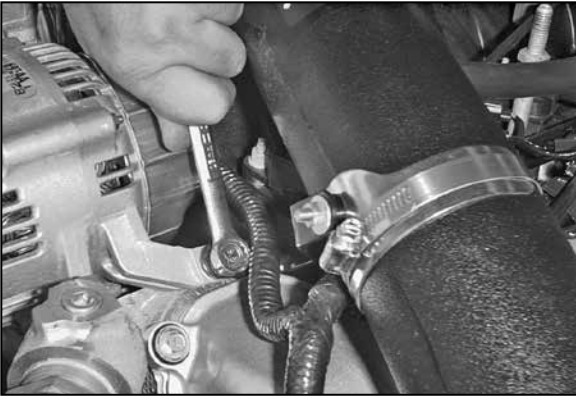

25. Tighten the alternator retaining bolt.



26. Attach the vent hose provided to the "T" fitting.

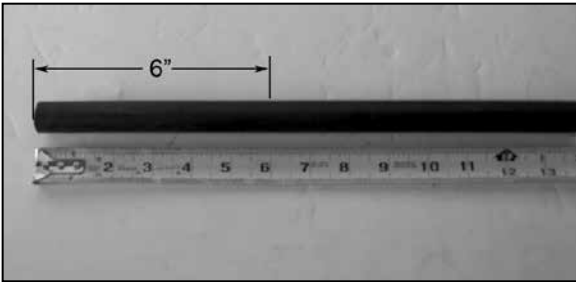

26a. On 03 models, cut 6 inches of the provided silicone hose as shown.

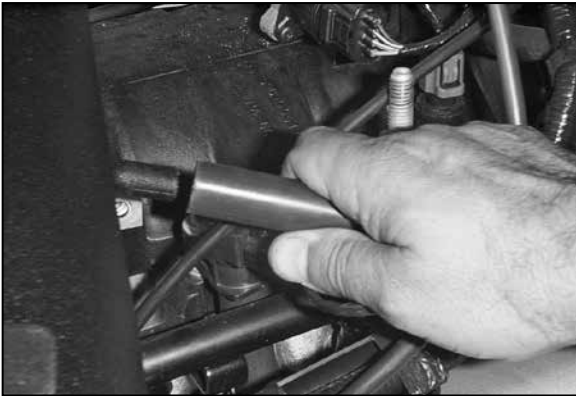

27. Attach the vent hose to the vent fitting on the K&N® intake tube.

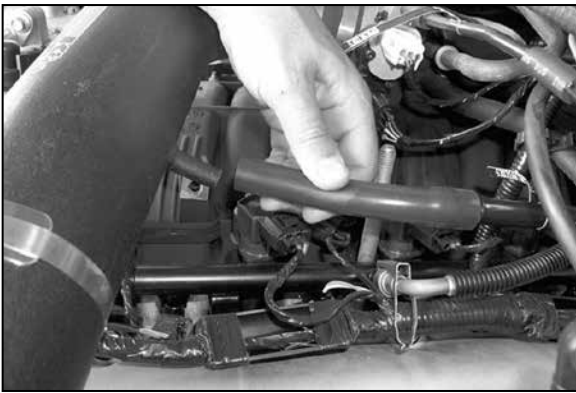

27a. On 03 models, use the 6 inch hose cut in step 27. Connect one end to crankcase vent and the other end to the intake tube as shown.



28. Install the K&N® Air Filter onto the intake tube and tighten hose clamp provided.

29. Reconnect the vehicle's negative battery cable. Double check to make sure everything is tight and properly positioned before starting the vehicle.

30. The C.A.R.B. exemption sticker, (attached), must be visible under the hood so that an emissions inspector can see it when the vehicle is required to be tested for emissions. California requires testing every two years, other states may vary.

31. It will be necessary for all K&N® high flow intake systems to be checked periodically for realignment, clearance and tightening of all connections. Failure to follow the above instructions or proper maintenance may void warranty.

ROAD TESTING:

1. Start the engine with the transmission in neutral or park, and the parking brake engaged. Listen for air leaks or odd noises. For air leaks secure hoses and connections. For odd noises, find cause and repair before proceeding. This kit will function identically to the factory system except for being louder and much more responsive.

2. Test drive the vehicle. Listen for odd noises or rattles and fix as necessary.

3. If road test is fine, you can now enjoy the added power and performance from your kit.

4. K&N Engineering, Inc., requires cleaning the intake system's air filter element every 100,000 miles. When used in dusty or off-road environments, our filters will require cleaning more often. We recommend that you visually inspect your filter once every 25,000 miles to determine if the screen is still visible. When the screen is no longer visible some place on the filter element, it is time to clean it. To clean and re-oil, purchase our filter Recharger® service kit, part number 99-5050 or 99-5000 and follow the easy instructions.

50-STATE STREET LEGAL
K&N CARB EXEMPT K&N