



FUEL INJECTION PERFORMANCE KIT FIPK

INSTALLATION INSTRUCTIONS

57-1500-1

MITSUBISHI

1991-99 3000GT

DODGE

1991-96 Stealth

V6-3.0L Standard & Twin Turbo

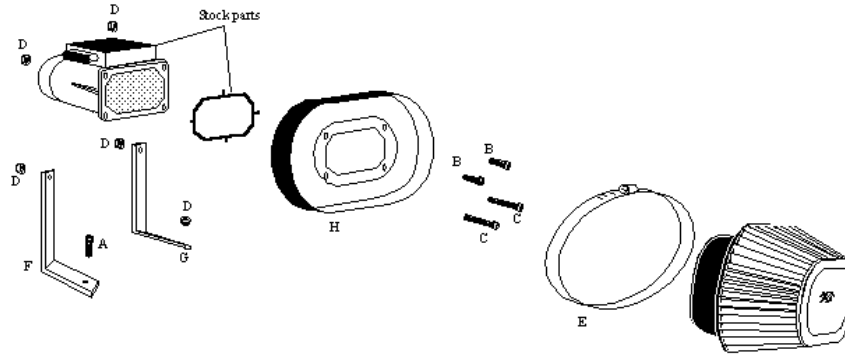

PARTS LIST:

Description	Qty.	P/N
A 6mm-1.00 x 15mm allen bolt	1	07818
B 6mm-1.00 x 20mm allen bolt	2	07852
C 6mm-1.00 x 25mm allen bolt	2	07859
D 6mm-1.00 nylock nut	5	07553
E size 104 hose clamp	1	08697
F rear "L" bracket	1	07891
G front "L" bracket	1	07882
H die-cast filter adapter	1	08846
I air filter	1	RF-1001

INSTALLATION

- 1) Disconnect the vehicle's negative battery cable.
- 2) Loosen the hose clamp where the rubber intake hose connects to the mass-air sensor.
- 3) On some vehicles with a manual transmission; you may need to unhook the vacuum pipe from the rubber hose junction. (see fig. 1)
- 4) Carefully remove the electrical plug connection from the mass-air sensor.
- 5) Unclip the airbox lid. Remove the airbox lid and the mass-air sensor from the car as a unit.
- 6) Unbolt the airbox assembly from the body. It is held in place with two bolts and one nut. Be careful not to drop any parts.
- 7) There is a small metal bushing in the grommet with the stud, carefully remove this with needle-nose pliers.
- 8) Remove the airbox with the snorkel tube attached. It is a tight fit, so be patient and work it out carefully.
- 9) Remove the mass-air sensor from the airbox lid, which is held by four nuts.
- 10) Install the filter adapter to the mass-air sensor, re-using the stock rubber gasket. (see fig. 2)
- 11) Install the two "L" brackets as shown. Be certain that the brackets are positioned correctly, there is a slight angularity difference between the two. Leave all fasteners slightly loose at this time.
- 12) Install the mass-air sensor into the vehicle. Work the front bracket over the stud, as the sensor slides into the intake hose.
- 13) Install a nylock nut on the stud and a 15mm long allen bolt in the rear bracket. Gently tighten all fasteners (6) at this time.
- 14) Tighten the hose clamp on the intake hose.
- 15) Plug the electrical connector into the mass-air sensor.
- 16) Re-connect the vacuum pipe if the vehicle has a manual transmission. (see fig. 1)
- 17) Install K&N air filter onto adapter, do not over-tighten hose clamp!
- 18) Re-connect battery cable. Double check to make sure everything is tight and properly positioned before starting vehicle.
- 19) The C.A.R.B. exemption sticker, (attached) must be placed in a visible area under the hood, so that an emissions inspector can see it when the vehicle is required to be tested for emissions. California requires testing every two years, other states may vary.
- 20) It will be necessary for all FIPK's to be checked periodically for realignment, clearance and tightening of all connections. Failure to follow the above instructions or proper maintenance may void warranty.

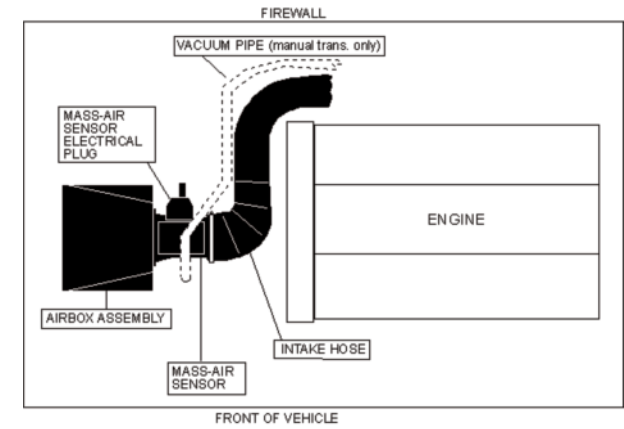

**NON-TURBO
ENGINE COMPARTMENT**

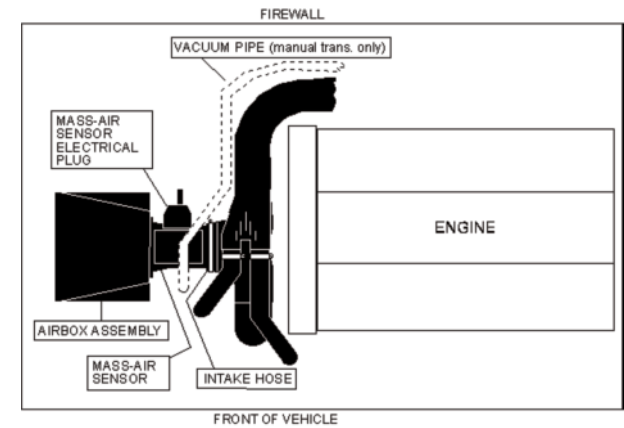

**TWIN-TURBO
ENGINE COMPARTMENT**

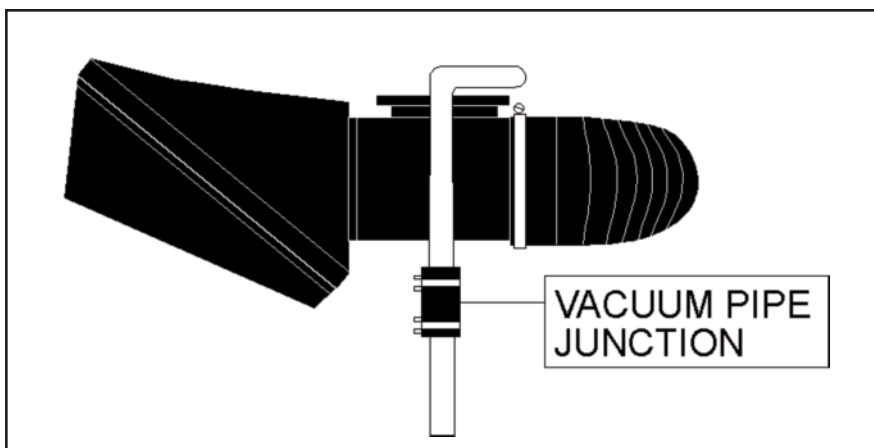

fig. 1

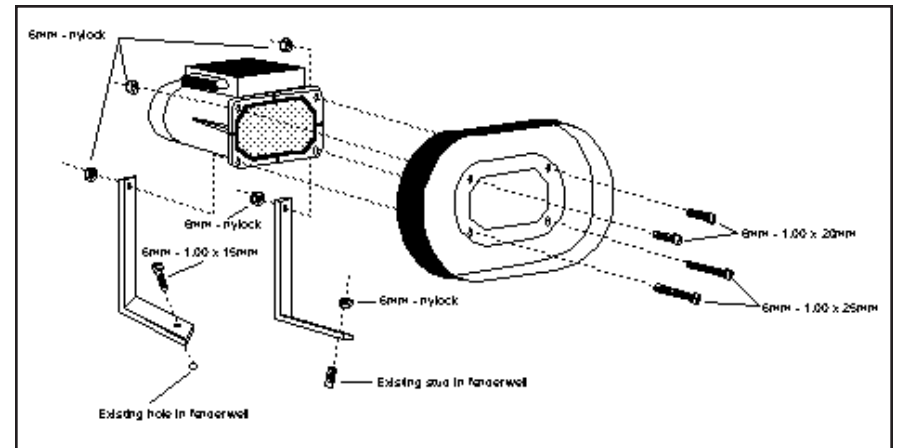

fig. 2