

**PLEASE READ THE INSTRUCTIONS BEFORE FITTING THE KIT**

- 1 Remove the standard air box by drilling out the rivet on the air box.
- 2 Remove the air flow meter, **AFM** from the intake pipe and cut off the small plastic locator, **Drawing A**. When returning the system to standard, the airbox intake will still locate correctly with the side clips.
- 3 Fit the new bracket to the inner wing, **Drawing B & D** using screw, washer and nut supplied.
- 4 Refit the **AFM** to the intake hose. Fit the air filter but **don't overtighten** the clip.
- 5 Attach a long plastic tie around the air filter neck and through the hole in the bracket. **Don't overtighten** the plastic tie, **Drawing C**.
- 6 **Cold air system**  
**Carefully** expand the hose to approx. 18"/46cm. Elongate one end of the hose to fit behind the grille, **Drawing E & F**. Using a plastic tie attach the hose to the hole in the metal undertray. Feed the hose upwards to finish 4"/10cm from the filter, **no nearer**. Using a plastic tie attach hose as **Drawing D & F**.
- 7 **Tuning. CAT. cars, no adjustments are required.**  
**Non CAT. cars**, we suggest that a simple **CO** test is carried out, as some cars may be set weaker than the standard setting. The **CO** figure should not be set at more than **0.5%** above the recommended figure.
- 8 **Filter Maintenance**  
Under normal conditions clean and reoil the filter at approx. 40000 miles/65000 km. **Use only K&N cleaner** and oil and follow the instructions carefully.

**K&N filters are pre oiled ready to fit.**

**The advantages of K&N's cold [air intake system](#)**

Cooler air, being denser, will show positive improvements in power over filter systems that draw hot air from the engine bay.

**This Kit Should Contain :-**

- 1 x Clamp-on filter.
- 1 x Hose clip size 48.
- 1 x Bracket.
- 1 x Cold air hose assembly.
- 1 x Instruction sheet.
- 1 x Instruction pack:-
  - 1 x Filter maintenance sheet.
  - 1 x K&N window sticker.
  - 1 x Million mile warranty card.
  - 1 x Leaflet.
- 1 x Fixing kit containing :-
  - 1 x M6 x 12 hex screw.
  - 1 x M6 hex nut.
  - 1 x 6mm spring washer.
  - 2 x Plastic cable ties (35cm long).

**IMPORTANT INSTRUCTIONS  
FOR ROUND ENTRY  
CLAMP ON AIR FILTERS**

Gently tighten the hose clip to the point where the filter will just rotate on the pipe or intake flange. Reposition the K&N logo straight, then **give the clip two turns i.e. 360 , no more.**

**FITTING YOUR OWN 57i KIT**

If not, **it is essential** that the person fitting the kit (e.g. mechanic) **carefully follows these particular instructions** even if he has fitted K&N kits before. This will save you both time and money. Kits incorrectly fitted may show a loss in performance e.g. the positioning of the essential cold air hose, (flexi expandable and rubber hoses are used).

**A final check** under the bonnet, by yourself, with the instructions, would seem sensible.

### Drawing A

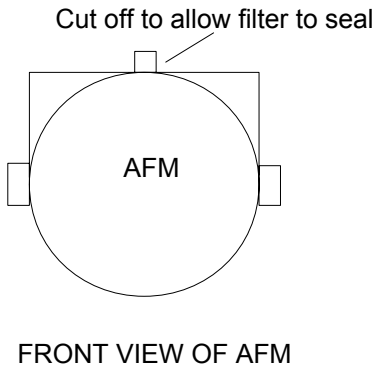

### Drawing B

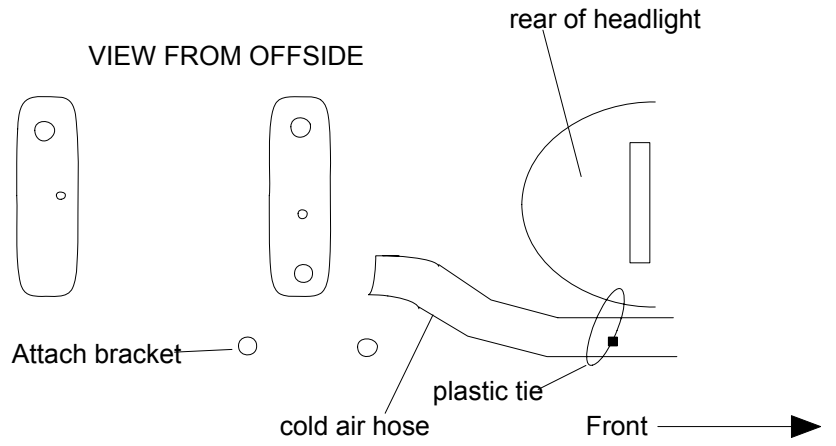

### Drawing C

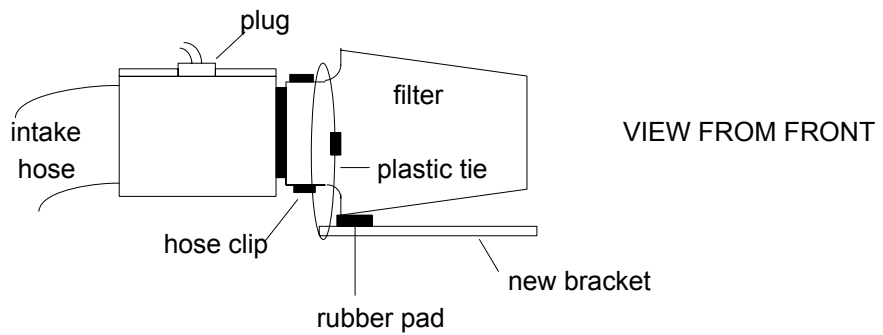

### Drawing D

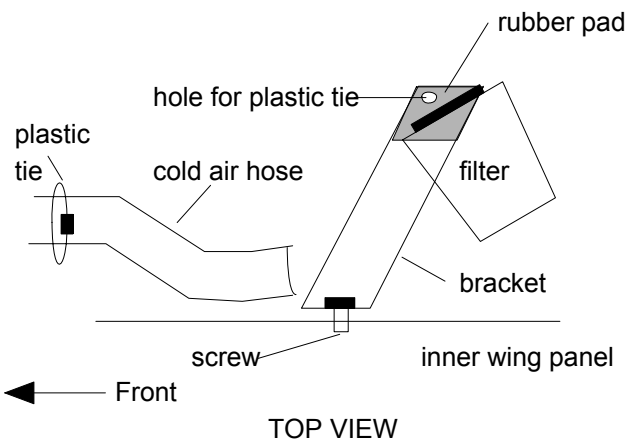

### Drawing E

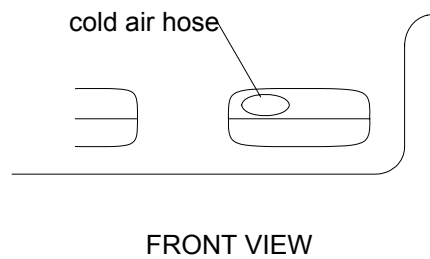

### Drawing F

