



AIRCHARGER®

HIGH-FLOW INTAKE KITS

INSTALLATION INSTRUCTIONS

63-3090

CHEVROLET

2015-16 Corvette Z06

V8-6.2L Supercharged

TOOLS NEEDED:

- Flat blade Screw driver
- Phillips screw driver
- 3mm allen key
- 10mm socket
- 10mm wrench
- Ratchet
- Extension
- pliers
- T25 torx
- razor knife

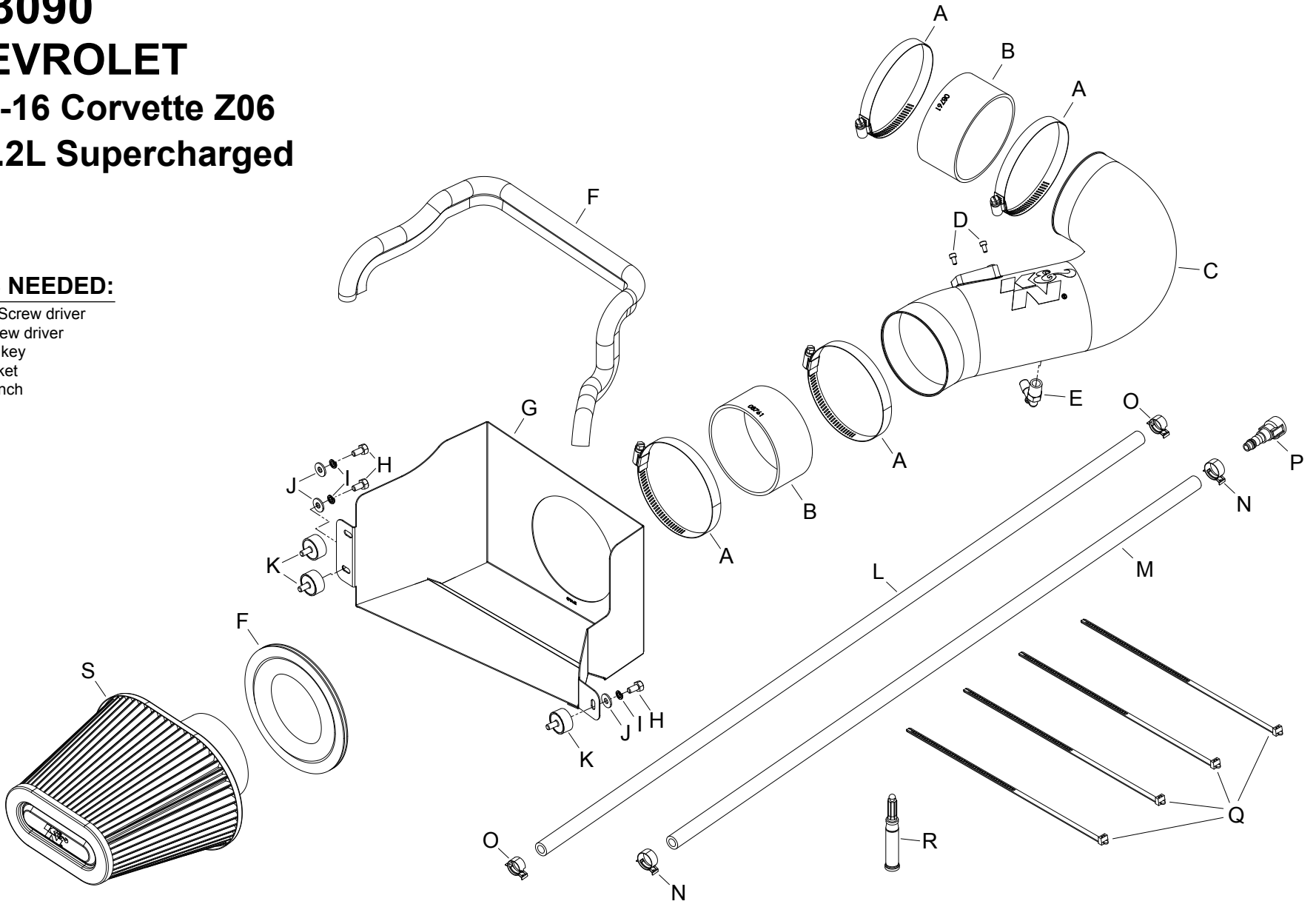

PARTS LIST:

Description	Qty.	Part #	Description	Qty.	Part #	Description	Qty.	Part #
A hose clamp #64, black zinc	4	08645K	H bolt; m6 x 1.00 x 12mm, ss	3	07727	O hose clamp; spring band	2	08552
B hose; 4" id x 2" l reinforced	2	08761	I washer, m6 split lock zinc	3	1-3025	P fitting; 3/8id quick disconnect	1	082629
C intake tube	1	087302	J washer; 6mm flat, ss	3	08269	Q cable ties; 11" black	4	21590
D bolt; m4 - 0.07 8mm, a/h cap, ss	2	07733	K stud; rubber mnt, m/f, 1/2"l x 1"w	3	070228	R super glue, 3g drip proof	1	409
E vent; 1/4npt, 90deg., 3/8" hose	1	08523	L hose; 3/8" id x 40"l, vent, sae 30r7	1	08635	S air filter	1	RP-5285
F edge trim (44")	1	102486	M hose; 3/8" id x 38"l, reinforced	1	08636			
G heat shield	1	073162	N hose clamp; spring band 20mm	2	08553			

NOTE: FAILURE TO FOLLOW INSTALLATION INSTRUCTIONS AND NOT USING THE PROVIDED HARDWARE MAY DAMAGE THE INTAKE TUBE, THROTTLE BODY AND ENGINE.

TO START:

1. Turn off the ignition and disconnect the negative battery cable.
NOTE: Disconnecting the negative battery cable erases pre-programmed electronic memories. Write down all memory settings before disconnecting the negative battery cable. Some radios will require an anti-theft code to be entered after the battery is reconnected. The anti-theft code is typically supplied with your owner's manual. In the event your vehicles anti-theft code cannot be recovered, contact an authorized dealership to obtain your vehicles anti-theft code.



2. Remove the four bolts that secure the air extraction duct to the radiator and then remove the air extraction duct from the vehicle.



3. Release the grey locking tabs securing the crank case breather assembly to the factory intake tube and the oil tank. Then remove the crank case breather assembly from the vehicle.



4. Release the red locking tab securing the mass air sensor electrical connection and then disconnect the mass air sensor electrical connection.



5. Loosen the two hose clamps that secure the factory intake tube to the throttle body and to the air filter housing and then remove the factory intake tube from the vehicle.



6. Loosen the two screws that secure the mass air sensor housing the air filter housing and then remove the housing and factory air filter.



7. Remove the two bolts that secure the air filter housing to the inner fender and then remove the housing from the vehicle.



8. Remove the air filter housing mounting stud from the inner fender.



9. Assemble the coolant hose (08636), spring clamp and quick disconnect fitting as shown and then install the other spring clamp 1.5" from the open end of the hose as shown.
NOTE: Slip joint pliers can be used to collapse the clamps for installation.



10. **WARNING: Be sure the engine is completely cool before proceeding with this step!** Release the blue locking tap securing the factory coolant hose to the expansion tank and then disconnect the hose from the tank.
NOTE: Be sure to collect any coolant that may escape from the tank and hose.



11. Using a razor knife, cut the plastic hose at the TEE fitting as shown. Separate the hose from the TEE fitting.

NOTE: be careful cutting the plastic hose so as not to cut too deep. It may be beneficial to make several shallow passes while cutting to prevent cutting into the TEE fitting. Be sure to capture any lost coolant that may escape from the hose or TEE fitting.



12. Install the previously assembled coolant hose assembly onto the expansion tank and then route it to the TEE fitting. Install hose onto the TEE fitting and secure with the provided spring clamp. Use the provided tie wraps to secure the hose where shown.



13. Release the spring clamp securing the coolant hose from the thermostat housing to the TEE fitting and then disconnect the hose from the TEE fitting.
NOTE: Be sure to collect any coolant that is lost.



14. Cut 2" from the coolant hose and reinstall it onto the fitting and secure with the factory spring clamp.



15. Install the three provided rubber mounted studs onto the air filter housing mounting locations as shown.

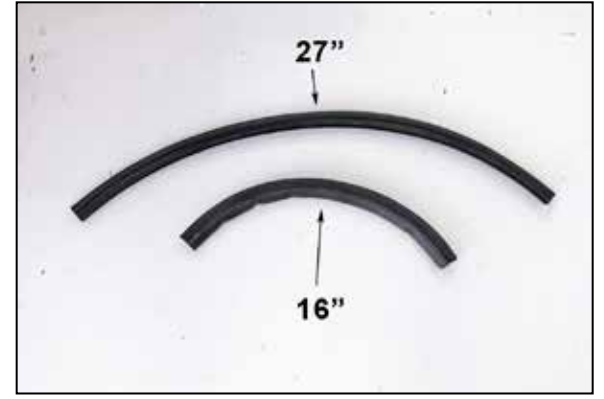

16. Cut the provided edge trim into two sections, one section will be 27" long and the other section will be 16" long.

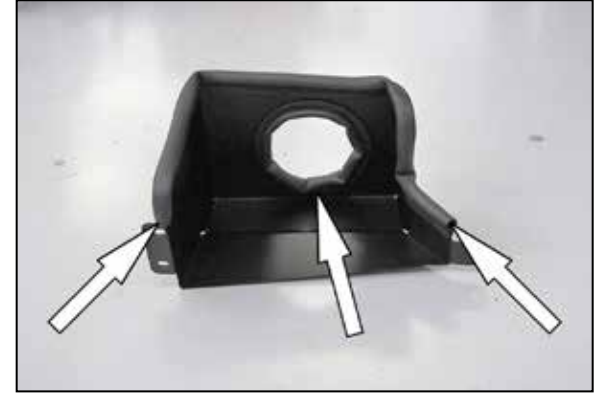

17. Install the 16" long edge trim into the hole of the heat shield and install the 27" long section around the edge of the heat shield as shown.

NOTE: Use the provided super glue on the ends of the edge trim to hold it down.



18. Set the air filter into the heat shield and then install the coupling hose (08761) onto the filter and secure with the provided hose clamp.



19. Install the heat shield/filter assembly onto the rubber mounted studs installed during step #13 and secure with the provided hardware.



20. Install the provided coupling hose (08761) onto the throttle body and secure with the provided hose clamp.



21. Remove the two screws that secure the mass air sensor into the housing and then remove the mass air sensor from the housing.



22. Install the mass air sensor into the K&N® intake tube and secure with the provided hardware.



23. Install the provided 90° npt fitting into the K&N® intake tube as shown.

NOTE: Plastic NPT fittings are easy to cross thread. Install the vent fitting "hand" tight, then turn it two complete turns with a wrench.



24. Install the K&N® intake tube into the heat shield and air filter and then into coupling hose at the throttle body. Adjust the tube and filter for best fit and then secure with the provided hose clamps.



25. Install the provided crank case breather hose onto the fitting on the oil tank and then onto the fitting on the K&N® intake tube and secure with the provided spring clamps. Secure the hose as shown with the provided tie wraps.



26. Reconnect the mass air sensor electrical connection.



27. Reinstall the air extraction duct and secure with the provided hardware.



28. Reconnect the vehicle's negative battery cable. Double check to make sure everything is tight and properly positioned before starting the vehicle.

29. It will be necessary for all K&N® high flow intake systems to be checked periodically for realignment, clearance and tightening of all connections. Failure to follow the above instructions or proper maintenance may void warranty.

ROAD TESTING:

1. Start the engine with the transmission in neutral or park, and the parking brake engaged. Listen for air leaks or odd noises. For air leaks secure hoses and connections. For odd noises, find cause and repair before proceeding. This kit will function identically to the factory system except for being louder and much more responsive.

2. Test drive the vehicle. Listen for odd noises or rattles and fix as necessary.

3. If road test is fine, you can now enjoy the added power and performance from your kit.

4. K&N Engineering, Inc., requires cleaning the intake system's air filter element every 100,000 miles. When used in dusty or off-road environments, our filters will require cleaning more often. We recommend that you visually inspect your filter once every 25,000 miles to determine if the screen is still visible. When the screen is no longer visible some place on the filter element, it is time to clean it. To clean and re-oil, purchase our filter Recharger® service kit, part number 99-5050 or 99-5000 and follow the easy instructions.