



# INSTALLATION INSTRUCTIONS

**57-2583**

**FORD**

**2011-14 F150**

**V6-3.5L Ecoboost**

**NOTE:** This kit was not designed to fit vehicles with a body lift.

**TOOLS NEEDED:**

- Ratchet
- Extension
- 5/16" Socket
- 4mm Socket
- T20 Torx
- 9/16" Wrench
- 4mm Allen
- 3mm Allen
- Flat Blade Screwdriver

**PARTS LIST:**

Description	Qty.	Part #	Description	Qty.	Part #
A Hose Clamp #44 Stainless	2	08560	M Vent; STRT, 3/8" Hose, 1/4"NPT, Plas.	1	08047
B Hose; 3" ID X 2"L Reinforced	1	08711	N Hose Clamp #6 Mini	1	08407
C Bolt; M6 X 1.00 X 16mm, ButtnHd, SS	5	07730	O Cable Ties; 11" Blk.	1	21590
D Washer; 6mm Flat, SS	5	08269	P Hose Clamp #56	2	08620
E Adapter; Pressure Sensor	1	088057	Q Hose; 3-1/2" ID X 2-1/2" L Hump	1	08699
F Adapter; Nylon 6/6 GF, Blk.	1	21515	R Edge Trim (39")	1	102496
G Bolt; M4-0.07 8mm, A/H Cap, SS	2	07733	S Heat Shield	1	074076
H Gasket; 3/16 Poron	1	09069	T Edge Trim (19")	1	102451
I Intake Tube	1	087257	U Adapter; Universal, 6" Filter 3.5" Coupler	1	21512-1
J Hose Clamp #64 Stainless	2	08645	V Hose Clamp #104	1	08697
K Hose; 4"ID X 2" L Reinforced	1	08761	W <a href="#">Air Filter</a>	1	RC-5173
L Plug; 1/4 NPT, Plastic, Blk.	1	08032			

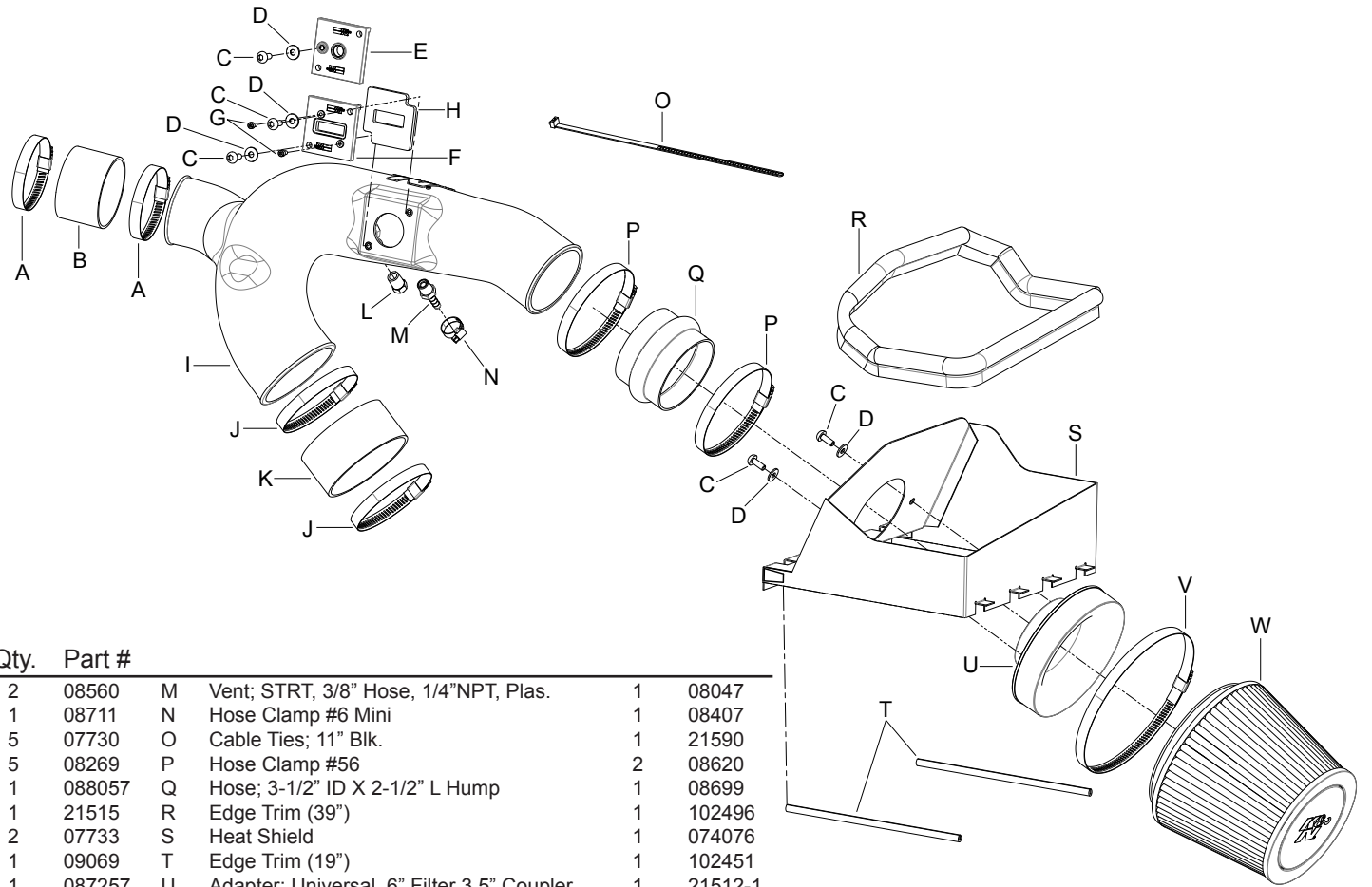

**NOTE: FAILURE TO FOLLOW INSTALLATION INSTRUCTIONS AND NOT USING THE PROVIDED HARDWARE MAY DAMAGE THE INTAKE TUBE, THROTTLE BODY AND ENGINE.**

**TO START:**

1. Turn off the ignition and disconnect the negative battery cable.  
**NOTE: Disconnecting the negative battery cable erases pre-programmed electronic memories. Write down all memory settings before disconnecting the negative battery cable. Some radios will require an anti-theft code to be entered after the battery is reconnected. The anti-theft code is typically supplied with your owner's manual. In the event your vehicles' anti-theft code cannot be recovered, contact an authorized dealership to obtain your vehicles anti-theft code.**

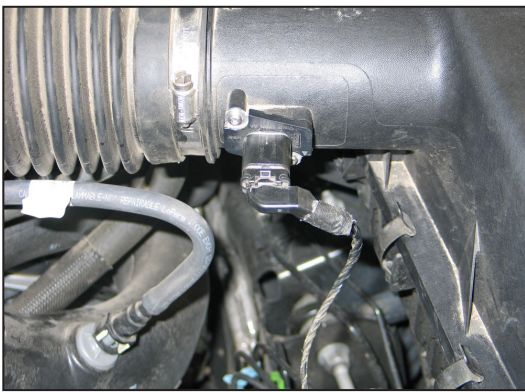

2. On vehicles equipped with a mass air sensor, release the red locking tab and then disconnect the mass air sensor electrical connection. On vehicles equipped with a pressure sensor, disconnect the electrical connection and then unhook the wiring harness from the stud.

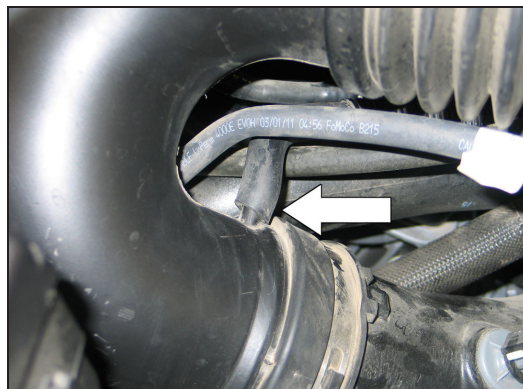

3. On vehicles equipped with the EVAP vent line, disconnect the EVAP vent line from the factory intake tube.

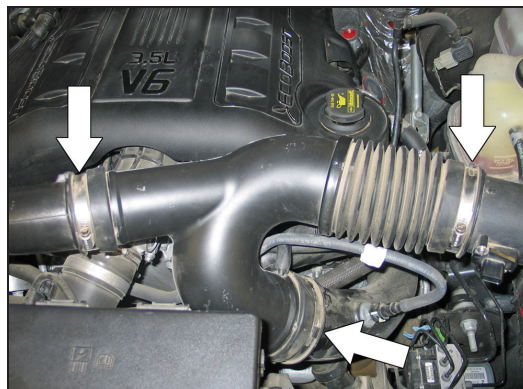

4. Loosen the three hose clamps securing the factory intake tube.

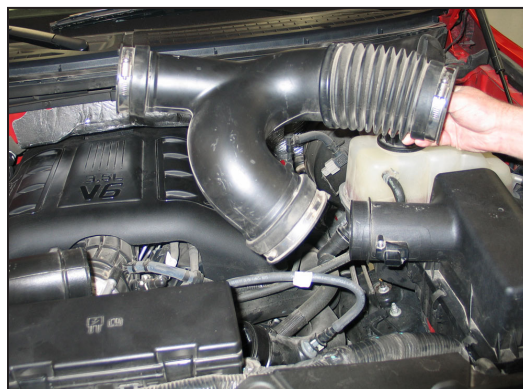

5. Remove the factory intake tube as shown. **NOTE: DO NOT remove the air diverters from the factory turbo inlet tubes.**



6. Release the three locking tabs and then lift up and remove the upper air box from the vehicle. **NOTE: K&N Engineering, Inc., recommends that customers do not discard factory air intake.**



7. Install the filter adapter into the heat shield and secure with the provided hardware.

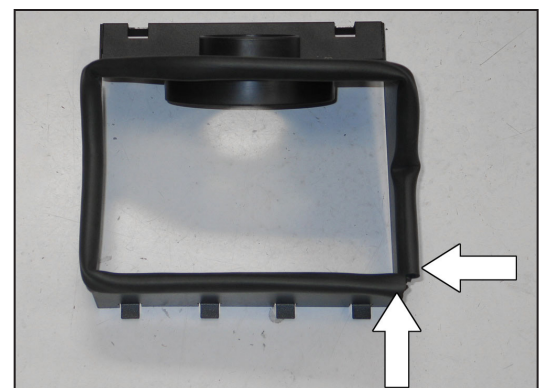

8. Install the provided "Top Bulb" edge trim around the top of the heat shield. **NOTE: Some trimming of the edge trim will be necessary.**

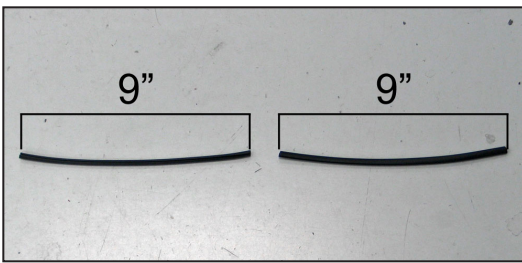

9. Cut the provided 1/16" gap edge trim into two sections 9" long.

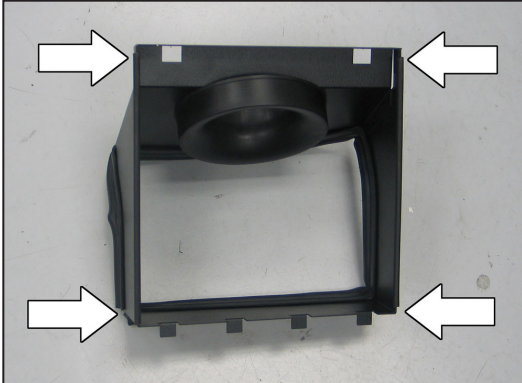

10. Install the 1/16" gap edge trim onto the bottom of the heat shield as shown.



11. Install the K&N® air filter onto the filter adapter and secure with the provided hose clamp.  
**NOTE: Drycharger® air filter wrap; part # RC-5173DK is available to purchase separately.**



12. Install the provided silicone hump hose (08699) onto the filter adapter and secure with the provided hose clamp.

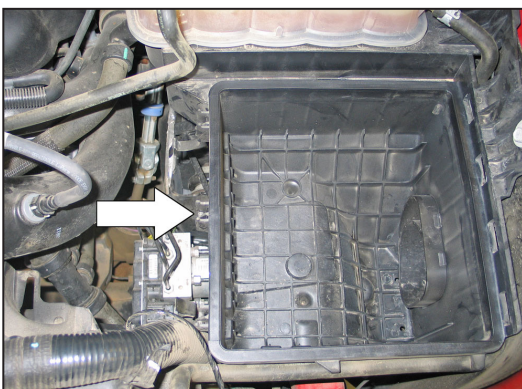

13. Remove the center upper air box retaining clip from the lower air box.



14. Install the air filter/heat shield assembly onto the lower air box and secure with the two remaining air box clips.

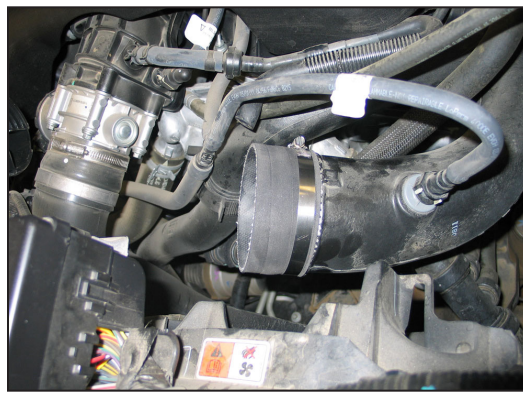

15. Install the provided silicone hose (08761) onto the driver's side turbo inlet tube and secure with the provided hose clamp.

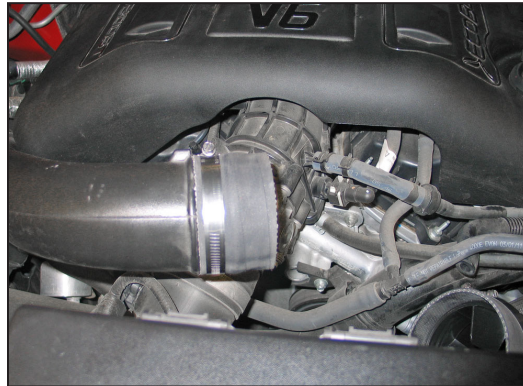

16. Install the provided silicone hose (08711) onto the passenger side turbo inlet tube and secure with the provided hose clamp.

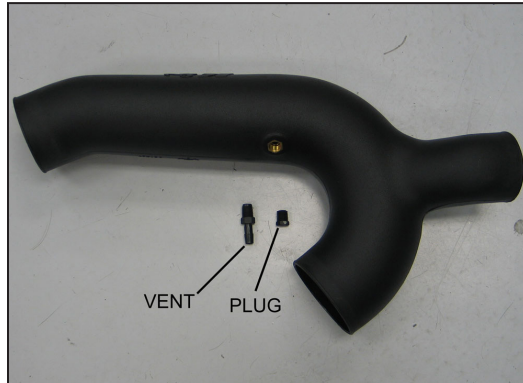

17. On vehicle equipped with an EVAP vent line, install the npt vent fitting into the K&N® intake tube. On vehicles not equipped with an EVAP vent line, install the npt plug.  
**NOTE: Plastic NPT fittings are easy to cross thread. Install the vent fitting "hand" tight, then turn it two complete turns with a wrench.**

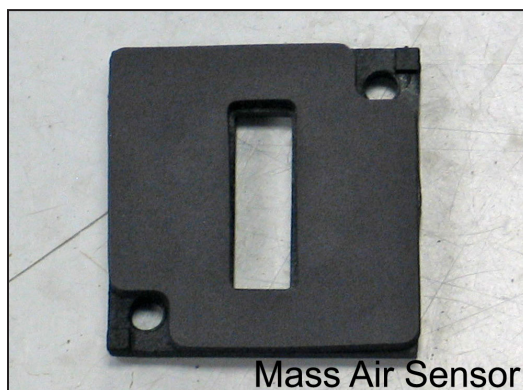

Mass Air Sensor

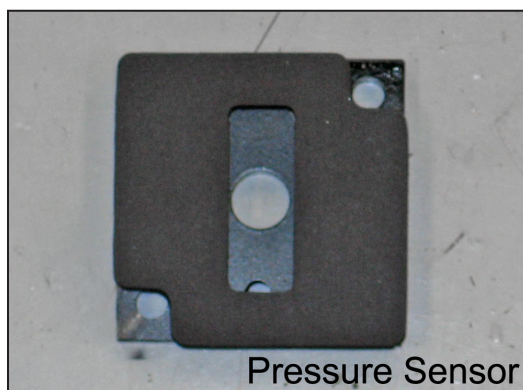

Pressure Sensor

18. With vehicles equipped with a mass air sensor, install the provided gasket onto the mass air sensor adapter. On vehicles equipped with a pressure sensor, install the provided gasket onto the pressure sensor adapter as shown.

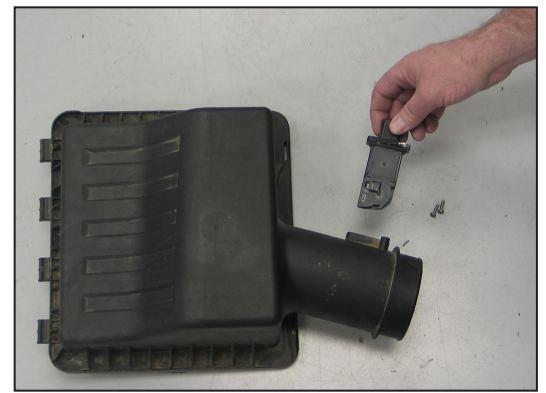

19. If the vehicle is equipped with a mass air sensor, remove the two bolts securing the mass air sensor into the factory air box and then remove the sensor from the air box.

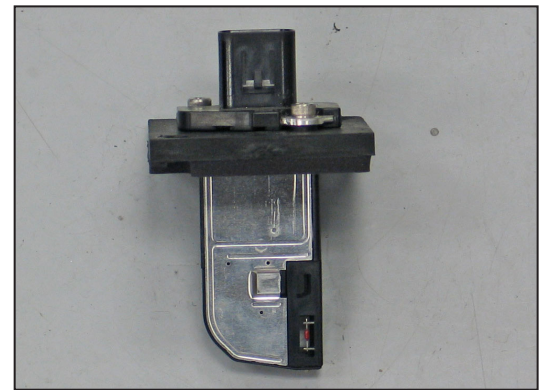

20. Install the mass air sensor into the mass air sensor adapter and secure with the provided hardware.



21. Install the mass air sensor assembly into the K&N® intake tube and secure with the provided hardware.  
**NOTE: The opening in the mass air sensor should be oriented to face the filter end of the tube.**



22. If the vehicle is equipped with a pressure sensor, remove the bolt securing the pressure sensor into the factory air box, and then remove the sensor from the air box.

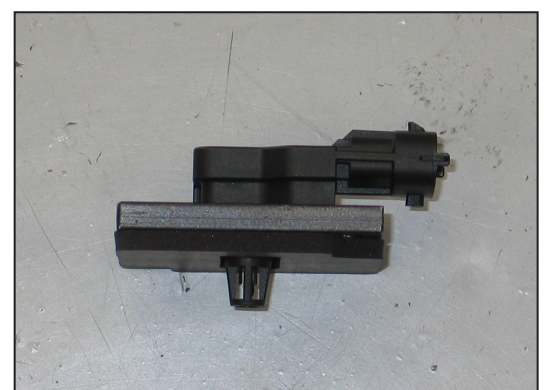

23. Install the pressure sensor into the pressure sensor adapter and secure with the provided hardware.



24. Install the pressure sensor assembly into the K&N® intake tube and secure with the provided hardware.

**NOTE: The electrical connector should be oriented downward once installed.**



25. Install the K&N® intake tube assembly, attaching each inlet into the silicone hoses previously installed. Secure the intake tube with the provided hose clamps.



26. On vehicles equipped with an EVAP vent line, install the EVAP vent hose onto the vent fitting and secure with the provided hose clamp.



27. Reconnect the mass air sensor or pressure sensor electrical connection. Secure the sensor wiring harness to the main harness with the provided tie wrap.

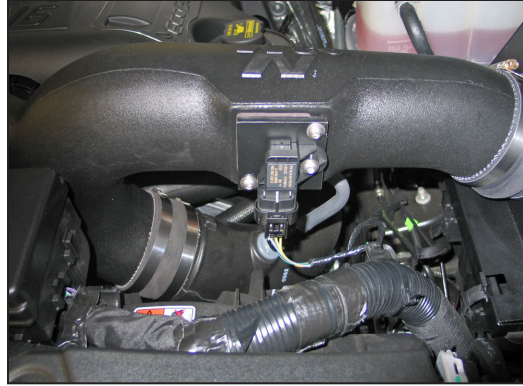

28. Reconnect the vehicle's negative battery cable. Double check to make sure everything is tight and properly positioned before starting the vehicle.



29. The C.A.R.B. exemption sticker, (attached), must be visible under the hood so that an emissions inspector can see it when the vehicle is required to be tested for emissions. California requires testing every two years, other states may vary.

30. It will be necessary for all K&N® high flow intake systems to be checked periodically for realignment, clearance and tightening of all connections. Failure to follow the above instructions or proper maintenance may void warranty.

#### ROAD TESTING:

1. Start the engine with the transmission in neutral or park, and the parking brake engaged. Listen for air leaks or odd noises. For air leaks secure hoses and connections. For odd noises, find cause and repair before proceeding. This kit will function identically to the factory system except for being louder and much more responsive.

2. Test drive the vehicle. Listen for odd noises or rattles and fix as necessary.

3. If road test is fine, you can now enjoy the added power and performance from your kit.

4. K&N Engineering, Inc., requires cleaning the intake system's air filter element every 100,000 miles. When used in dusty or off-road environments, our filters will require cleaning more often. We recommend that you visually inspect your filter once every 25,000 miles to determine if the screen is still visible. When the screen is no longer visible some place on the filter element, it is time to clean it. To clean and re-oil, purchase our filter Recharger® service kit, part number 99-5050 or 99-5000 and follow the easy instructions.