



TUNDRA-734/230
INSTALLATION MANUAL





TUNDRA-734/230

Installation and Operation Manual

Table of Contents

1. LIST OF FIGURES
2. How to Use this Manual
 - 2.1. Interactive Manual using Adobe Reader
 - 2.2. Your Kit SKU Number and this Manual
 - 2.3. Illustration/Photo Details and Orientation
3. Safety First
4. Application Chart
 - 4.1. 100% Direct Bolt-On Vehicle List
 - 4.2. **Excluded Vehicles
 - 4.3. Aftermarket Product Compatibility
5. Installation Overview
 - 5.1. Kit Layout and System Location(s)
 - 5.2. Approximate Installation Time
 - 5.3. ***Quick Install Outline
6. List of Tools and Supplies
 - 6.1. Standard Tool List (Required)
 - 6.2. Special Tool List (Recommended)
 - 6.3. Shop Consumables List (Recommended)
7. Parts List
 - 7.1. Parts List covers following SKU Numbers
 - 7.2. Pre-Packaged Electro-Mechanical Items
 - 7.3. Air Fittings and Related Items
 - 7.4. Electrical Small Components and Related Items
 - 7.5. Bolt-On Mounting Brackets & Special Hardware
 - 7.6. Hardware/Fasteners
8. On-Vehicle Electrical Installation
 - 8.1. Relay and Fuse Diagram for Air Horn System
 - 8.2. Review suggested Wire Routing for Air Horn System
 - 8.3. Disconnect Vehicle Battery(s)
 - 8.4. Connect Wiring to Relay(s) and Fuse(s), then Attach to Vehicle
 - 8.5. Connect Air Horn Solenoid(s)
 - 8.6. Pressure Switch



TUNDRA-734/230

Installation and Operation Manual

9. Bench Assembly Steps
 - 9.1. Disassemble Air Horn Kit
 - 9.2. Assemble Air Tank Fittings to Air Tank
10. On-Vehicle Mechanical Assembly Steps
 - 10.1. Primary Crossmember for Mounting Brackets
 - 10.2. Air Compressor and Bracket (TUNDRA-101) Installation
 - 10.3. Horn Bracket (TUNDRA-301) Installation
 - 10.4. Air Tank and Bracket (TUNDRA-201) Installation
 - 10.5. Air Tank Torque Strap (TUNDRA-202) Installation
 - 10.6. Connect Remote Quick Connect Kit to Vehicle
 - 10.7. Trumpet and Air Horn Driver Installation
11. Initial Testing of Kit
 - 11.1. Reconnect Vehicle Battery(s)
 - 11.2. Test Air Compressor
 - 11.3. Test Train Horns
 - 11.4. Test Quick Connect Coupler
12. General Operation of Kit
 - 12.1. Compressor Operation
 - 12.2. Horn Operation
13. Routine Maintenance



TUNDRA-734/230

Installation and Operation Manual

2. How to Use this Manual

2.1. Interactive Manual using Adobe Reader

It is recommended to open this digital PDF using Adobe Reader[®] to take advantage of following key features:

- **Hyperlinks** ([blue underlined text](#)) allow access to additional content via internet; click/tap to activate
 - Includes [Installation Figures](#) and "[Figure xx](#)"
 - **Table of Contents** page allows easily navigating this manual; click/tap any section line to go to it
 - **Bookmarks** allow quickly navigating to any section; click/tap
 - **Zoom IN** on pictures by pressing "CTRL and +" at same time on PC, or pinch in on smart devices
 - **Zoom OUT** on pictures by pressing "CTRL and -" at same time on PC, or pinch out on smart devices
-

2.2. Your Kit SKU Number and this Manual

This manual covers installation, testing, and operation of following SKU part numbers

- 2.2.1. **TUNDRA-734** (i.e., 730 Train Horn with On-Board Air System)
- 2.2.2. **TUNDRA-OBA** (i.e., On-Board Air System)
- 2.2.3. **TUNDRA-230** (i.e., 230 Train Horn with On-Board Air System)

NOTE: Illustrations and pictures contained herein may represent only one kit part number. Where critical differences exist between kits (i.e., different parts, orientation, mounting points, etc.), additional text, or necessary graphics are provided to minimize confusion.

Parts list explicitly state kit differences with **(BOLD TEXT)** inside parenthesis, shown below part number.

2.3. Illustration/Photo Details and Orientation

This manual may use digitally created illustrations, and/or actual photos of example vehicle. These graphics may not include exact items found on your vehicle (i.e., electrical wiring, fuel lines, body panels, etc.). Illustrations typically will be missing details and are for clarity to show critical mounting locations and orientation on vehicle.



Throughout manual yellow arrows with text reading "FRONT", may be present over illustrations and pictures. These arrows specify direction toward front of vehicle and provide clarity to how illustration is viewed.



TUNDRA-734/230

Installation and Operation Manual

3. Safety First

Read manual thoroughly before starting installation of this kit. Verify you have all parts listed and that you clearly understand this installation procedure. Contact Kleinn technical support for any questions.

Installation of this kit requires **moderate mechanical aptitude**; seek professional help if you're not competent using hand tools in tight uncomfortable spaces, and around possibly rusted and sharp vehicle parts.

Before starting, obtain proper tools required to perform installation correctly, adequate lighting, eye protection, hearing protection for operating train horns, and hand protection to guard against sharp edges and metal burrs, which may be present on kit parts and vehicle parts.

Throughout this manual the following words may be used; be aware of their meaning and application.

CAUTION: means damage could occur to vehicle, or kit parts during, or after installation

WARNING: means injury could occur to you or others, including damage to vehicle, or kit parts

DANGER: means serious injury or death could occur to you or others during installation



TUNDRA-734/230

Installation and Operation Manual

4. Application Chart

4.1. 100% Direct Bolt-On Vehicle List

TUNDRA-734/230 is a 100% direct bolt-on aftermarket product for Toyota vehicles listed in below chart; every effort has been made to verify correct fitment on these vehicles in their factory, non-modified conditions.

MODEL YR	MODEL	DRIVE	ENGINE	BODY	TRIM
2007-2019	TUNDRA	ALL	ALL	ALL	ALL**

NOTE: All vehicles listed may require drilling holes for ground wires and installing switches, based on preference of installed switch locations and wire grounding points.

4.2. **Excluded Vehicles

TUNDRA-734/230 is NOT compatible with following Toyota vehicles:

4.2.1. N/A

4.3. Aftermarket Product Compatibility

- 4.3.1. This kit has been designed and tested to be compatible with leading manufacturers of aftermarket truck steps, such as Amp Research Power Steps[®] and all OEM optional steps.
- 4.3.2. This kit has NOT been designed or tested for use with aftermarket exhaust systems.
- 4.3.3. This kit has NOT been designed or tested for use with aftermarket suspension/airbag systems.
- 4.3.4. This kit has NOT been designed or tested for use with aftermarket oversized fuel tanks.



TUNDRA-734/230

Installation and Operation Manual

5. Installation Overview

5.1. Kit Layout and System Location(s)

TUNDRA-734/230 consists of following sub-systems, located on vehicle, as follows:

ITEM	DESCRIPTION	MOUNTING LOCATION	APPROX. INSTALL TIME
1	730 Series Triple Horn with Air Solenoids (734 KIT ONLY) 230 Series Triple Horn with Air Solenoids (230 KIT ONLY)	Rear Crossmember, Passenger Side <i>(directly in front of rear axle)</i>	2+ Hours
2	3 Gal. Air Tank	Rear Crossmember, Passenger Side <i>(directly in front of rear axle)</i>	2+ Hours
3	6450RC Air Compressor (734KIT ONLY) 6350RC Air Compressor (230 KIT ONLY)	Rear Crossmember, Driver Side <i>(directly in front of rear axle)</i>	1-2 Hours

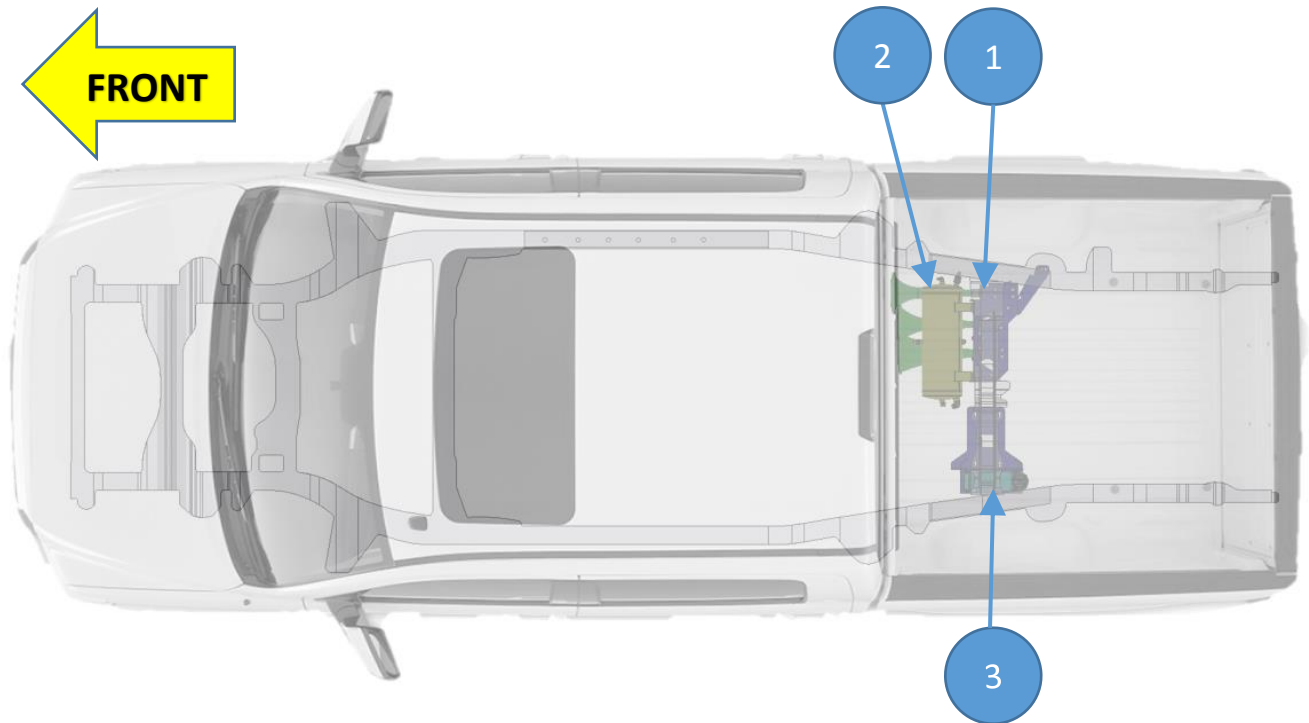

Figure A - Top View Showing Kit Layout (2018 Tundra Crew Cab Shown)



TUNDRA-734/230

Installation and Operation Manual

5.2. Approximate Installation Time

TUNDRA-734/230 is a multi-faceted product consisting of multiple mechanical, electrical, and pneumatic components.

For a typical home mechanic, auto enthusiast, or technician installing a Kleinn Bolt-On kit for first time, a professional installation job with setup and testing of final product, is estimated to take:

- **6-10 Hours**
-

5.3. ***Quick Install Outline

For person(s) with experience installing Kleinn bolt-on kits, TUNDRA-734/230 can be installed in an order similar to below:

1. Route Wiring, install Relay, and install Horn Switch
2. Bench assemble Air Fittings to Air Tank
3. Install Compressor Bracket (TUNDRA-101)
4. Install Air Compressor onto Bracket
5. Install Horn bracket (TUNDRA-301) onto crossmember
6. Install Air Tank Bracket (TUNDRA-201) onto crossmember/Horn Bracket
7. Install Air Tank onto Tank Bracket
8. Install Torque Strap (TUNDRA-202) to frame/Air Tank Bracket
9. Install Air Horns to Horn Bracket
10. Connect air lines and wiring
11. Install Quick Connect Coupler and route Air Tubing
12. Test system and adjust, as needed



TUNDRA-734/230

Installation and Operation Manual

6. List of Tools and Supplies

6.1. Standard Tool List (Required)

- 6.1.1. Basic mechanic's 3/8" drive socket sets with extensions
 - Inch Size Sockets (1/4" – 1" Hex)
 - Metric Size Sockets (6mm – 20mm Hex)
- 6.1.2. Basic mechanic's combination wrenches (box/open-end)
 - Inch Size Wrenches (1/4" – 1" Hex)
 - Metric Size Wrenches (6mm – 20mm Hex)
- 6.1.3. Basic mechanic's screwdriver set (Philips, Flat Head)
- 6.1.4. Diagonal Cutter/Wire Cutter Pliers
- 6.1.5. Wire Strippers
- 6.1.6. Wire Terminal Crimpers
- 6.1.7. Slip-Joint Pliers
- 6.1.8. Utility Knife, or Utility Razor blade
- 6.1.9. Magnetic retrieval tool

6.2. Special Tool List (Recommended)

- 6.2.1. 10-100 ft.-lb. torque wrench
- 6.2.2. 20-150 in.-lb. torque wrench
- 6.2.3. Multi-Meter for 12V DC electrical systems, or equivalent
- 6.2.4. 12V DC Test Light, or equivalent
- 6.2.5. Trim Panel Tool, for removing wiring push pins

6.3. Shop Consumables List (Recommended)

- 6.3.1. Quality Electrical tape
- 6.3.2. Di-electric grease for electrical connections
- 6.3.3. Heat Shrink tubing for electrical connections
- 6.3.4. Blue Loctite (i.e., Loctite PN 242), or equivalent
- 6.3.5. Sand Paper, or Wire Brushes for installing ground wires
- 6.3.6. Extra plastic zip ties > 6" long
- 6.3.7. Extra NPT sealant (i.e., Kleinn Air Horn Juice, Teflon tape, etc.)
- 6.3.8. Touch-up paint for frame/chassis
- 6.3.9. Typical cleanup supplies



TUNDRA-734/230

Installation and Operation Manual

7. Parts List

7.1. Parts List covers following SKU Numbers



- 7.1.1. **TUNDRA-734** (i.e., 730 Train Horns)
- 7.1.2. **TUNDRA-OBA** (i.e., On Board Air System Only)
- 7.1.3. **TUNDRA-230** (i.e., 230 Train Horns)

Unpackage and organize Kit across a large work area and verify all parts are included, as listed below. Contact Kleinn support if any questions arise.

- 7.1.4. Review pre-packaged items (i.e., train horn box, air compressor, air tank, etc.)
- 7.1.5. Review Air Fittings and Tubing
- 7.1.6. Review Wiring and Accessories
- 7.1.7. Review Bolt-On Mounting Brackets
- 7.1.8. Review Hardware/Fasteners

7.2. Pre-Packaged Electro-Mechanical Items

NOTE: Items in this section come in their own packages and may include additional items inside package







ITEM	QTY	PART NUMBER	DESCRIPTION	PICTURE
1	1	6450RC (734KIT ONLY)	6450RC Compressor Kit, with included hardware, and remote air supply line	
1	1	6350RC (230KIT ONLY)	6350RC Compressor Kit, with included hardware, and remote air supply line	
2	1	730 (734KIT ONLY)	730 Series Horn Kit, with included solenoid/valve, and 1/2" Air Tubing, 10 ft. long	
2	1	230 (230KIT ONLY)	230 Series Horn Kit, with included solenoid/valve, and 1/4" Air Tubing, 10 ft. long	



TUNDRA-734/230

Installation and Operation Manual





7.3. Air Fittings and Related Items

ITEM	QTY	PART NUMBER	DESCRIPTION	PICTURE
3	1	6350RT	Air Tank, 7-Port	
4	1	52835 (view location on Air Tank)	1/4" NPT, Drain Valve	
5	1	52175 (view location on Air Tank)	1/4" NPT, 175 PSI Safety Valve	
6	1	50040 (view location on Air Tank)	1/4" NPT Hex Plug	
7	1 (2)*	51414L (view location on Air Tank) (2) Included with 230 KIT ONLY	1/4" NPT X 1/4" Compression Fitting, 90 Deg Elbow	
8	1	2151 (view location on Air Tank)	1/4" NPT Pressure Switch	
9	1	51214R (view location on Air Tank)	1/2" NPT X 1/4" NPT Reducer Fitting	

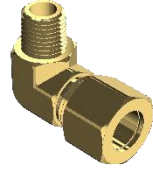

TUNDRA-734/230

Installation and Operation Manual





10	1	51214L (view location on Air Tank) (734KIT ONLY)	1/4" NPT X 1/2" Tube Fitting, 90 Deg. Elbow, Male to Female	
11	1	25014	1/4" Air Tubing, 10 ft. long (included in Quick Connect Kit)	
12	1	1302	Quick Connect Air Coupler Kit, with relocation bracket	
13	1	INF-1	Inflator Kit, with Air Hose and Bag	
14	1	KLEINN AIR HORN JUICE	Thread Sealant for NPT Fittings	



TUNDRA-734/230

Installation and Operation Manual

7.4. Electrical Small Components and Related Items

ITEM	QTY	PART NUMBER	DESCRIPTION	PICTURE
15	1	320	Terminator – Nickel Plated Remote Horn Button	
16	1	WIRE KIT	Full Wire Kit, with electrical connectors and zip ties	
17	1	1/4" WIRE LOOM, 20 ft. Long	1/4" Wire loom for electrical routing	
18	1	1/8" WIRE LOOM, 10 ft. Long	1/8" wire loom for electrical routing	



TUNDRA-734/230

Installation and Operation Manual

7.5. Bolt-On Mounting Brackets & Special Hardware

ITEM	QTY	PART NUMBER	DESCRIPTION	PICTURE
19	1	TUNDRA-101	Compressor Mounting Bracket	
20	1	TUNDRA-201	Tank Mounting Bracket	
21	1	TUNDRA-202	Torque Strap for Air Tank Bracket	
22	1	TUNDRA-301	Horn Mounting Bracket	



TUNDRA-734/230

Installation and Operation Manual

7.6. Hardware/Fasteners

ITEM NO.	PART TYPE	PART SIZE	QTY	WHERE USED
1	FLAT WASHER, USS, ZINC-PLATED	7/16" ID X 1.25" OD	2	TORQUE STRAP (2)
2	HEX NUT, GRADE 2, ZINC-PLATED	7/16"-14	1	TORQUE STRAP
3	LOCK WASHER, STANDARD SPLIT, ZINC-PLATED	7/16"	1	TORQUE STRAP
4	HEX BOLT, GRADE 2, ZINC-PLATED	7/16"-14 X 1.25" LONG	1	TORQUE STRAP
5	FLAT WASHER, USS, ZINC-PLATED	5/16" ID X 0.88" OD	14	TORQUE STRAP (1) HORN BRACKET (9) TANK BRACKET (4)
6	FLAT WASHER, FENDER, ZINC-PLATED	5/16" ID X 1.25" OD	5	TANK BRACKET (2) HORN BRACKET (2) COMPRESSOR BRACKET (1)
7	HEX NUT, GRADE 2, ZINC-PLATED	5/16"-18	17	TORQUE STRAP (1) HORN BRACKET (11) TANK BRACKET (4) COMPRESSOR BRACKET (1)
8	LOCK WASHER, STANDARD SPLIT, ZINC-PLATED	5/16"	19	TORQUE STRAP (1) HORN BRACKET (11) TANK BRACKET (6) COMPRESSOR BRACKET (1)
9	SQUARE NECK BOLT, GRADE 2, ZINC-PLATED	5/16"-18 X 1" LONG	6	TORQUE STRAP (1) HORN BRACKET (4) COMPRESSOR BRACKET (1)
10	SQUARE NECK BOLT, GRADE 2, ZINC-PLATED	5/16"-18 X 1.25" LONG	6	HORN BRACKET (6)
11	HEX BOLT, GRADE 2, ZINC-PLATED	5/16"-18 X 2" LONG	2	TANK BRACKET (2)

End of Section

8. On-Vehicle Electrical Installation

CAUTION: Follow all recommended safety precautions for working on vehicle's electrical system; consult vehicle owner's manual for further instruction.

8.1. Relay and Fuse Diagram for Air Horn System

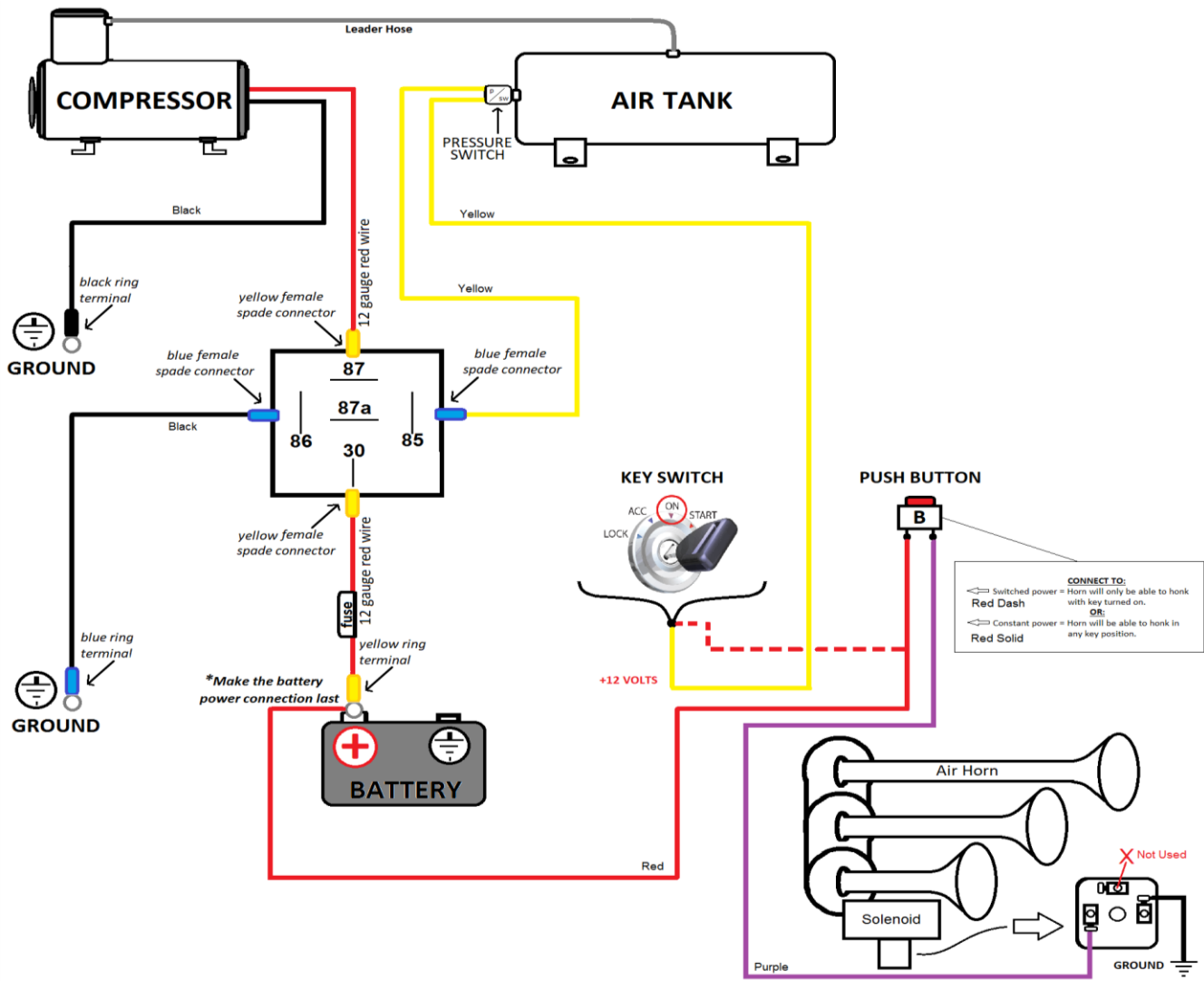

Figure 1 - Suggested Ignition Relay Diagram for Air Horn System

8.2. Review suggested Wire Routing for Air Horn System

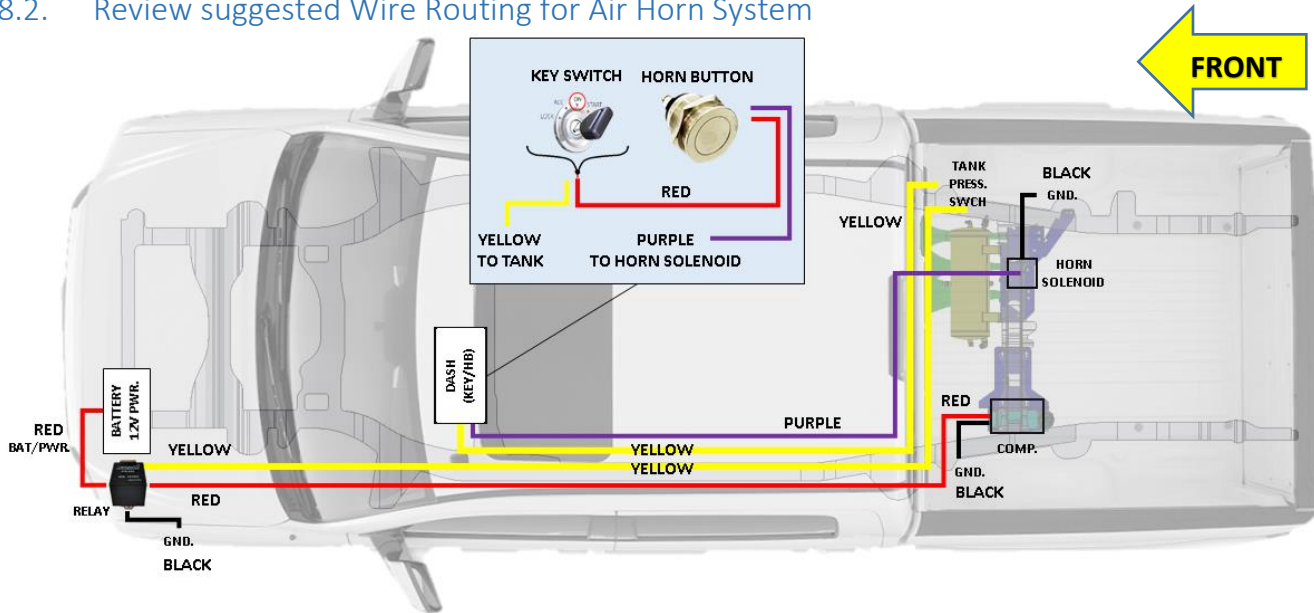

Figure 2 - Suggested Wire Routing for Horn, Air Compressor, and Pressure Switch

8.3. Disconnect Vehicle Battery(s)

8.3.1. Use special care if vehicle is equipped with any Auxiliary Auto Stop Battery. Consult Owner's Manual.

8.4. Connect Wiring to Relay(s) and Fuse(s), then Attach to Vehicle

8.4.1. Find a suitable location for supplied relay(s) and fuse(s). Shown below is an example location under hood next to battery and near grounding block. Use supplied self-tapping screws, as necessary.

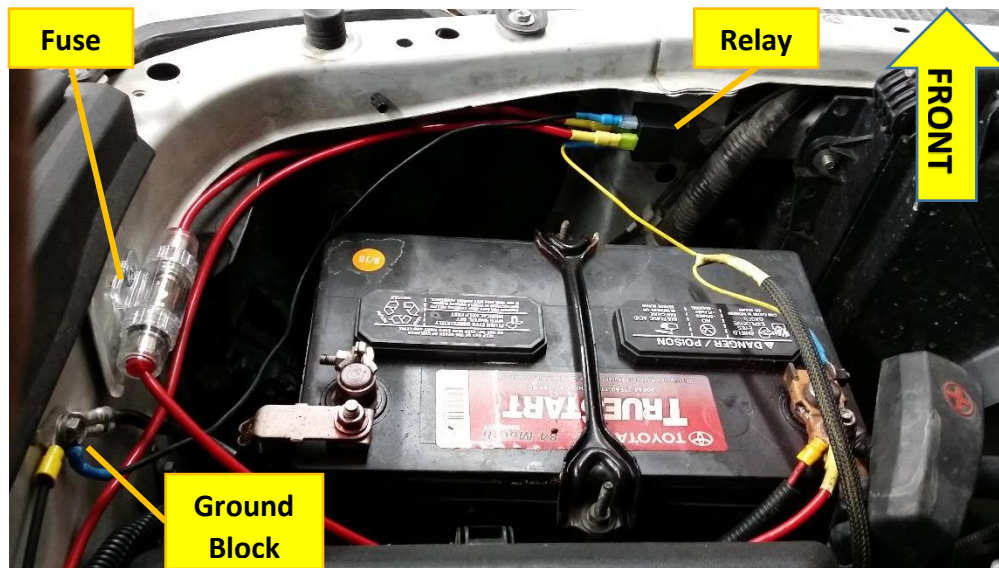

Figure 3 - Relay and Fuse Installation Example (2016 Tundra Shown)

8.4.2. Insert all wiring into included wire loom and ensure loom is away from all sharp edges, hot vehicle parts (i.e., exhaust, engine, radiator), and fasten securely to vehicle using zip ties, or equivalent.

NOTE: Do not cut wires to length until 100% sure of length required for final connections.



TUNDRA-734/230

Installation and Operation Manual

- 8.4.3. Install supplied fuse holder on end of power wire by cutting the loop in fuse holder and connecting supplied Ring terminal to one end and Butt connector on other end.

CAUTION: Do not install 30-amp fuse until all electrical connections are final.

- 8.4.4. Find a suitable location for horn push-button (i.e., in dash, center console, etc.); verify location has 1"+ of clearance behind for terminals. Mark location for drilling.

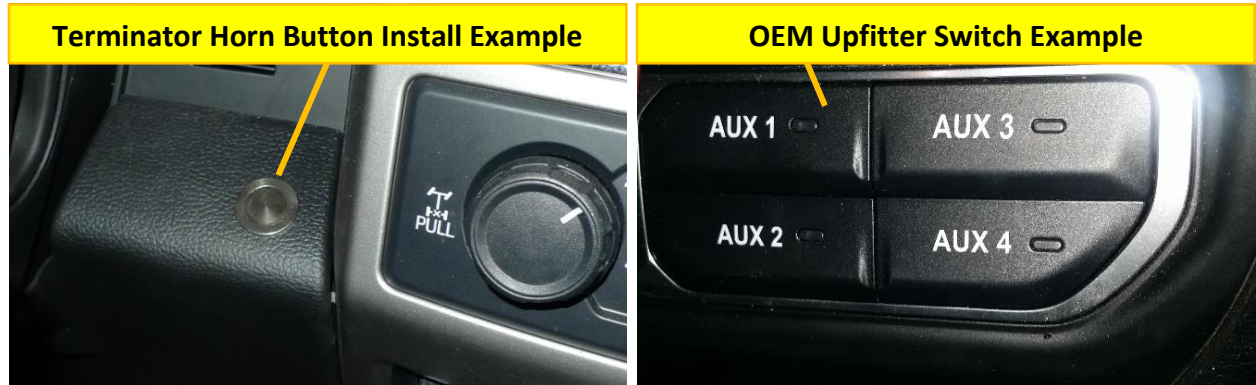

NOTE: FOR VEHICLES WITH FACTORY UPFITTER SWITCHES:

If your vehicle is equipped with factory upfitter (i.e., auxiliary) switches, you may elect to use them for your Kleinn Air Horn kit; consult Owner's Manual, or dealership for further instructions on what wire terminals to use and programming required.

- 8.4.5. Drill a 3/4" hole at location. Route horn button wires to hole then slide push-button retaining nut over wires and connect per wiring diagram. Install push-button into hole and tighten retaining nut securely on backside.

8.5. [Connect Air Horn Solenoid\(s\)](#)

- 8.5.1. Vehicle space constraints may make it difficult to connect Air Horn Solenoid(s) in-vehicle. Review install location for available space; if desired, cut and connect a section of wiring to Solenoid(s) before installing into vehicle, then perform final connection once Air Horn assembly is installed.

NOTE: If connecting upgraded Solenoid Kit (BlasterMaster Pro), see instructions contained in that package for wiring recommendations

8.6. [Pressure Switch](#)

- 8.6.1. Vehicle space constraints may make it difficult to connect Air Tank Pressure Switch in-vehicle. Review install location for available space; if desired, cut and connect a section of wiring to Pressure Switch before installing Air Tank into vehicle, then perform final connection once Air Tank is installed.

End of Section



TUNDRA-734/230

Installation and Operation Manual

9. Bench Assembly Steps

Complete following steps off vehicle to facilitate final installation.

NOTE: ALL HARDWARE WILL BE SPECIFIED IN INSTRUCTIONS USING ITEM NO.'S FOUND IN PARTS LIST. [See Parts List.](#) Assemble ALL fasteners clean and dry using proper socket and box-end wrench.

9.1. Disassemble Air Horn Kit

9.1.1. Unpackage and fully disassemble Air Horn kit; Train Horns must be separated for individual installation to Bracket (i.e., unthread Trumpets from Drivers, unbolt Drivers from metal mounting bar, cut lines).

9.2. Assemble Air Tank Fittings to Air Tank

9.2.1. Apply two small drops of [Kleinn Air Horn Juice](#) to each male pipe thread.

9.2.2. Attach air fittings to tank, per below illustration.

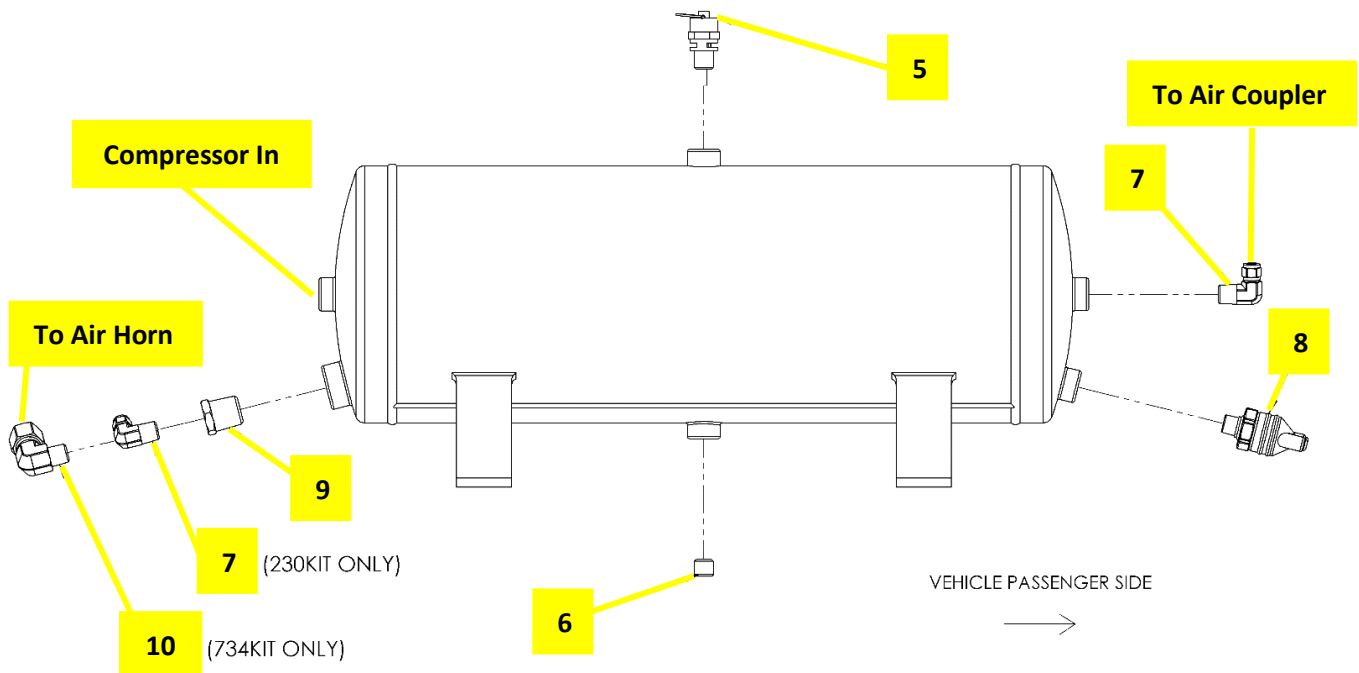

Figure 4 - Tank Air Fittings Exploded (Top View from above Vehicle)



TUNDRA-734/230

Installation and Operation Manual

9.2.3. Ensure outlet fitting for horns is at 45 degree angle towards front of vehicle as shown in [Figure 17 below](#).

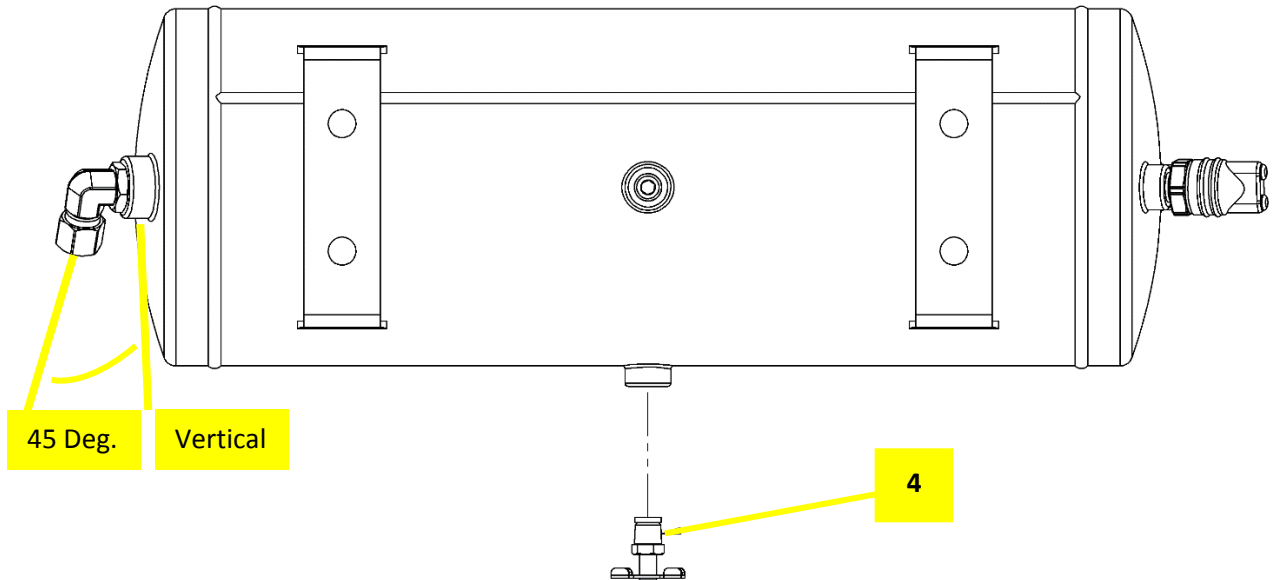

Figure 5 - Tank Air Fittings Exploded (Back View from Behind Vehicle)

9.2.4. Hand-tighten each fitting, then further tighten each 1/4-1/2 turn using proper sized box-end wrench; adjust as necessary to match fitting orientation shown in figures above.

End of Section



TUNDRA-734/230

Installation and Operation Manual

10. On-Vehicle Mechanical Assembly Steps

Complete following steps *on vehicle*.

Raise vehicle off ground using appropriate vehicle lift, ramps, or jack stands.

DANGER: Installation requires being underneath vehicle and applying forces to vehicle chassis. Follow all recommended safety precautions for raising vehicle; consult vehicle owner's manual.

NOTE: LEAVE ALL BOLTED CONNECTIONS LOOSE (unless otherwise specified) until kit is fully mounted to vehicle and desired positions are selected.

10.1. Primary Crossmember for Mounting Brackets

All Brackets for this installation will be attached to rear crossmember shown between arrows in Figure 6 below.

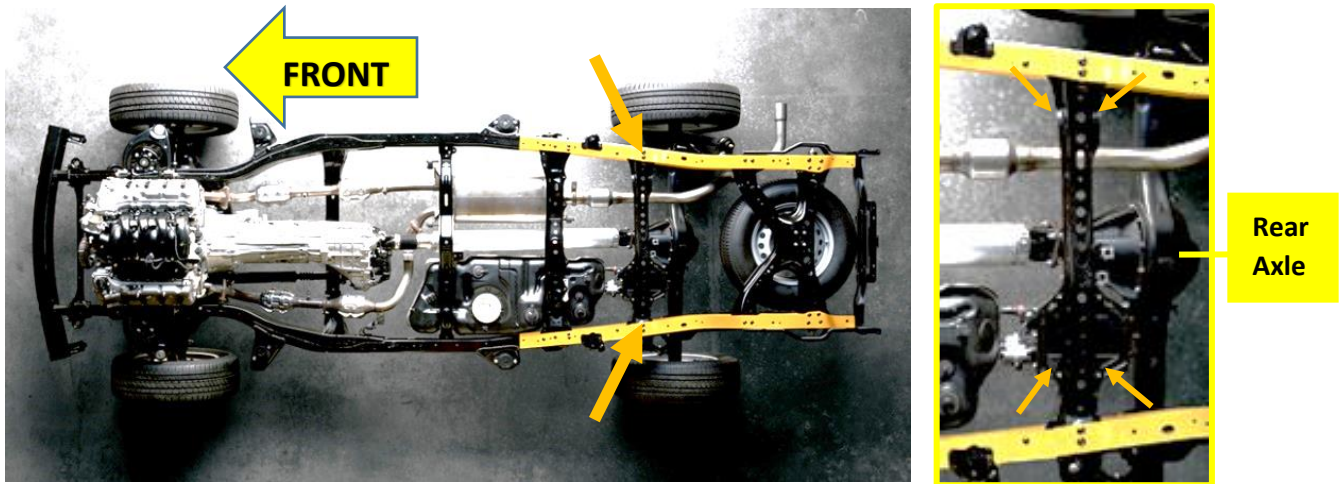

Figure 6 - Frame Reference and Crossmember Location (2007 Tundra Frame Shown)

10.2. Air Compressor and Bracket (TUNDRA-101) Installation

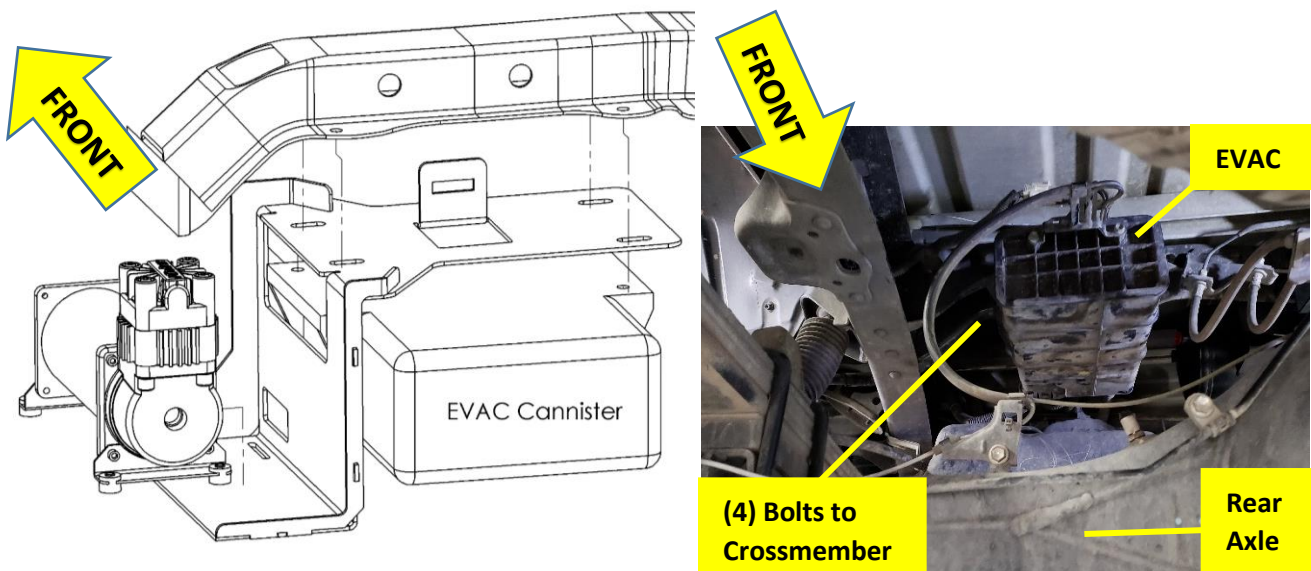

Figure 7 - TUNDRA-101 with Air Compressor and EVAC, Exploded View

- 10.2.1. Locate four (4) M8 Evaporative Cannister (i.e., EVAC) bolts going into crossmember, as shown in Figure 7 above, and Figure 8 below.
- 10.2.2. Disconnect single electrical harness above rear of EVAC, as shown circled in Figure 9 below.
- 10.2.3. Remove four (4) M8 EVAC mounting bolts; use care removing fasteners and soak with rust penetrating oil first, if necessary (i.e., WD-40, PB Blaster, etc.). Do not discard fasteners; they will be reused.
- 10.2.4. Allow EVAC to gently hang out of way, to gain access to crossmember bottom.
- 10.2.5. Place Compressor Bracket so it aligns with crossmember mount tab; use [hardware](#) #6, #7, #8, & #9 to secure mount tab with bolt going from inside of crossmember, as shown in Figure 8 and 11 below.

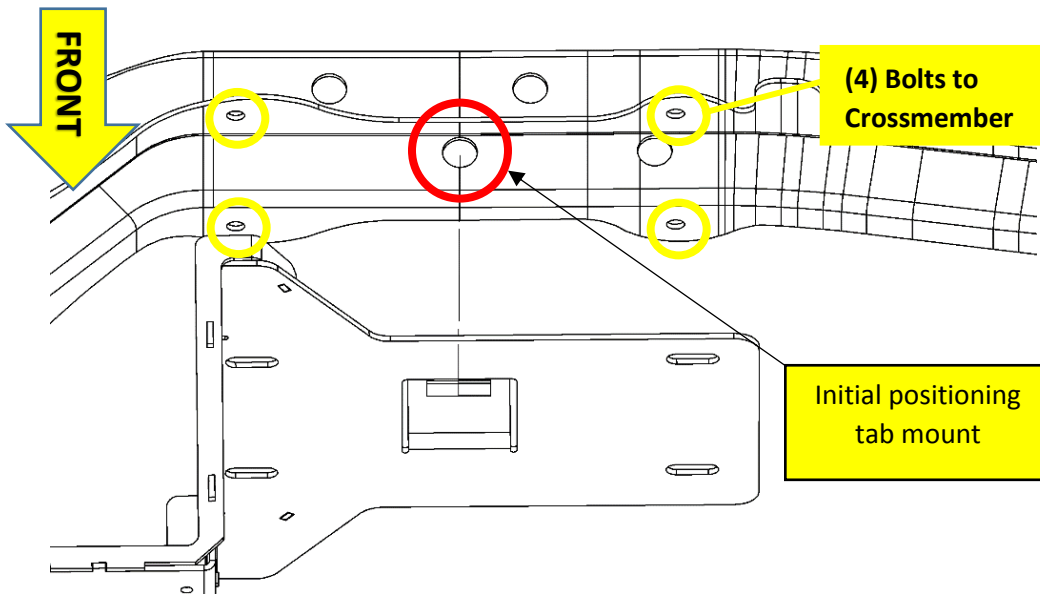

Figure 8 - EVAC Crossmember Mounting Points



Figure 9 - TUNDRA-301 and Air Compressor Mounted next to EVAC



TUNDRA-734/230

Installation and Operation Manual

- 10.2.6. Place Air Compressor onto Compressor Bracket (TUNDRA-101) and secure using M5 bolts, nuts and washers, as supplied inside Air Compressor box. Tighten all compressor feet bolts to 28-32 in-lbs, once desired compressor position is acquired. See Figure 11.
- 10.2.7. Route leader hose as shown in Figure 10; it MUST go through opening in Bracket and over Evaporative Canister in order to properly reach Air Tank Port, as shown in Figure 4 above.



Figure 10 - Compressor Leader Hose Routing

- 10.2.8. Adjust bracket position as necessary to obtain a minimum $\frac{1}{4}$ " clearance between bracket and fuel tank and $\frac{1}{8}$ " minimum between compressor and chassis. Hand tighten crossmember mount tab bolt.
- 10.2.9. Reinstall EVAC using OEM hardware and torque to factory spec (29 N*m / 21 ft-lbs). Final torque crossmember mount tab bolt to 18-21 ft-lbs.

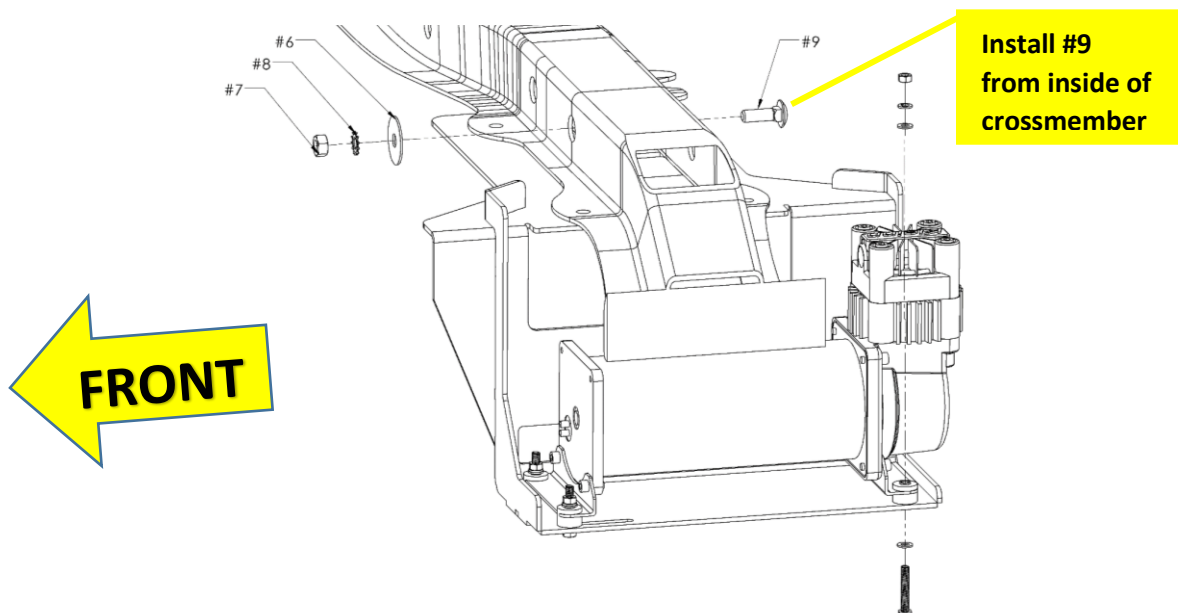

Figure 11 - TUNDRA-101 with Air Compressor and Hardware; Exploded View (6450RC Shown)

10.3. Horn Bracket (TUNDRA-301) Installation

10.3.1. Locate 2 holes on rear facing side of crossmember, as shown circled in Figure 12 below.

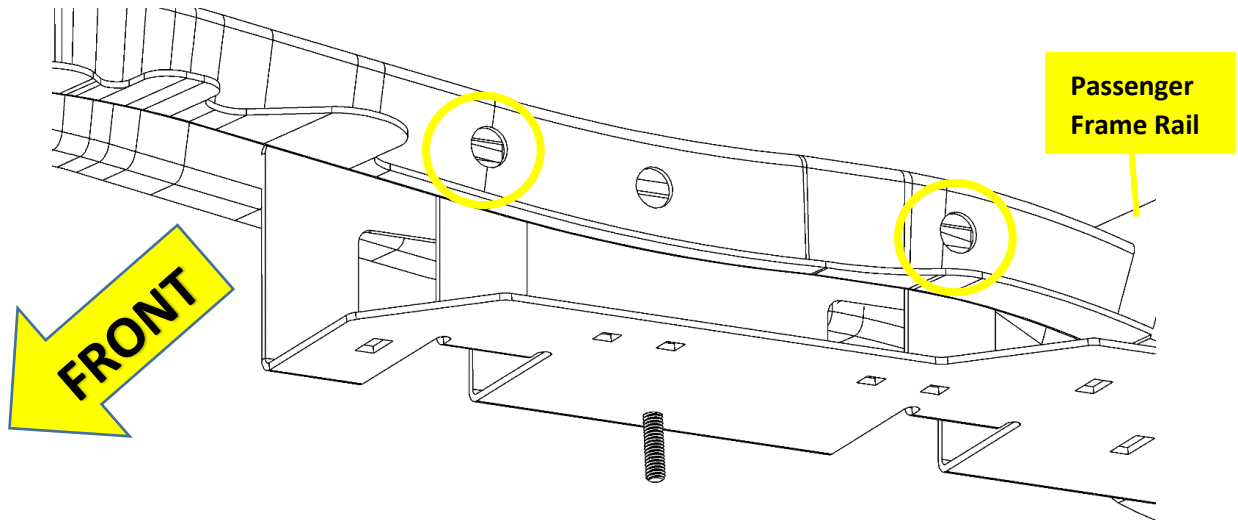

Figure 12 - TUNDRA-301 Mounting Locations

9.2.2 Lift TUNDRA-301 (Horn bracket) inside crossmember (there may be slight interference) and bolt through inside of crossmember using [hardware](#) #6, #7, #8, & #9, as shown circled in Figure 13 below. Hand tighten.

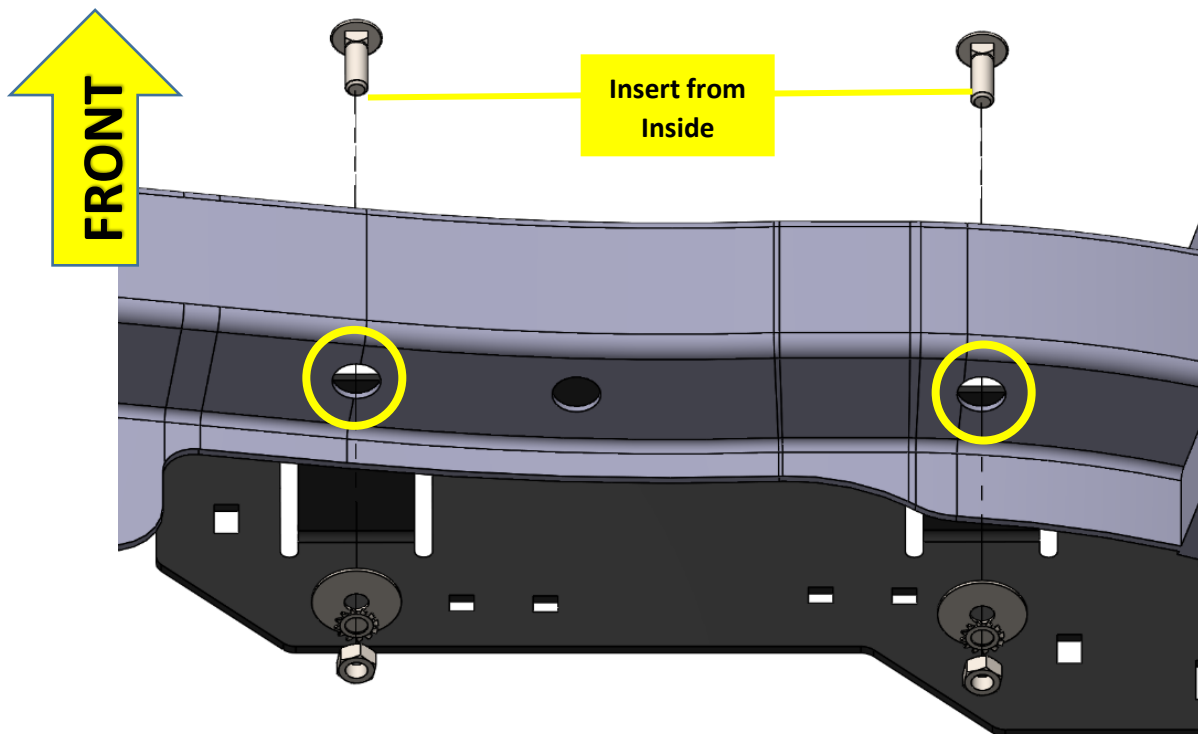

Figure 13 - TUNDRA-301 Mounting to Crossmember with Hardware; Exploded View

10.4. Air Tank and Bracket (TUNDRA-201) Installation

10.4.1. Lift Air Tank Bracket (Tundra-201) into position over Air Horn Bracket (TUNDRA-301) stud and front facing crossmember holes, as shown circled in Figure 14 below.

10.4.2. Using [hardware](#) #6, #8, & #11 mount assembly to crossmember; hand tighten.

10.4.3. Using [hardware](#) #5, #7, & #8 connect TUNDRA-201 to stud on Air Horn Bracket, as shown in Figure 15.

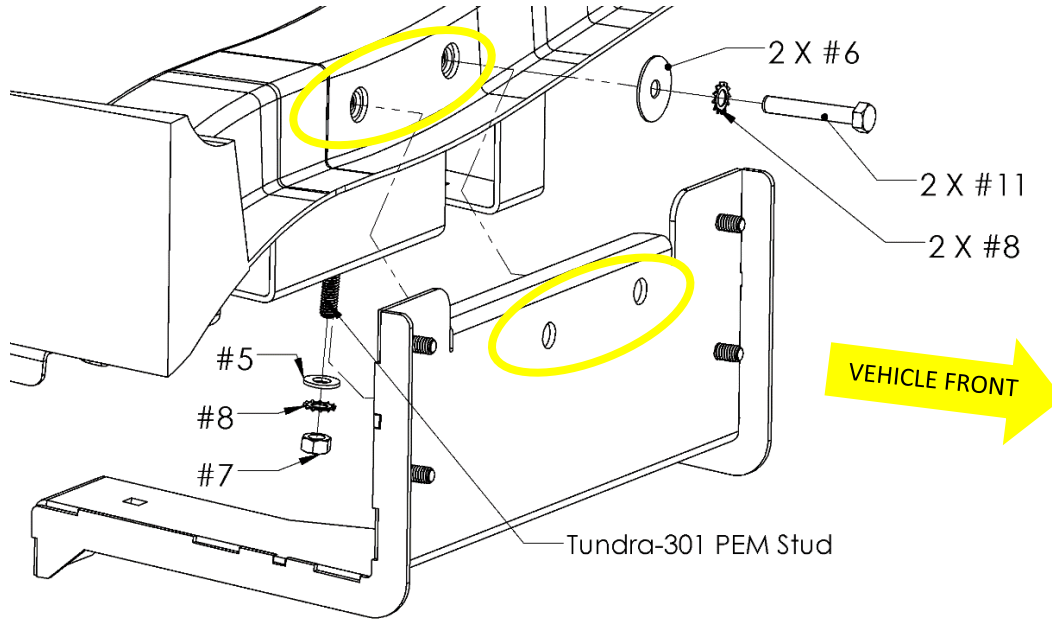

Figure 14 - TUNDRA-201 to TUNDRA-301 Mounting with Hardware; Exploded View

10.4.4. Connect TUNDRA-201 (Tank bracket) to TUNDRA-301 (Horn bracket) using [hardware](#) #5, #7, #8, & #9. See Figure 15 for hole positions.

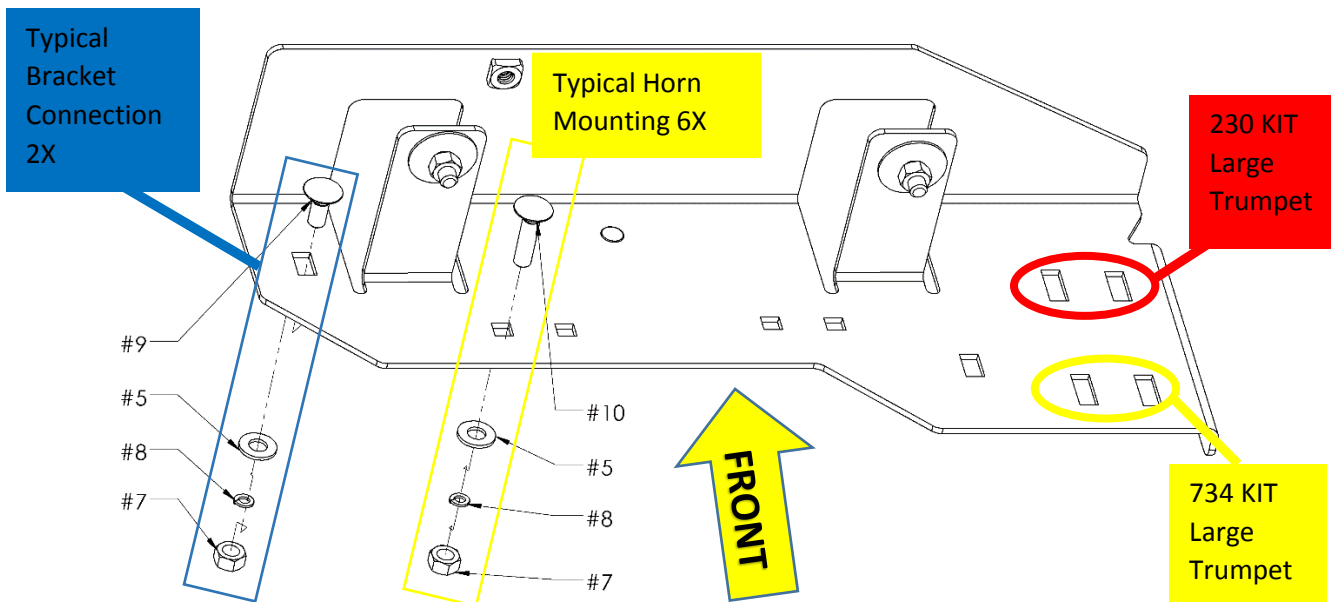

Figure 15 – TUNDRA-201 to TUNDRA-301 Hardware Connections; Exploded Views

10.4.5. Lift Air Tank into position onto Air Tank Bracket studs and attach with [hardware](#) #5, #7, & #8, as shown in Figure 16 below. Hand tighten.

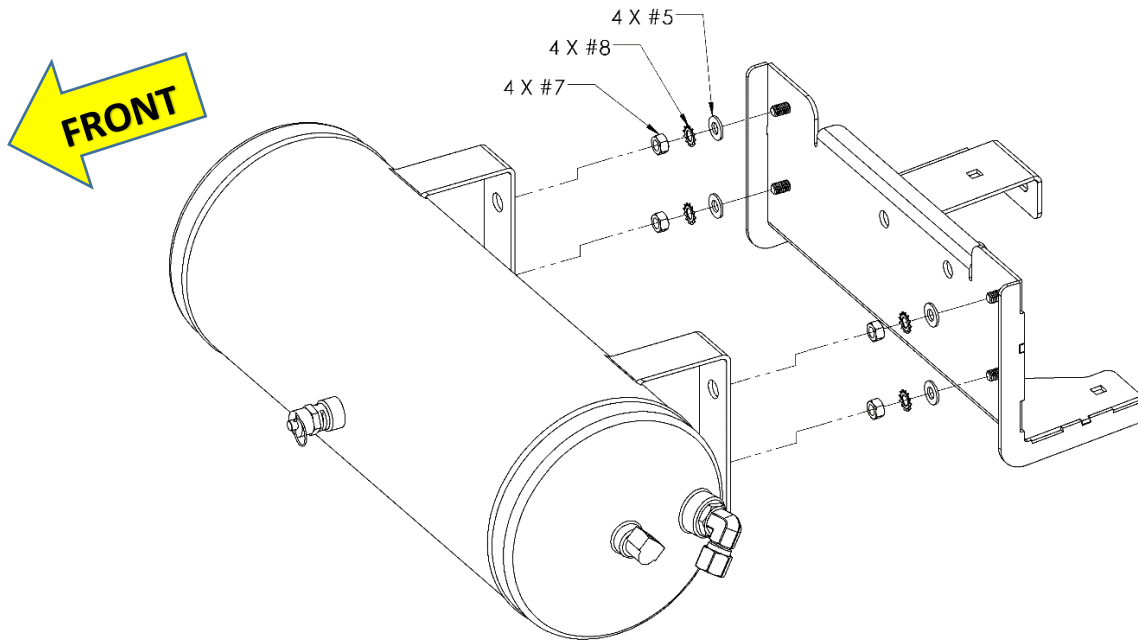

Figure 16 – Air Tank Installation onto TUNDRA-201; Exploded View

10.4.6. Position Air Tank and all Brackets as necessary to gain a minimum 1/4" clearance between Air Tank/Fittings and vehicle, then final tighten fasteners to 75-88 in-lbs in following order:

1. TUNDRA-201 to TUNDRA-301 connecting bolts
2. TUNDRA-201 crossmember mounting bolts (i.e., front side)
3. TUNDRA-301 crossmember mounting bolts (i.e., back side)
4. Air Tank mounting bolts

10.4.7. Attach leader hose from compressor to [Air Tank port](#), as shown in Figure 4 above. If necessary, readjust outlet fitting for horns to a 45 degree angle towards front of vehicle as shown in Figure 17 below.

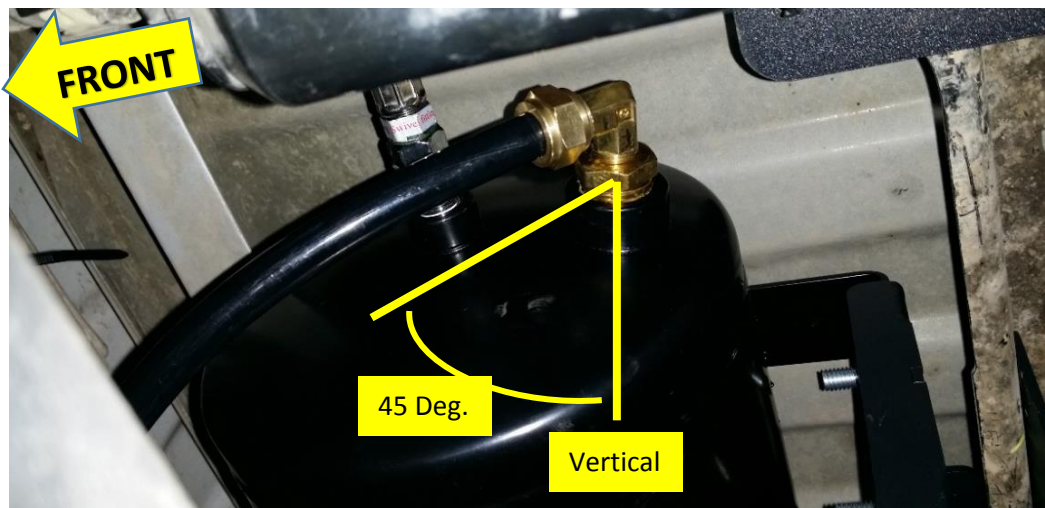

Figure 17 – Air Compressor Leader Hose to Air Tank Connection and Orientation

10.5. Air Tank Torque Strap (TUNDRA-202) Installation

- 10.5.1. Attach Tank Torque Strap (Tundra-202) to Tank Bracket (Tundra-201) using [hardware](#) #5, #7, #8, & #9; hand tighten.
- 10.5.2. Adjust positioning of first bolt as needed to use hardware #1, #2, #3, & #4 to attach other end of strap to frame rail; strap attaches below frame and has a washer above frame, as shown in Figure 18 & 19 below.
- 10.5.3. Once Strap is properly positioned tighten both bolts, as follows:
 - #4/#2 bolt/nut to 18-21 ft-lbs
 - #7 nut to 75-88 in-lbs

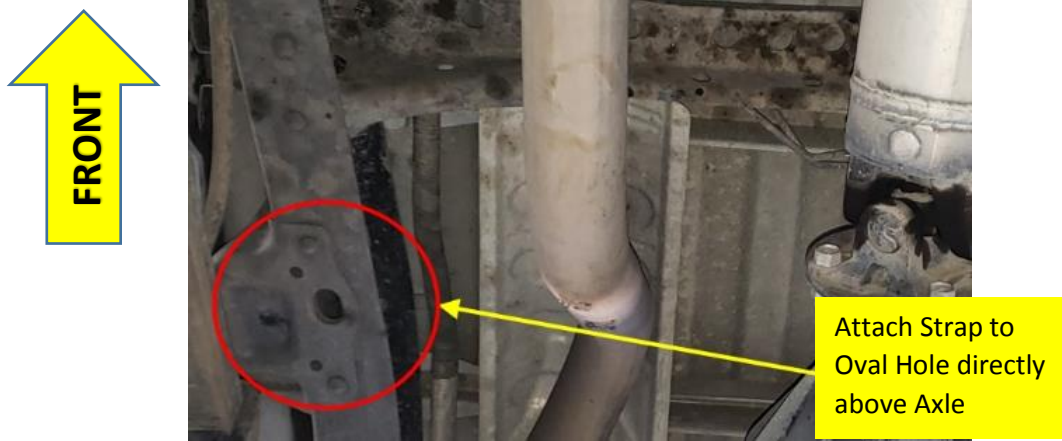

Figure 18 – Frame Mounting Hole for Air Tank Torque Strap

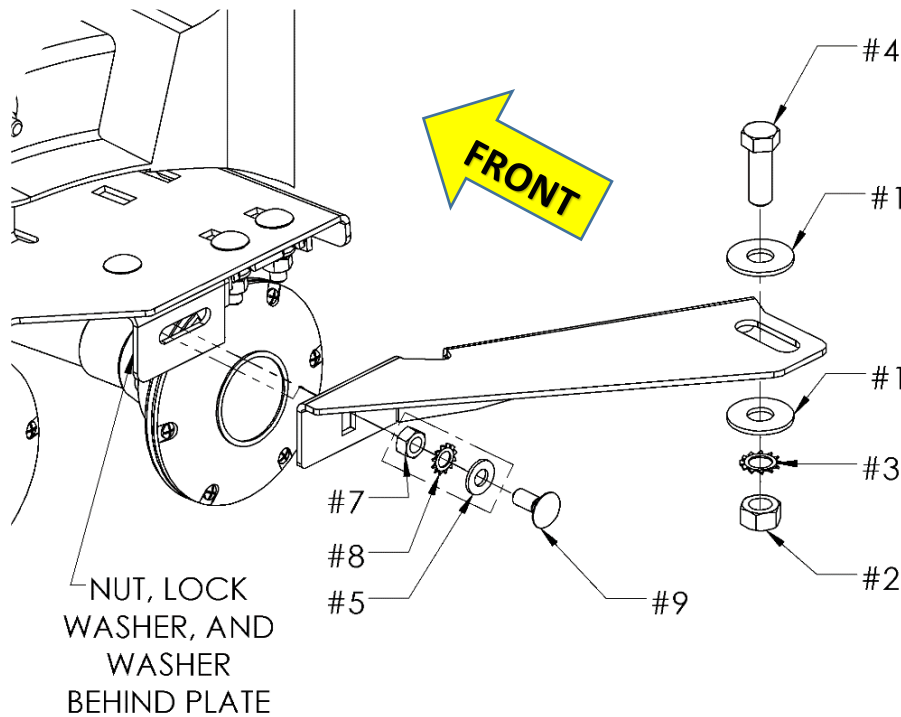

Figure 19 – Air Tank Torque Strap with Hardware; Exploded View

10.6. Connect Remote Quick Connect Kit to Vehicle

- 10.6.1. Route and attach Quick Connect Coupler Kit to vehicle, as desired using attachment bracket and self-drilling fasteners, supplied in Coupler package
- 10.6.2. Use supplied 1/4" tubing and attach to port shown in Figure 4 above.

Some optional locations include under hood, near grill, behind bumper, in bed rail, etc.



Figure 20 – Example of Air Coupler Mounted To Bumper

10.7. Trumpet and Air Horn Driver Installation

- 10.7.1. Remove and discard white plastic feet from drivers before install. See Figure 22.
- 10.7.2. Using [hardware](#) #5, #7, #8, & #10 mount Air Horn Drivers onto Horn Bracket (TUNDRA-301). Solenoid will be attached to Medium Air Horn Driver as shown circled in Figure 22 below; **ensure arrow on brass Solenoid is pointing toward Air Horn**. Hand tighten fasteners; see Figures 15 & 23 for reference.

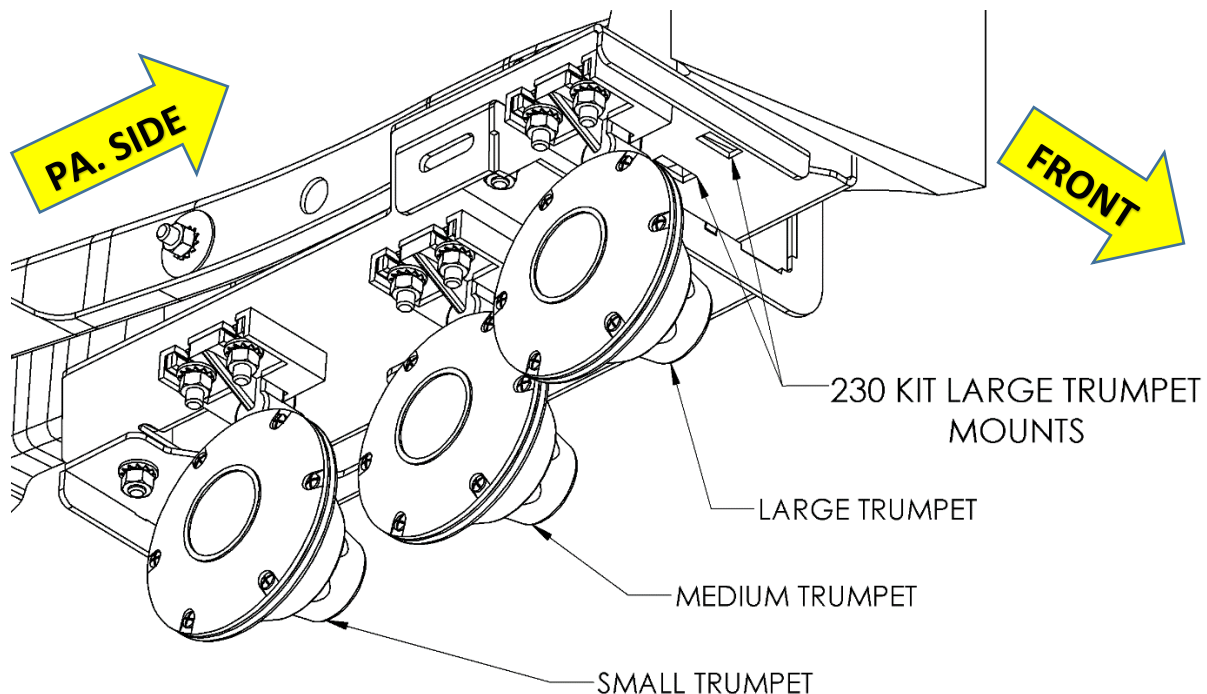

Figure 21 – Air Horn Driver Orientation and Mounting Location on Bracket



Figure 22 – Air Horn Drivers and Solenoid Mounted with Air Tubing Connected (730 Shown)

- 10.7.3. Connect Air Horns to each other and connect inlet line to [Air Tank port, as shown in Figure 4 above](#) using supplied semi-rigid plastic Air Tubing. Use supplied zip ties to secure Air Tubing to Brackets.
- 10.7.4. Re-attach Trumpets to Air Horn Drivers, in orientation shown in Figure 23 below. Tighten snugly using both hands to twist along bell end.
- 10.7.5. Position each Air Horn, as necessary to maintain at minimum ¼" between Trumpet, vehicle, Air Tank, and as far as possible from exhaust/muffler. Firmly tighten Air Horn mounting bolts to 75-88 in-lbs.
- 10.7.6. Using supplied plastic zip ties secure Air Tubing to Trumpets, as necessary to prevent abrasion.

NOTE: If parking brake cable contacts Large Trumpet, secure parking brake to Trumpet using zip tie(s).

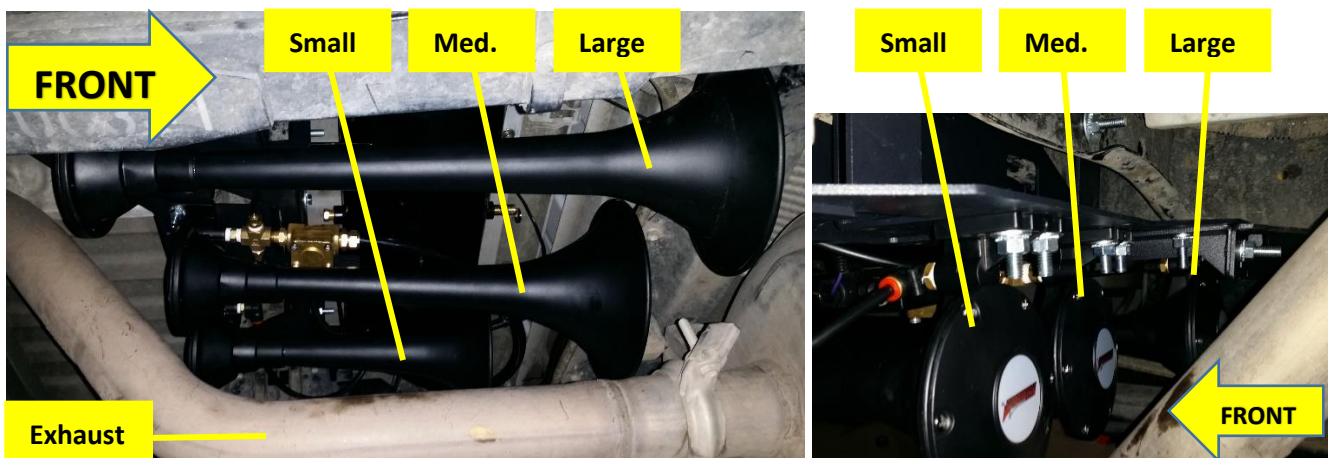

Figure 23 – Air Horn Drivers Final Install (730 Shown)

End of Section



TUNDRA-734/230

Installation and Operation Manual

11. Initial Testing of Kit

11.1. Reconnect Vehicle Battery(s)

CAUTION: Before connecting vehicle battery(s), verify all wiring is properly connected and no shorts exists. Use of Multi-Meter, or Test Light is recommended to check continuity of all connections.

11.2. Test Air Compressor

- 11.2.1. Turn vehicle ignition to on position and allow compressor to fill Air Tank. Initial fill may take approximately 1.5-3 minutes; Air Compressor should shut off automatically once full pressure is achieved.
- 11.2.2. If compressor runs excessively (i.e., 5 minutes or more), disconnect electrical power to Air Compressor and listen for air leaks in system. Repair any problems and retest; contact Kleinn technical support if problem persists.
- 11.2.3. Inspect all air line connections (i.e., Air Tank fittings, Quick Connect fittings, Air Horn fittings, etc.) for leaks by using a soap and water solution sprayed directly onto fittings
- 11.2.4. System must be pressurized or at least Air Compressor running
- 11.2.5. If an air leak is found:
- 11.2.6. Safely release air pressure from system (i.e., slowly open drain valve)
- 11.2.7. Disassemble leaky connection, re-seal and reinstall fittings as needed

11.3. Test Train Horns

- 11.3.1. Allow Air Compressor to run and shut-off automatically (i.e., Air Tank is full)
- 11.3.2. Verify all tubing and electrical wire is securely fastened to vehicle, brackets, or kit parts; if necessary, use extra zip ties to hold tubing and wire in place
- 11.3.3. Ensure all nearby persons have adequate hearing protection and provide courtesy warning to neighbors or others in vicinity

WARNING: NEVER operate train horns with ears close to trumpets or in an enclosed space without substantial hearing protection (i.e., > Ear Plugs and Ear Muffs) for all persons closer than 100 feet from vehicle. Never operate train horns outdoors when persons are near vehicle without adequate hearing protection.

- 11.3.4. Briefly activate Horns by pressing Horn Button for one (1) second; repeat three (3) times with a short rest period between (i.e., 1-3 seconds)
- 11.3.5. Horns should sound as expected and be loud; [click to listen to example 230 Kit](#)
- 11.3.6. Horn sound/loudness will taper quickly as Air Tank loses pressure
- 11.3.7. Allow Air Compressor to refill tank, if needed and activate Horns for longer three (3) second period to ensure Horns are functioning properly.

11.4. Test Quick Connect Coupler

- 11.4.1. Allow Air Compressor to refill tank, if needed
- 11.4.2. Attach supplied INF-1 inflator kit to Quick Connect Coupler and verify adequate air pressure is available
- 11.4.3. Test fill tires on vehicle, bicycle, etc.
- 11.4.4. Use Air Blow Gun
- 11.4.5. Use Air Impact Gun

End of Section



TUNDRA-734/230

Installation and Operation Manual

12. General Operation of Kit

12.1. Compressor Operation

WARNING: *Never operate Air Compressor above its MAXIMUM PRESSURE RATING (see label on body). Operation exceeding maximum pressure will damage Air Compressor and may result in Dangerous Air System failure.*

- 12.1.1. Air compressor is equipped with an automatic thermal overload protection circuit, designed to protect air compressor from overheating and causing permanent damage.
- 12.1.2. Automatic thermal overload protector will automatically reset after 30 minutes.
- 12.1.3. To prevent discharge of vehicle's battery and for best performance, keep vehicle's engine running while using air compressor for any prolonged use (i.e., filling tires, using air tools, etc.).

12.2. Horn Operation

- 12.2.1. Allow Air Compressor to run until it shuts off automatically (i.e., Air Tank is full), or for at least one minute in between horn activations.
- 12.2.2. Press Horn Button to activate Horns
- 12.2.3. Horn sound/loudness will taper quickly as Air Tank loses pressure.
- 12.2.4. Horns should sound for 3-7 seconds depending on kit and tank size

WARNING: *NEVER operate train horns with ears close to trumpets or in an enclosed space without substantial hearing protection (i.e., > Ear Plugs and Ear Muffs) for all persons closer than 100 feet from vehicle. Never operate train horns outdoors when persons are near vehicle without adequate hearing protection.*

13. Routine Maintenance

Perform following steps at least once during recommended intervals.

- 13.1. Yearly, or every 12000 miles verify all mounting fasteners are properly torqued; applying witness marks across fasteners and mounting parts is good practice to quickly ensure fasteners have not moved.
- 13.2. Yearly, or every 12000 miles inspect parking brake cable where it may rub large trumpet, to verify no abrasion or rubbing.
- 13.3. Yearly, or every 12000 miles remove all road grime and mud from mounting brackets and kit parts using clean water from a garden hose; pay special attention to corners where dirt may collect. Touch up all paint chips using automotive grade enamel in either spray, or brush form.

NOTE: High-pressure washers may damage part finishes and *must* be used with care. Do this more frequently if traveling regularly off-road, or in winter climates where road salts are used.

- 13.4. Yearly, or every 12000 miles check electrical and air fitting connections and wires for abrasion, corrosion, or other damage. Replace damaged components.

NOTE: if system runs continuously or turns on unexpectedly, leaks or intermittent electrical connection may be present.

- 13.5. Monthly, or every 10 hours of compressor run time, drain moisture from air tank using drain valve installed at bottom of tank.

WARNING: *Failure to regularly drain air tank may result in corrosion inside tank and possible failure in tank or air lines, which can suddenly release air pressure causing injury to nearby people.*

- 13.6. Yearly, or every 12000 miles clean, or replace air compressor air filter element. Replacement frequency depends on operating frequency and conditions of operating environment (i.e., daily use of air compressor in dusty, or wet environment requires more frequent filter change).