



---

# SDKIT17-230/734STD INSTALLATION MANUAL

REV: BETA (4/13/2020)

---

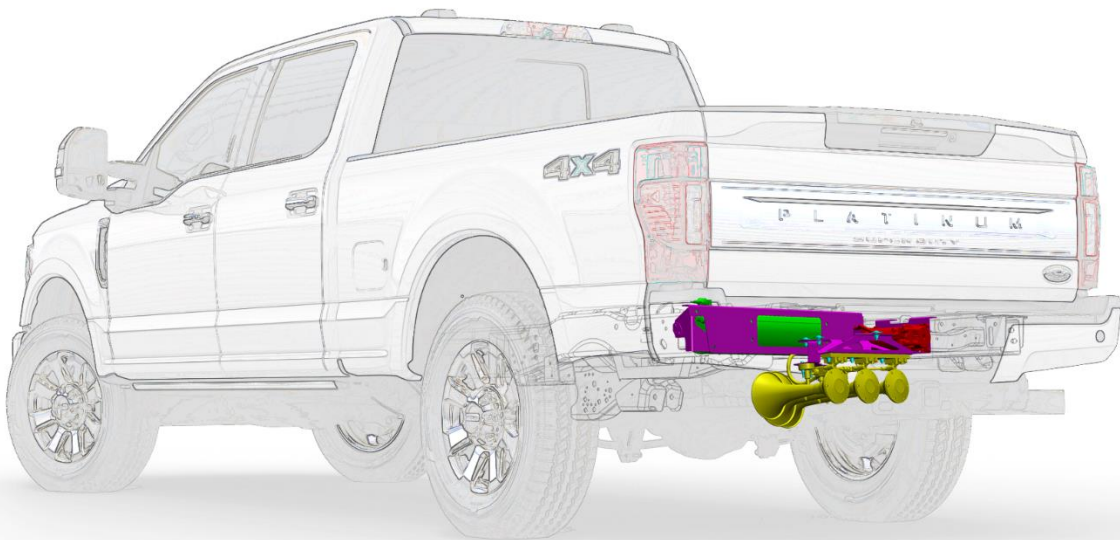

© Kleinn Air Horns 2020, All rights reserved.



# SDKIT17-230/734STD

## Installation and Operation Manual

**This digital PDF is interactive.**

**Please save ink and paper...**





# SDKIT17-230/734STD

## Installation and Operation Manual

### Table of Contents

1.	LIST OF FIGURES .....	5
2.	How to Use this Manual .....	6
2.1.	Interactive Manual using Adobe Reader .....	6
2.2.	Your Kit SKU Number and this Manual.....	6
2.3.	Illustration/Photo Details and Orientation.....	6
3.	Safety First.....	7
4.	Application Chart.....	8
4.1.	Bolt-On Vehicle List .....	8
4.2.	**Excluded Vehicles .....	8
4.3.	Aftermarket Product Compatibility .....	8
5.	Installation Overview.....	9
5.1.	Kit Layout and System Location(s).....	9
5.2.	Install Process Outline.....	11
5.3.	Approximate Installation Time .....	11
6.	List of Tools and Supplies .....	12
6.1.	Standard Tool List (Required).....	12
6.2.	Special Tool List (Recommended) .....	12
6.3.	Shop Consumables List (Recommended) .....	12
7.	Parts List .....	13
7.1.	Before Starting, Review Parts List .....	13
7.2.	Pre-Packaged Electro-Mechanical Kit Items.....	13
7.3.	Air Fittings and Related Items .....	14
7.4.	Electrical Small Components and Related Items.....	15
7.5.	Bolt-On Mounting Brackets & Special Hardware .....	15
7.6.	Hardware, Fasteners and Soft Parts.....	16
7.7.	Add-On Accessories.....	16
8.	Bench Assembly.....	17
8.1.	Disassemble Trumpets from Air Horn Drivers.....	17
9.	On-Vehicle Mechanical Assembly .....	18
9.1.	Remove Spare Tire Lift Mechanism.....	18
9.2.	Install Air Horn Bracket (SD17-304).....	20
9.3.	Install Air Horn Ore Support Bracket (SD17-306) – 734STD ONLY .....	21



# SDKIT17-230/734STD

## Installation and Operation Manual

9.4. Install Air Horn Sub-Assembly .....	22
9.5. Install Air Tank Fittings on Air Tank & Connect Air Tubing.....	23
9.6. Final Trumpet Installation .....	24
10. On-Vehicle Electrical Installation.....	25
10.1. Relay and Fuse Diagram for Air Horn System.....	25
10.2. Suggested Wire Routing for Air Horn System .....	26
10.3. Disconnect Vehicle Battery(s).....	26
10.4. Connect Wiring to Fuse and Relay.....	26
10.5. Install Horn Button .....	27
10.6. Connect Pressure Switch .....	27
10.7. Connect Air Compressor.....	27
10.8. Connect Air Horn Solenoid(s) .....	27
10.9. Secure Wiring to Vehicle .....	27
11. Final Steps & Testing .....	28
11.1. Reconnect Vehicle Battery(s) .....	28
11.2. Test Air Compressor .....	28
11.3. Test Train Horns.....	28
11.4. Test Quick Connect Coupler .....	28
12. General Operation.....	29
12.1. Compressor Operation .....	29
12.2. Horn Operation.....	29
13. Routine Maintenance.....	29

End of Table of Contents



# SDKIT17-230/734STD

## Installation and Operation Manual

### 1. LIST OF FIGURES

Figure 1 – Above Vehicle View Showing Kit Layout (2020 F-350 Crew Cab Short Bed Shown) .....	9
Figure 2 – Under Vehicle View of Air Horn Installed – without Air Tank & Compressor (2017 F-250 Shown) .....	10
Figure 3 – Removing Trumpets from Air Horn Drivers, Exploded View .....	17
Figure 4 – Exploded view of Spare Tire Mechanism from Ford Parts (2017 F-250/F-350 shown).....	18
Figure 5 – Underbody view of Spare Tire Mechanism and Crossmember (2017 F-250 shown).....	19
Figure 6 – Underbody view of Crossmember with Mounting Holes and Bolts installed (2017 F-250 shown) .....	20
Figure 7 – Installing SD17-304 Bracket (Exploded view shown).....	20
Figure 8 – Installing Horn Ore Support Bracket SD17-306 (Exploded view shown) – 734STD ONLY .....	21
Figure 9 – Air Horn Sub-Assembly installation (Exploded View of 730 Horn with Ore Supports shown).....	22
Figure 10 – Installing Air Fittings onto Air Tank (Exploded view shown as if installed in Vehicle).....	23
Figure 11 – Re-attaching Trumpets (Exploded View shown as if installed in vehicle) .....	24
Figure 12 – Suggested Ignition Relay Diagram for Air Horn System (230/730 Horn Shown).....	25
Figure 13 – Suggested Wire Routing for Horn, Air Compressor, and Pressure Switch (SDKIT17-734STD Shown) .	26
Figure 14 – Relay and Fuse location example under hood (Shown in example vehicles).....	26
Figure 15 – Horn Button Installed in Dash and OE Upfitter Switches (Shown in example vehicles) .....	27

End of Figures



# SDKIT17-230/734STD

## Installation and Operation Manual

## 2. How to Use this Manual

### 2.1. Interactive Manual using Adobe Reader

It is recommended to open this digital PDF using Adobe Reader<sup>®</sup> to take advantage of following key features:

- **Hyperlinks** ([blue underlined text](#)) allow access to additional content via internet; click/tap to activate
  - Includes [Installation Figures](#) and "[Figure xx](#)"
- **Table of Contents** page allows easily navigating this manual; click/tap any section line to go to it
- **Bookmarks** allow quickly navigating to any section; click/tap
- **Zoom IN** on pictures by pressing "CTRL and +" at same time on PC, or pinch in on smart devices
- **Zoom OUT** on pictures by pressing "CTRL and -" at same time on PC, or pinch out on smart devices

---

### To install Adobe Reader<sup>®</sup>

On PC, or Mac

- visit [adobe](#)

On Android, iPhone/iPad, and Windows devices,

- visit [acrobat.adobe](#)
- 

### 2.2. Your Kit SKU Number and this Manual

This manual covers installation, testing, and operation of following SKU part numbers

2.2.1. **SDKIT17-230STD** (i.e., 230 Train Horn)

2.2.2. **SDKIT17-734STD** (i.e., 730 Train Horn)

NOTE: Illustrations and pictures contained herein may represent only one kit part number. Where critical differences exist between kits (i.e., different parts, orientation, mounting points, etc.), additional text, or necessary graphics are provided to minimize confusion.

Parts list explicitly state kit differences with **(BOLD TEXT)** inside parenthesis, shown below part number.

### 2.3. Illustration/Photo Details and Orientation

This manual may use digitally created illustrations, and/or actual photos of example vehicle. These graphics may not include exact items found on your vehicle (i.e., electrical wiring, fuel lines, body panels, etc.). Illustrations typically will be missing details and are for clarity to show critical mounting locations and orientation on vehicle.



Throughout manual yellow arrows with text reading "FRONT", may be present over illustrations and pictures. These arrows specify direction toward front of vehicle and provide clarity to how illustration is viewed.

End of Section



# SDKIT17-230/734STD

## Installation and Operation Manual

### 3. Safety First

Read manual thoroughly before starting installation of this kit. Verify you have all parts listed and that you clearly understand this installation procedure. Contact Kleinn technical support for any questions.

Installation of this kit requires **moderate mechanical aptitude**; seek professional help if you're not competent using hand tools in tight uncomfortable spaces, and around possibly rusted and sharp vehicle parts.

Before starting, obtain proper tools required to perform installation correctly, adequate lighting, eye protection, hearing protection for operating train horns, and hand protection to guard against sharp edges and metal burrs, which may be present on kit parts and vehicle parts.

Throughout this manual the following words may be used; be aware of their meaning and application.

**CAUTION:** means damage could occur to vehicle, or kit parts during, or after installation

**WARNING:** means injury could occur to you or others, including damage to vehicle, or kit parts

**DANGER:** means serious injury or death could occur to you or others during installation

End of Section



# SDKIT17-230/734STD

## Installation and Operation Manual

### 4. Application Chart

#### 4.1. Bolt-On Vehicle List

SDKIT17-230/734STD is a direct bolt-on aftermarket product for FORD vehicles listed in below chart; every effort has been made to verify correct fitment on these vehicles in their factory, non-modified conditions.

MODEL YR	MODEL	DRIVE	ENGINE	BODY	TRIM
2017-2020	F-250 SUPER DUTY	ALL	ALL	ALL	ALL**
2017-2020	F-350 SUPER DUTY	ALL	ALL	ALL	ALL**

NOTE: All vehicles listed may require drilling holes for ground wires and installing switches, based on preference of installed switch locations and wire grounding points.

#### 4.2. \*\*Excluded Vehicles

4.2.1. N/A

#### 4.3. Aftermarket Product Compatibility

4.3.1. This kit has been designed to be compatible with following products from leading manufacturers:

- Most aftermarket suspension systems that directly-bolt on (i.e., utilize OE mounting points)
- Aftermarket power steps and rocker steps/running boards
- Aftermarket front bumpers
- Aftermarket rear bumpers

4.3.2. **This kit has NOT been designed** to be compatible with any of the following products:

- Any aftermarket product that occupies space where Spare Tire resides
- Aftermarket exhaust systems

NOTE: Review this manual in full before unpacking items and verify correct space and mounting locations exist with your aftermarket product(s). *To install this kit alongside your other aftermarket product(s), modification to included parts, your vehicle, or aftermarket product(s) may be required.*

End of Section





# SDKIT17-230/734STD

## Installation and Operation Manual

### 5. Installation Overview

#### 5.1. Kit Layout and System Location(s)

SDKIT17-230/734STD consists of following components, located on vehicle, as follows:

ITEM	DESCRIPTION	VEHICLE LOCATION	MOUNTING METHOD	APPROX. INSTALL TIME
1	6450RC Air Compressor ***OBA Kit	Underbody, Passenger Side (near Spare Tire)	Bracket bolts to Frame rail	2-4 Hours
2	3.0 Gal. Air Tank ***OBA Kit	Underbody, Driver Side (behind Rear Axle)	Bracket bolts to both Frame Rails	2-4 Hours
3	230/730 Series Triple Horn with Air Solenoids	In place of Spare Tire (in front of rear Bumper)	Bracket bolts to Frame Crossmember	1-2 Hours

**NOTE:** Kleinn SD17OBA-6450 is required to be installed before, or along side this kit. Click below link to visit Kleinn’s website, including downloading instructions.

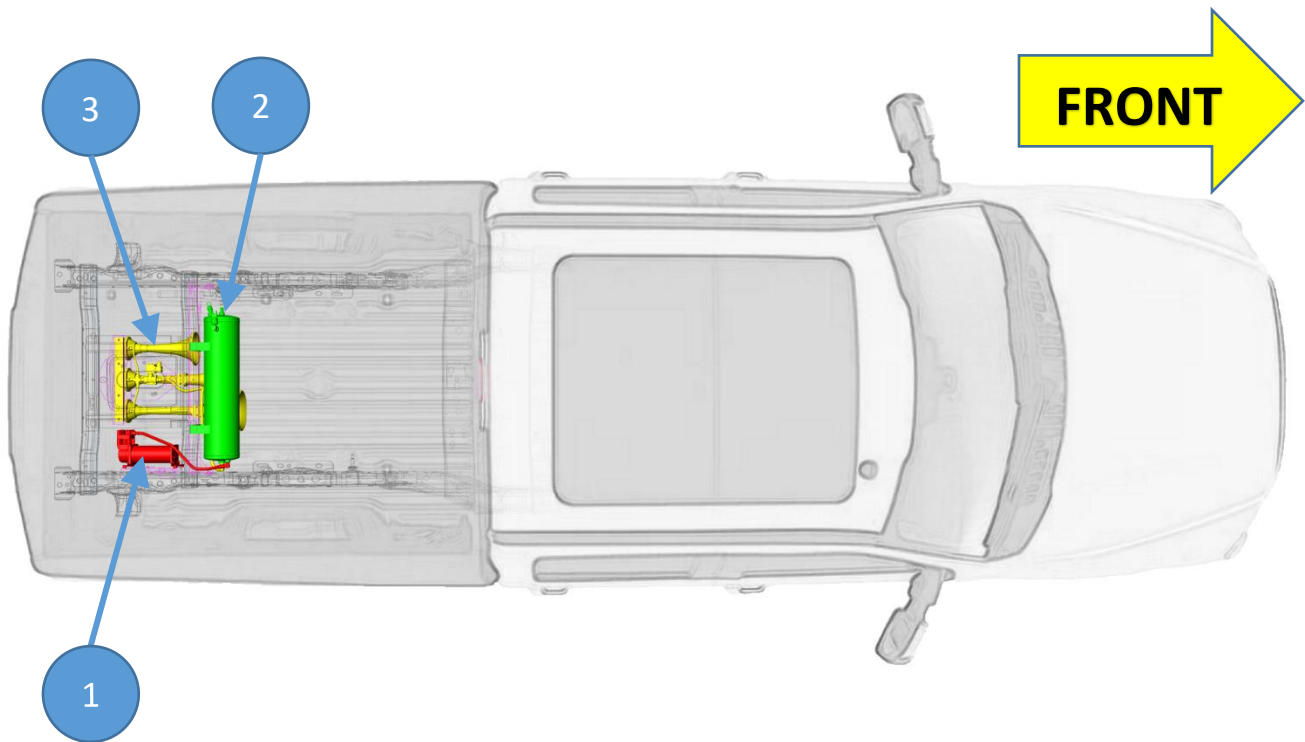

Figure 1 – Above Vehicle View Showing Kit Layout (2020 F-350 Crew Cab Short Bed Shown)



# SDKIT17-230/734STD

## Installation and Operation Manual



*Figure 2 – Under Vehicle View of Air Horn Installed – without Air Tank & Compressor (2017 F-250 Shown)*



# SDKIT17-230/734STD

## Installation and Operation Manual

### 5.2. Install Process Outline

For person(s) with prior experience installing SDKIT17-230/734STD, a reminder of install steps are listed below:

#### UNPACKAGE KIT (SECTION 7)

1. Layout and organize all parts on bench

#### BENCH ASSEMBLY (SECTION 8)

2. Remove Air Horn Trumpets from Air Horn sub-assembly

#### ON-VEHICLE, MECHANICAL (SECTION 9)

3. **Install SD17OBA-6450; reference SDKIT17-230/734 Installation & Operation manual**
4. Remove Spare Lift Mechanism
5. Install Air Horn Bracket (SD17-304)
6. Install Air Horn Ore Support Bracket (SD17-306) – 734STD ONLY
7. Install Air Horn Sub-Assembly
8. Install Air Fittings on Air Tank; *if SD17OBA-6450 is NOT already installed, assemble new Air Fittings to Air Tank during Bench Assembly*
9. Connect Air Tubing to Air Tank and Electrical Wiring

#### ON-VEHICLE, ELECTRICAL (SECTION 10)

10. Install Relay & Fuse, route Wiring, and install Horn Button
11. Connect all Electrical items (Air Horn, Pressure Switch, Air Compressor)

#### FINAL STEPS (SECTION 11)

12. Install Trumpets onto Air Horn Drivers & Final Tighten Air Horns
13. Test system and adjust, as needed

### 5.3. Approximate Installation Time

**SDKIT17-230/734STD is a multi-faceted product consisting of mechanical, electrical, and pneumatic components.**

For a typical home mechanic, auto enthusiast, or technician installing this kit for first time, a professional installation job with setup and testing of final product, is estimated to take:

- **6-12 Hours**

---

End of Section



# SDKIT17-230/734STD

## Installation and Operation Manual

### 6. List of Tools and Supplies

#### 6.1. Standard Tool List (Required)

- 6.1.1. Basic mechanic's 3/8" drive socket sets with extensions
  - Inch Size Sockets (1/4" – 1" Hex)
  - Metric Size Sockets (6mm – 20mm Hex)
- 6.1.2. Basic mechanic's combination wrenches (box/open-end)
  - Inch Size Wrenches (1/4" – 1" Hex)
  - Metric Size Wrenches (6mm – 20mm Hex)
- 6.1.3. Basic mechanic's screwdriver set (Philips, Flat Head)
- 6.1.4. Diagonal Cutter/Wire Cutter Pliers
- 6.1.5. Wire Strippers
- 6.1.6. Wire Terminal Crimpers
- 6.1.7. Slip-Joint Pliers
- 6.1.8. Vise Grips, or Locking Pliers
- 6.1.9. Small pry bar, or large flat blade screwdriver
- 6.1.10. Utility Knife, or Utility Razor blade
- 6.1.11. Magnetic retrieval tool

#### 6.2. Special Tool List (Recommended)

- 6.2.1. Power Hand Grinder, Air Grinder with Cut-Off wheel, or Hacksaw
- 6.2.2. 10-100 ft-lbs. torque wrench
- 6.2.3. 20-150 in-lbs. torque wrench
- 6.2.4. Multi-Meter for 12V DC electrical systems, or equivalent
- 6.2.5. 12V DC Test Light, or equivalent
- 6.2.6. Trim Panel Tool, for removing wiring and body clips, when needed

#### 6.3. Shop Consumables List (Recommended)

- 6.3.1. Quality Electrical tape
- 6.3.2. Di-electric grease for electrical connections
- 6.3.3. Heat Shrink tubing for electrical connections
- 6.3.4. Medium-Strength ThreadLocker (i.e., Blue Loctite® PN 242), or equivalent
- 6.3.5. Low-Strength ThreadLocker (i.e., Purple Loctite® PN 222), or equivalent
- 6.3.6. Black/Clear Silicone for drilling holes in body
- 6.3.7. Sand Paper, or Wire Brushes for installing ground wires
- 6.3.8. Extra plastic zip ties > 6" long
- 6.3.9. Extra NPT sealant (i.e., Kleinn Air Horn Juice, Teflon tape, etc.)
- 6.3.10. Touch-up paint for frame/chassis/body (i.e., primer or black epoxy)
- 6.3.11. Typical cleanup supplies

End of Section



# SDKIT17-230/734STD

## Installation and Operation Manual

### 7. Parts List



#### 7.1. Before Starting, Review Parts List

Unpackage and organize Kit across a large work area and verify all parts are included, as listed below. Contact Kleinn support if any questions arise.

- 7.1.1. Review pre-packaged Kit items (i.e., K1, K2, etc.)
- 7.1.2. Review Air Fittings and Tubing (i.e., F1, F2, etc.)
- 7.1.3. Review Wiring and Accessories (i.e., E1, E2, etc.)
- 7.1.4. Review Bolt-On Mounting Brackets (i.e., M1, M2, etc.)
- 7.1.5. Review Hardware/Fasteners (i.e., H1, H2, etc.)
- 7.1.6. Review Add-On Accessories (i.e., X1, X2, etc.)
- 7.1.7. Familiarize yourself with how parts assemble

#### 7.2. Pre-Packaged Electro-Mechanical Kit Items

NOTE: Items in this section come in their own packages and may include additional items inside package

ITEM	QTY	PART NUMBER	DESCRIPTION	PICTURE
K1	1	SD17OBA-6450	Includes Air Compressor, Air Tank, Brackets, Hardware, Electrical, etc.	
K2	1	730 <b>(734STD ONLY)</b>	730 Series Horn Kit, with included solenoid/valve, and 1/2" Air Tubing, 20 ft. long	
K2	1	230 <b>(230STD ONLY)</b>	230 Series Horn Kit, with included solenoid/valve, and 1/4" Air Tubing, 20 ft. long	



# SDKIT17-230/734STD

## Installation and Operation Manual

### 7.3. Air Fittings and Related Items

ITEM	QTY	PART NUMBER	DESCRIPTION	PICTURE
F1	1	51238L	3/8" NPT X 1/2" Compression Fitting, 90 Deg Elbow	
F2	1	53814R (230STD ONLY)	3/8" NPT FEMALE X 1/4" NPT Reducer Fitting	
F3	2	51414L (230STD ONLY)	1/4" NPT X 1/4" TUBE FITTING, MALE 90 DEG. ELBOW	
F4	1	KLEINN AIR HORN JUICE	THREAD SEALANT FOR NPT FITTINGS	



# SDKIT17-230/734STD

## Installation and Operation Manual

### 7.4. Electrical Small Components and Related Items

ITEM	QTY	PART NUMBER	DESCRIPTION	PICTURE
E1	1	SD17-STD WIRE KIT	ELECTRICAL WIRE, CONNECTORS, AND ZIPTIES <ul style="list-style-type: none"> <li>• PURPLE (18 GA.) – 20 FT</li> <li>• BLACK (12 GA.) – 2 FT</li> </ul>	
E2	1	SD17-STD LOOM PACK	WIRE LOOM, CORRUGATED AND SPLIT <ul style="list-style-type: none"> <li>• 1/8" X 20 FT</li> <li>• 1/4" X 5FT</li> <li>• 1/2" X 5FT</li> </ul>	
E3	1	320	TERMINATOR – NICKEL PLATED REMOTE HORN BUTTON	

### 7.5. Bolt-On Mounting Brackets & Special Hardware

ITEM	QTY	PART NUMBER	DESCRIPTION	PICTURE
M1	1	SD17-304	SPARE TIRE HORN BRACKET, CUT & FORMED	
M2	2	SD17-306 (734STD ONLY)	DUAL TRUMPET SUPPORT BRACKET, CUT & FORMED	







# SDKIT17-230/734STD

## Installation and Operation Manual

### 7.6. Hardware, Fasteners and Soft Parts

NOTE: Pictures only indicative, not to scale and may not represent exact item

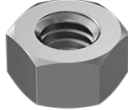
ITEM	QTY.	DESCRIPTION	WHERE USED	PICTURE
H1	4	(5/16"-18 X 1.00" LONG) RIBBED NECK CARRIAGE BOLT, GRADE 2, ZINC-PLATED	HORN BRACKET MOUNTING (4)	
H2	12	(5/16" ID X 1.5" OD) FLAT WASHER, FENDER, ZINC- PLATED	HORN BRACKET MOUNTING (12)	
H3	4	(5/16" ID X 0.88" OD) FLAT WASHER, USS, ZINC- PLATED	HORN BRACKET MOUNTING (4)	
H3	4	(5/16") LOCK WASHER, SPLIT, ZINC- PLATED	HORN BRACKET MOUNTING (4)	
H4	4	(5/16"-18) HEX NUT, GRADE 2, ZINC- PLATED	HORN BRACKET MOUNTING (4)	

### 7.7. Add-On Accessories

ITEM	QTY	PART NUMBER	DESCRIPTION	PICTURE
X1	-	-	-	

End of Section





# SDKIT17-230/734STD

## Installation and Operation Manual

### 8. Bench Assembly

Complete following steps off vehicle to facilitate final installation.

#### 8.1. Disassemble Trumpets from Air Horn Drivers

**NOTE:** This step is performed to facilitate installation on Vehicle of Air Horn sub-assembly, specifically in connecting Air Tubing, Wiring, and Horn Ore Supports (734STD only). It also enables installer to choose orientation of small, medium, large Trumpets when re-installing them (i.e. order from left to right).

*This step may be omitted if desired, especially on 230STD.*

- 8.1.1. Remove Air Horn sub-assembly from packaging; Air Tubing and Hardware will be used later.
- 8.1.2. Disassemble Trumpets from Air Horn Drivers by firmly grasping Trumpet around Metal/Chrome Collar and twisting counter-clockwise, as shown below. If necessary, use pliers with rag or soft material over jaw.
- 8.1.3. If necessary, clamp sub-assembly to a bench or place in a Vise using soft jaws to facilitate removing Trumpets

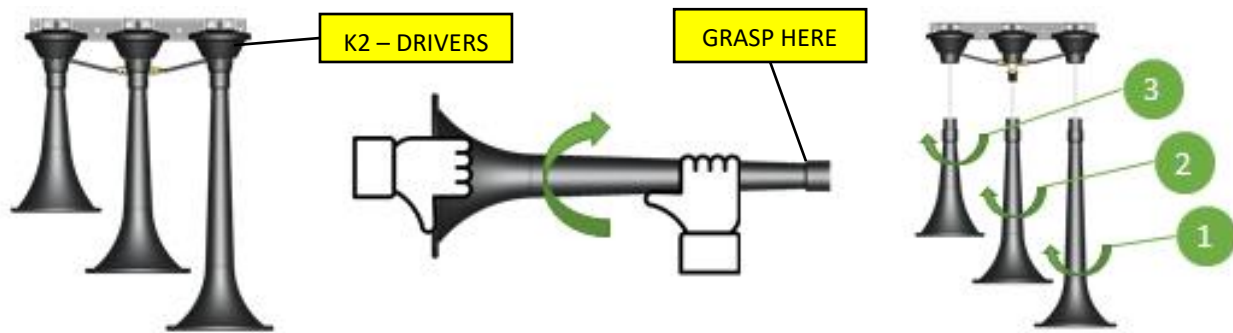

Figure 3 – Removing Trumpets from Air Horn Drivers, Exploded View

### 9. On-Vehicle Mechanical Assembly

Complete following steps on-vehicle using a lift, vehicle ramps, or other safe lifting method.

**DANGER:** Follows all manufacturer's instructions for safely lifting vehicle; reference owner's manual.

#### 9.1. Remove Spare Tire Lift Mechanism

- 9.1.1. Remove Spare Tire cable lock from Frame (see "1A381" in below image).
- 9.1.2. Locate Plastic Guide Tube going into Spare Tire Lift Mechanism body (see "1A433" in below image).
- 9.1.3. Using pry bars or large flat blade screwdrivers, expand end of tube and pull to remove rearward.

**NOTE:** to completely remove plastic tube from vehicle, it may be required to remove rear bumper, or use a saw to cut tube and remove in multiple pieces. Otherwise, secure in place with Zip Ties, or similar.

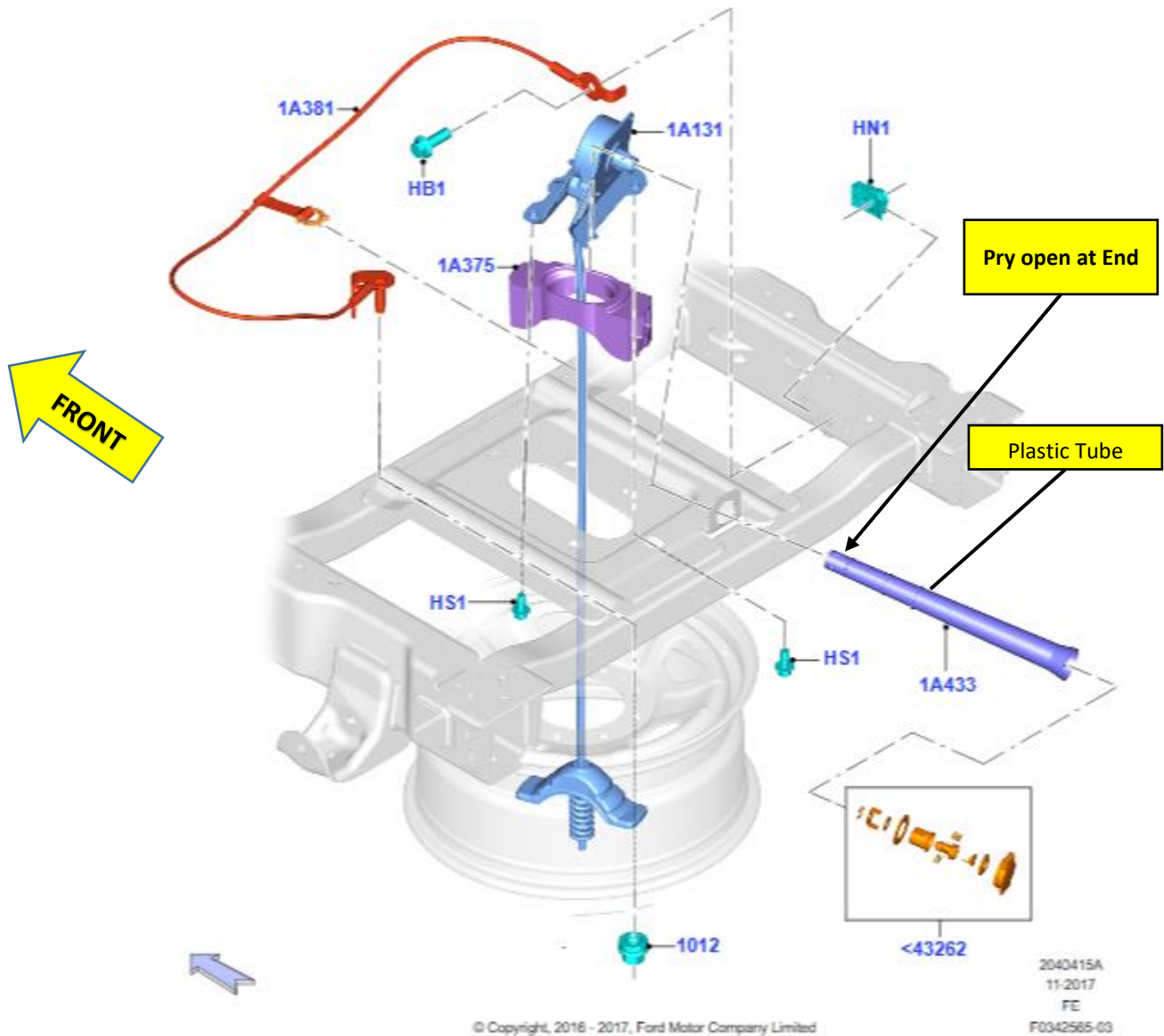

Figure 4 – Exploded view of Spare Tire Mechanism from Ford Parts (2017 F-250/F-350 shown)

- 9.1.4. Remove two (2) OE Bolts holding Lift Mechanism to Crossmember (see “HS1” in above image), then twist Mechanism counterclockwise to remove from Crossmember and lift out of Vehicle. Retain all parts for future use, if desired.

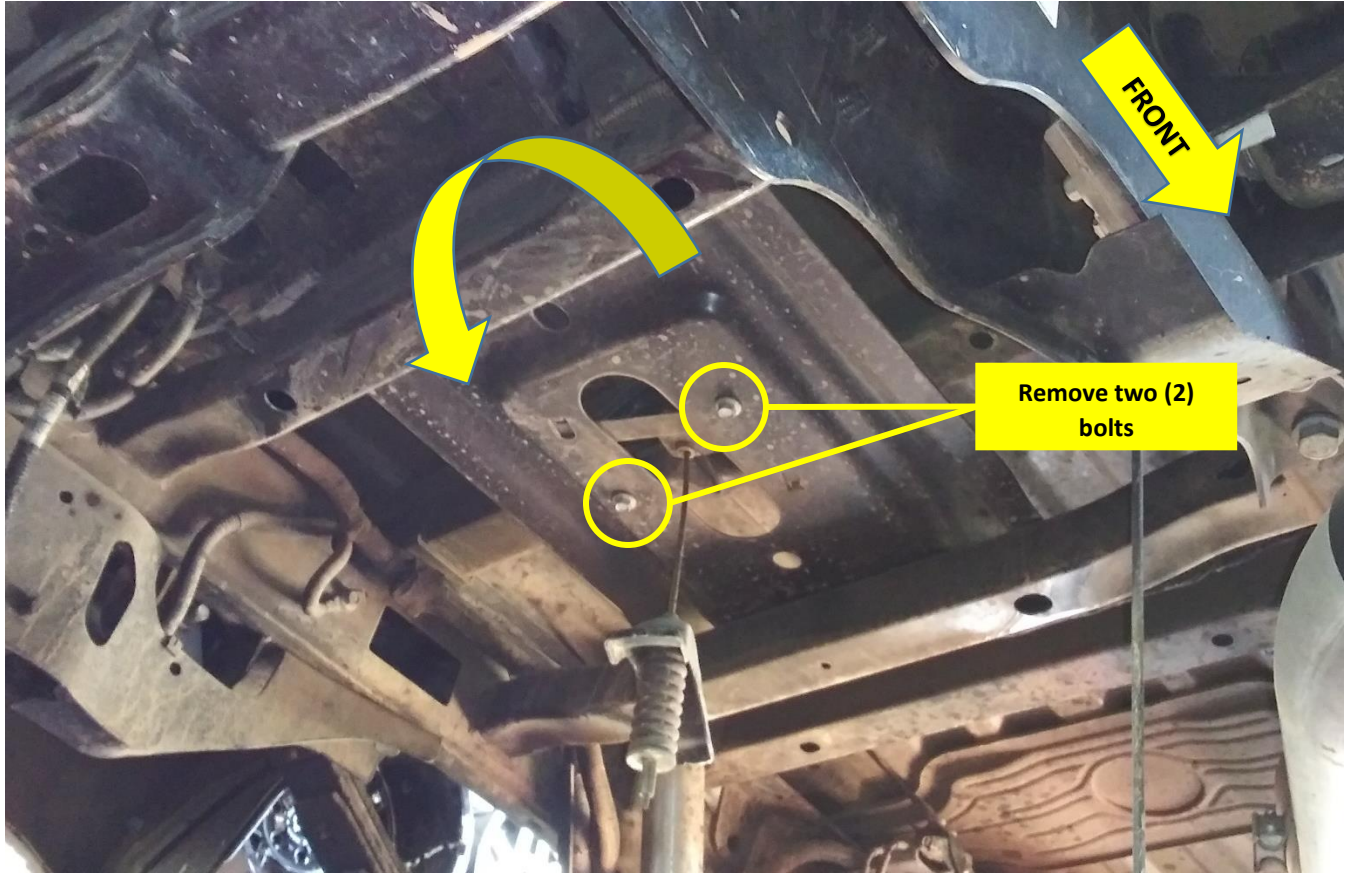

Figure 5 – Underbody view of Spare Tire Mechanism and Crossmember (2017 F-250 shown)

### 9.2. Install Air Horn Bracket (SD17-304)

9.2.1. Using [Hardware #H1, H2, H3, H4, & H5](#) install Brackets onto Spare Tire Crossmember, as shown below. It is recommended to apply medium-strength Loctite to Bolts and **final torque to 75 in-lbs.**

**NOTE:** Initially install Large Bracket -304 using only two (2) bolts, to facilitate alignment with other bolts. Then insert remaining hardware into front are rear slots, from top down into Bracket

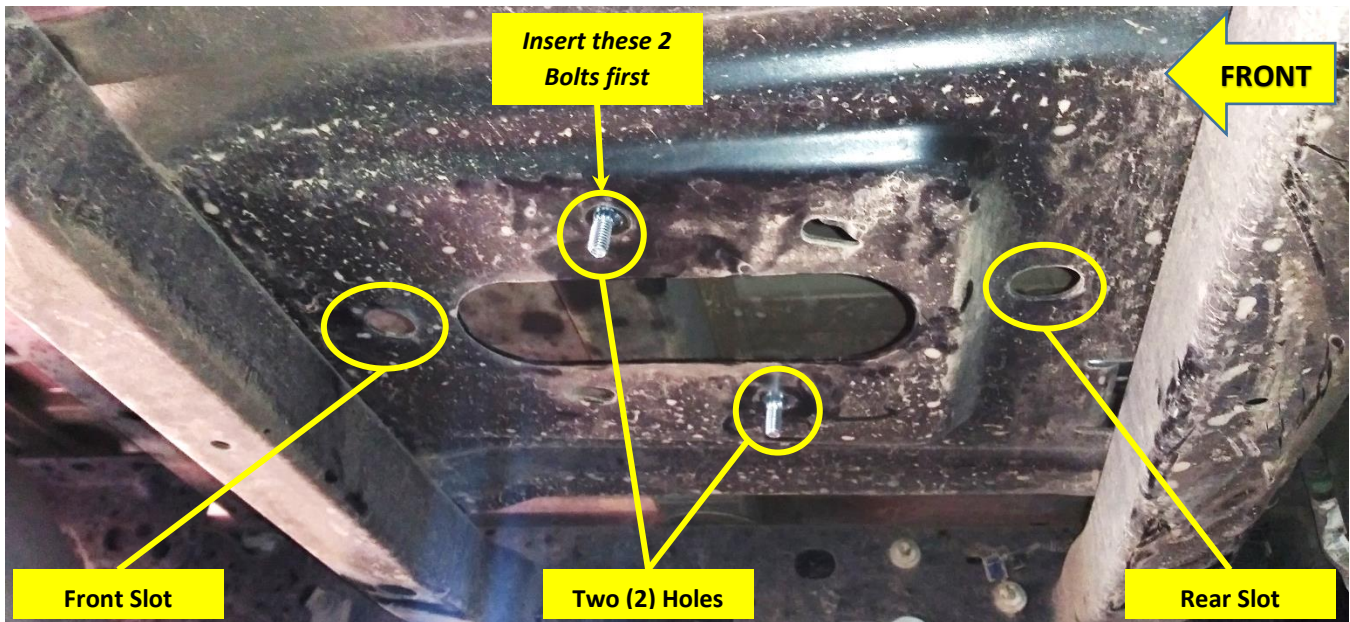

Figure 6 – Underbody view of Crossmember with Mounting Holes and Bolts installed (2017 F-250 shown)

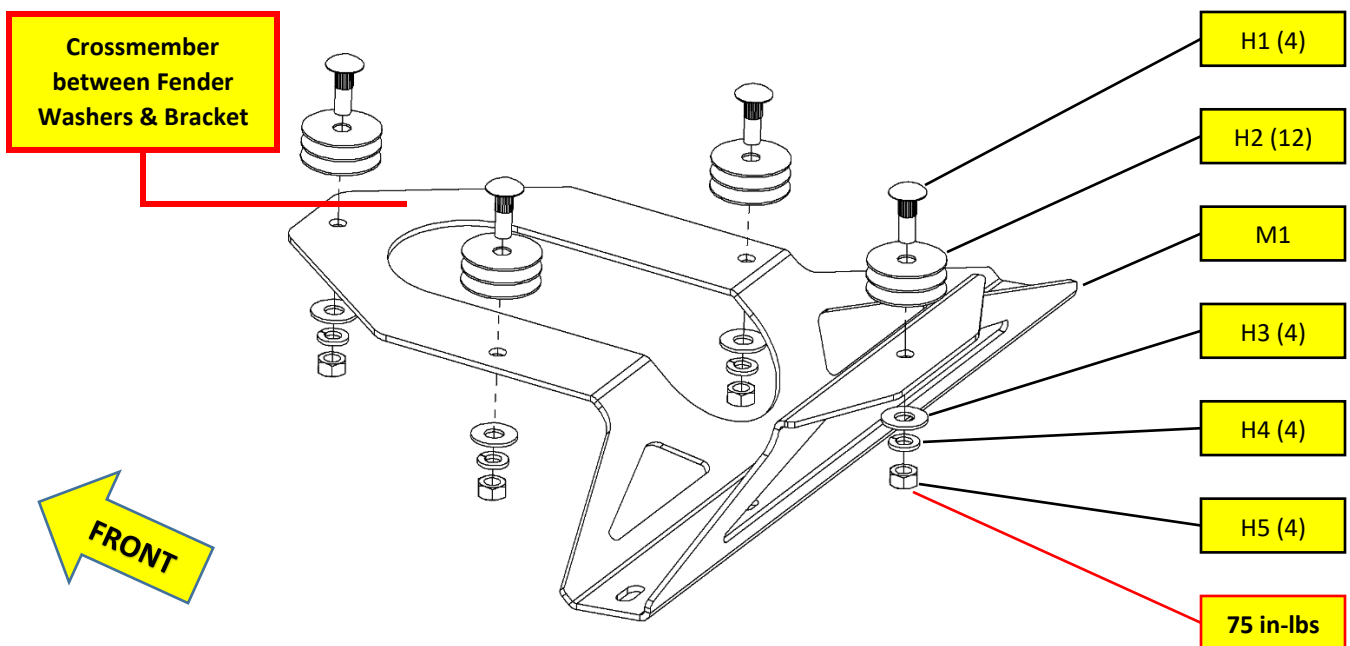

Figure 7 – Installing SD17-304 Bracket (Exploded view shown)



# SDKIT17-230/734STD

## Installation and Operation Manual

### 9.3. Install Air Horn Ore Support Bracket (SD17-306) – 734STD ONLY

9.3.1. Remove front most nut, lock washer, and flat washer, then install Support Bracket, as shown below; ensure it is correctly oriented. Re-install hardware and **final torque to 75 in-lbs.**

**NOTE:** This step is excluded from 230STD Plastic Horns, as they do not include Horn Supports.

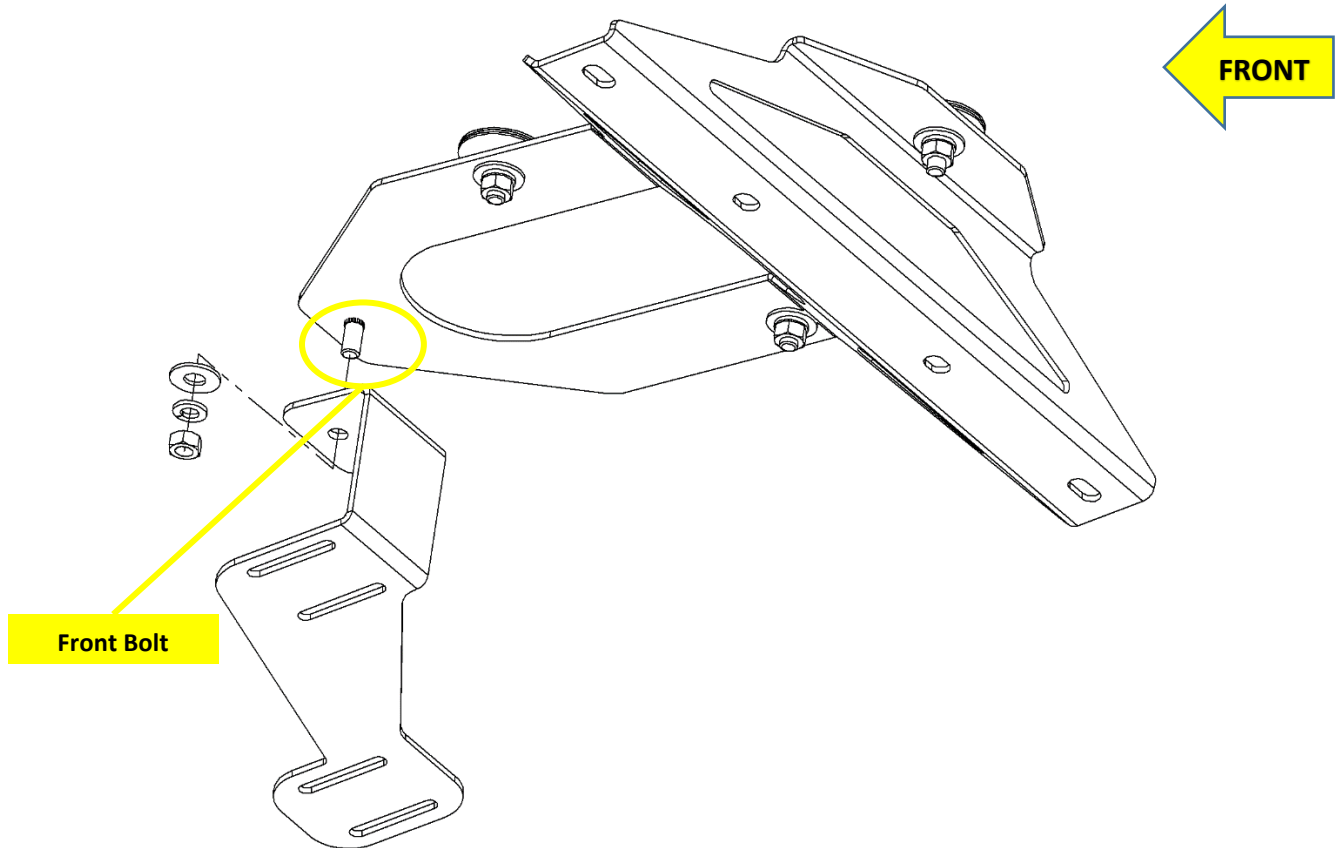

Figure 8 – Installing Horn Ore Support Bracket SD17-306 (Exploded view shown) – 734STD ONLY



# SDKIT17-230/734STD

## Installation and Operation Manual

### 9.4. Install Air Horn Sub-Assembly

- 9.4.1. Using Hardware included (\*) inside of Horn Packaging, install Air Horn sub-assembly onto Bracket, as shown below then **final torque to 75 in-lbs.**
- 9.4.2. Using Hardware included (\*) inside of Horn Packaging, install Horn Support Ore Locks, as shown below. Finger tighten hardware on Ore Locks at this time.

**\*\*NOTE:** 230STD does NOT include Horn Ore Supports.

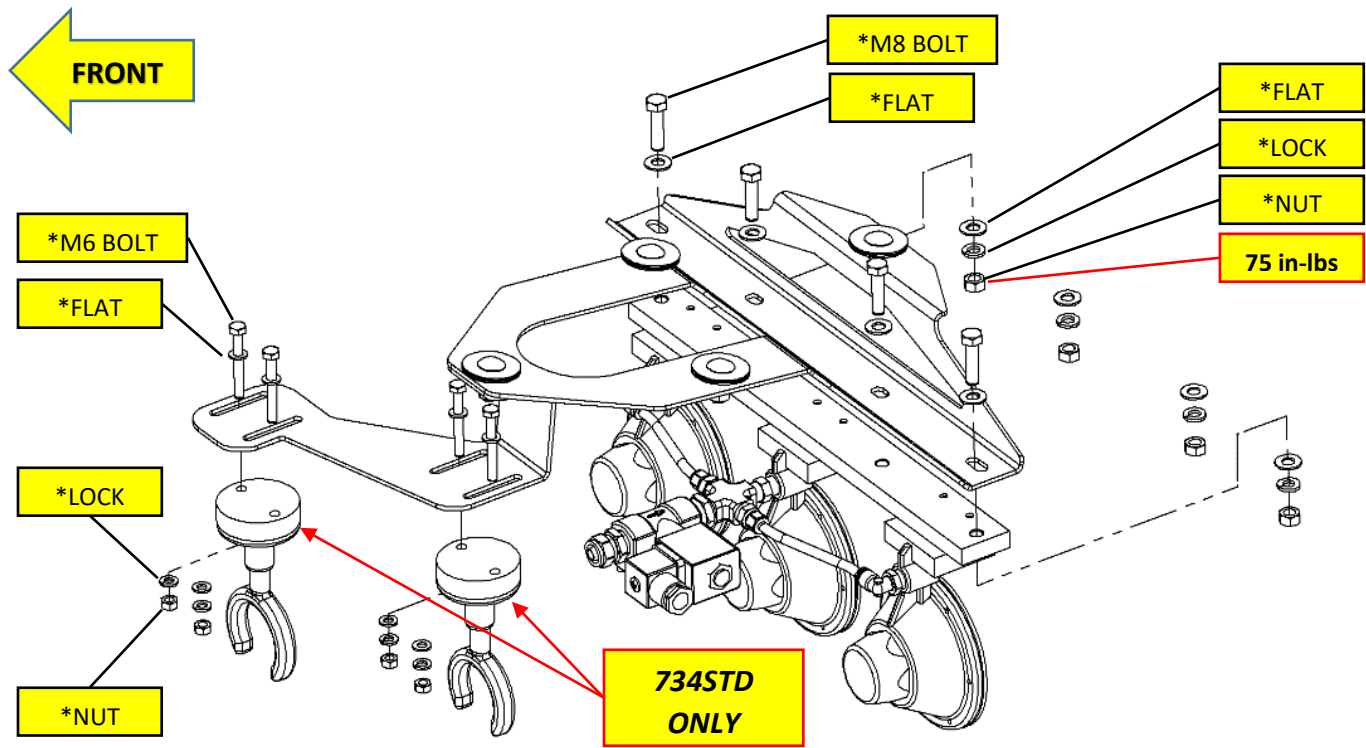

Figure 9 – Air Horn Sub-Assembly installation (Exploded View of 730 Horn with Ore Supports shown)

### 9.5. Install Air Tank Fittings on Air Tank & Connect Air Tubing

- 9.5.1. If Air Tank is already installed in vehicle, it may be required to remove Air Tank to gain enough space.
- 9.5.2. If Air Tank has not been installed yet, assemble Fittings during bench assembly.
- 9.5.3. Install Air Fitting #F1 (or #F2/F3) into port shown in below illustration.
- 9.5.4. Apply 1-2 drop of Kleinn Air Horn juice on end of each male thread before installing Fittings, hand tighten, then further tighten 1/4-1/2 Turn with wrench. *Adjust angle of Fitting towards rear as shown below, by tightening further or allowing Air Horn Juice to cure in position.*

**NOTE:** Follow directions in SDKIT17-230/734 Technical Manual for removal/install of Air Tank

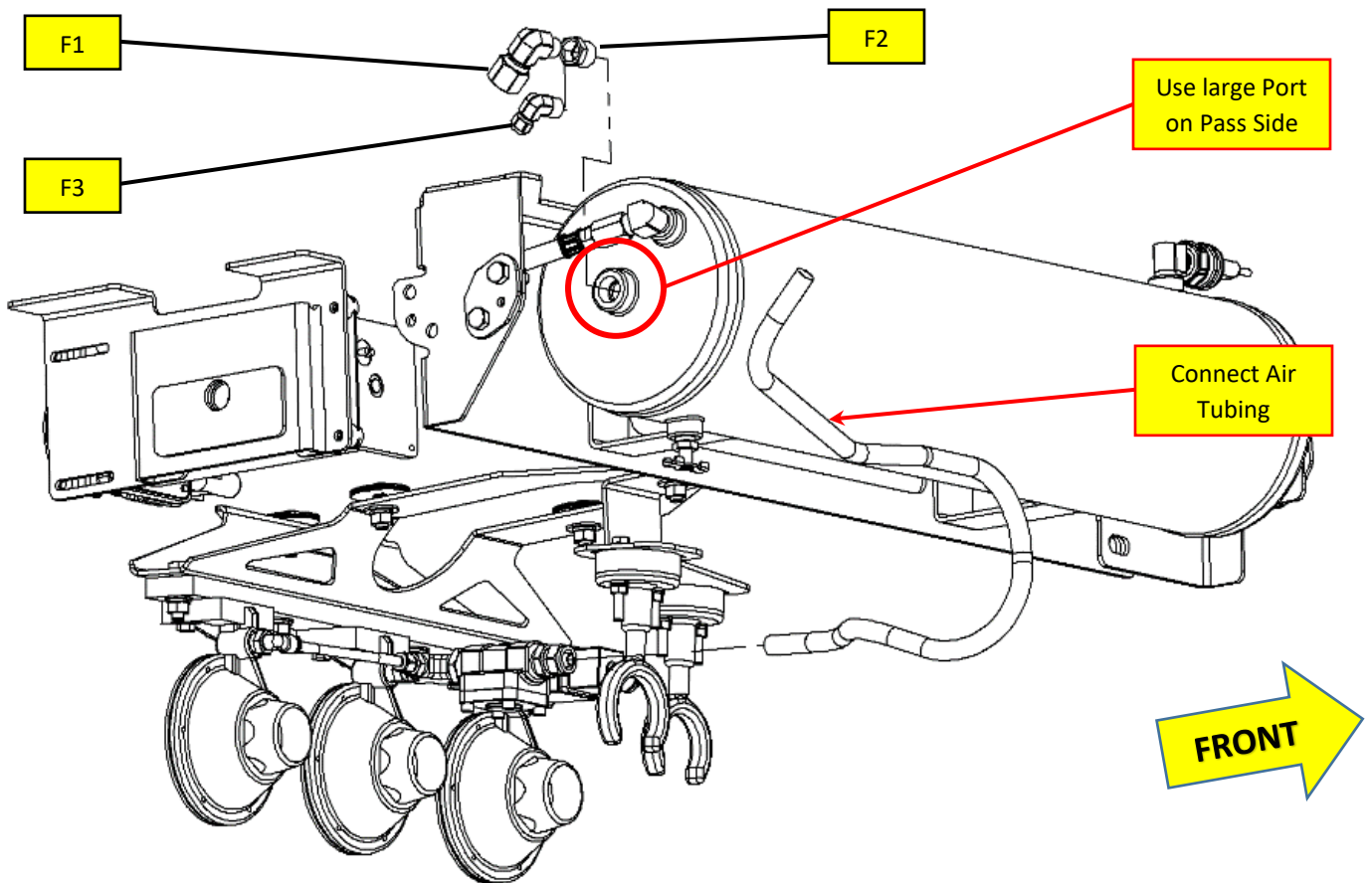

Figure 10 – Installing Air Fittings onto Air Tank (Exploded view shown as if installed in Vehicle)

### 9.6. Final Trumpet Installation

- 9.6.1. Re-attach Trumpets to Air Horn Drivers, as shown below. Ensure Trumpets are firmly tightened by grasping Metal/Chrome Collar, as performed earlier.
- 9.6.2. On 734STD, apply light grease or Vaseline to inside rubber face on Ore Locks, then insert Trumpets through Ores and tighten firmly.

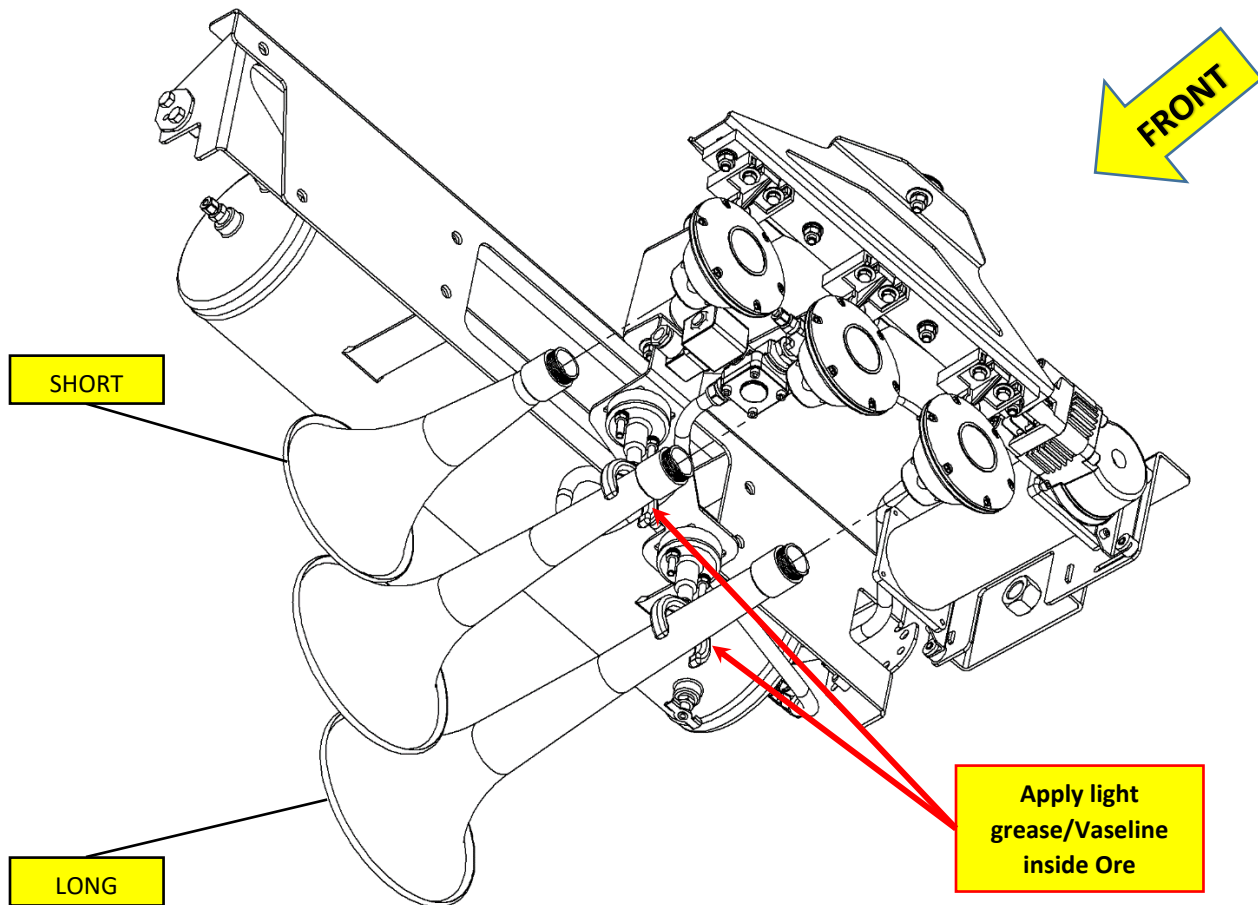

Figure 11 – Re-attaching Trumpets (Exploded View shown as if installed in vehicle)

End of Section



### 10. On-Vehicle Electrical Installation

**CAUTION:** Follow all recommended safety precautions for working on vehicle's electrical system; consult vehicle owner's manual for further instruction.

#### 10.1. Relay and Fuse Diagram for Air Horn System

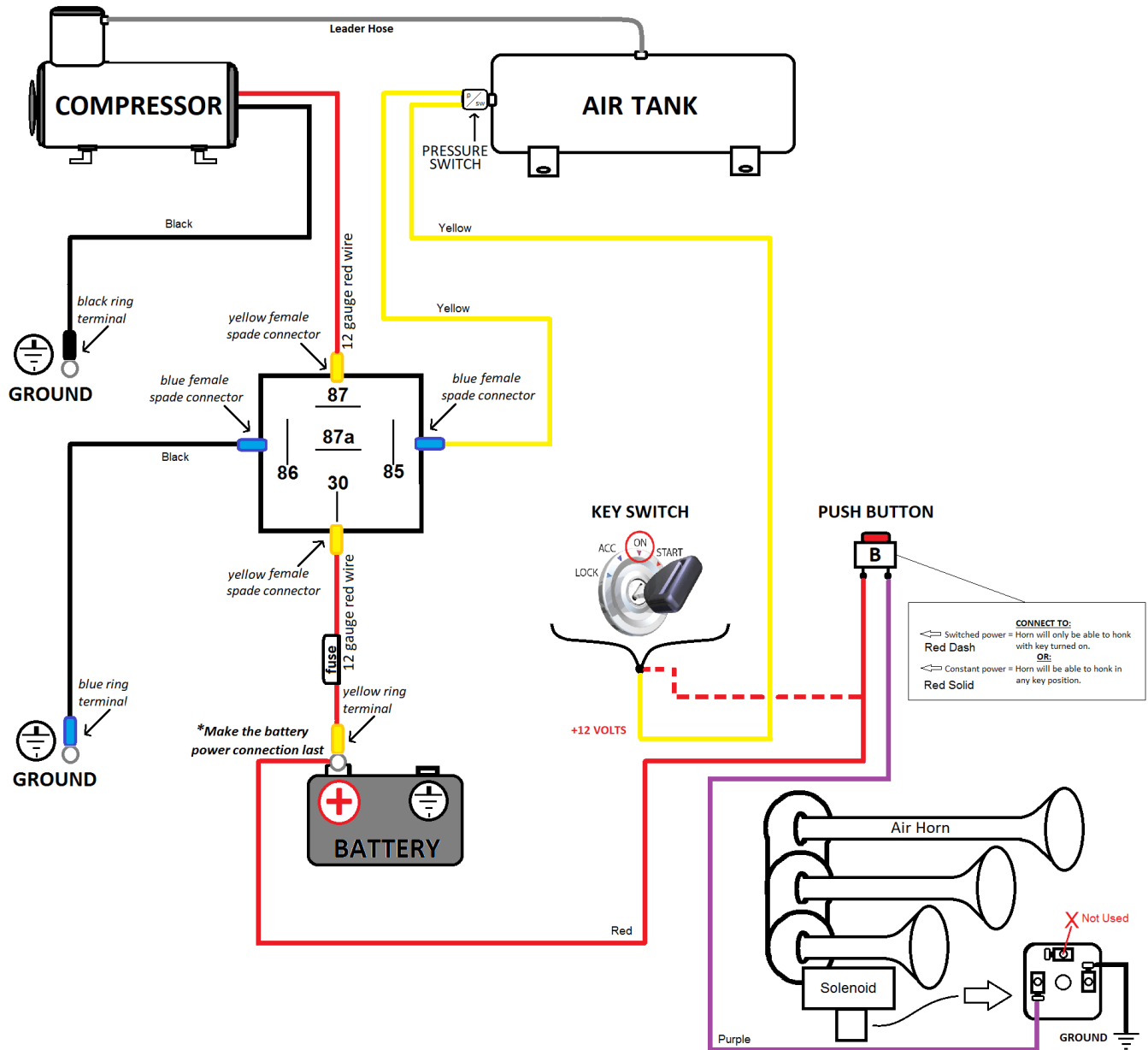

Figure 12 – Suggested Ignition Relay Diagram for Air Horn System (230/730 Horn Shown)

### 10.2. Suggested Wire Routing for Air Horn System

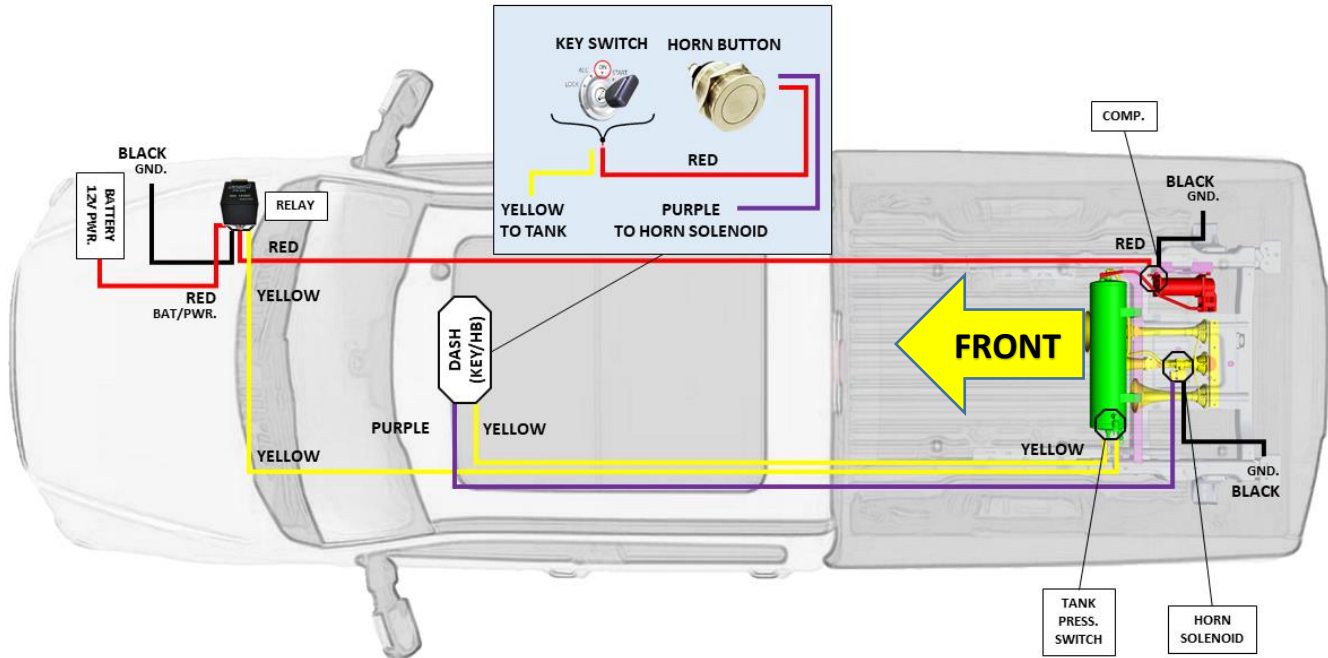

Figure 13 – Suggested Wire Routing for Horn, Air Compressor, and Pressure Switch (SDKIT17-734STD Shown)

### 10.3. Disconnect Vehicle Battery(s)

#### 10.3.1. Consult Owner’s Manual.

### 10.4. Connect Wiring to Fuse and Relay

10.4.1. Find a suitable location for supplied Fuse and Relay. Shown below is an example location under hood next to Battery mounted on firewall. Use supplied self-tapping screws, as necessary.

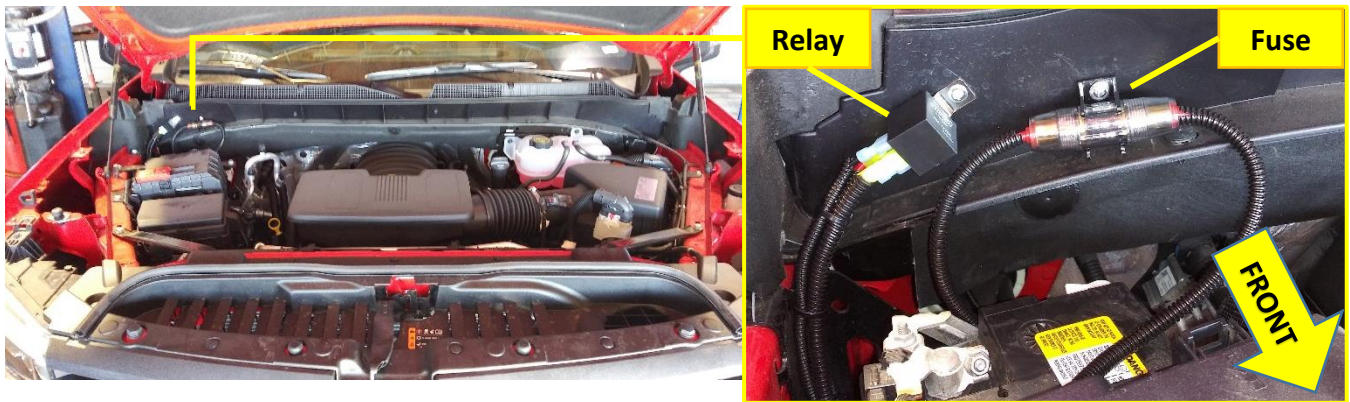

Figure 14 – Relay and Fuse location example under hood (Shown in example vehicles)

10.4.2. Install supplied fuse holder on end of power wire by cutting the loop in fuse holder and connecting supplied Ring terminal to one end and Butt connector on other end.

**CAUTION:** Do not install 30-amp fuse until all electrical connections are final.

### 10.5. Install Horn Button

- 10.5.1. Find a suitable location for Horn Button (i.e., in dash, center console, etc.); verify location has 1"+ of clearance behind for terminal connectors. Mark location for drilling.
- 10.5.2. Drill a 3/4" hole at location. Route Horn Button wires to hole then slide push-button retaining nut over wires and connect wiring. Install Button into hole and tighten retaining nut from backside.



Figure 15 – Horn Button Installed in Dash and OE Upfitter Switches (Shown in example vehicles)

**NOTE:** FOR VEHICLES WITH OE/FACTORY UPFITTER SWITCHES:

If your vehicle is equipped with factory upfitter (i.e., auxiliary) switches, you may elect to use them for your Kleinn Air Horn kit; consult Owner's Manual, or dealership for further instructions on what wire terminals/fuse block location to use and programming required.

### 10.6. Connect Pressure Switch

- 10.6.1. Route wiring, as desired to Air Tank and connect to Pressure Switch, per wiring diagram.  
**NOTE:** Either pressure switch wire can be connected to Relay or Ignition; they are identical.

### 10.7. Connect Air Compressor

- 10.7.1. Route wiring, as desired to Air Compressor and connect, per wiring diagram.

### 10.8. Connect Air Horn Solenoid(s)

- 10.8.1. Route wiring, as desired to Air Horn and connect to Solenoid(s), per wiring diagram.  
**NOTE:** Either Air Solenoid wire can be connected to Power (PWR) or Ground (GND); they are identical.

### 10.9. Secure Wiring to Vehicle

- 10.9.1. Insert all wiring into included wire loom and ensure loom is away from all sharp edges, hot/moving vehicle parts (i.e., exhaust, engine, radiator) and fasten securely to vehicle using supplied zip ties, or equivalent.



# SDKIT17-230/734STD

## Installation and Operation Manual

### 11. Final Steps & Testing

#### 11.1. Reconnect Vehicle Battery(s)

**CAUTION:** Before connecting vehicle battery(s), verify all wiring is properly connected and no shorts exists. Use of Multi-Meter, or Test Light is recommended to check continuity of all connections.

#### 11.2. Test Air Compressor

- 11.2.1. Turn vehicle ignition to on position and allow compressor to fill Air Tank. Initial fill may take approximately 1.5-3 minutes; Air Compressor should shut off automatically once full pressure is achieved.
- 11.2.2. If compressor runs excessively (i.e., 5 minutes or more), disconnect electrical power to Air Compressor and listen for air leaks in system. Repair any problems and retest; contact Kleinn technical support if problem persists.
- 11.2.3. Inspect all air line connections (i.e., Air Tank fittings, Quick Connect fittings, Air Horn fittings, etc.) for leaks by using a soap and water solution sprayed directly onto fittings
- 11.2.4. System must be pressurized or at least Air Compressor running
- 11.2.5. If an air leak is found:
- 11.2.6. Safely release air pressure from system (i.e., slowly open drain valve)
- 11.2.7. Disassemble leaky connection, re-seal and reinstall fittings as needed

#### 11.3. Test Train Horns

- 11.3.1. Allow Air Compressor to run and shut-off automatically (i.e., Air Tank is full)
- 11.3.2. Verify all tubing and electrical wire is securely fastened to vehicle, brackets, or kit parts; if necessary, use extra zip ties to hold tubing and wire in place
- 11.3.3. Ensure all nearby persons have adequate hearing protection and provide courtesy warning to neighbors or others in vicinity

**WARNING:** NEVER operate train horns with ears close to trumpets or in an enclosed space without substantial hearing protection (i.e., > Ear Plugs and Ear Muffs) for all persons closer than 100 feet from vehicle. Never operate train horns outdoors when persons are near vehicle without adequate hearing protection.

- 11.3.4. Briefly activate Horns by pressing Horn Button for one (1) second; repeat three (3) times with a short rest period between (i.e., 1-3 seconds)
- 11.3.5. Horns should sound as expected and be loud; [click to listen to example 230 Kit](#)
- 11.3.6. Horn sound/loudness will taper quickly as Air Tank loses pressure
- 11.3.7. Allow Air Compressor to refill tank, if needed and activate Horns for longer three (3) second period to ensure Horns are functioning properly.

#### 11.4. Test Quick Connect Coupler

- 11.4.1. Allow Air Compressor to refill tank, if needed
- 11.4.2. Attach supplied INF-1 inflator kit to Quick Connect Coupler and verify adequate air pressure is available
- 11.4.3. Test fill tires on vehicle, bicycle, etc.
- 11.4.4. Use Air Blow Gun
- 11.4.5. Use Air Impact Gun

End of Section



# SDKIT17-230/734STD

## Installation and Operation Manual

### 12. General Operation

#### 12.1. Compressor Operation

**WARNING:** NEVER operate Air Compressor above its MAXIMUM PRESSURE RATING (see label on body). Operation exceeding maximum pressure will damage Compressor and potential Air System failure.

- 12.1.1. Kleinn's Oil-Less Compressor is equipped with an automatic thermal overload protection circuit, designed to protect air compressor from overheating and permanent damage.
- 12.1.2. Automatic thermal overload protector will automatically reset after 30 minutes.
- 12.1.3. To prevent discharge of vehicle's battery and for best performance, keep vehicle's engine running while using Air Compressor for any prolonged use (i.e., filling tires, using air tools, etc.).

#### 12.2. Horn Operation

- 12.2.1. Allow Air Compressor to run until it shuts off automatically (i.e., Air Tank is full), or for at least one minute in between horn activations.
- 12.2.2. Press Horn Button to activate Horns
- 12.2.3. Horn sound/loudness will taper quickly as Air Tank loses pressure.
- 12.2.4. Horns should sound for 3-7 seconds depending on kit and tank size

**WARNING:** NEVER operate train horns with ears near trumpets or in an enclosed space without [hearing protection](#) (i.e., > Ear Plugs/Muffs) for all persons closer than 100 feet from vehicle. Never operate train horns outdoors when persons are near vehicle without hearing protection.

End of Section

### 13. Routine Maintenance

Perform following steps at least once during recommended intervals.

- 13.1. Yearly, or every 12000 miles verify all mounting fasteners are properly torqued; applying witness marks across fasteners and mounting parts is good practice to quickly ensure fasteners have not moved.
- 13.2. Yearly, or every 12000 miles inspect OE wiring, tubing, cables, etc. where Kit parts may touch, to verify no abrasion or rubbing.
- 13.3. Yearly, or every 12000 miles remove all road grime and mud from mounting brackets and kit parts using clean water from a garden hose; pay special attention to corners where dirt may collect. Touch up all paint chips using automotive grade enamel in either spray, or brush form.

**NOTE:** High-pressure washers may damage part finishes and *must* be used with care. Do this more frequently if traveling regularly off-road, or in winter climates with road salts.

- 13.4. Yearly, or every 12000 miles check electrical and air fitting connections and wires for abrasion, corrosion, or other damage. Replace damaged components.

**NOTE:** if system runs continuously or turns on unexpectedly, leaks or intermittent electrical connection may be present.

- 13.5. Monthly, or every 10 hours of compressor run time, drain moisture from Air Tank using Drain Valve installed at bottom of Tank.

**WARNING:** Failure to regularly drain Air Tank may result in corrosion inside Tank and possible failure in Tank or Air Tubing, causing injury.

- 13.6. Yearly, or every 12000 miles clean, or replace Air Compressor Air Filter element. Replacement frequency depends on operating frequency and conditions of environment (i.e., daily use requires more frequent changes).

**NOTE:** NEVER lubricate or add liquids to Compressor

End of Section