

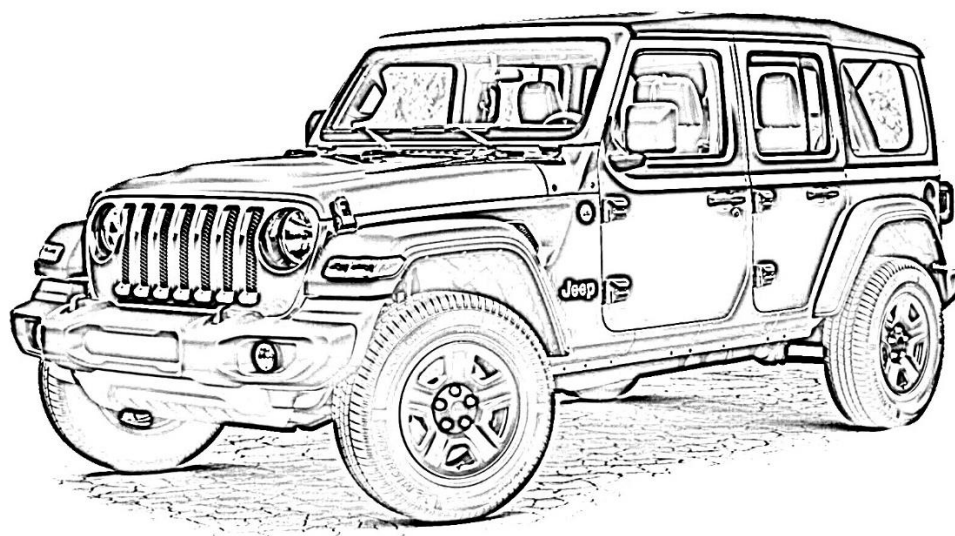

JL-JK-OBA INSTALLATION MANUAL





JL-JK-OBA

Installation and Operation Manual

Table of Contents

1. LIST OF FIGURES
2. How to Use this Manual
 - 2.1. Interactive Manual using Adobe Reader
 - 2.2. Your Kit SKU Number and this Manual
 - 2.3. Illustration/Photo Details and Orientation
3. Safety First
4. Application Chart
 - 4.1. 100% Direct Bolt-On Vehicle List
 - 4.2. **Excluded Vehicles
 - 4.3. Aftermarket Product Compatibility
5. Installation Overview
 - 5.1. Kit Layout and System Location(s)
 - 5.2. Approximate Installation Time
 - 5.3. ***Quick Install Outline
6. List of Tools and Supplies
 - 6.1. Standard Tool List (Required)
 - 6.2. Special Tool List (Recommended)
 - 6.3. Shop Consumables List (Recommended)
7. Parts List
 - 7.1. Parts List covers following SKU Numbers
 - 7.2. Pre-Packaged Electro-Mechanical Items
 - 7.3. Air Fittings and Related Items
 - 7.4. Electrical Small Components and Related Items
 - 7.5. Bolt-On Mounting Brackets & Special Hardware
 - 7.6. Hardware/Fasteners
8. On-Vehicle Electrical Installation
 - 8.1. Relay and Fuse Diagram for Air Compressor and Air Tank Pressure Switch
 - 8.2. Suggested Wire Routing for Air Compressor and Air Tank Pressure Switch
 - 8.3. Disconnect Vehicle Battery(s)
 - 8.4. Connect Wiring to Relay(s) and Fuse(s), then Attach to Vehicle
 - 8.5. Route Wiring
9. Bench Assembly Steps



JL-JK-OBA

Installation and Operation Manual

- 9.1. Air Tank Fittings
- 9.2. Attach Compressor(s) onto Skid Plate Bracket (JK-101)
- 9.3. Attach Air Tank Straps (JK-202) to Air Tank Bracket (JK-201) and Form Straps
10. On-Vehicle Mechanical Assembly Steps
 - 10.1. **JK ONLY** - Air Tank Bracket (JK-201) to Frame Installation
 - 10.2. **JL ONLY** - Adapter Bracket (JL-204) to Frame Installation
 - 10.3. **JL ONLY** - Air Tank Bracket (JK-201) to Frame Installation
 - 10.4. Air Tank to Tank Bracket Installation
 - 10.5. Skid Plate and Compressor Installation (JK-101)
 - 10.6. Connect Air Compressor Leader Hose to Air Tank
 - 10.7. Connect Remote Quick Connect Kit to Vehicle
11. Initial Testing of Kit
 - 11.1. Reconnect Vehicle Battery(s)
 - 11.2. Test Air Compressor
 - 11.3. Test Quick Connect Coupler
12. General Operation of Kit
 - 12.1. Compressor Operation
13. Routine Maintenance



JL-JK-OBA

Installation and Operation Manual

2. How to Use this Manual

2.1. Interactive Manual using Adobe Reader

It is recommended to open this digital PDF using Adobe Reader[®] to take advantage of following key features:

- **Hyperlinks** ([blue underlined text](#)) allow access to additional content via internet; click/tap to activate
 - Includes [Installation Figures](#) and "[Figure xx](#)"
 - **Table of Contents** page allows easily navigating this manual; click/tap any section line to go to it
 - **Bookmarks** allow quickly navigating to any section; click/tap
 - **Zoom IN** on pictures by pressing "CTRL and +" at same time on PC, or pinch in on smart devices
 - **Zoom OUT** on pictures by pressing "CTRL and -" at same time on PC, or pinch out on smart devices
-

2.2. Your Kit SKU Number and this Manual

This manual covers installation, testing, and operation of following SKU part numbers

2.2.1. **JL-JK-OBA** (i.e., On-Board Air System)

2.2.2. **JK6450** (i.e., Dual Compressor Upgrade)

NOTE: Illustrations and pictures contained herein may represent only one kit part number. Where critical differences exist between kits (i.e., different parts, orientation, mounting points, etc.), additional text, or necessary graphics are provided to minimize confusion.

Parts list explicitly state kit differences with **(BOLD TEXT)** inside parenthesis, shown below part number.

2.3. Illustration/Photo Details and Orientation

This manual may use digitally created illustrations, and/or actual photos of example vehicle. These graphics may not include exact items found on your vehicle (i.e., electrical wiring, fuel lines, body panels, etc.). Illustrations typically will be missing details and are for clarity to show critical mounting locations and orientation on vehicle.

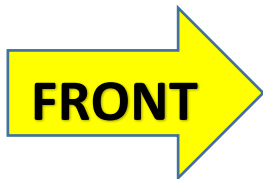

Throughout this manual yellow arrows with text reading "FRONT", may be present over illustrations and pictures. These arrows specify direction toward front of vehicle and provide clarity to how illustration is viewed.



JL-JK-OBA

Installation and Operation Manual

3. Safety First

Read manual thoroughly before starting installation of this kit. Verify you have all parts listed and that you clearly understand this installation procedure. Contact Kleinn technical support for any questions.

Installation of this kit requires **moderate mechanical aptitude**; seek professional help if you're not competent using hand tools in tight uncomfortable spaces, and around possibly rusted and sharp vehicle parts.

Before starting, obtain proper tools required to perform installation correctly, adequate lighting, eye protection, hearing protection for operating train horns, and hand protection to guard against sharp edges and metal burrs, which may be present on kit parts and vehicle parts.

Throughout this manual the following words may be used; be aware of their meaning and application.

CAUTION: means damage could occur to vehicle, or kit parts during, or after installation

WARNING: means injury could occur to you or others, including damage to vehicle, or kit parts

DANGER: means serious injury or death could occur to you or others during installation



JL-JK-OBA

Installation and Operation Manual

4. Application Chart

4.1. 100% Direct Bolt-On Vehicle List

JL-JK-OBA is a 100% direct bolt-on aftermarket product for Jeep vehicles listed in below chart; every effort has been made to verify correct fitment on these vehicles in their factory, non-modified conditions.

MODEL YR	MODEL	DRIVE	ENGINE	BODY	TRIM
2018-2019	JLU	ALL	3.6L**	4 DOOR	ALL**
2007-2018	JKU	ALL	3.6L	4 DOOR	ALL**

NOTE: All vehicles listed may require drilling holes for ground wires and installing switches, based on preference of installed switch locations and wire grounding points.

4.2. **Excluded Vehicles

JL-JK-OBA is NOT compatible with following JEEP vehicles:

- 4.2.1. ALL 2-Door Jeep JL
- 4.2.2. ALL 2-Door Jeep JK
- 4.2.3. Jeep JLU with 3.0L Diesel
- 4.2.4. Jeep JLU with Hybrid

4.3. Aftermarket Product Compatibility

- 4.3.1. This kit has been designed and tested to be compatible with leading manufacturers of aftermarket truck steps, such as Amp Research Power Steps[®] and all OEM standard and optional steps.
- 4.3.2. This kit has NOT been designed or tested for use with leading manufacturers of aftermarket exhaust systems.
- 4.3.3. This kit has NOT been designed or tested for use with leading manufacturers of aftermarket drivetrains, or suspension systems.

5. Installation Overview

5.1. Kit Layout and System Location(s)

JL-JK-OBA consists of following sub-systems, located on vehicle, as follows:

ITEM	DESCRIPTION	MOUNTING LOCATION	APPROX. INSTALL TIME
1	3 Gal. Air Tank	Under vehicle, in between driveshaft & exhaust. <i>JKU in front of Evap. Canister.</i>	2+ Hours
2	6450RC Air Compressor **Dual Air Compressor with JK6450 Upgrade Kit shown in this manual	Under vehicle, in between driveshaft & exhaust. <i>JKU in front of Evap. Canister.</i>	1-2 Hours

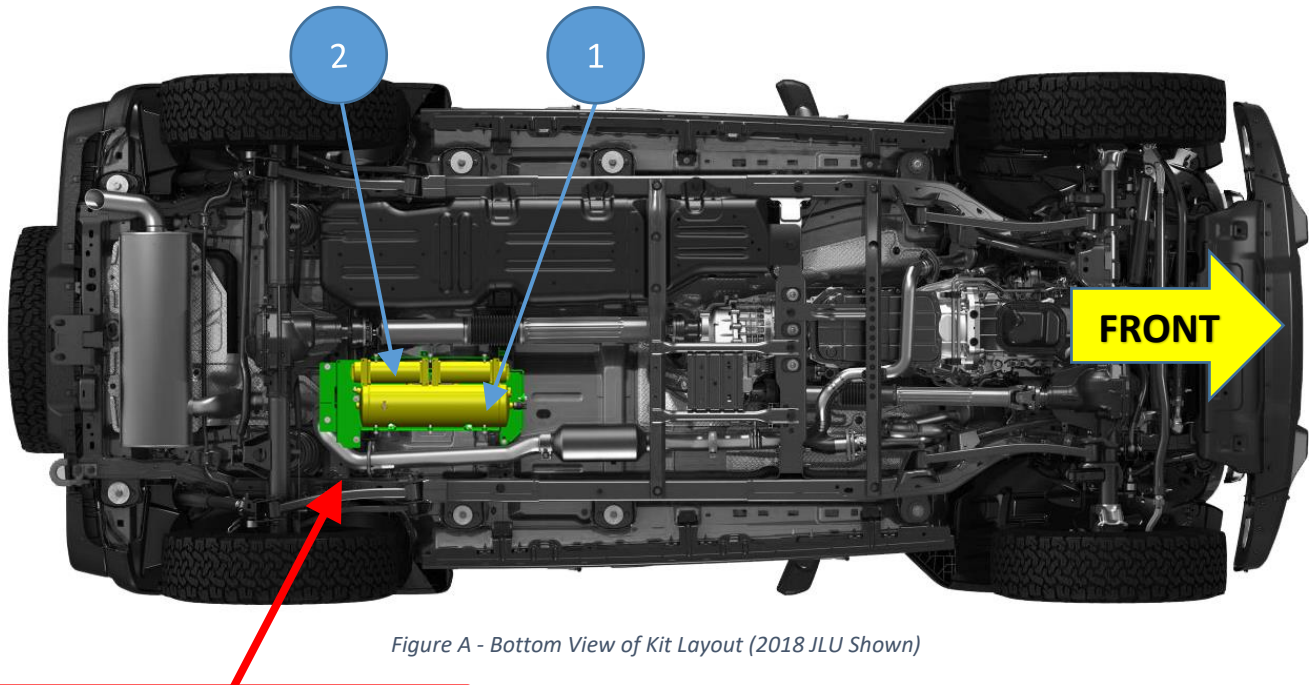

Figure A - Bottom View of Kit Layout (2018 JLU Shown)

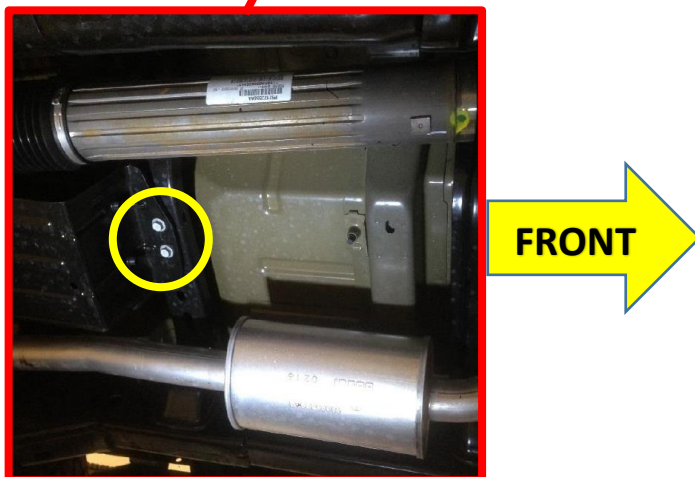

Figure B - Location Under JKU (Evaporative Canister attachment bolts shown circled)



JL-JK-OBA

Installation and Operation Manual

5.2. Approximate Installation Time

JL-JK-OBA is a multi-faceted product consisting of multiple mechanical, electrical, and pneumatic components.

For a typical home mechanic, auto enthusiast, or technician installing a Kleinn Bolt-On kit for first time, a professional installation job with setup and testing of final product, is estimated to take:

- **3-5 Hours**
-

5.3. ***Quick Install Outline

For person(s) with experience installing Kleinn bolt-on kits, JL-JK-OBA can be installed in an order similar to below:

1. Route Wiring, install Relay.
2. Bench Assemble Air Tank with Fittings.
3. Bench Assemble Air Compressor(s) to Skid Plate/Compressor Bracket (JK-101).
4. Install Air Tank Brackets (JK-201, JK-202, JK-203, JL-203, JL-204)
5. Install Air Tank to Air Tank Bracket.
6. Install Compressor Bracket (JK-101) to Air Tank Bracket (JK-201)
7. Connect Air Tank to Air Compressor(s).
8. Install Quick Connect Coupler and route Air Tubing
9. Test System and adjust, as needed



JL-JK-OBA

Installation and Operation Manual

6. List of Tools and Supplies

6.1. Standard Tool List (Required)

- 6.1.1. Basic mechanic's 3/8" drive socket sets with extensions
 - Inch Size Sockets (1/4" – 1" Hex)
 - Metric Size Sockets (6mm – 20mm Hex)
- 6.1.2. Basic mechanic's combination wrenches (box/open-end)
 - Inch Size Wrenches (1/4" – 1" Hex)
 - Metric Size Wrenches (6mm – 20mm Hex)
- 6.1.3. Basic mechanic's screwdriver set (Philips, Flat Head)
- 6.1.4. Diagonal Cutter/Wire Cutter Pliers
- 6.1.5. Wire Strippers
- 6.1.6. Wire Terminal Crimpers
- 6.1.7. Slip-Joint Pliers
- 6.1.8. Utility Knife, or Utility Razor blade
- 6.1.9. Magnetic retrieval tool

6.2. Special Tool List (Recommended)

- 6.2.1. 10-100 ft.-lb. torque wrench
- 6.2.2. 20-150 in.-lb. torque wrench
- 6.2.3. Multi-Meter for 12V DC electrical systems, or equivalent
- 6.2.4. 12V DC Test Light, or equivalent
- 6.2.5. Trim Panel Tool, for removing wiring push pins

6.3. Shop Consumables List (Recommended)

- 6.3.1. Quality Electrical tape
- 6.3.2. Di-electric grease for electrical connections
- 6.3.3. Heat Shrink tubing for electrical connections
- 6.3.4. Blue Loctite (i.e., Loctite PN 242), or equivalent
- 6.3.5. Sand Paper, or Wire Brushes for installing ground wires
- 6.3.6. Extra plastic zip ties > 6" long
- 6.3.7. Extra NPT sealant (i.e., Kleinn Air Horn Juice, Teflon tape, etc.)
- 6.3.8. Touch-up paint for frame/chassis
- 6.3.9. Typical cleanup supplies



JL-JK-OBA

Installation and Operation Manual

7. Parts List

7.1. Parts List covers following SKU Numbers

7.1.1. **JL-JK-OBA** (i.e., On Board Air System Only)

7.1.2. **JK6450** (i.e., dual compressor upgrade kit)

Unpackage and organize Kit across a large work area and verify all parts are included, as listed below. Contact Kleinn support if any questions arise.

7.1.3. Review pre-packaged items (i.e., train horn box, air compressor, air tank, etc.)

7.1.4. Review Air Fittings and Tubing

7.1.5. Review Wiring and Accessories

7.1.6. Review Bolt-On Mounting Brackets

7.1.7. Review Hardware/Fasteners

7.2. Pre-Packaged Electro-Mechanical Items

NOTE: Items in this section come in their own packages and may include additional items inside package

ITEM	QTY	PART NUMBER	DESCRIPTION	PICTURE
1	1 (2)*	6450RC *(2) with JK6450 add-on	6450RC Compressor Kit, with included hardware, and remote air supply line	



JL-JK-OBA

Installation and Operation Manual



7.3. Air Fittings and Related Items

ITEM	QTY	PART NUMBER	DESCRIPTION	PICTURE
2	1	6353RT	Air Tank, 9-Port	
3	1	52835	1/4" NPT, Drain Valve	
4	1	52175	1/4" NPT, 175 PSI Safety Valve	
5	4 (3)*	50040 *(3) included in JK6450	1/4" NPT Hex Plug	
6	1	51414L	1/4" NPT X 1/4" Compression Fitting, 90 Deg Elbow	
7	1 (2)*	59014 *(2) included in JK6450	1/4" NPT X 1/4" NPT, 90 Deg Elbow. Male to Female.	
8	1	2151	1/4" NPT Pressure Switch	





JL-JK-OBA

Installation and Operation Manual

9	1	1302	Quick Connect Air Coupler Kit, with relocation bracket	
10	1	INF-1	Inflator Kit, with Air Hose and Bag	
11	1	KLEINN AIR HORN JUICE	Thread Sealant for NPT Fittings	

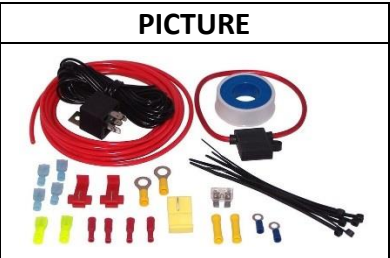
7.4. Electrical Small Components and Related Items

ITEM	QTY	PART NUMBER	DESCRIPTION	PICTURE
12	1	WIRE KIT	Full Wire Kit, with electrical connectors and zip ties	
13	1	1/4" WIRE LOOM, 20 ft. Long	1/4" Wire loom for electrical routing	
14	1	1/8" WIRE LOOM, 10 ft. Long	1/8" wire loom for electrical routing	



JL-JK-OBA

Installation and Operation Manual

7.5. Bolt-On Mounting Brackets & Special Hardware

ITEM	QTY	PART NUMBER	DESCRIPTION	PICTURE
15	1	JK-101	COMPRESSOR MOUNTING BRACKET, SKID PLATE	
16	1	JK-201	AIR TANK MOUNTING BRACKET	
17	2	JK-202	AIR TANK STRAP	
18	1	JK-203	JK FRAME STRAP FOR JKU ONLY (SHORTER STRAP)	
19	1	JL-203	JL FRAME STRAP FOR JLU ONLY	
20	1	JL-204	JK-JL ADAPTER, FRAME FOR JLU ONLY	



JL-JK-OBA

Installation and Operation Manual

7.6. Hardware/Fasteners

ITEM NO.	PART TYPE	PART SIZE	QTY.	WHERE USED
1	HEX BOLT, GRADE 2, ZINC-PLATED	1/4"-20 X 1" LONG	4	TANK STRAPS (4)
2	HEX BOLT, GRADE 2, ZINC-PLATED	3/8"-16 X 1" LONG	7	SKID PLATE (6) MOUNTING STRAP (1)
3	HEX BOLT, GRADE 2, ZINC-PLATED	7/16"-14 X 1"	1	MOUNTING STRAP (1) FOR JKU ONLY
4	HEX BOLT, GRADE 2, ZINC-PLATED	7/16"-14 X 2"	1	TANK BRACKET TO FRAME – FRONT (1) FOR JKU ONLY
5	HEX BOLT, GRADE 2, ZINC-PLATED	7/16"-14 X 2.5"	1	TANK BRACKET TO FRAME - REAR (1) FOR JKU ONLY
6	SQUARE NECK BOLT, GRADE 2, ZINC-PLATED	7/16"-14 X 1"	4	ADAPTER BRACKET (3) MOUNTING STRAP (1) FOR JLU ONLY
7	HEX BOLT, GRADE 8.8, ZINC-PLATED	M6 X 1 X 30 LONG	1	TANK BRACKET TO FRAME (1) FOR JLU ONLY
8	HEX BOLT, GRADE 8.8, ZINC-PLATED	M12 X 1.5 X 25 LONG	2	ADAPTER BRACKET TO FRAME (2) FOR JLU ONLY
9	HEX NUT, GRADE 2, ZINC-PLATED	10-24	8	COMPRESSORS (8)
10	HEX NUT, GRADE 2, ZINC-PLATED	7/16"-14	4	ADAPTER BRACKET (3) FOR JLU ONLY TANK BRACKET TO FRAME - FRONT/REAR (2) FOR JKU ONLY MOUNTING STRAP (1)
11	FLAT WASHER, SAE, ZINC-PLATED	1/4" ID X 0.63" OD	4	TANK STRAPS (4)
12	FLAT WASHER, FENDER, ZINC-PLATED	5/16" ID X 1.25" OD	1	TANK BRACKET TO FRAME (1) FOR JLU ONLY
13	FLAT WASHER, SAE, ZINC-PLATED	3/8" ID X 0.82 OD	7	SKID PLATE (6) MOUNTING STRAP (1)



JL-JK-OBA

Installation and Operation Manual

14	FLAT WASHER, SAE, ZINC-PLATED	7/16" ID X 0.93" OD	6	ADAPTER BRACKET (3) FOR JLU ONLY MOUNTING STRAP (1) FOR JLU ONLY TANK BRACKET TO FRAME – TOP/BOTTOM (4) FOR JKU ONLY MOUNTING STRAP – TOP/BOTTOM (2) FOR JKU ONLY
15	FLAT WASHER, DIN, ZINC-PLATED	M5 ID X 10 OD	8	COMPRESSORS (8) INCLUDED IN COMPRESSOR BOXES
16	FLAT WASHER, DIN FENDER, ZINC-PLATED	M6 ID X 18 OD	1	TANK BRACKET TO FRAME (1) FOR JLU ONLY
17	FLAT WASHER, METRIC DIN 125, ZINC-PLATED	M12 X 24 OD	2	ADAPTER BRACKET TO FRAME (2) FOR JLU ONLY
18	LOCK WASHER, SPLIT LOCK, ZINC-PLATED	1/4"	4	TANK STRAPS (4)
19	LOCK WASHER, SPLIT LOCK, ZINC-PLATED	3/8"	7	SKID PLATE (6) MOUNTING STRAP (1)
20	LOCK WASHER, SPLIT LOCK ZINC-PLATED	7/16"	4	ADAPTER BRACKET (3) FOR JLU ONLY TANK BRACKET TO FRAME - FRONT/REAR (2) FOR JKU ONLY MOUNTING STRAP (1)
21	LOCK WASHER, STANDARD SPLIT, ZINC-PLATED	M5	8	COMPRESSORS (8) INCLUDED IN COMPRESSOR BOXES
22	LOCK WASHER, SPLIT LOCK, ZINC-PLATED	M6	1	TANK BRACKET TO FRAME (1) FOR JLU ONLY
23	LOCK WASHER, SPLIT LOCK, ZINC-PLATED	M12	2	ADAPTER BRACKET TO FRAME (2) FOR JLU ONLY
24	RUBBER EDGE TRIM (U)	7.5" LONG	2	AIR TANK (2)
25	RUBBER EDGE TRIM (C)	9" LONG	2	AIR TANK (2)

End of Section

8. On-Vehicle Electrical Installation

CAUTION: Follow all recommended safety precautions for working on vehicle's electrical system; consult vehicle owner's manual for further instruction.

8.1. Relay and Fuse Diagram for Air Compressor and Air Tank Pressure Switch

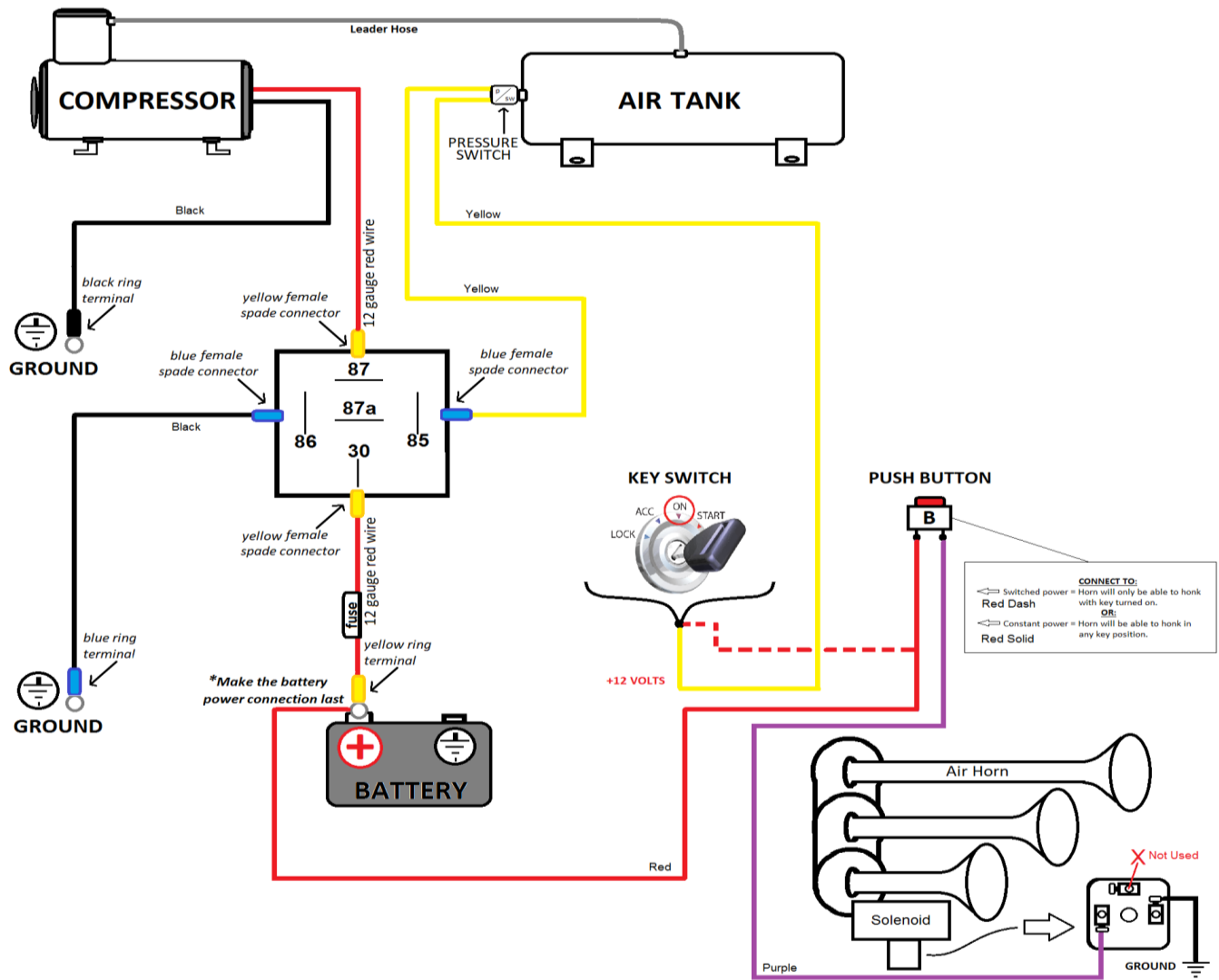

Figure 1 - Suggested Ignition Relay Diagram for JL-JK-OBA; Air Horn Also Shown

8.2. Suggested Wire Routing for Air Compressor and Air Tank Pressure Switch

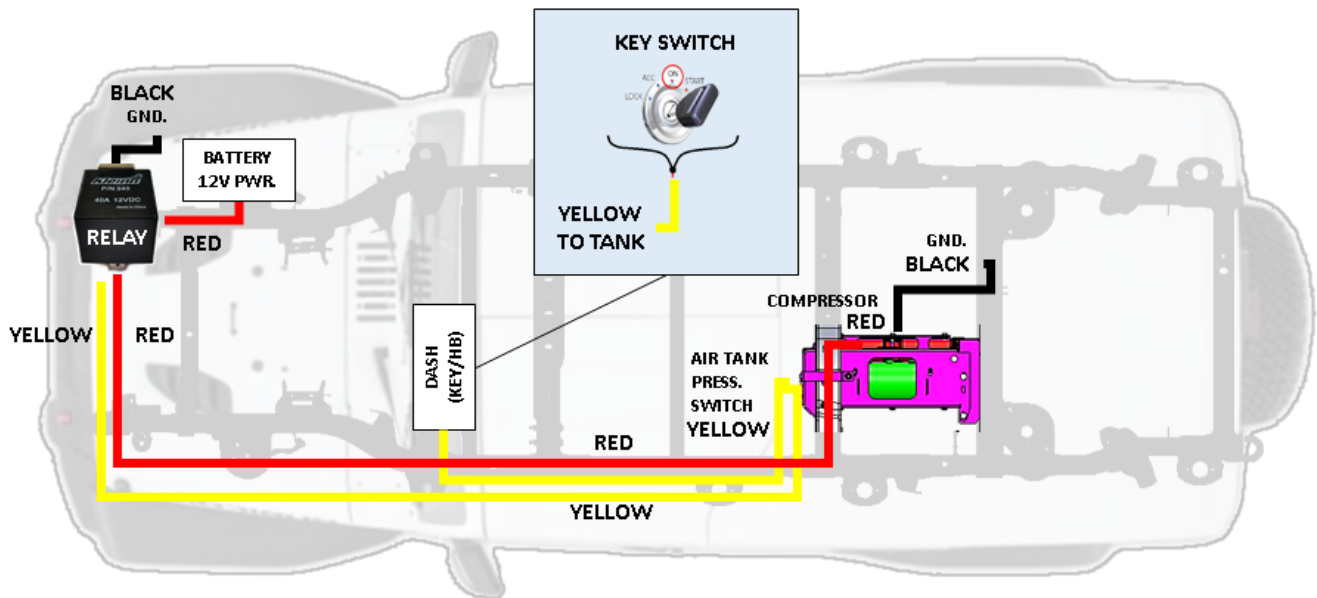

Figure 2 - Suggested Wire Routing for Air Compressor and Pressure Switch (JLU Shown)

8.3. Disconnect Vehicle Battery(s)

8.3.1. Use special care if vehicle is equipped with Auxiliary Auto Stop Battery. Consult Owner's Manual.

8.4. Connect Wiring to Relay(s) and Fuse(s), then Attach to Vehicle

8.4.1. Find a suitable location for supplied relay(s) and fuse(s). Shown below is an example location under hood next to battery and near grounding block. Use supplied self-tapping screws, as necessary.

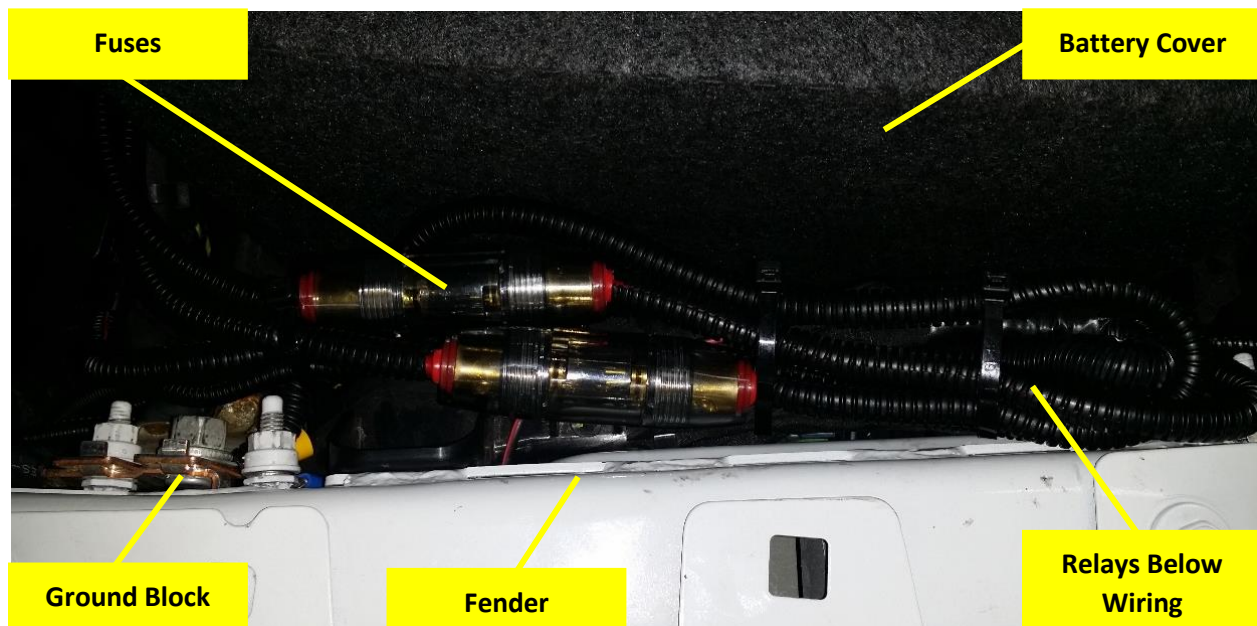



JL-JK-OBA

Installation and Operation Manual

8.5. Route Wiring

- 8.5.1. Route wiring throughout vehicle, per Figure 2 above; however, installer may route as desired.
- 8.5.2. Insert all wiring into included wire loom and ensure loom is away from all sharp edges, hot vehicle parts (i.e., exhaust, engine, radiator), and fasten securely to vehicle using zip ties, or equivalent.

NOTE: Do not cut wires to length until 100% sure of length required for final connections.

- 8.5.3. Install supplied fuse holder on end of power wire by cutting the loop in fuse holder and connecting supplied Ring terminal to one end and Butt connector to other.

CAUTION: Do not install 30-amp fuse until all electrical connections are final.

8.5.4. NOTE: FOR VEHICLES WITH FACTORY UPFITTER SWITCHES:

If your vehicle is equipped with factory upfitter (i.e., auxiliary) switches, you may elect to use them for your Kleinn Air Compressor kit; consult Owner's Manual, or dealership for further instructions on what wire terminals to use and programming required.

Shown below is example of Upfitter switches and programming on a JLU Rubicon.



End of Section



JL-JK-OBA

Installation and Operation Manual

9. Bench Assembly Steps

Complete following steps off vehicle to facilitate final installation.

NOTE: ALL HARDWARE WILL BE SPECIFIED IN INSTRUCTIONS USING ITEM NO.'S FOUND IN PARTS LIST. [See Parts List](#). Assemble ALL fasteners clean and dry using proper socket and box-end wrench. (Not including Air fittings)

9.1. Air Tank Fittings

9.1.1. Apply two small drops of [Kleinn Air Horn Juice](#) to each male pipe thread.

9.1.2. Attach air fittings to tank, per below illustration, [Click Here to View Fittings List](#)

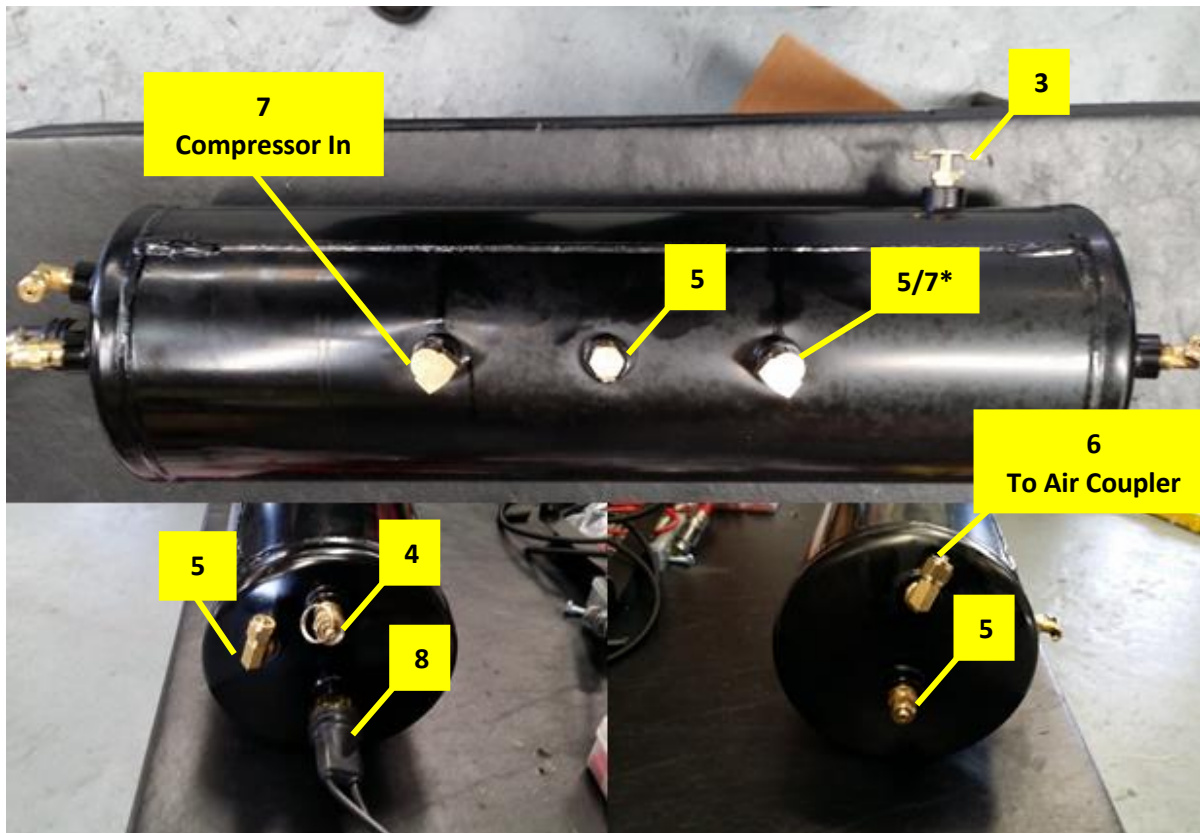

9.1.3. Hand-tighten each fitting, then further tighten each 1/4-1/2 turn using proper sized box-end wrench; adjust as necessary to match fitting orientation shown in above figure.

9.2. Attach Compressor(s) onto Skid Plate Bracket (JK-101)

9.2.1. Using [hardware](#) #9, #15, & #21 mount Compressor(s) to JK-101 with head(s) of Compressor(s) facing outwards, as shown in Figure 3 below.

9.2.2. Ensure Compressor is oriented properly, with output “leader” hose facing inward, as shown below.

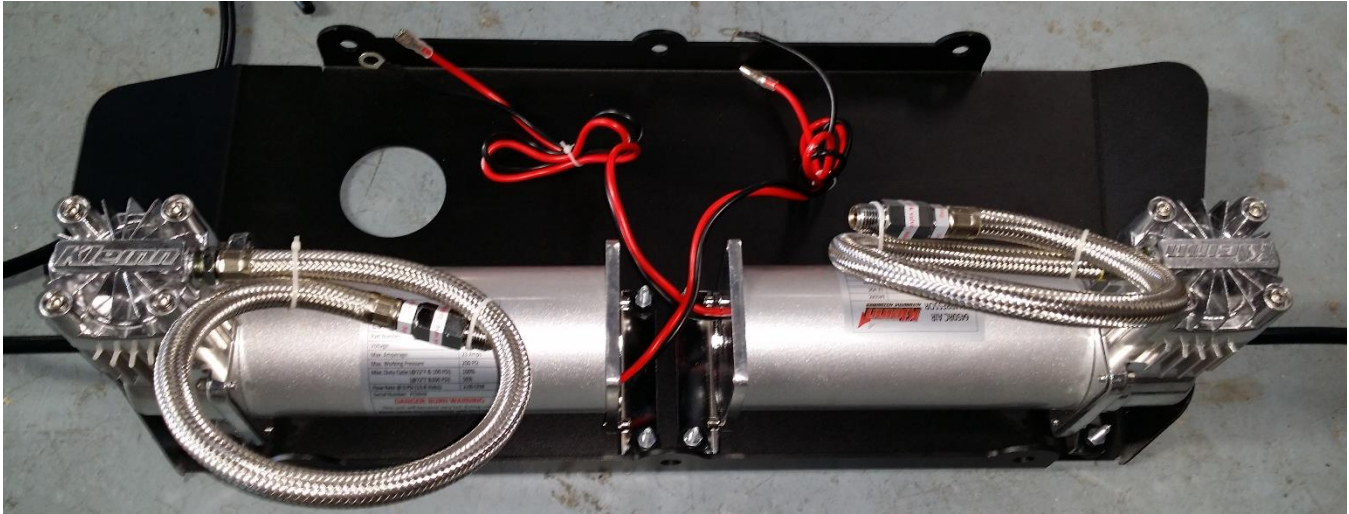

Figure 3 - Compressor Mounted onto JK-101 **JK6450 Upgrade Shown

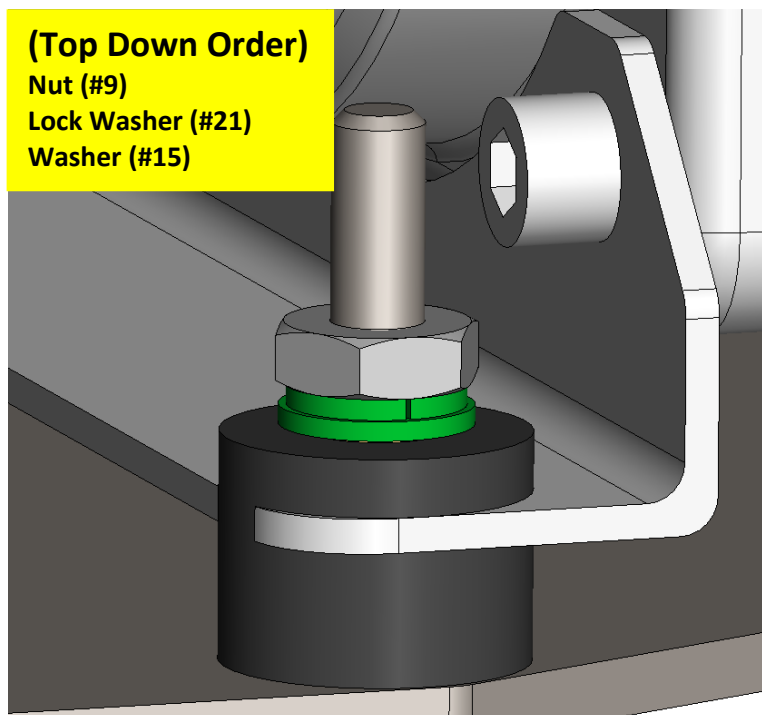

Figure 4 - Compressor Fasteners Orientation (Stack-Up)

9.2.3. Tighten all fasteners firmly, or if accurate Torque Wrench is available to 28-32 in-lbs.

9.2.4. Install Air Compressor filter(s) to each Compressor, or if preferred to mount filters remotely, attach threaded barb to front of compressor inlet.

9.2.5. To mount Air Compressor filter(s) remotely, follow instructions included in Air Compressor box.

9.3. Attach Air Tank Straps (JK-202) to Air Tank Bracket (JK-201) and Form Straps

9.3.1. Attach [hardware](#) #24 to JK-201 tank supports, as shown in Figure 5 below.

NOTE: Use a short section of tape to secure rubber if it falls off during installation process.

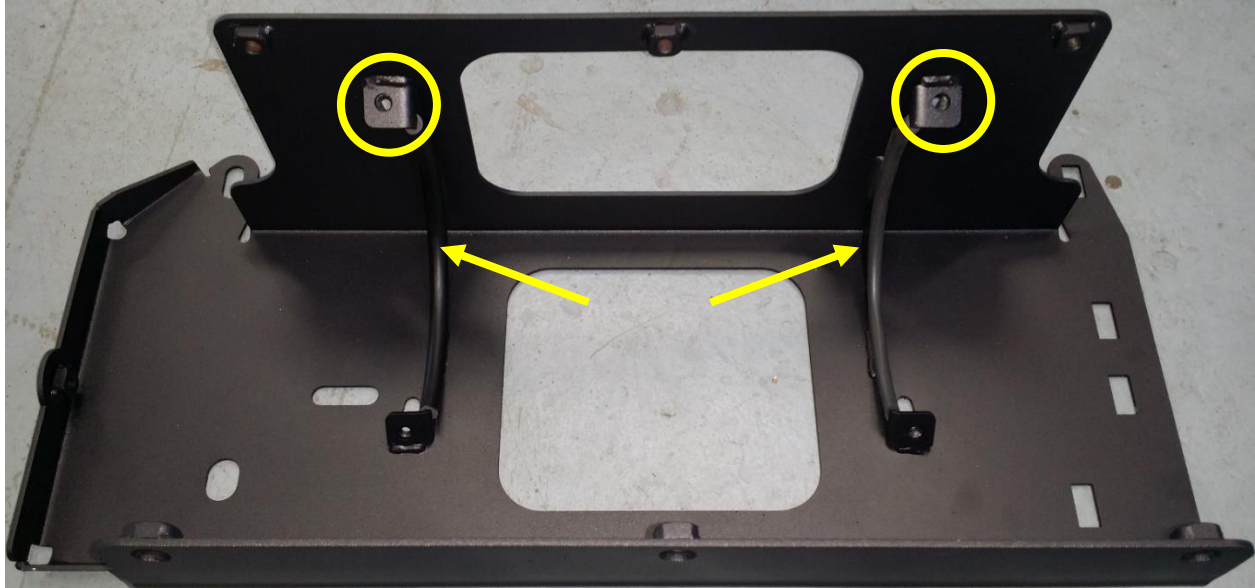

Figure 5 - Rubber Trim Attached to JK-201 (Bracket shown on bench)

9.3.2. Temporarily place Air Tank inside Tank Bracket, then attach both JK-202 Air Tank Straps to upper holes on JK-201, using [hardware](#) #1 (2), #11 (2) & #18 (2), as shown in Figure 6 below.

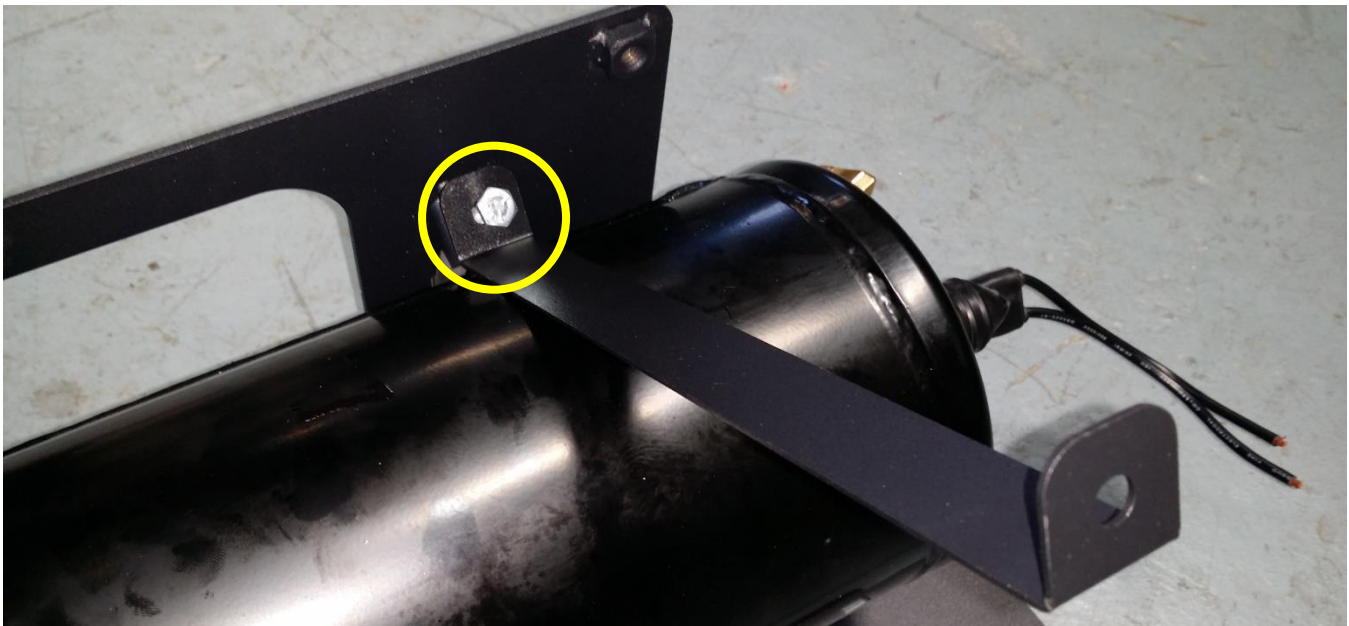

Figure 6 - JK-202 Attached to JK-201

9.3.3. Bend each JK-202 around tank, so they end up shaped round like tank, as shown in Figure 7 below.

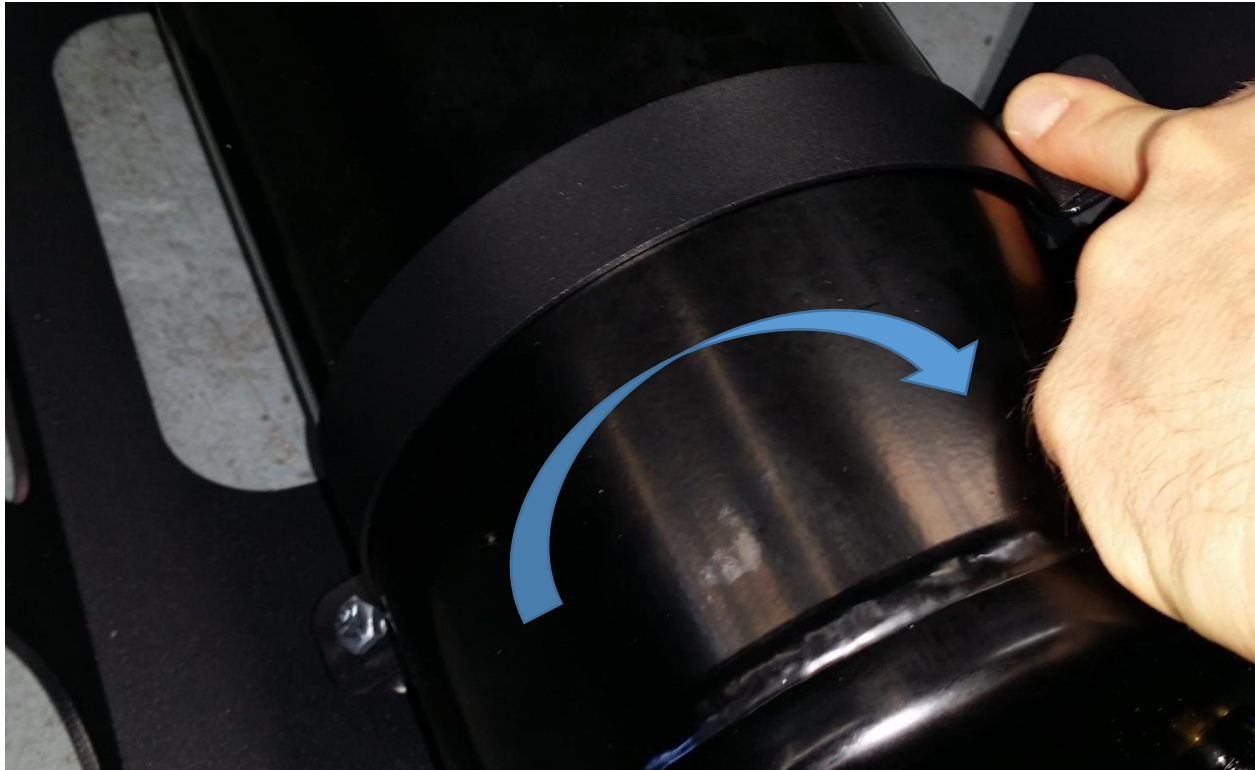

Figure 7 - JK-202 Hand Formed/Bent around Air Tank

9.3.4. Remove Air Tank from Tank Bracket, but leave Air Tank Straps attached with a single bolt each.

9.3.5. Attach [hardware](#) #25 to both JK-202, as shown in Figure 8 below.

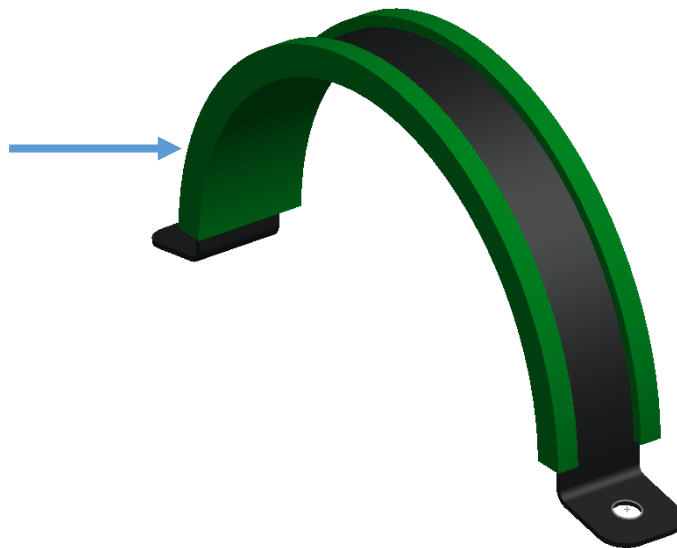

Figure 8 - JK-202 Air Tank Strap with Rubber Trim

End of Section



JL-JK-OBA

Installation and Operation Manual

10. On-Vehicle Mechanical Assembly Steps

Complete following steps *on vehicle*.

Raise vehicle off ground using appropriate vehicle lift, ramps, or jack stands.

DANGER: *Installation requires being underneath vehicle and applying forces to vehicle chassis. Follow all recommended safety precautions for raising vehicle; consult vehicle owner's manual.*

10.1. JK ONLY - Air Tank Bracket (JK-201) to Frame Installation

10.1.1. Locate factory charcoal canister in rear of vehicle, directly in front of rear coil springs on driver side.

10.1.2. Remove two (2) M8 bolts that hold front side of evaporative canister, as shown in Figure 9 below; do not discard bolts, as they will be used in later step.

- Canister will slightly hang downwards and a gap will be visible at crossmember



Figure 9 - JK-201 to Evap Canister Install

10.1.3. Insert JK-201 Tank Bracket in between frame crossmember and evaporative canister, as shown in Figure 10 below.

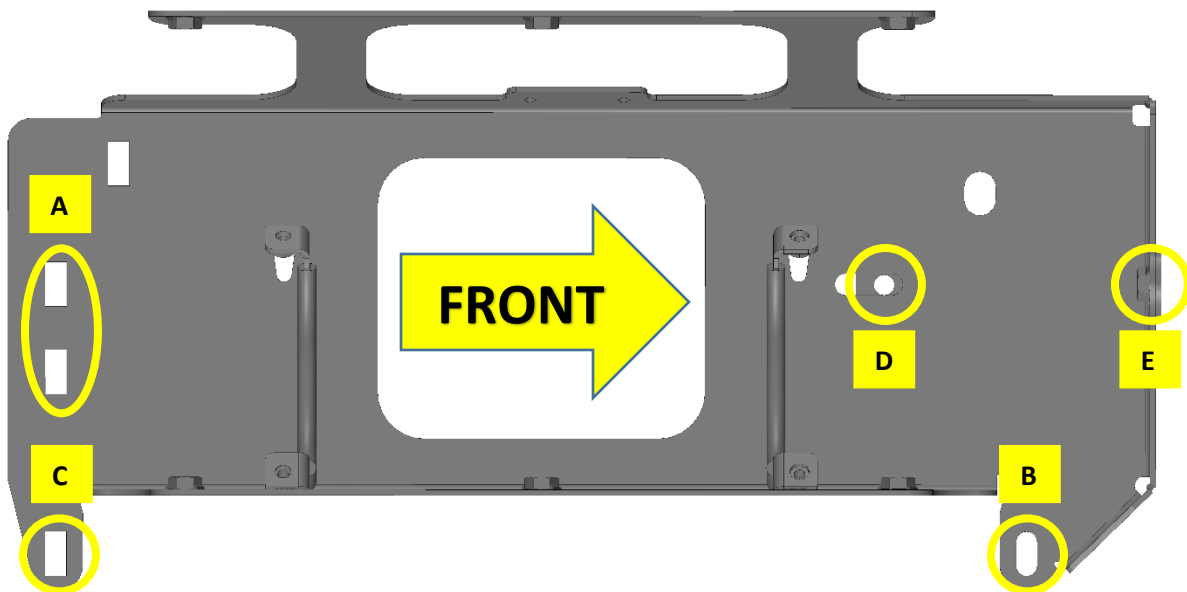
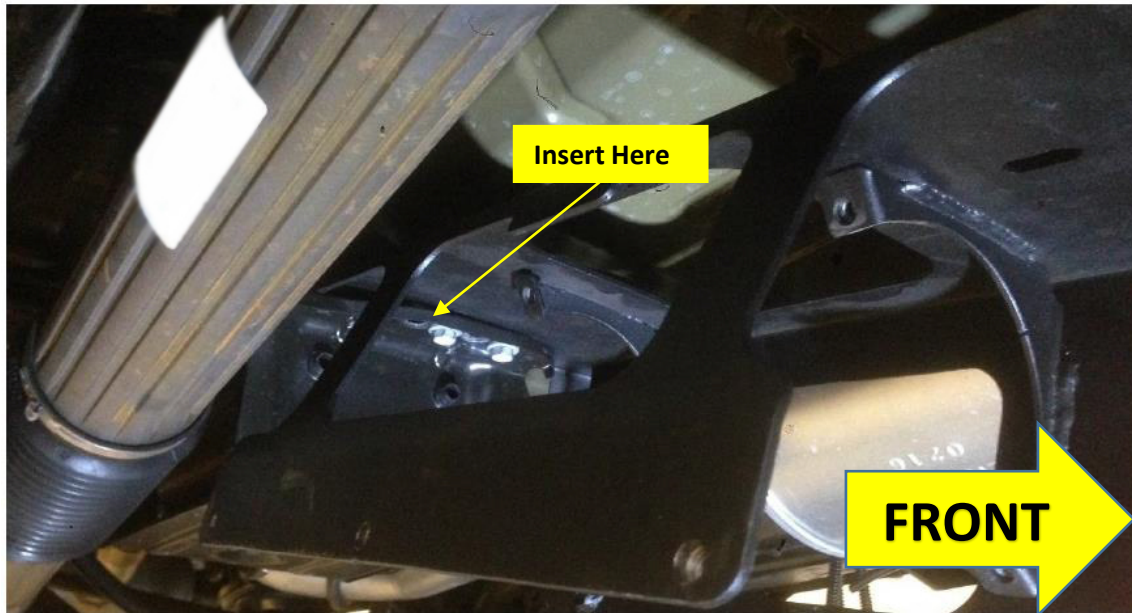

Figure 10 - JK-201 to JKU Mounting Points for Hardware

- 10.1.4. Re-install two (2) M8 bolts back into evaporative canister through JK-201 Tank Bracket at location "A", as shown in [Figure 10](#). Hand tighten.
- 10.1.5. Install [hardware](#) #4, #14 (2), #20 and #10 into front hole of JK-201 going through crossmember at location "B", as shown in [Figure 10](#). Ensure bolt is inserted from bottom with nut above crossmember; hand tighten.
- 10.1.6. Install [hardware](#) #5, #14 (2), #20 and #10 into rear hole of JK-201 going through crossmember at location "C", as shown in [Figure 10](#). Ensure bolt is inserted from bottom with nut above crossmember; hand tighten.

- 10.1.7. Install JK-203 Frame Strap over front cross member and align with JK-201, as shown in Figure 7 below; install [hardware](#) #3, #14, #20 and #10 to point “D”, as shown in [Figure 10](#). Use #2, #13, and #19 and attach to point “E”. Hand tighten.
- 10.1.8. With all fasteners hand tight, make any necessary final adjustment to position of JK201 Tank Bracket then final tighten all fasteners, using below method.

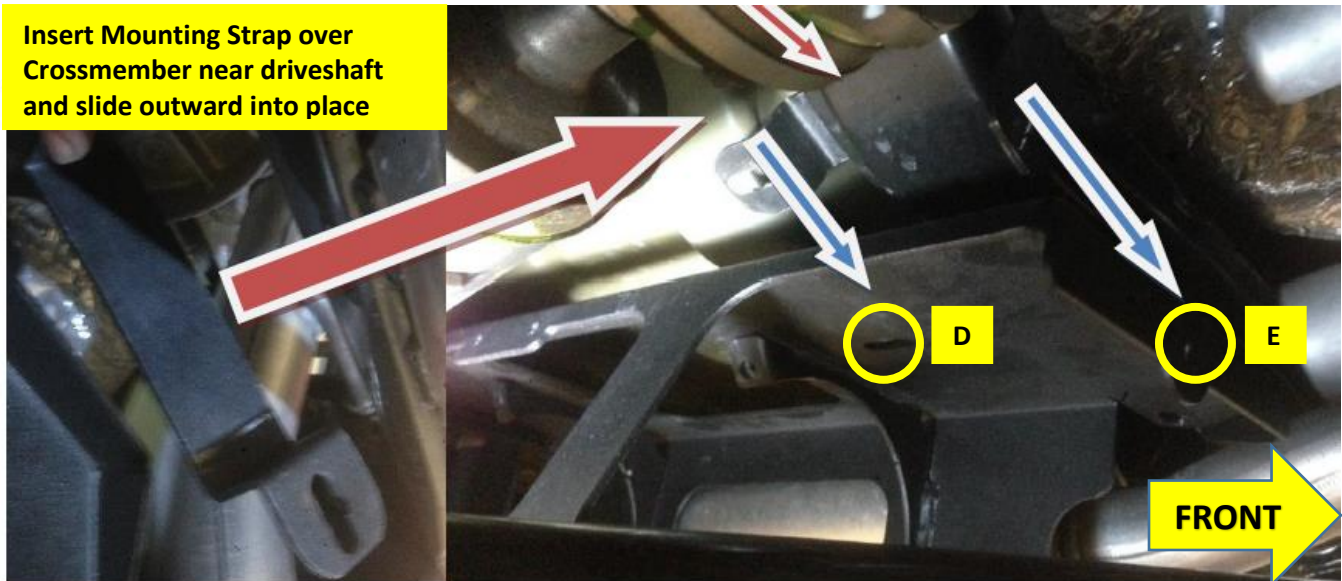

Figure 11 - JK-201 & JK-203 Mounting Strap Install over Crossmember

- 10.1.9. Firmly tighten all fasteners in following order; reference [Figure 10](#):
1. Tighten hardware “E” to 11-13 ft-lbs
 2. Tighten hardware “D” to 18-21 ft-lbs
 3. Tighten QTY (2) M8 bolts “A” connecting Evaporative Canister to 15-20 ft-lbs
 4. Tighten hardware “B” to 18-21 ft-lbs
 5. Tighten hardware “C” to 18-21 ft-lbs

10.2. **JL ONLY** - Adapter Bracket (JL-204) to Frame Installation

10.2.1. Locate two (2) metric M12 X 1.5 threaded holes on rear crossmember, in front of axle, as shown below.

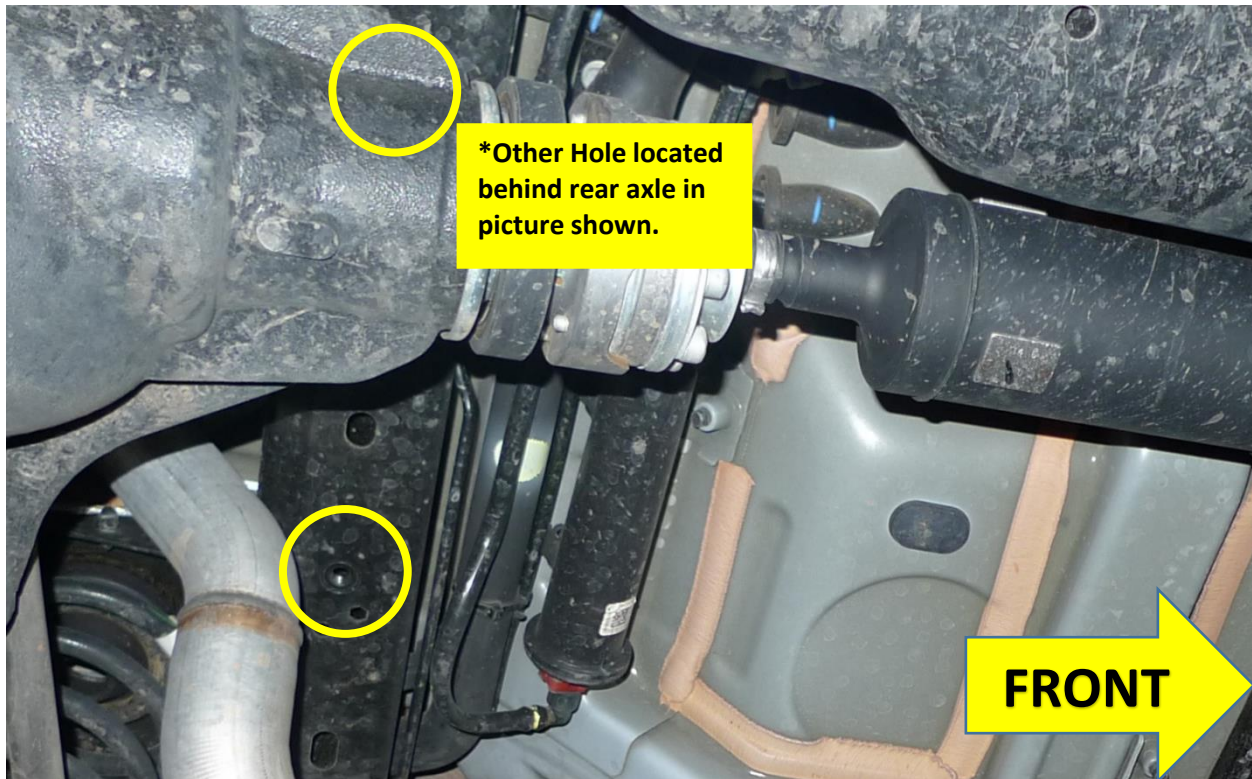

Figure 12 – JLU Rear Crossmember Mounting Locations

10.2.2. Using [hardware](#) #8, #17, & #23, install JL-204, as shown in Figure 13 below. Hand tighten only.



Figure 13 - JL-204 Adapter Bracket Bolted in Place

10.3. **JL ONLY** - Air Tank Bracket (JK-201) to Frame Installation

- 10.3.1. Remove long ground strap nut on middle crossmember, as shown circled in Figure 14 below. Do NOT discard this nut and use care when removing it to prevent stripping threads, or breaking stud.



Figure 14 – JLU Middle Crossmember & Ground Strap Mounting Point

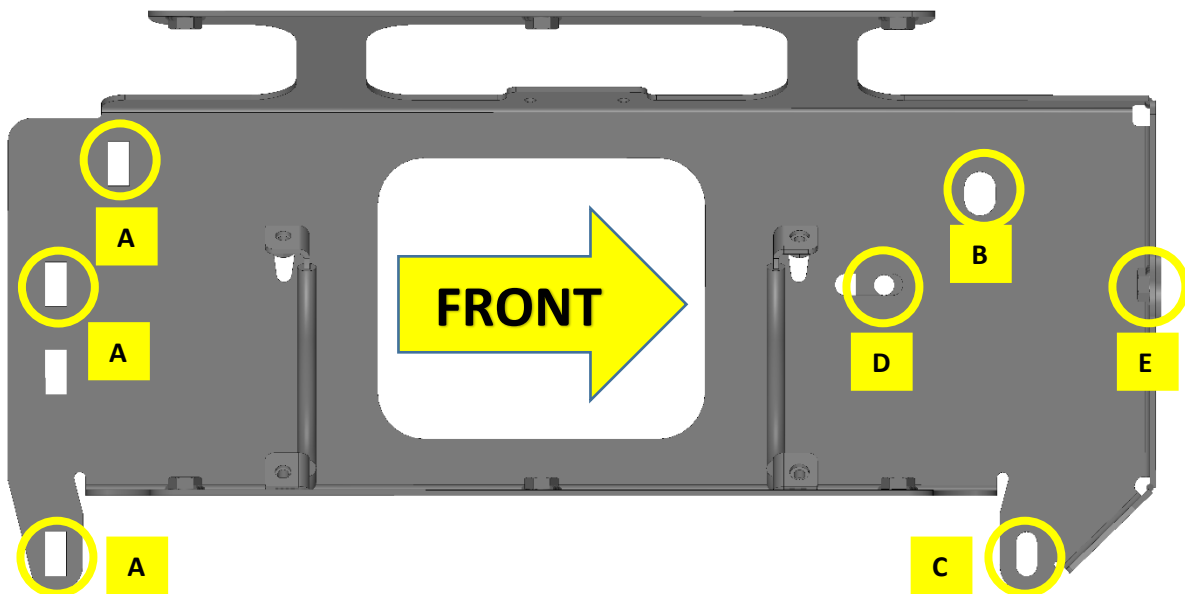

Figure 15 - JK-201 to JLU Mounting Points for Hardware

- 10.3.2. Install JK-201 on top of JL-204 and align holes “A”, as shown circled in [Figure 15](#), Figure 16, and Figure 17 below.

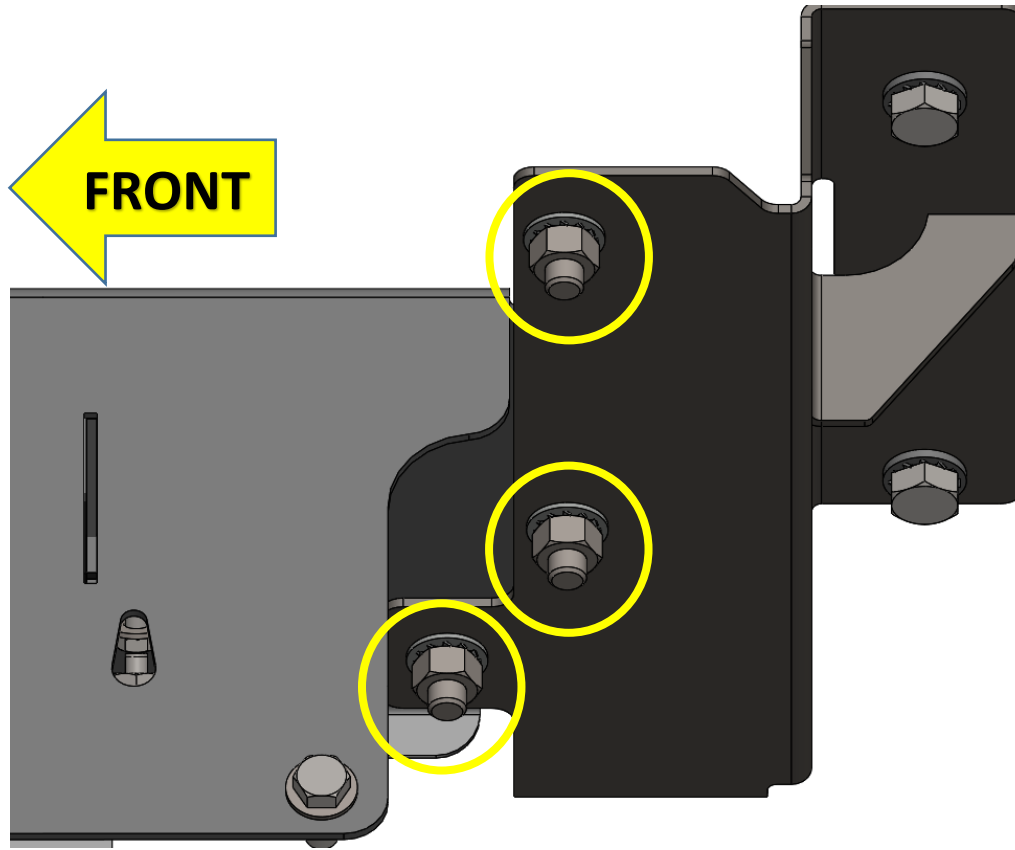

Figure 16 - JK-201 & JL-204 Hardware Attached

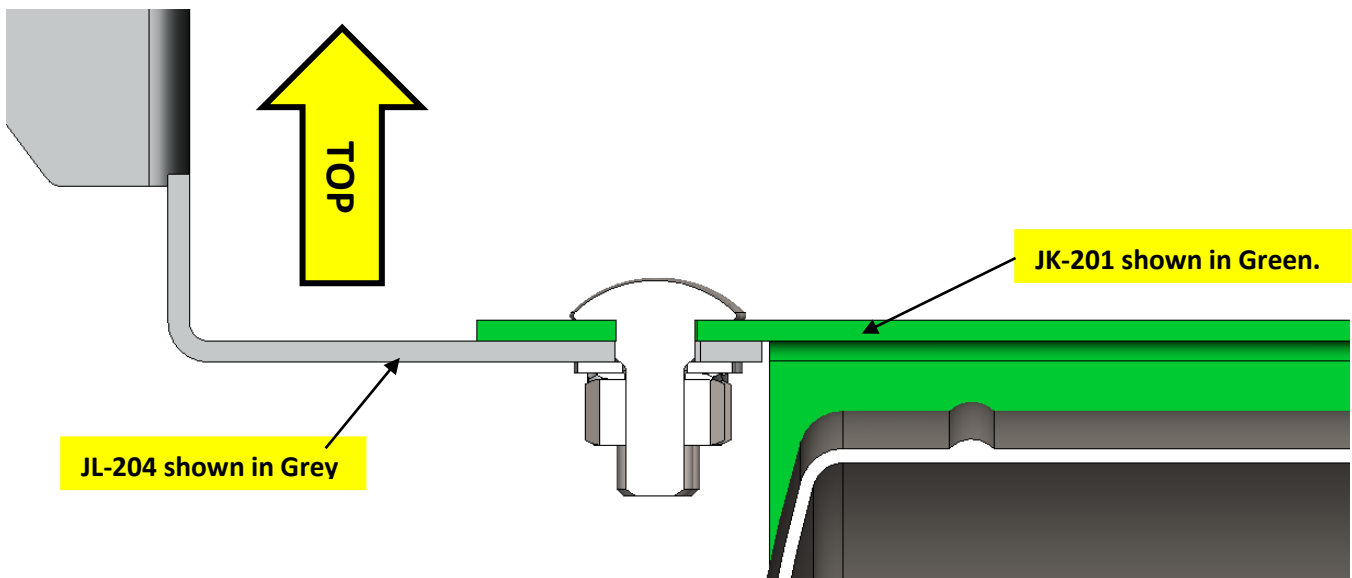

Figure 17 - JK-201 & JL-204 Section View with Hardware Stack Up

- 10.3.3. With JK-201 over Ground Strap Stud at point “B”, as shown in [Figure 15](#) above and Figure 18 below, reinstall OE nut removed using [hardware](#) #12 over bracket, as shown in Figure 19. Hand tighten.



Figure 18 – Ground Strap Nut removed; JK-201 Tank Bracket shown in place

- 10.3.4. Insert three (3) #6 facing downwards through JK-201 and JL-204 at holes “A”, as shown in [Figure 15](#).
10.3.5. Secure JK-201 & JL-204 with [hardware](#) #10, #14, & #20, as shown in Figure 16. Hand tighten fasteners.
10.3.6. Install [hardware](#) #7, #16, & #22 through hole “C”, as shown in [Figure 15](#) and below; this hole intersects a tapped hole in middle crossmember. Hand tighten.

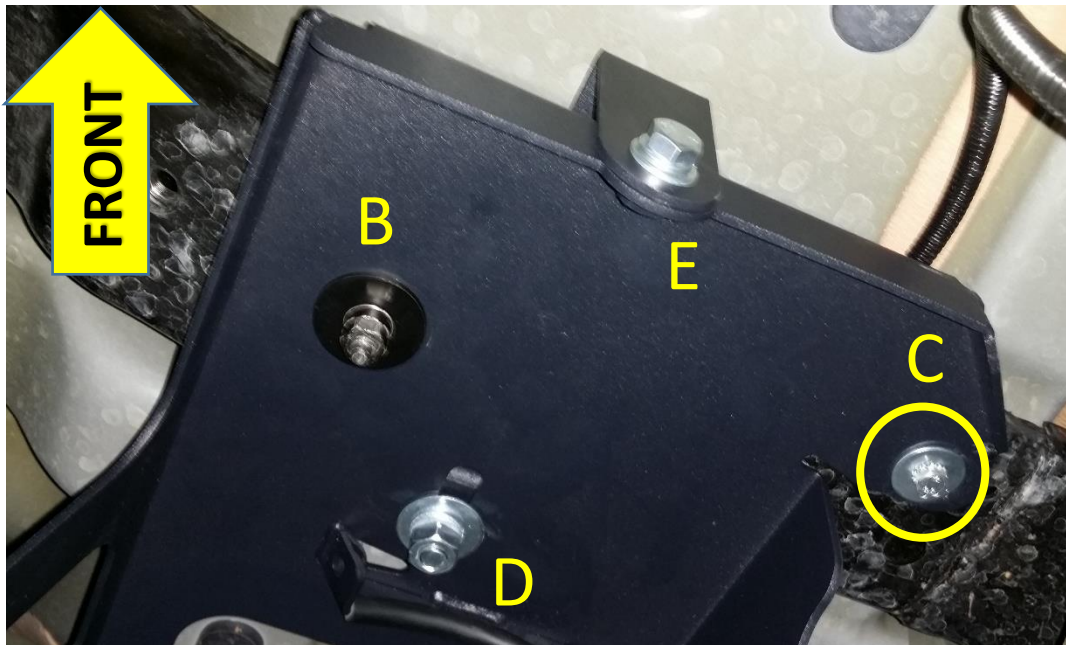

Figure 19 - JK-201 Mounting Points

- 10.3.7. Insert JL-203 Mounting Strap over JK-201 and middle crossmember; it is easiest to slide Strap over crossmember near driveshaft, then position it over correct mounting holes. Reference Figure 11 above.
- 10.3.8. Attach JL-203 strap over crossmember to hole “D”, as shown in [Figure 15](#) and Figure 19 above using [hardware](#) #6, #14, #20, and #10; hand tighten.

NOTE: If Air Tank interferes/contacts square neck bolt #6, then reverse bolt so nut is above bracket (i.e., opposite of figure 15 shown)

- 10.3.9. Attach final JL-203 Mounting Strap bolt to hole “E”, as shown in [Figure 15](#) and Figure 19 above using [hardware](#) #2, #13, and #19.
- 10.3.10. Firmly tighten all fasteners in following order; reference [Figure 15](#):
6. Tighten hardware “E” to 11-13 ft-lbs
 7. Tighten hardware “D” to 18-21 ft-lbs
 8. Tighten QTY (2) M12 bolts connecting JL-204 to rear crossmember to 25-30 ft-lbs
 9. Tighten QTY (3) square neck bolts “A” to 18-21 ft-lbs
 10. Tighten ground strap nut “B” to 75-88 in-lbs
 11. Tighten hardware “C” to 30-36 in-lbs

10.4. Air Tank to Tank Bracket Installation

- 10.4.1. Pull Air Tank Straps away as necessary and lift Air tank into position, with drain facing downwards and towards rear of vehicle, as shown in Figure 20 below.
- 10.4.2. Position Air tank so it is centered within JK-202 straps; adjust as necessary to ensure clearance between drain port and rear Tank Strap of at least 1/8”, as shown in Figure 20 below.
- 10.4.3. While holding Air Tank in place, use remaining [hardware](#) #1 (2), #11 (2) & #18 (2), to secure Air Tank to Tank Bracket. Final tighten 1/4”-20 fasteners, as shown circled in Figure 20 below to 37-43 in-lbs.

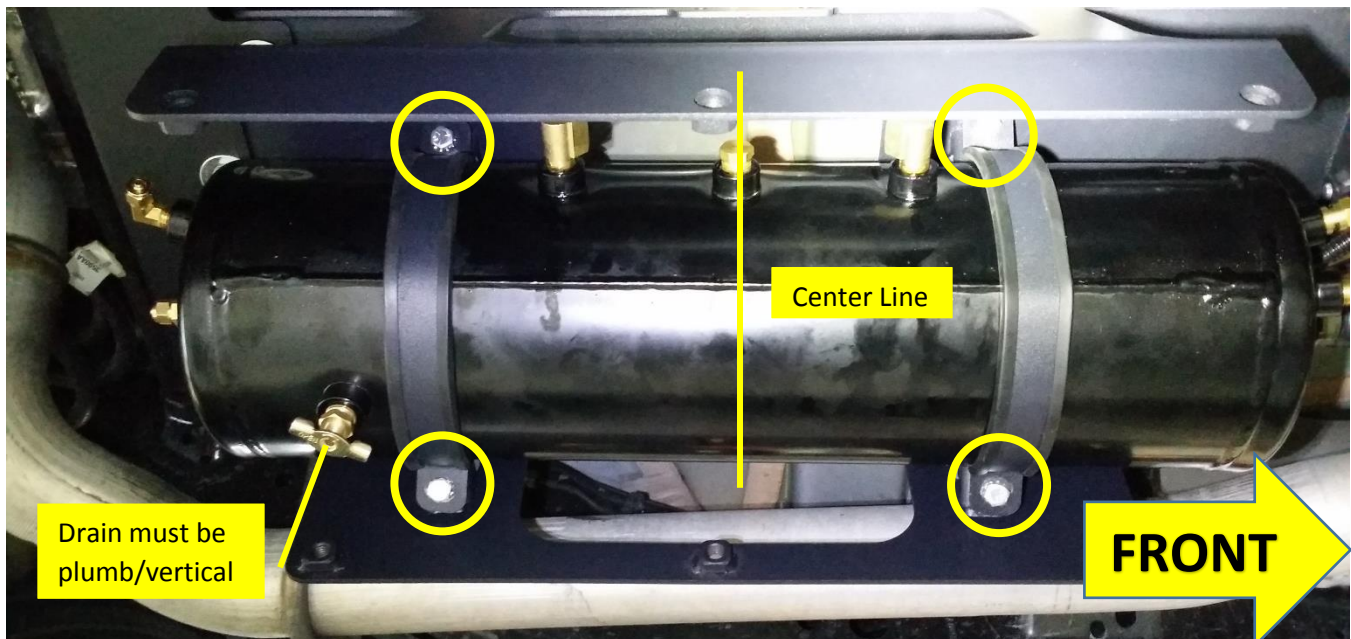

Figure 20 - Air Tank Mounted to JK-201

10.5. Skid Plate and Compressor Installation (JK-101)

10.5.1. Attach JK-101 ([Compressor Assembly](#)) to Tank Bracket and install [hardware](#) #2, #13, and #17, as shown in Figure 21 below. Tighten all fasteners to 11-13 ft-lbs.

- **NOTE:** Air tank Drain hole on JK-101 will be towards the rear of the vehicle and directly below drain valve; loosen and adjust Air Tank position if necessary to re-align position.



Figure 21 - JK-101 Mounted to Tank Bracket (Air Tank not shown)

10.6. Connect Air Compressor Leader Hose to Air Tank

10.6.1. Apply two small drops of [Kleinn Air Horn Juice](#) to male pipe thread on Compressor outlet “leader” hose and connect to [#8 fitting shown above](#). Firmly tighten.

10.6.2. Connect remote air filter to Compressor if you elected to route remote filters.

10.7. Connect Remote Quick Connect Kit to Vehicle

10.7.1. Route and attach Quick Connect Coupler Kit to vehicle, as desired using attachment bracket and self-drilling fasteners, supplied in Coupler package

10.7.2. Use supplied 1/4” tubing and attach to port shown above

Some optional locations include under hood, near grill, behind bumper, in bed rail, etc.



Figure 22 - Air Coupler Mounted To Bumper



JL-JK-OBA

Installation and Operation Manual

11. Initial Testing of Kit

11.1. Reconnect Vehicle Battery(s)

CAUTION: Before connecting vehicle battery(s), verify all wiring is properly connected and no shorts exists. Use of Multi-Meter, or Test Light is recommended to check continuity of all connections.

11.2. Test Air Compressor

- 11.2.1. Turn vehicle ignition to on position and allow compressor to fill Air Tank. Initial fill may take approximately 1.5-3 minutes; Air Compressor should shut off automatically once full pressure is achieved.
- 11.2.2. If compressor runs excessively (i.e., 5 minutes or more), disconnect electrical power to Air Compressor and listen for air leaks in system. Repair any problems and retest; contact Kleinn technical support if problem persists.
- 11.2.3. Inspect all air line connections (i.e., Air Tank fittings, Quick Connect fittings, Air Horn fittings, etc.) for leaks by using a soap and water solution sprayed directly onto fittings
- 11.2.4. System must be pressurized or at least Air Compressor running
- 11.2.5. If an air leak is found:
- 11.2.6. Safely release air pressure from system (i.e., slowly open drain valve)
- 11.2.7. Disassemble leaky connection, re-seal and reinstall fittings as needed

11.3. Test Quick Connect Coupler

- 11.3.1. Allow Air Compressor to refill tank, if needed
- 11.3.2. Attach supplied INF-1 inflator kit to Quick Connect Coupler and verify adequate air pressure is available
- 11.3.3. Test fill tires on vehicle, bicycle, etc.
- 11.3.4. Use Air Blow Gun
- 11.3.5. Use Air Impact Gun

12. General Operation of Kit

12.1. Compressor Operation

WARNING: Never operate Air Compressor above its *MAXIMUM PRESSURE RATING* (see label on body). Operation exceeding maximum pressure will damage Air Compressor and may result in Dangerous Air System failure.

- 12.1.1. Air compressor is equipped with an automatic thermal overload protection circuit, designed to protect air compressor from overheating and causing permanent damage.
- 12.1.2. Automatic thermal overload protector will automatically reset after 30 minutes.
- 12.1.3. To prevent discharge of vehicle's battery and for best performance, keep vehicle's engine running while using air compressor for any prolonged use (i.e., filling tires, using air tools, etc.).

13. Routine Maintenance

Perform following steps at least once during recommended intervals.

- 13.1. Yearly, or every 12000 miles verify all mounting fasteners are properly torqued; applying witness marks across fasteners and mounting parts is good practice to quickly ensure fasteners have not moved.
- 13.2. Yearly, or every 12000 miles remove all road grime and mud from mounting brackets and kit parts using clean water from a garden hose; pay special attention to corners where dirt may collect. Touch up all paint chips using automotive grade enamel in either spray, or brush form.

NOTE: High-pressure washers may damage part finishes and *must* be used with care. Do this more frequently if traveling regularly off-road, or in winter climates where road salts are used.



JL-JK-OBA

Installation and Operation Manual

- 13.3. Yearly, or every 12000 miles check electrical and air fitting connections and wires for abrasion, corrosion, or other damage. Replace damaged components.

NOTE: if system runs continuously or turns on unexpectedly, leaks or intermittent electrical connection may be present.

- 13.4. Monthly, or every 10 hours of compressor run time, drain moisture from air tank using drain valve installed at bottom of tank.

WARNING: *Failure to regularly drain air tank may result in corrosion inside tank and possible failure in tank or air lines, which can suddenly*

release air pressure causing injury to nearby people.

- 13.5. Yearly, or every 12000 miles clean, or replace air compressor air filter element. Replacement frequency depends on operating frequency and conditions of operating environment (i.e., daily use of air compressor in dusty, or wet environment requires more frequent filter change).

NOTE: Never lubricate or add any liquids to the included oil-less air compressor

Thank you for purchasing this JL-JK-OBA. Shall you experience any unexpected problems during installation, or have problems with any part at any time please contact Kleinn support.