



GMHD-230/734/OBA
INSTALLATION MANUAL





GMHD-230/734/OBA

Installation and Operation Manual

Table of Contents

1. LIST OF FIGURES
2. How to Use this Manual
 - 2.1. Interactive Manual using Adobe Reader (*or similar*)
 - 2.2. Your Kleinn Kit SKU Number and coverage in this Manual
 - 2.3. Illustration/Photo Details and Orientation
3. Safety First
 - 3.1. Before You Start
 - 3.2. Know these Special Callouts
4. Application Chart
 - 4.1. Direct Bolt-On Vehicle List (no-drilling)
 - 4.2. **Excluded OEM Vehicles
 - 4.3. Aftermarket Product Compatibility
5. Installation Overview
 - 5.1. Kit Layout and System Location(s)
 - 5.2. Approximate Installation Time
 - 5.3. INSTALL PROCESS OUTLINE
6. List of Tools and Supplies
 - 6.1. Standard Tool List (Required)
 - 6.2. Special Tool List (Recommended)
 - 6.3. Shop Consumables List (Recommended)
7. Parts List
 - 7.1. Confirm Kit Package Contents
 - 7.2. Pre-Packaged Electro-Mechanical Items
 - 7.3. Air Fittings and Related Items
 - 7.4. Electrical Small Components and Related Items
 - 7.5. Bolt-On Mounting Brackets & Special Hardware
 - 7.6. Hardware/Fasteners
8. On-Vehicle Electrical Installation
 - 8.1. Wiring Diagram for Relay and Solenoid Connections
 - 8.2. Wire Routing Layout
 - 8.3. Disconnect Vehicle Battery(s)
 - 8.4. Attach Relay and Fuse to Vehicle
 - 8.5. Route Wiring and Install Horn Button
 - 8.6. Connect Relay to Wiring
 - 8.7. Connect Air Horn Solenoid
 - 8.8. Pressure Switch
9. Bench Assembly Steps
 - 9.1. 2011-2019 ONLY Disassemble Air Horn Kit
 - 9.2. Assemble Fittings to Tank
 - 9.2.4. Air Tank Exploded View with Fittings
 - 9.3. Assemble Air Compressor to Bracket
10. On-Vehicle Mechanical Assembly Steps
 - 10.1. Prepare Mounting of Air Tank, and Air Compressor Brackets



GMHD-230/734/OBA

Installation and Operation Manual

- 10.2. Mount HD18-101 Air Compressor Assembly to Frame & Body
- 10.3. Mount HD18-201, Air Tank, Rear Half Bracket
- 10.4. Install Air Tank, and HD18-202 Bracket
- 10.5. Connect Air Compressor to Air Tank and Electrical
- 10.6. Connect Air Filter to Air Compressor
- 10.7. Connect Remote Quick Connect Kit to Vehicle
- 10.8. 734-KIT & 230-KIT ONLY | Prepare Mounting of Air Horn Brackets
- 10.9. Mount HD18-301, Driver Side Air Horn Bracket
- 10.10. Mount HD18-302, Passenger Side Air Horn Bracket
- 10.11. Mount HD18-303, Connector Bracket
- 10.12. Install Air Horns
- 10.13. Connect Air Horn to Air Tank
- 11. Initial Testing of Kit
 - 11.1. Reconnect Vehicle Battery(s)
 - 11.2. Test Air Compressor
 - 11.3. Test Train Horns
 - 11.4. Test Quick Connect Coupler
- 12. General Operation of Kit
 - 12.1. Compressor Operation
 - 12.2. Horn Operation
- 13. Routine Maintenance

End of Contents



GMHD-230/734/OBA

Installation and Operation Manual

1. LIST OF FIGURES

- Figure 1 - Passenger Side View Showing System Locations for all vehicles
- Figure 2 - Top View Showing Air Horn Orientation for 2007-2010 and 2011-2019 Vehicles
- Figure 3 - Ignition Relay Diagram for Air Compressor, Air Tank Pressure Switch, and Air Horn
- Figure 4 - Suggested Wire Routing for Air Compressor, Air Tank Pressure Switch, and Air Horn
- Figure 5 - Example of Relay and Fuse Mounted with Wire Loom
- Figure 6 - Air Tank, exploded views
- Figure 7 - Air Tank, assembled views
- Figure 8 - Air Compressor with HD18-101 Bracket, exploded view
- Figure 9 - HD18-101 Bracket with HD18-202 attachment bolts, exploded view
- Figure 10 - HD18-101, Passenger Side, 1st (front most) Bed-to-Frame Attachment Bolt
- Figure 11 - HD18-201, Passenger Side, 2nd Bed-to-Frame Attachment Bolt
- Figure 12 - (2011-2019 ONLY) Passenger Side, Bed Side Corner Brace, remove
- Figure 13 - HD18-101 Outer Floor Attachment Bolt, install sequence and section view
- Figure 14 - (2011-2019 ONLY) HD18-201 Outer Attachment Bolt, location
- Figure 15 - (2011-2019 ONLY) Zip Tie with Fish Line
- Figure 16 - (2011-2019 ONLY) HD18-201 Outer Attachment Bolt, insertion sequence
- Figure 17 - (2011-2019 ONLY) HD18-201 Outer Attachment Bolt, final position section view
- Figure 18 - Air Compressor Bracket Assembly, attachment points
- Figure 19 - Air Compressor Bracket Assembly, exploded view
- Figure 20 - Air Compressor Bracket Assembly, installed
- Figure 21 - HD18-201 Air Tank Bracket, attachment points
- Figure 22 - HD18-201 Air Tank Bracket, exploded view
- Figure 23 - HD18-201 Air Tank Bracket, installed
- Figure 24 - Air Tank, insertion method (Short & Long Bed)
- Figure 25 - HD18-202 Bracket, insertion method
- Figure 26 - Air Tank and Air Tank Brackets, exploded view
- Figure 27 - Air Tank Installed, (2011+ Short Bed frame shown)
- Figure 28 - Example of Air Coupler Mounted below Bumper
- Figure 29 - OE Tow Hook Bolts, remove (2011+ Frame Shown)
- Figure 30 - (2007-2010 ONLY) HD18-301 Ribbed Neck Bolt, insertion
- Figure 31 - HD18-301, Tape Bolts in place (ALL YEARS)
- Figure 32 - (2011-2019 ONLY) HD18-301, Driver Side Bracket, installed with Puzzle Piece
- Figure 33 - (2007-2010 ONLY) HD18-301, Driver Side Bracket, installed without Puzzle Piece
- Figure 34 - (2007-2010 ONLY) HD18-301, Driver Side Bracket, Ribbed Neck Bolt, installed section view
- Figure 35 - HD18-302, Passenger and HD18-301, Driver Side Brackets, installed (**Shown from below**)
- Figure 36 - (2015-2019 SILVERADOS) Small Trumpet sitting on Bumper Valance (**Shown from below**)
- Figure 37 - HD18-303 Connector Bracket, installed (**Shown from below**)
- Figure 38 - (2011-2019 ONLY) Air Horn Orientation, 734-KIT, installed (**Shown from Front w/o bumper**)
- Figure 39 - (2011-2019 ONLY) Air Horn Orientation, 230-KIT, installed (**Shown from Front w/o bumper**)
- Figure 40 - (2007-2010 ONLY) Air Horn Orientation, 734-KIT, installed (**Shown from Front w/o bumper**)
- Figure 41 - (2007-2010 ONLY) Air Horn Orientation, 230-KIT, installed (**Shown from Front w/o bumper**)

End of Figures



GMHD-230/734/OBA Installation and Operation Manual

2. How to Use this Manual

2.1. Interactive Manual using Adobe Reader *(or similar)*

It is recommended to open this digital PDF using Adobe Reader[®] to take advantage of following key features:

- **Hyperlinks** ([blue underlined text](#)) allow access to additional content via internet; click/tap to activate
- **Table of Contents** page allows easily navigating this manual; click/tap any section line to go to it
- **Bookmarks** allow quickly navigating to any section; click/tap
- **Zoom IN** on pictures by pressing “CTRL and +” at same time on PC, or pinch in on smart devices
- **Zoom OUT** on pictures by pressing “CTRL and -” at same time on PC, or pinch out on smart devices

To install Adobe Reader[®]

On PC, or Mac

2.2. Your Kleinn Kit SKU Number and coverage in this Manual

This manual covers installation, testing, and operation of following SKU numbers (i.e., “kits”)

2.2.1. **GMHD-230** (i.e., On-Board Air and 230 Train Horn Kit)

2.2.2. **GMHD-734** (i.e., On-Board Air and 730 Train Horn Kit)

2.2.3. **GMHD-OBA** (i.e., On-Board Air System only)

NOTE: Illustrations and pictures contained herein may represent only one kit part number. Where critical differences exist between kits (i.e., different parts, orientation, mounting points, etc.), additional text, or necessary graphics are provided to minimize confusion.

Parts list explicitly state kit differences with **(BOLD TEXT)** inside parenthesis, shown below part number.

2.3. Illustration/Photo Details and Orientation

This manual may use digitally created illustrations, and/or actual photos of example vehicle. These graphics may not include exact items found on your vehicle (i.e., electrical wiring, fuel lines, body panels, etc.). Illustrations typically will be missing details and are for clarity to show critical mounting locations and orientation on vehicle.



Throughout this manual yellow arrows with text reading “FRONT”, may be present over illustrations and pictures. These arrows specify direction toward front of vehicle and provide clarity to how illustration is viewed.

End of Section



GMHD-230/734/OBA

Installation and Operation Manual

3. Safety First

3.1. Before You Start

Read manual thoroughly before starting installation of this kit. Verify you have all parts listed and that you clearly understand this installation procedure. Contact Kleinn technical support for any questions.

Installation of this kit requires **moderate mechanical aptitude**; seek professional help if you're not competent using hand tools in tight uncomfortable spaces, and around possibly rusted and sharp vehicle parts.

Before starting, obtain proper tools required to perform installation correctly, adequate lighting, eye protection, hearing protection for operating train horns, and hand protection to guard against sharp edges and metal burrs, which may be present on kit parts and vehicle parts.

Throughout this manual the following words may be used; be aware of their meaning and application.

3.2. Know these Special Callouts

CAUTION: means damage could occur to vehicle, or kit parts during, or after installation

WARNING: means injury could occur to you or others, including damage to vehicle, or kit parts

DANGER: means serious injury or death could occur to you or others during installation

End of Section



GMHD-230/734/OBA Installation and Operation Manual

4. Application Chart

4.1. Direct Bolt-On Vehicle List (no-drilling)

GMHD-230/734/OBA is a direct bolt-on aftermarket product for CHEVROLET/GMC vehicles listed in below chart; every effort has been made to verify correct fitment on these vehicles in their factory, non-modified conditions.

MODEL YR	MODEL	DRIVE	ENGINE	BODY	TRIM
2007-2019	SILVERADO 2500HD	ALL	ALL	ALL**	ALL**
2007-2019	SILVERADO 3500HD	ALL	ALL	ALL**	ALL**
2007-2019	SIERRA 2500HD	ALL	ALL	ALL**	ALL**
2007-2019	SIERRA 3500HD	ALL	ALL	ALL**	ALL**

NOTE: All vehicles listed may require drilling holes for ground wires and installing switches, based on preference of installed switch locations and wire grounding points.

4.2. **Excluded OEM Vehicles

GMHD-230/734/OBA may NOT be compatible with following CHEVROLET/GMC vehicles:

- 4.2.1. All OE chassis cab frames with service boxes, or flat beds, as purchased from dealerships
- 4.2.2. All trim packages with OE mounted Snow Removal Accessories behind front bumper (i.e., snow plow attachments, PTO hydraulic connections, etc.)

NOTE: Review this manual in full before unpacking items and verify correct space and mounting locations exist with your trim package

4.3. Aftermarket Product Compatibility

4.3.1. This kit has been designed to be compatible with following products from leading manufacturers:

- Truck steps, such as Amp Research Power Steps[®], and all Body/Frame mounted running boards/bars

4.3.2. **This kit has NOT been designed** to be compatible with any of the following products:

- Custom front bumpers, grill guards/protection that utilize OE front tow hook mounting points
- Front mounted tow hitches, or hidden/behind front bumper winches
- All other front-end attachments that utilize OE front tow hook mounting points, or encroach on area behind OE front bumper, such as Skid Plates, Body Kits, etc.

NOTE: Review this manual in full before unpacking items and verify correct space and mounting locations exist with your aftermarket product(s). *To install this kit, modification to its parts, your vehicle, or aftermarket product(s) may be required.*

End of Section



GMHD-230/734/OBA Installation and Operation Manual

5. Installation Overview

5.1. Kit Layout and System Location(s)

GMHD-230/734/OBA consists of following sub-systems, located on vehicle, as follows:

ITEM	DESCRIPTION	MOUNTING LOCATION	APPROX. INSTALL TIME
1	730 Series Large, Medium, and Small Air Horns with Air Solenoid (734-KIT) 230 Series Large, Medium, and Small Air Horns with Air Solenoid (230-KIT)	Directly behind front bumper, between and below frame rails. Attached to OE tow hook bolt points, on both sides of frame.	2+ Hours
2	Air Tank, 3 Gal. (ALL)	Between Passenger bed side and outside of frame, directly behind cab. Attached to bed and frame.	4+ Hours
3	6350RC Air Compressor (230-KIT) 6450RC Air Compressor (734-KIT), (OBA-KIT)	Between Passenger bed side and outside of frame, directly behind cab. Attached to bed and frame.	1-2 Hours

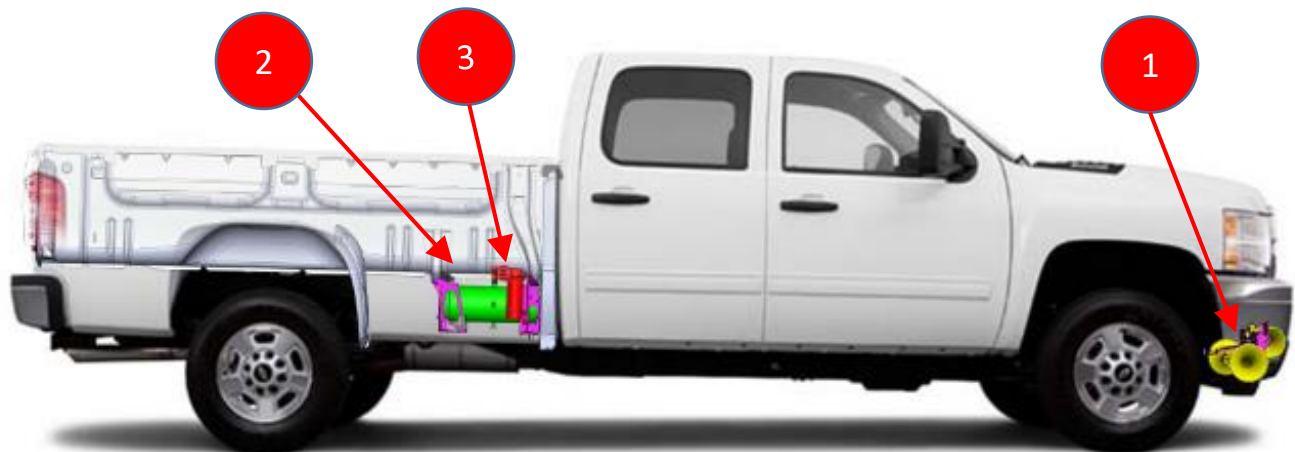

Figure 1 - Passenger Side View Showing System Locations for all vehicles

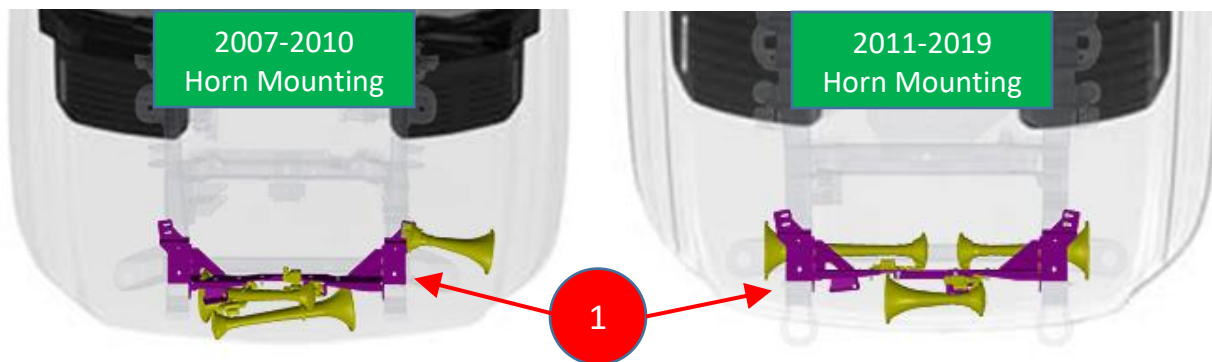

Figure 2 - Top View Showing Air Horn Orientation for 2007-2010 and 2011-2019 Vehicles



GMHD-230/734/OBA

Installation and Operation Manual

5.2. Approximate Installation Time

GMHD-230/734/OBA is a multi-faceted product consisting of multiple mechanical, electrical, and pneumatic components.

For a typical home mechanic, auto enthusiast, or technician installing a Kleinn Bolt-On kit for first time, a professional installation job with setup and testing of final product, is estimated to take:

- **6-12 Hours**
-

5.3. INSTALL PROCESS OUTLINE

GMHD-230/734/OBA can be installed using following sequence:

1. Route wiring, install Relay, and Horn Switch
2. Disassemble 230, or 730 Horn Kit
 - *i.e., separate Trumpets from Drivers, cut air lines, and remove Drivers from metal mounting plate*
3. Assemble Air Fittings to Air Tank
 - *Pre-wire and attach Air Tubing to Fittings, as clearance on vehicle may be limited*
4. Assemble Air Compressor to HD18-101 Bracket
 - *Attach Compressor Air Filter, or remote filter Air Fitting (i.e., 1/4" Barb fitting first)*
5. Mount HD18-101 Bracket and Compressor Assembly to frame & body
6. Mount HD18-201 Bracket to frame & body
7. Install Air Tank to HD18-101, HD18-201, and HD18-202 Brackets
8. Mount HD18-301 (Driver), HD18-302 (Passenger), and HD18-303 (Connector) Brackets to frame
 - *2015-2019 SILVERADO ONLY: Rest Small Trumpet on inside of front bumper before attaching HD18-303 Bracket (i.e., not possible to insert Small Trumpet with Connector Bracket in place)*
9. Install Air Horns Drivers to Horn Brackets, attach Trumpets, position, and tighten
 - *2007-2010 ALL: Insert All Air Horns whole (i.e., Trumpets attached to Drivers)*
10. Route Air Tubing, Quick Connect Coupler, Air Compressor filter, and connect all Pneumatic components
11. Test System and adjust, as needed

End of Section



GMHD-230/734/OBA

Installation and Operation Manual

6. List of Tools and Supplies

6.1. Standard Tool List (Required)

- 6.1.1. Basic mechanic's 3/8" drive socket sets with extensions
 - Inch Size Sockets (1/4" – 1" Hex)
 - Metric Size Sockets (6mm – 20mm Hex)
- 6.1.2. Basic mechanic's 3/8" socket swivel/UV-Joint
- 6.1.3. Basic mechanic's combination wrenches (box/open-end) – Ratcheting preferred
 - Inch Size Wrenches (1/4" – 1" Hex)
 - Metric Size Wrenches (6mm – 20mm Hex)
- 6.1.4. Basic mechanic's hex wrench/hex driver set
 1. Inch Size Hexes (1/8" – 1/4")
 2. Metric Size Hexes (4mm – 8mm)
- 6.1.5. Basic mechanic's screwdriver set (Philips, Flat Head)
- 6.1.6. Diagonal Cutter/Wire Cutter Pliers
- 6.1.7. Wire Strippers
- 6.1.8. Wire Terminal Crimpers
- 6.1.9. Slip-Joint Pliers (i.e., Channel Locks)
- 6.1.10. Needle Nose Pliers
- 6.1.11. Utility Knife, or Utility Razor blade

6.2. Special Tool List (Recommended)

- 6.2.1. 10-100 ft.-lb. torque wrench
- 6.2.2. 20-150 in.-lb. torque wrench
- 6.2.3. Multi-Meter for 12V DC electrical systems, or equivalent
- 6.2.4. 12V DC Test Light, or equivalent
- 6.2.5. Trim Panel Tool, for removing wiring push pins
- 6.2.6. Torch/Heat Gun for heating bolts with OE Thread Locker
- 6.2.7. Pick, or small hook tool for working through blind hole
- 6.2.8. Extendable Magnetic tool, 1/4" diameter max

6.3. Shop Consumables List (Recommended)

- 6.3.1. Quality Electrical tape
- 6.3.2. Di-electric grease for electrical connections
- 6.3.3. Silicone grease, or equivalent for rubber compressor bushings
- 6.3.4. Heat Shrink tubing for electrical connections
- 6.3.5. Medium-Strength Loctite (i.e., Blue Loctite PN 242), or equivalent
- 6.3.6. Sand Paper, or Wire Brushes for installing ground wires
- 6.3.7. Extra plastic zip ties > 6" long
- 6.3.8. Extra NPT sealant (i.e., Kleinn Air Horn Juice, Teflon tape, etc.)
- 6.3.9. Touch-up paint for frame/chassis
- 6.3.10. Typical cleanup supplies

End of Section



GMHD-230/734/OBA

Installation and Operation Manual

7. Parts List

7.1. Confirm Kit Package Contents

Unpackage and organize Kit across a large work area and verify all parts are included, as listed below. Contact Kleinn support if any questions arise ([click to email](#), [click to call](#)).

- Review pre-packaged items (i.e., train horn box, air compressor, air tank, etc.)
- Review Air Fittings and Tubing
- Review Wiring and Accessories
- Review Bolt-On Mounting Brackets
- Review Hardware/Fasteners

7.2. Pre-Packaged Electro-Mechanical Items

NOTE: Items in this section come in their own packages and may include additional items, or hardware inside



ITEM	QTY	PART NUMBER	DESCRIPTION	PICTURE
K1	1	6350RC (230-KIT ONLY)	6350RC Compressor Kit, with included hardware, connection hose, and remote Air Filter connections and tubing	
K1	1	6450RC (734-KIT ONLY) (OBA-KIT ONLY)	6450RC Compressor Kit, with included hardware, connection hose, and remote Air Filter connections and tubing	
K2	1	230 (230-KIT ONLY)	230 Series Horn Kit, with included solenoid/valve, and 1/4" Air Tubing, 15 ft. long	
K2	1	730 (734-KIT ONLY)	730 Series Horn Kit, with included solenoid/valve, and 1/2" Air Tubing, 15 ft. long	



GMHD-230/734/OBA

Installation and Operation Manual

7.3. Air Fittings and Related Items

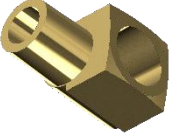
ITEM	QTY	PART NUMBER	DESCRIPTION	PICTURE
F1	1	6350RT	Air Tank, 7" OD X 21" L, 3 Gal., 7-Port	
F2	1	52835 (view location on Air Tank)	1/4" NPT, Drain Valve	
F3	1	52175 (view location on Air Tank)	1/4" NPT, 175 PSI Safety Valve	
F4	1	50041 (view location on Air Tank)	1/4" NPT Hex Plug	
F5	1	51414L (view location on Air Tank)	1/4" NPT X 1/4" Compression Fitting, 90 Deg Elbow	
F6	2	59014 (view location on Air Tank)	1/4" NPT X 1/4" NPT, 90 Deg Elbow. Male to Female.	
F7	1	2151 (view location on Air Tank)	1/4" NPT Pressure Switch	



GMHD-230/734/OBA



Installation and Operation Manual

F8	1	51214R (view location on Air Tank)	1/2" NPT X 1/4" NPT Reducer Fitting	
F9	1	51214L (view location on Air Tank) (734-KIT ONLY)	1/4" NPT X 1/2" Tube Fitting, 90 Deg. Elbow, Male to Female	
F9	1	51414L (view location on Air Tank) (230-KIT ONLY) (OBA-KIT ONLY)	1/4" NPT X 1/4" Tube Fitting, 90 Deg. Elbow, Male to Female	
F10	1	PFT4-A	1/4" Air Tubing, 5 ft. long (for connecting Air Horns to each other)	
F11	1	PFT4-A (230-KIT ONLY) (OBA-KIT ONLY)	1/4" Air Tubing, 26 ft. long (for connecting Air Horns to Air Tank, or Dash Gauge)	
F11	1	PFT2-A (734-KIT ONLY)	1/2" Air Tubing, 25 ft. long (for connecting Air Horns to Air Tank)	
F12	1	1302L	Quick Connect Air Coupler Kit, with relocation bracket, and 1/4" Air Tubing, 12 ft. long	







GMHD-230/734/OBA

Installation and Operation Manual

F13	1	1301L (OBA-KIT ONLY)	Dash Gauge kit with installation bracket, and 1/4" Air Tubing, 12 ft. long	
F14	1	INF-1	Inflator Kit, with Air Hose and Bag	
F15	1	KLEINN AIR HORN JUICE	Thread Sealant for NPT Fittings	

7.4. Electrical Small Components and Related Items

ITEM	QTY	PART NUMBER	DESCRIPTION	PICTURE
E1	1	320 (734-KIT ONLY) (230-KIT ONLY)	Terminator – Nickel Plated Remote Horn Button	
E2	1	WIRE KIT	Full Wire Kit, with electrical connectors, relay, fuse and zip ties	
E3	1	3/8" WIRE LOOM X 3 FT. LONG	3/8" WIRE LOOM, CORRUGATED AND SPLIT	
E4	1	1/4" WIRE LOOM X 3 FT. LONG	1/4" WIRE LOOM, CORRUGATED AND SPLIT	
E5	1	1/8" WIRE LOOM X 3 FT. LONG	1/8" WIRE LOOM, CORRUGATED AND SPLIT	



GMHD-230/734/OBA

Installation and Operation Manual

7.5. Bolt-On Mounting Brackets & Special Hardware

ITEM	QTY	PART NUMBER	DESCRIPTION	PICTURE
M1	1	HD18-101 (go to install section)	COMPRESSOR BRACKET, WELDMENT	
M2	1	HD18-201 (go to install section)	TANK BRACKET, REAR HALF, WELDMENT	
M3	1	HD18-202 (go to install section)	TANK BRACKET, FRONT HALF, CUT & FORMED	
M4	1	HD18-301 (go to install section) (734-KIT ONLY) (230-KIT ONLY)	HORN BRACKET, DRIVER SIDE, WELDMENT <i>(WITH PUZZLE PIECE)</i>	
M5	1	HD18-302 (go to install section) (734-KIT ONLY) (230-KIT ONLY)	HORN BRACKET, PASSENGER SIDE, WELDMENT <i>(WITH PUZZLE PIECE)</i>	
M6	1	HD18-303 (go to install section) (734-KIT ONLY) (230-KIT ONLY)	HORN BRACKET, CONNECTOR, WELDMENT	



GMHD-230/734/OBA

Installation and Operation Manual

7.6. Hardware/Fasteners

ITEM NO.	QTY.	HARDWARE SIZE	DESCRIPTION	WHERE USED
H1	4	1/4"-20 X 1"	SQUARE NECK BOLT, GRADE 2, ZINC-PLATED	ORE MOUNT (4)
H2	6	1/4" ID X 0.63" OD	FLAT WASHER, SAE, ZINC-PLATED	ORE MOUNT (4) COMPRESSOR BRACKET (2)
H3	5	1/4"	LOCK WASHER, SPLIT, ZINC-PLATED	ORE MOUNT (4) COMPRESSOR BRACKET (1)
H4	5	1/4"-20	HEX NUT, GRADE 2, ZINC-PLATED	ORE MOUNT (4) COMPRESSOR BRACKET (1)
H5	1	1/4"-20 X 1" LONG	BUTTON HEAD CAP SCREW, ZINC-PLATED	COMPRESSOR BRACKET (1)
H6	20	5/16"-18 X 1.25" LONG	SQUARE NECK BOLT, GRADE 2, ZINC-PLATED	HORN DRIVERS (6) HORN BRACKETS (6) AIR TANK (4) COMPRESSOR BRACKET (4)
H7	4	5/16"-18 X 1" LONG	KNURLED CARRIAGE BOLT, GRADE 2, ZINC-PLATED	HORN BRACKET (2) TANK BRACKET (1) COMPRESSOR BRACKET (1)
H8	2	5/16"-18 X 1" LONG	BUTTON HEAD CAP SCREW, ZINC-PLATED	TANK BRACKET (1) COMPRESSOR BRACKET (1)
H9	28	5/16" ID X 0.88" OD	FLAT WASHER, USS, ZINC-PLATED	HORN DRIVERS (6) HORN BRACKET (8) TANK BRACKET (2) AIR TANK (4) COMPRESSOR BRACKET (8)
H10	25	5/16"	LOCK WASHER, SPLIT, ZINC-PLATED	HORN DRIVERS (6) HORN BRACKET (8) TANK BRACKET (1) AIR TANK (4) COMPRESSOR BRACKET (6)
H11	1	5/16" ID X 1.25" OD	FLAT WASHER, FENDER, ZINC-PLATED	COMPRESSOR BRACKET (1)
H12	2	8.4MM ID X 24MM OD	METRIC FLAT WASHER, FENDER, ZINC-PLATED	TANK BRACKET (1) COMPRESSOR BRACKET (1)
H13	25	5/16"-18	HEX NUT, GRADE 2, ZINC-PLATED	HORN DRIVERS (6) HORN BRACKET (8) TANK BRACKET (1) AIR TANK (4) COMPRESSOR BRACKET (6)
H14	4	#10 ID X .69" OD	FLAT WASHER, FENDER, ZINC-PLATED	COMPRESSOR BRACKET (4)
H15	1	-	14" LARGE PLASTIC ZIP TIE WITH 3 FT OF FISH LINE	TANK BRACKET BOLT INSERTION (2011+ VEHICLES ONLY)

8. On-Vehicle Electrical Installation

CAUTION: Follow all recommended safety precautions for working on vehicle's electrical system; consult vehicle owner's manual for further instruction.

8.1. Wiring Diagram for Relay and Solenoid Connections

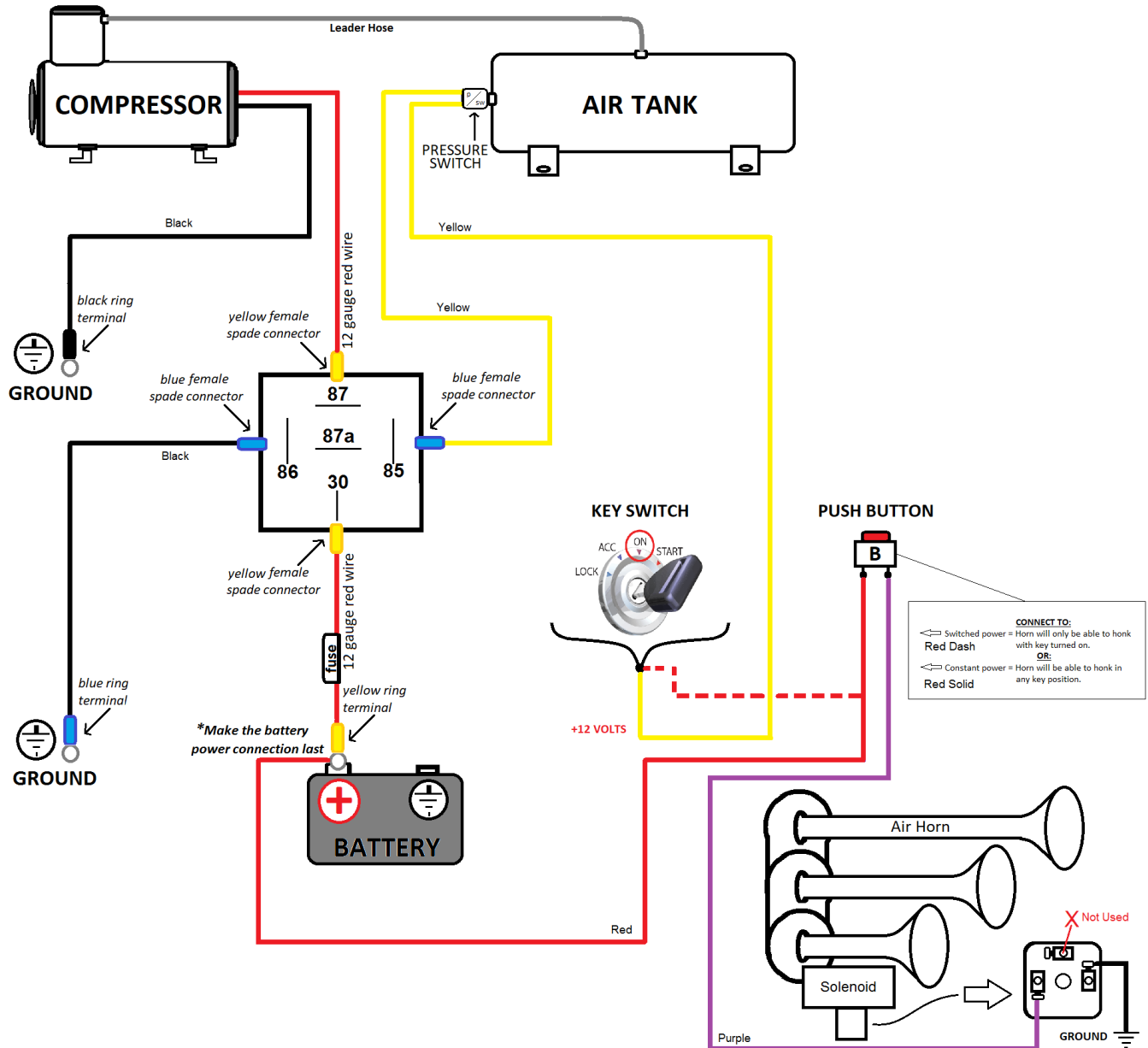

Figure 3 - Ignition Relay Diagram for Air Compressor, Air Tank Pressure Switch, and Air Horn

8.2. Wire Routing Layout

GMHD-230/734/OBA KIT

RECOMMENDED WIRE ROUTING

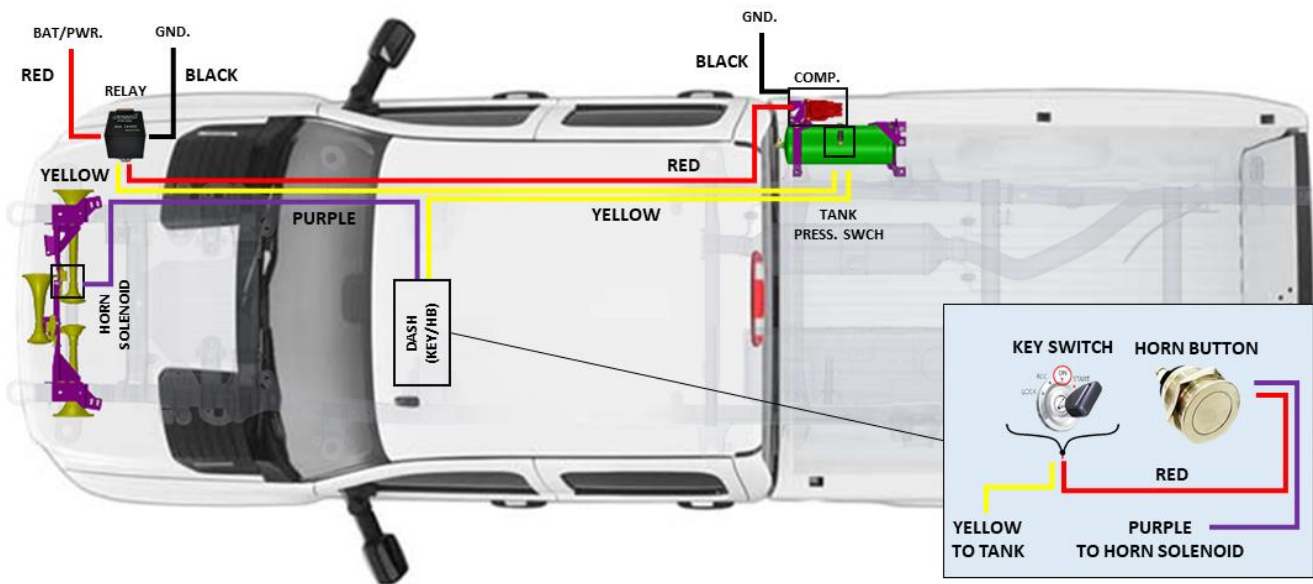

Figure 4 - Suggested Wire Routing for Air Compressor, Air Tank Pressure Switch, and Air Horn

8.3. Disconnect Vehicle Battery(s)

8.4. Attach Relay and Fuse to Vehicle

- 8.4.1. Select an area under hood as close to battery/power supply block as possible, to attach relay and inline fuse to body using supplied self-tapping screws. It is recommended to attach relay ground to a factory ground bolt/ground block, to minimize drilling holes. Reference wiring figures above.

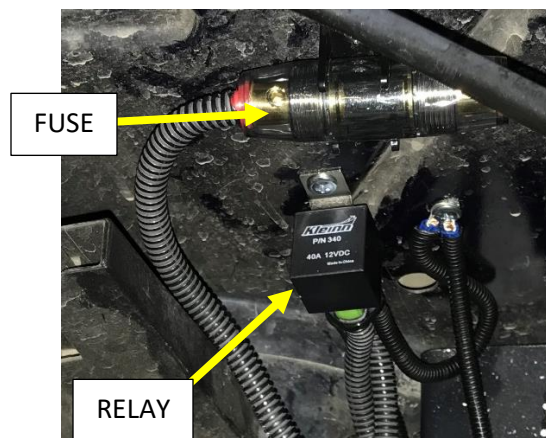

Figure 5 - Example of Relay and Fuse Mounted with Wire Loom



GMHD-230/734/OBA

Installation and Operation Manual

8.5. Route Wiring and Install Horn Button

- 8.5.1. Route wiring throughout vehicle, per above diagrams; however, installer may route as desired.
- 8.5.2. Insert all wiring into included wire loom and ensure loom is away from all sharp edges, hot vehicle parts (i.e., exhaust, engine, radiator), and fasten securely to vehicle using zip ties, or equivalent.
NOTE: Do not cut wires to length until 100% sure of length required for final connections.
- 8.5.3. Install supplied fuse holder on end of power wire by cutting the loop in fuse holder and connecting supplied Ring terminal to one end and Butt connector on other end.
CAUTION: Do not install 30-amp fuse until all electrical connections are final.
- 8.5.4. Find a suitable location for horn push-button (i.e., in dash, center console, etc.); verify location has 1"+ of clearance behind for terminal connectors. Mark location for drilling.



NOTE: FOR VEHICLES WITH FACTORY UPFITTER SWITCHES:

If your vehicle is equipped with factory upfitter (i.e., auxiliary) switches, you may elect to use them for your Kleinn Air Horn kit; consult Owner's Manual, or dealership for further instructions on what wire terminals/fuse block location to use and programming required.

- 8.5.5. Drill a 3/4" hole at location. Route horn button wires to hole then slide push-button retaining nut over wires and connect wiring. Install push-button into hole and tighten retaining nut from backside.
- 8.6. **Connect Relay to Wiring**
- 8.6.1. Connect routed wiring to relay, per wiring diagram. [See Figure 3](#)
- 8.7. **Connect Air Horn Solenoid**
- 8.7.1. Vehicle space constraints make it difficult to connect Air Horn Solenoid in-vehicle; therefore, it is recommended to cut and connect a section of wiring to Solenoid during bench assembly, then perform final connection once Air Horn assembly is installed.
- 8.8. **Pressure Switch**
- 8.8.1. Vehicle space constraints make it difficult to connect pressure switch in-vehicle; therefore, it is recommended to cut and connect a section of wiring to pressure switch during bench assembly, then perform final connection once Air Tank is installed in vehicle.

End of Section



GMHD-230/734/OBA Installation and Operation Manual

9. Bench Assembly Steps

Complete following steps off vehicle to facilitate final installation.

NOTE: ALL HARDWARE WILL BE SPECIFIED IN INSTRUCTIONS USING ITEM NO.'S FOUND IN [PARTS LIST](#).

9.1. 2011-2019 ONLY Disassemble Air Horn Kit

9.1.1. Unpackage and fully disassemble Air Horn kit; train horns must be separated for individual installation to Brackets (i.e., unthread Trumpets from Drivers, unbolt Drivers from metal mounting bar, cut lines).

9.2. Assemble Fittings to Tank

9.2.1. Apply two small drops of [Kleinn Air Horn Juice](#) to each male pipe thread.

9.2.2. Attach air fittings to tank, per illustrations.

9.2.3. Hand-tighten each fitting, then further tighten each 1/4-1/2 turn using proper sized box-end wrench; adjust as necessary to match fitting orientation shown.

9.2.4. [Air Tank Exploded View with Fittings](#)

[Return to Fittings List](#)

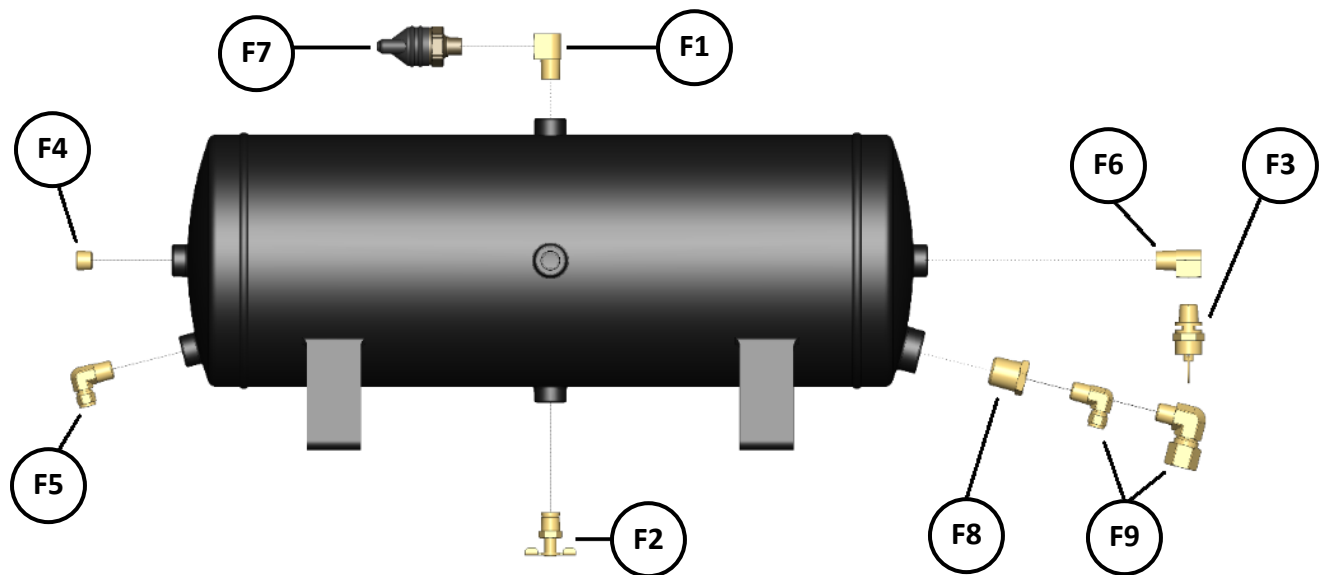

Figure 6 - Air Tank, exploded views



GMHD-230/734/OBA

Installation and Operation Manual

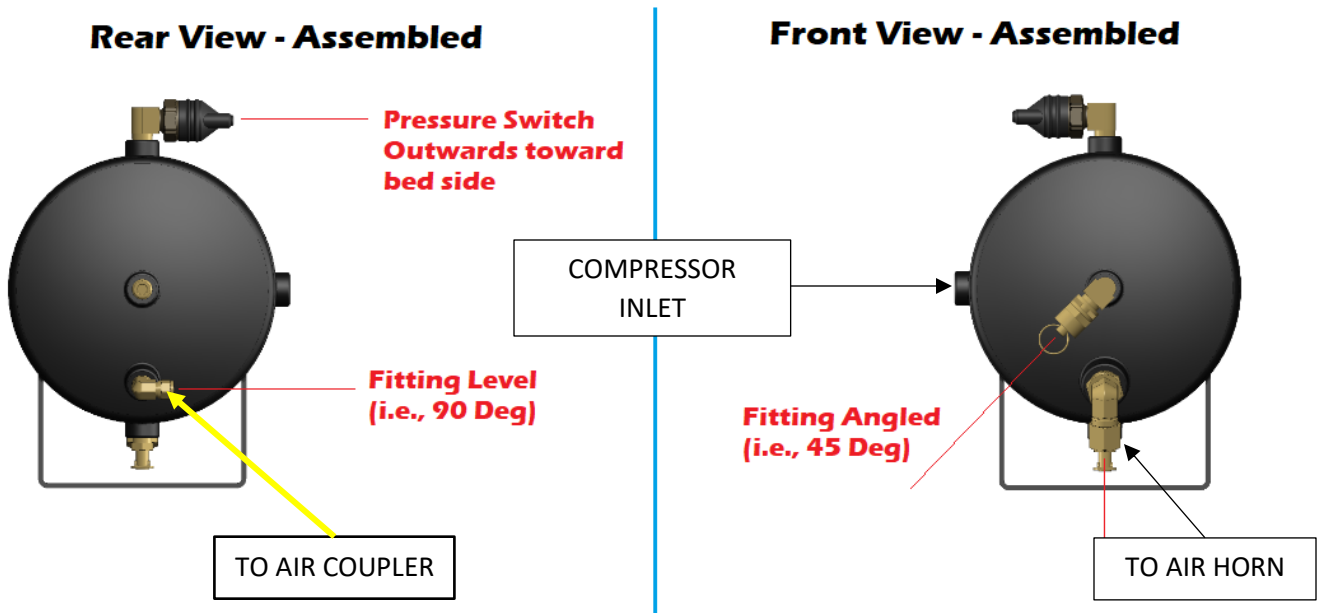

Figure 7 - Air Tank, assembled views

9.3. Assemble Air Compressor to Bracket

- 9.3.1. Remove Compressor from packaging, included hardware, and air filter.
- 9.3.2. Pry-open plastic air filter housing and install foam filter inside. If desired, attached fittings for remote air filter; otherwise assemble air filter to end of Compressor and tighten snugly.



- 9.3.3. Open included hardware bag and install Air Compressor to HD18-101 Bracket, as shown below. Recommended to apply Medium-Strength Loctite (i.e., Blue) to threads before installing, then Torque to 20 in-lbs

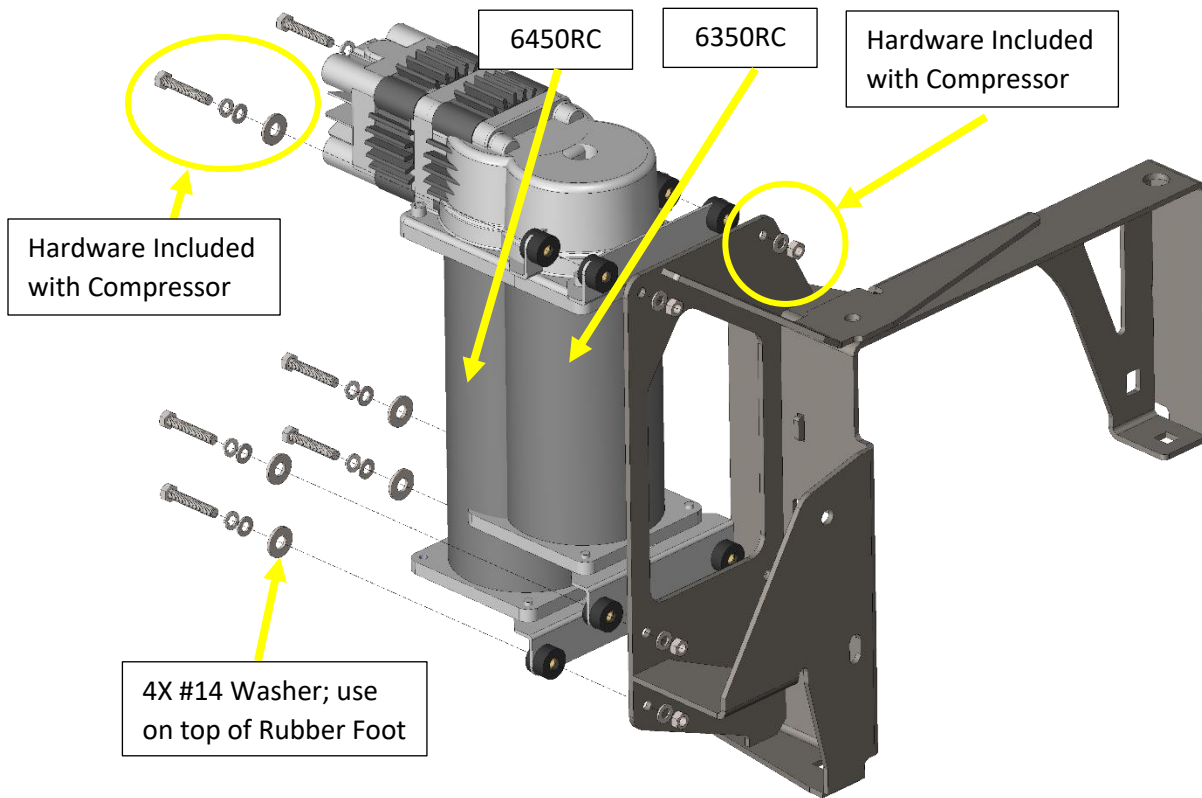

Figure 8 - Air Compressor with HD18-101 Bracket, exploded view

9.3.4. Loosely install #6 bolt, #9 & #10 washers, and #13 nut to Bracket in two (2) holes, shown below. Ensure nuts are loose, so that bolts have at least 3/16" of play; HD18-202 must be able to slide into place.

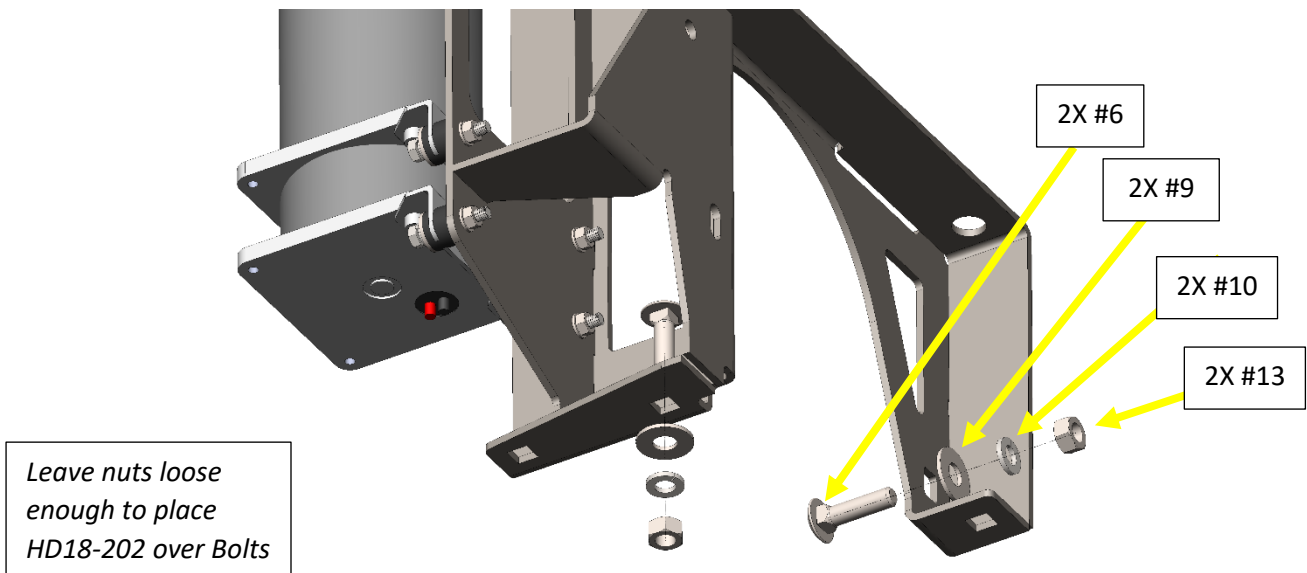

Figure 9 - HD18-101 Bracket with HD18-202 attachment bolts, exploded view



GMHD-230/734/OBA Installation and Operation Manual

10. On-Vehicle Mechanical Assembly Steps

Complete following steps *on vehicle*.

Raise vehicle off ground using appropriate vehicle lift, ramps, or jack stands, to improve ease of installation.

DANGER: Follow all safety precautions for raising vehicle and working beneath it; consult vehicle owner's manual.

Note: Any parts permanently removed from vehicle should not be discarded; store for future use if Kit is removed. It highly recommended to pre-soak ALL OE vehicle fasteners with WD-40, PB-Blaster, etc. before attempting to loosen fasteners! This is especially critical on blind, threaded holes, where nuts/threads are not easily replaced.

10.1. Prepare Mounting of Air Tank, and Air Compressor Brackets

10.1.1. Remove passenger side, 1st (front most), and 2nd Bed-to-Frame attachment bolts, as shown below.

This hardware will be reused, and special care should be taken to loosen and remove these bolts.

Caution: Many sources recommend Bed-to-Frame bolts NOT be loosened using impact/air drivers, as it may cause blind nut to break loose inside of bed support rail. Use care when loosening these bolts and consider first heating bolts to minimum 300 deg F to soften any OE thread-locker.

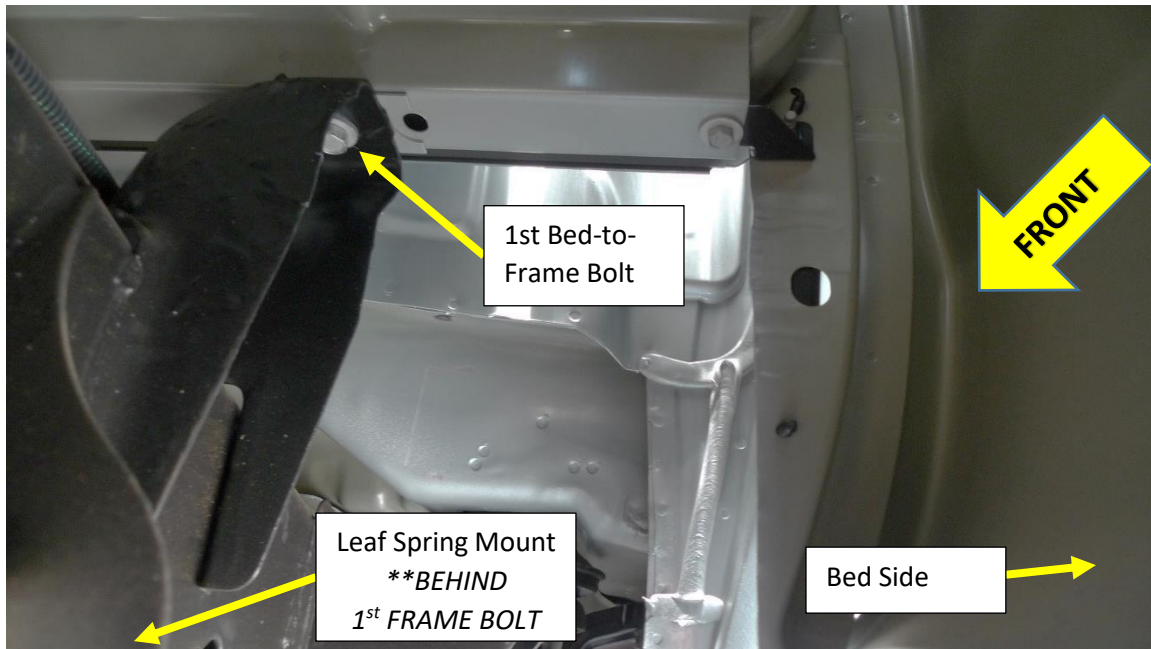

Figure 10 - HD18-101, Passenger Side, 1st (front most) Bed-to-Frame Attachment Bolt

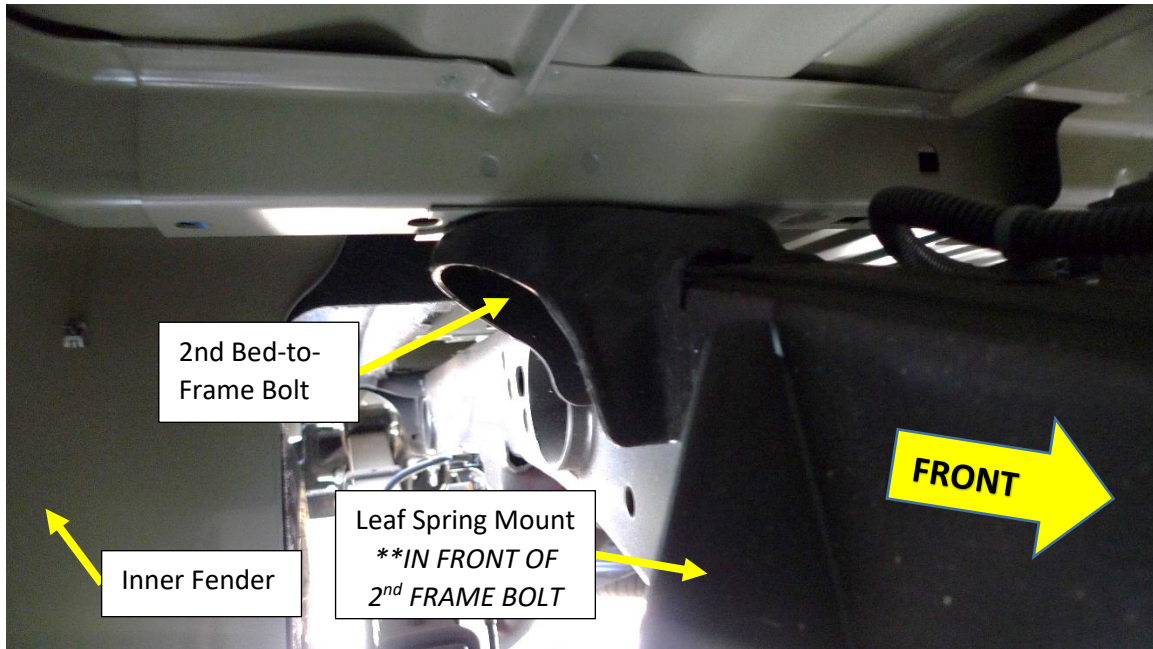

Figure 11 - HD18-201, Passenger Side, 2nd Bed-to-Frame Attachment Bolt

10.1.2. 2011-2019 VEHICLES ONLY

Permanently remove passenger side, front most, bed-side-to-bed-floor corner brace, as shown below; the brace and its hardware will not be re-used.

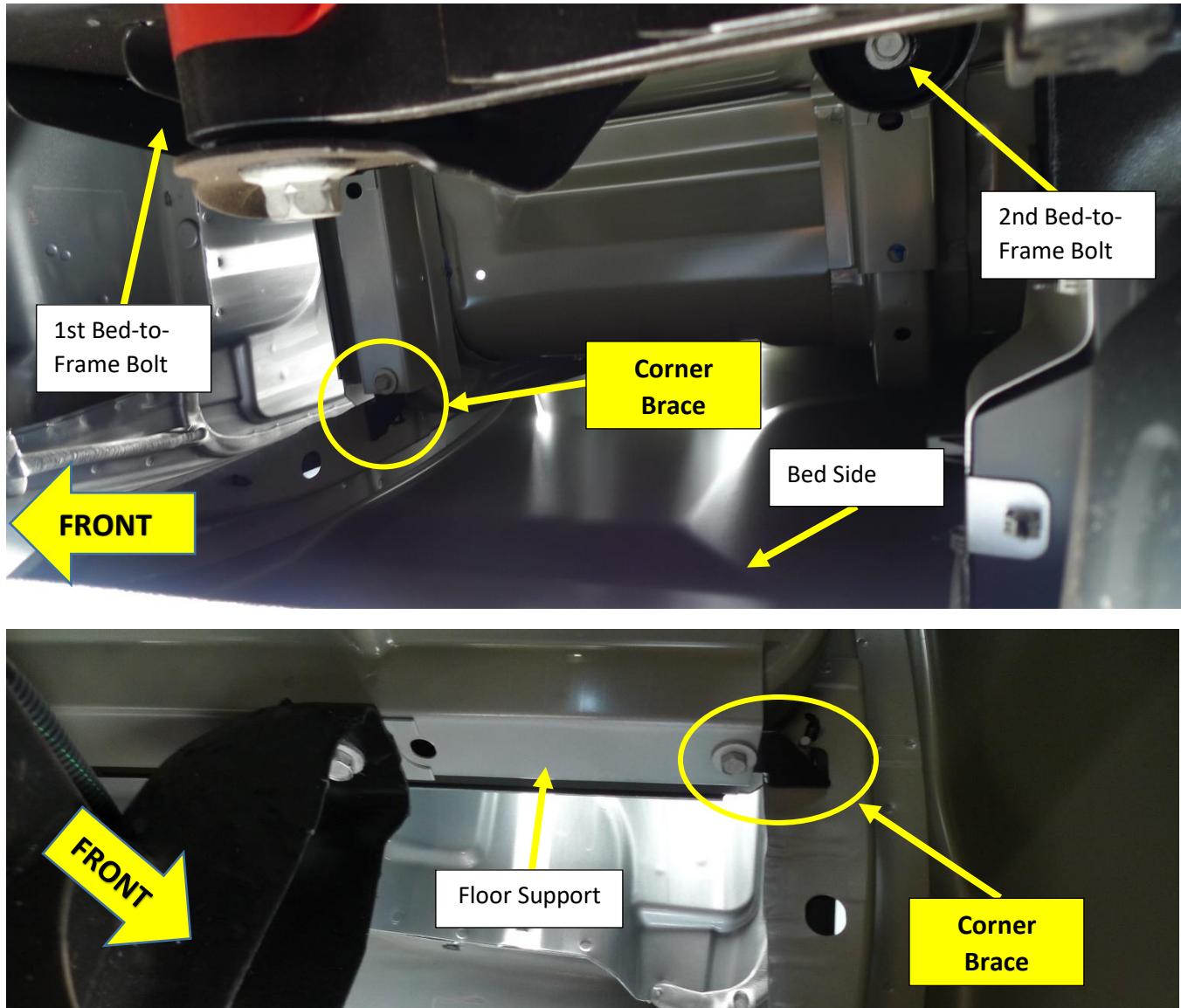
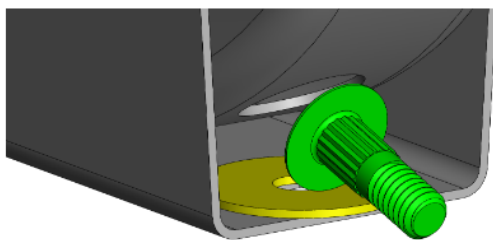

Figure 12 - (2011-2019 ONLY) Passenger Side, Bed Side Corner Brace, remove

10.1.3. Insert HD18-101 outer floor attachment bolt into floor support, using sequence shown below

1. Place #9 washer over top of bed floor support rail, outer most hole
2. Using needle nose pliers, slightly insert #7 bolt into larger oblong body hole above washer
3. With bolt slightly inserted into oblong body hole, rotate downwards, then insert through washer
4. While holding bolt in place using needle nose pliers (i.e., hold ribs on neck of bolt), slide #12 washer over threads, then stack two (2) #9 washers and tighten #13 nut until #12 washer begins to seat itself on ribbed neck. This step is complete when #12 washer is seated far enough to see some ribs below washer, and washer won't fall off. Remove, but retain both washers and nut for further use.



1. Washer over hole

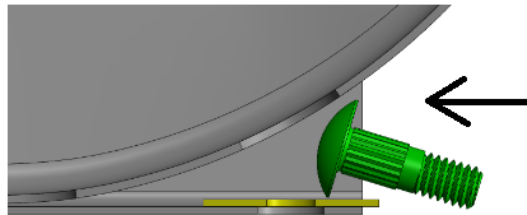

2. Bolt insertion flat

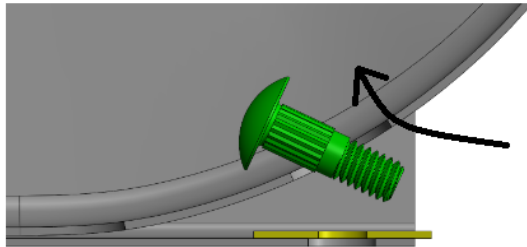

3. Bolt into oblong hole

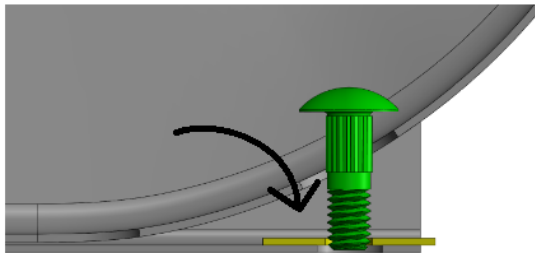

4. Bolt rotated down through washer

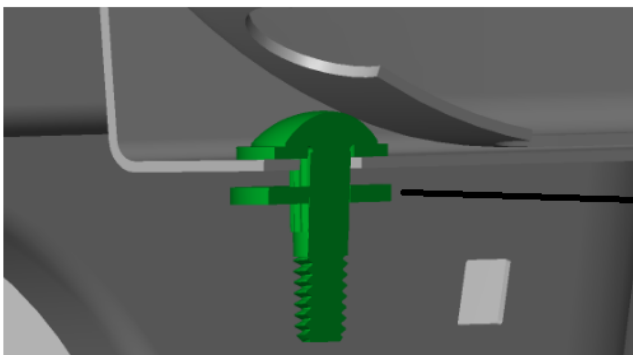

5. Bolt in final position with 2nd washer pressed on below floor support

Figure 13 - HD18-101 Outer Floor Attachment Bolt, install sequence and section view



GMHD-230/734/OBA Installation and Operation Manual

10.1.4. 2011-2019 VEHICLES ONLY

Insert HD18-201 outer floor attachment bolt into floor brace, using sequence shown below

NOTE: On some vehicles (i.e., Dual Rear Wheel), there may exist a blind nut inside of bed floor support rail; if your vehicle has a threaded hole, discard this step. **find an M8 X 1.5 X 25mm Hex Bolt taken from Horn disassembly and use that bolt along with #12 washer between Bracket and Bed.**

1. Locate hidden slot found on 2nd bed floor support rail; slot is hidden by bed side.

2011-2019 2500HD/3500HD

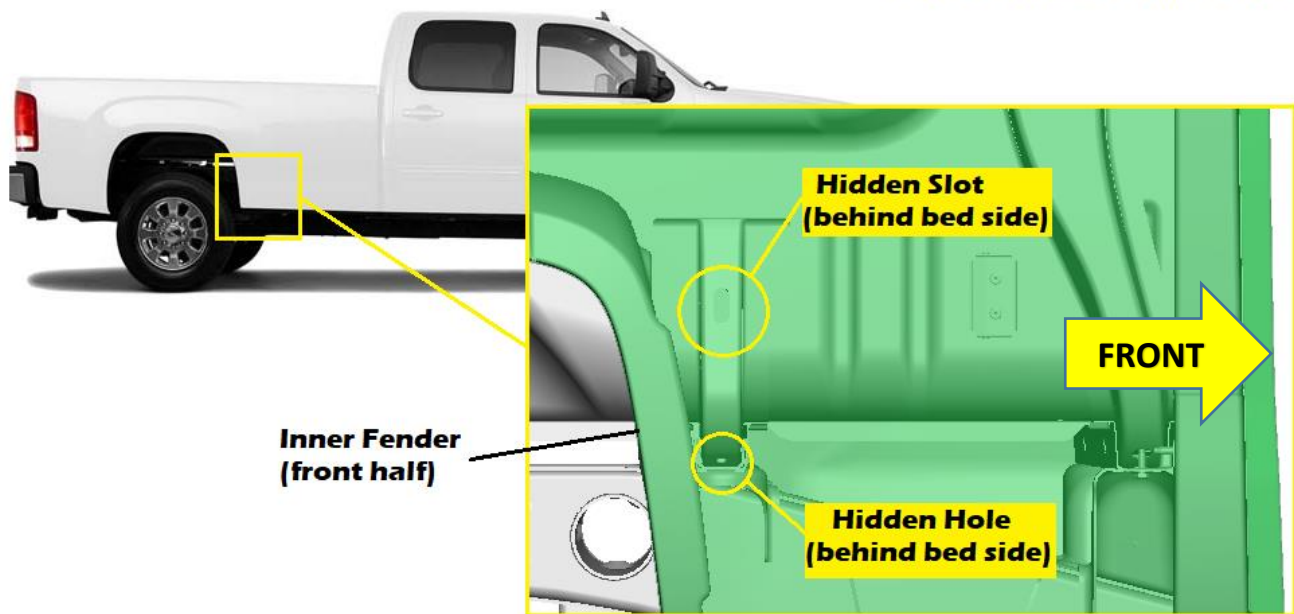

Figure 14 - (2011-2019 ONLY) HD18-201 Outer Attachment Bolt, location

2. Take #15 long plastic zip tie and firmly tie a knot to its end using included long section of fish line.

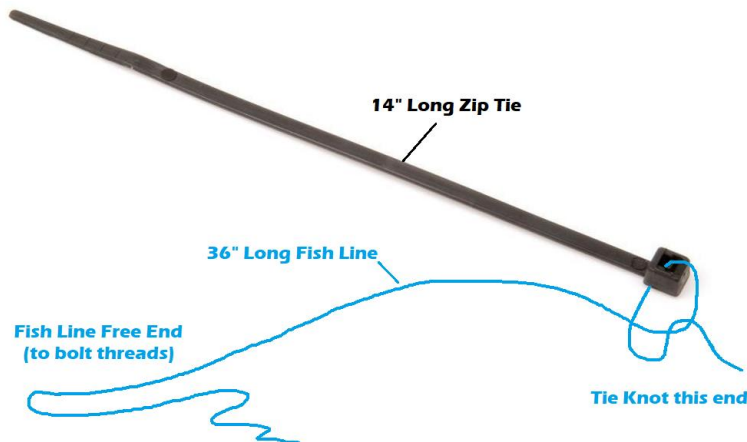

Figure 15 - (2011-2019 ONLY) Zip Tie with Fish Line

GMHD-230/734/OBA

Installation and Operation Manual

3. Insert zip tie through hidden slot (i.e., downwards) until its tapered end protrudes through bottom hole; ensure fish line is secure with enough length to handle and easily work with.
4. Place #9 washer over fish line and zip tie, then drop into slot until it comes to rest inside, above hole; use pick, or magnet to make sure washer is flat, as shown below.
5. Grasp free long end of fish line and tie a SECURE DOUBLE KNOT around end of #7 bolt threads. Pull zip tie entirely through bottom hole, and grasp fish line, as shown below.
6. Hold #7 bolt by its threads and drop into hidden slot, large flange end FIRST (i.e., insert only half of flange and rotate/pivot bolt until it freely drops in), as shown below. DO NOT ALLOW FISH LINE TO COME OFF
7. Gently pull fish line out of bottom hole; use a pick, or magnetic retrieval tool to manipulate bolt, until its threads can be pulled through washer and hole, as shown below.

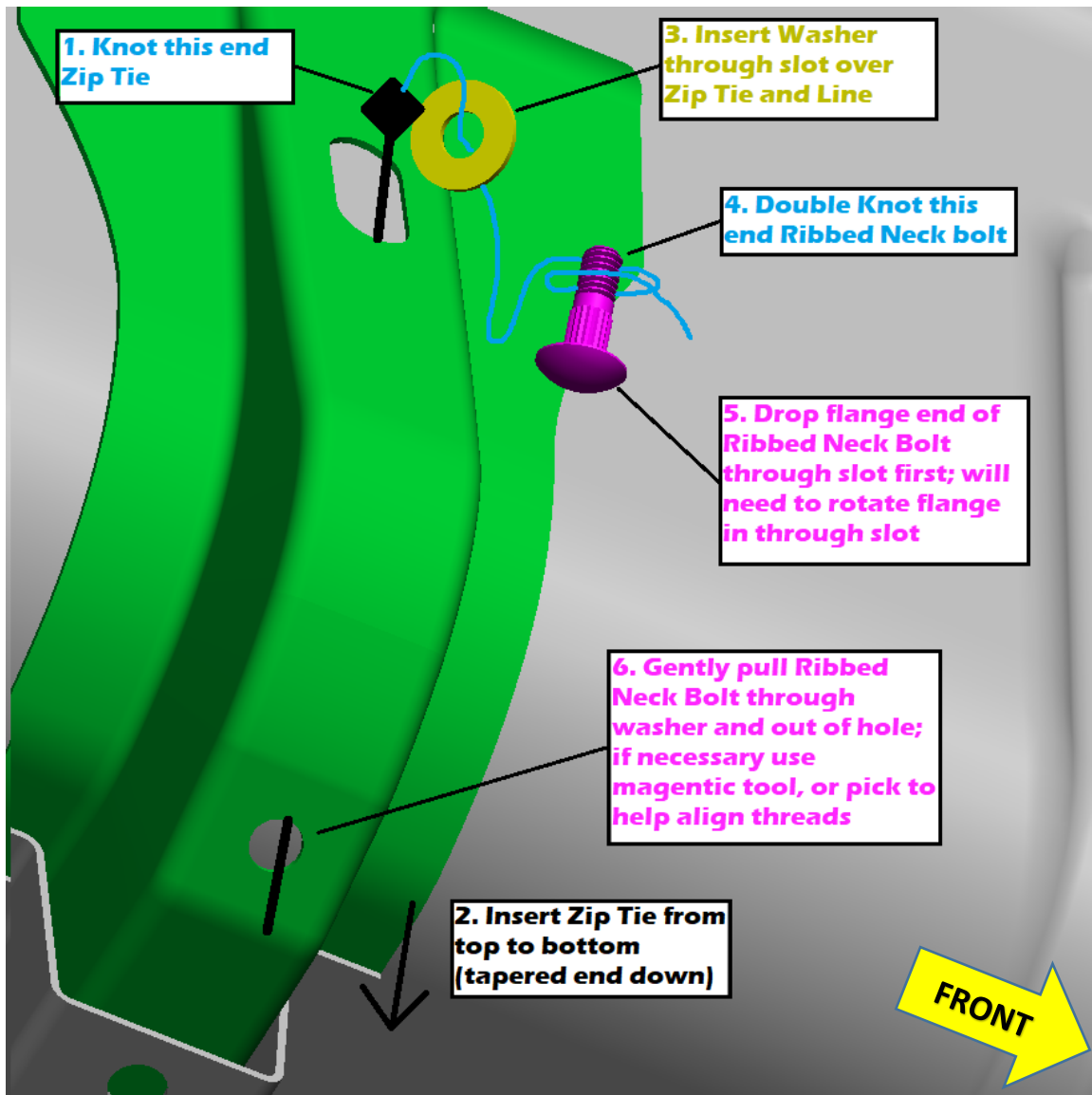

Figure 16 - (2011-2019 ONLY) HD18-201 Outer Attachment Bolt, insertion sequence



GMHD-230/734/OBA

Installation and Operation Manual

8. With bolt in hole, cut fish line and discard. Keep zip tie and use to secure tubing/wiring later on.
9. While holding bolt in place using needle nose pliers (i.e., hold ribs on neck of bolt), slide #12 washer over threads, then stack two (2) #9 washers and tighten #13 nut until #12 washer begins to seat itself on ribbed neck. This step is complete when #12 washer is seated far enough to see some ribs below washer, and washer won't fall off. Remove, but retain both washers and nut for further use.

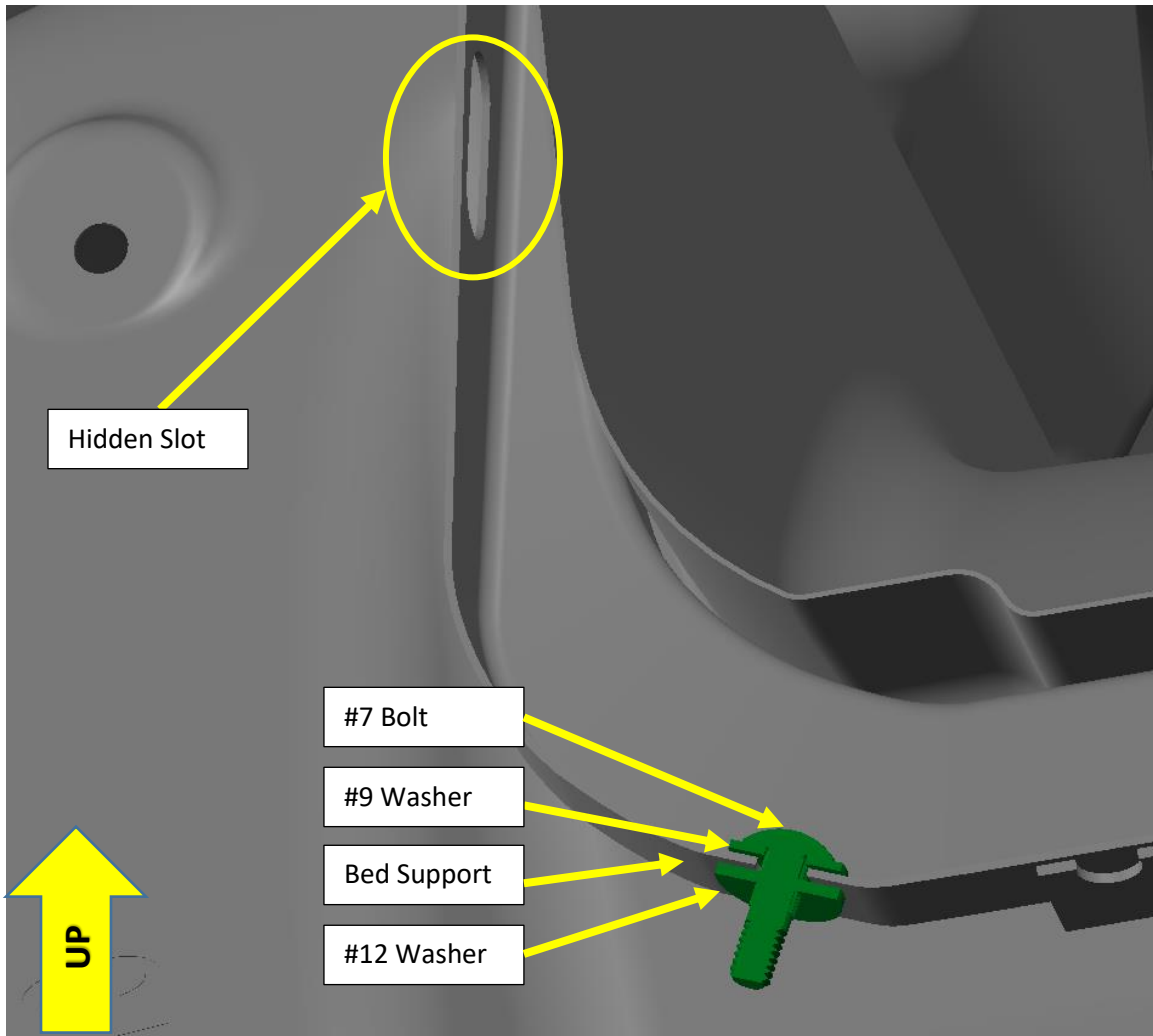

Figure 17 - (2011-2019 ONLY) HD18-201 Outer Attachment Bolt, final position section view

10.2. Mount HD18-101 Air Compressor Assembly to Frame & Body

10.2.1. Grasp HD18-101 Air Compressor Bracket Assembly, then while inserting upwards between bedside and frame, rotate it into position until mounting holes align, as shown below.

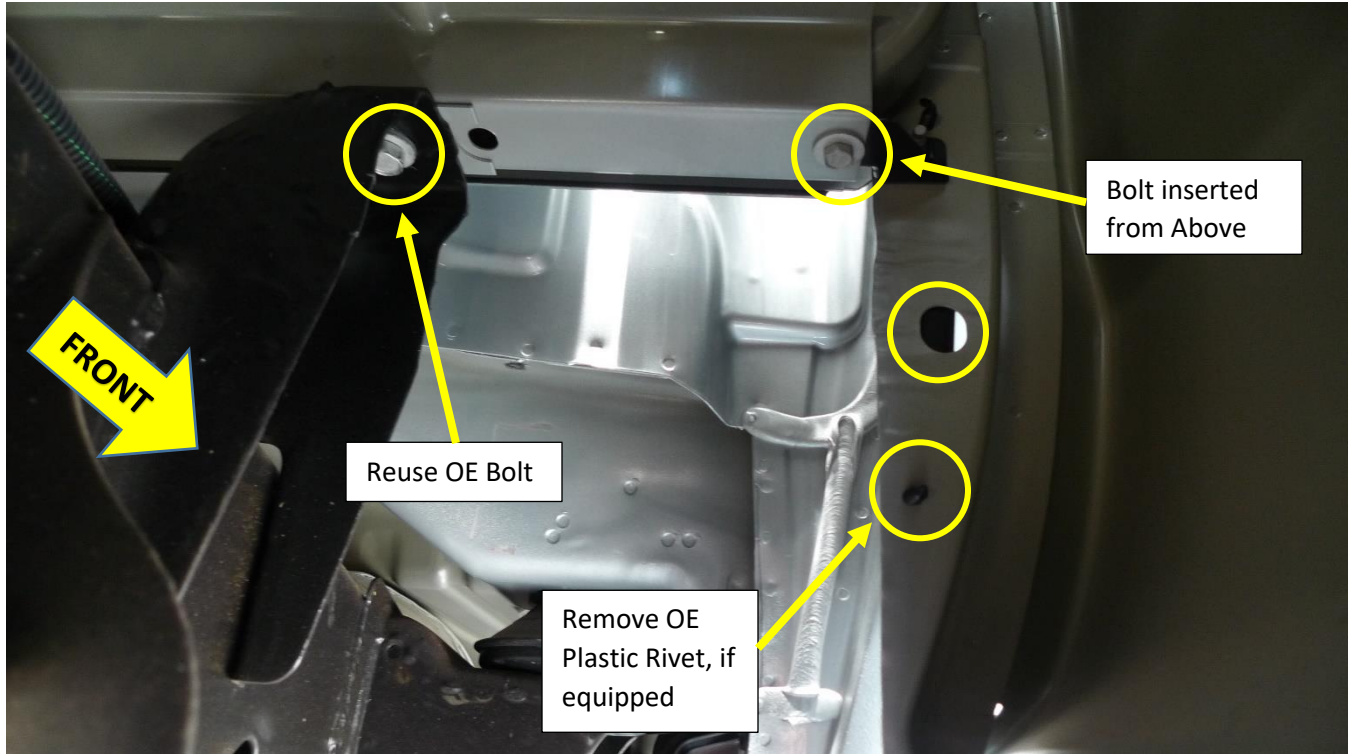

Figure 18 - Air Compressor Bracket Assembly, attachment points

10.2.2. While holding Bracket Assembly, loosely install OE bed-to-frame attachment bolt (apply medium-strength thread locker to threads), plus loosely install remaining hardware #2, 3, 4, 5, 8, 9, 10, 11, 13, as shown below. ([click to return to hardware list](#))

10.2.3. Once all hardware is in place, final tighten bolts using following sequence.

1. Tighten OE Bed-to-Frame bolt to 45-52 lb-ft ****verify with your dealer for your specific year**
2. Tighten Outer Floor Attachment Bolt to 75 lb-in
3. Tighten front upper bedside bolt to 75 lb-in
4. Tighten front lower bedside bolt to 37 lb-in



GMHD-230/734/OBA

Installation and Operation Manual

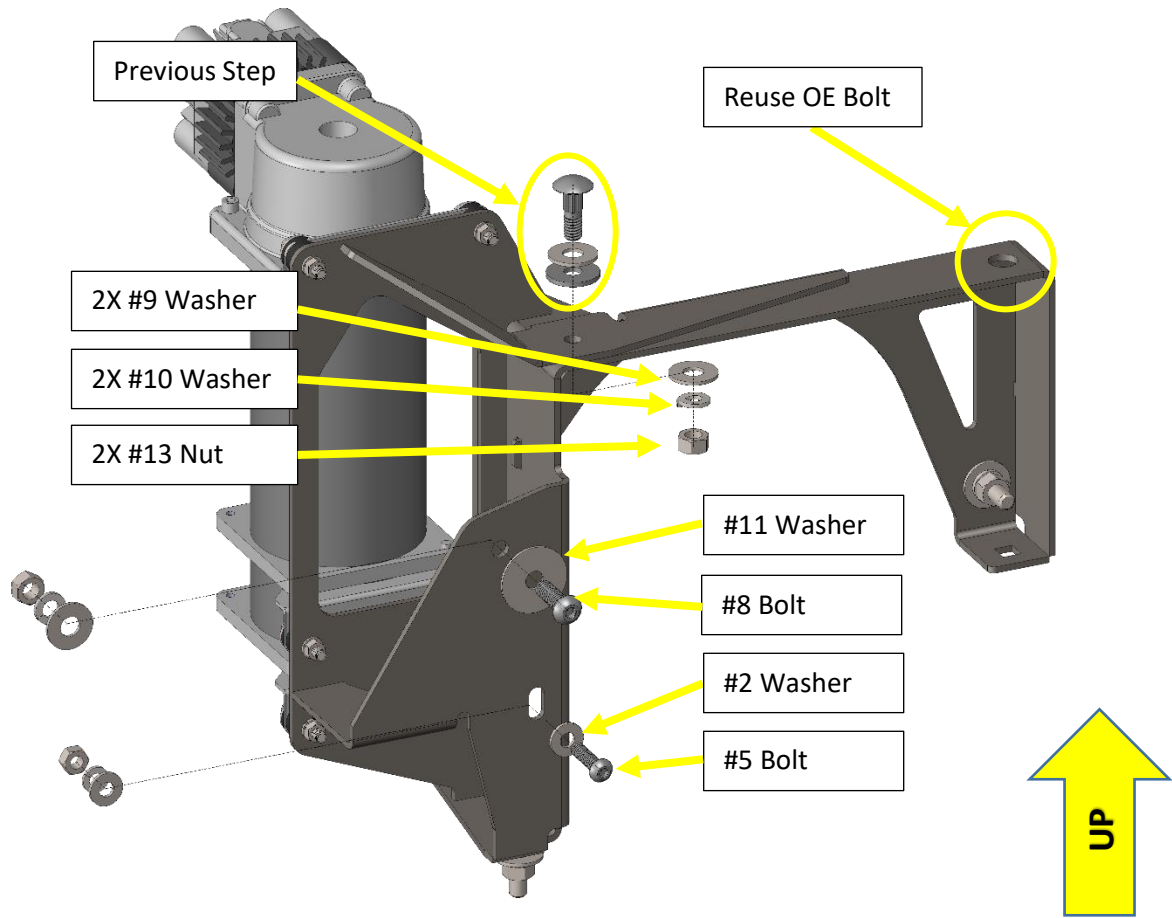

Figure 19 - Air Compressor Bracket Assembly, exploded view



Figure 20 - Air Compressor Bracket Assembly, installed

10.3. Mount HD18-201, Air Tank, Rear Half Bracket

10.3.1. Grasp HD18-201 Bracket Assembly, then while inserting upwards between bedside and frame, rotate it into position until mounting holes align, as shown below.

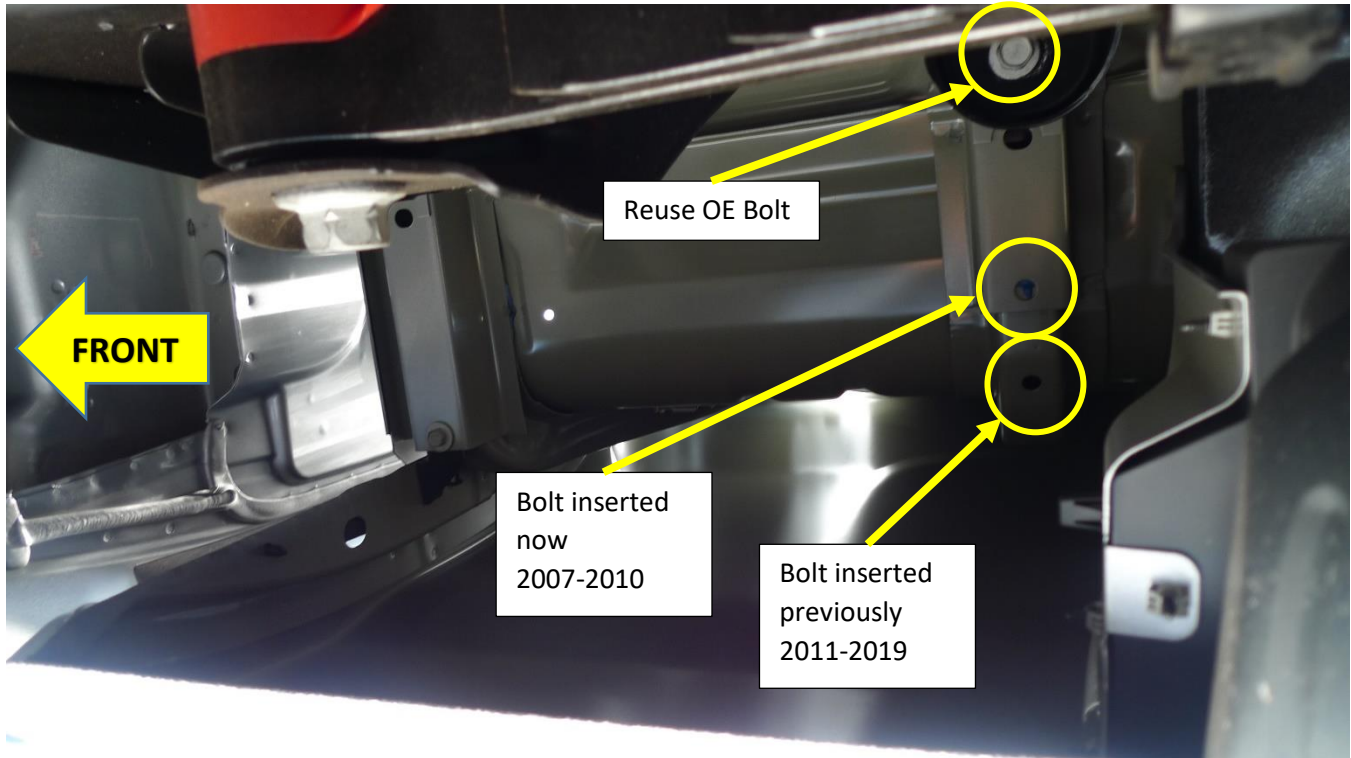

Figure 21 - HD18-201 Air Tank Bracket, attachment points

10.3.2. While holding Bracket Assembly, loosely install OE bed-to-frame attachment bolt (apply medium-strength thread locker to threads), plus loosely install remaining hardware, shown below

2007-2010 VEHICLES ONLY

- #8, 9, 12, 9, 10, 13 (bottom to top order)
- NOTE: #12 washer is inserted between Bracket and Floor Support Rail (i.e., Body)

2010-2019 VEHICLES ONLY

- #13, 10, 9 (bottom to top order) - #12, 9, 8 (installed previously)

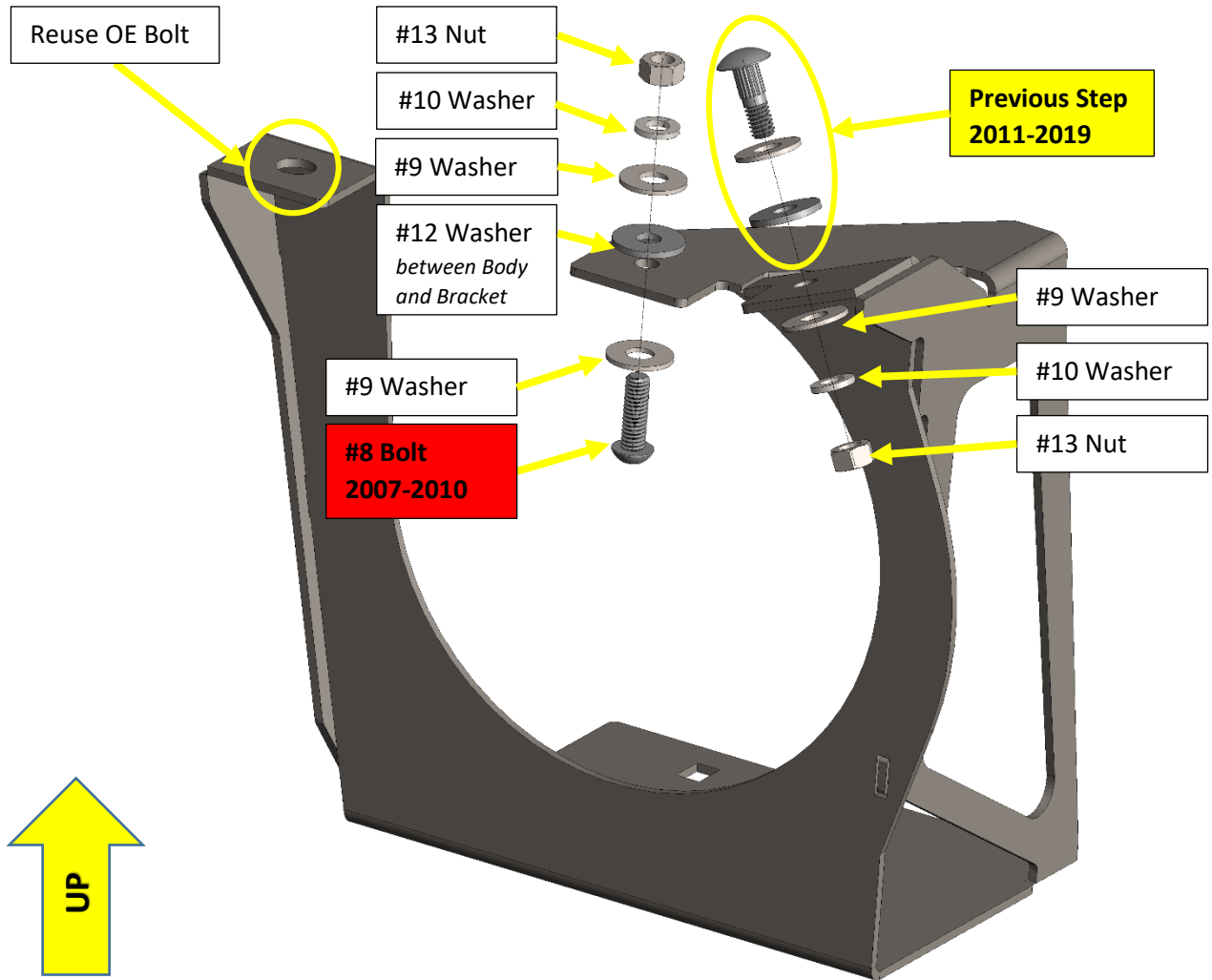

Figure 22 - HD18-201 Air Tank Bracket, exploded view

10.3.3. Once all hardware is in place, final tighten bolts using following sequence.

1. Tighten OE Bed-to-Frame bolt to 45-52 lb-ft **verify with your dealer for your specific year
2. Tighten 5/16"-18 Outer Floor Attachment Bolt to 75 lb-in



Figure 23 - HD18-201 Air Tank Bracket, installed

10.4. Install Air Tank, and HD18-202 Bracket

10.4.1. With Air Compressor Bracket Assembly installed on frame, lift Air Tank vertically at an angle up and over front leaf spring mount, and place rear tank foot on HD18-201 Bracket, as shown below.

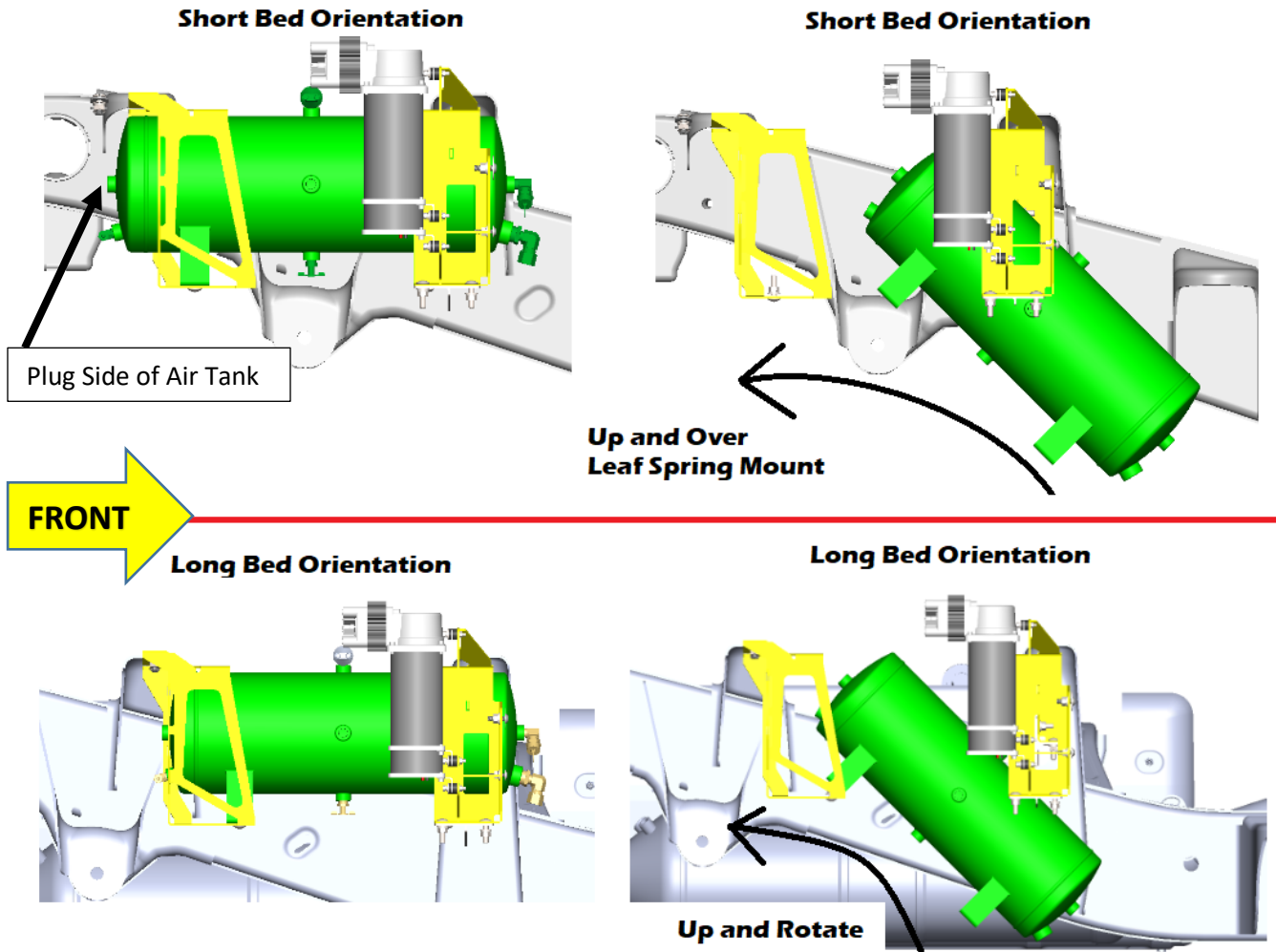

Figure 24 - Air Tank, insertion method (Short & Long Bed)

10.4.2. While holding Air Tank into position, take HD18-202 Air Tank Bracket, and slide it into position over HD18-101 bolts (installed during bench assembly), until seated, as shown below.

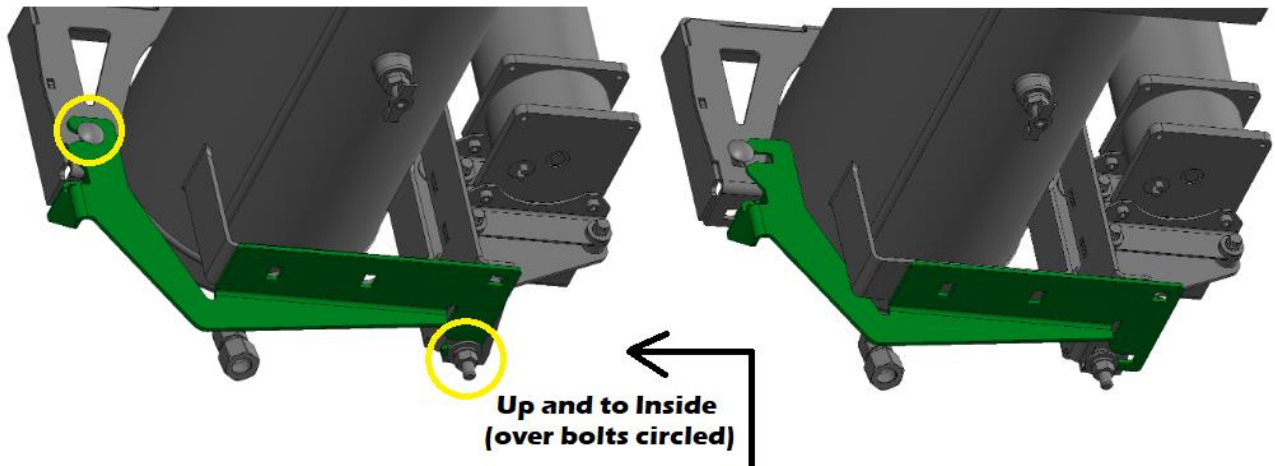

Figure 25 - HD18-202 Bracket, insertion method

10.4.3. Using hardware items #6, 9, 10, and 13, final install Air Tank onto Brackets, as shown below. Apply Medium-Strength Loctite (i.e., Blue) to fasteners, and torque to 75 lb-in

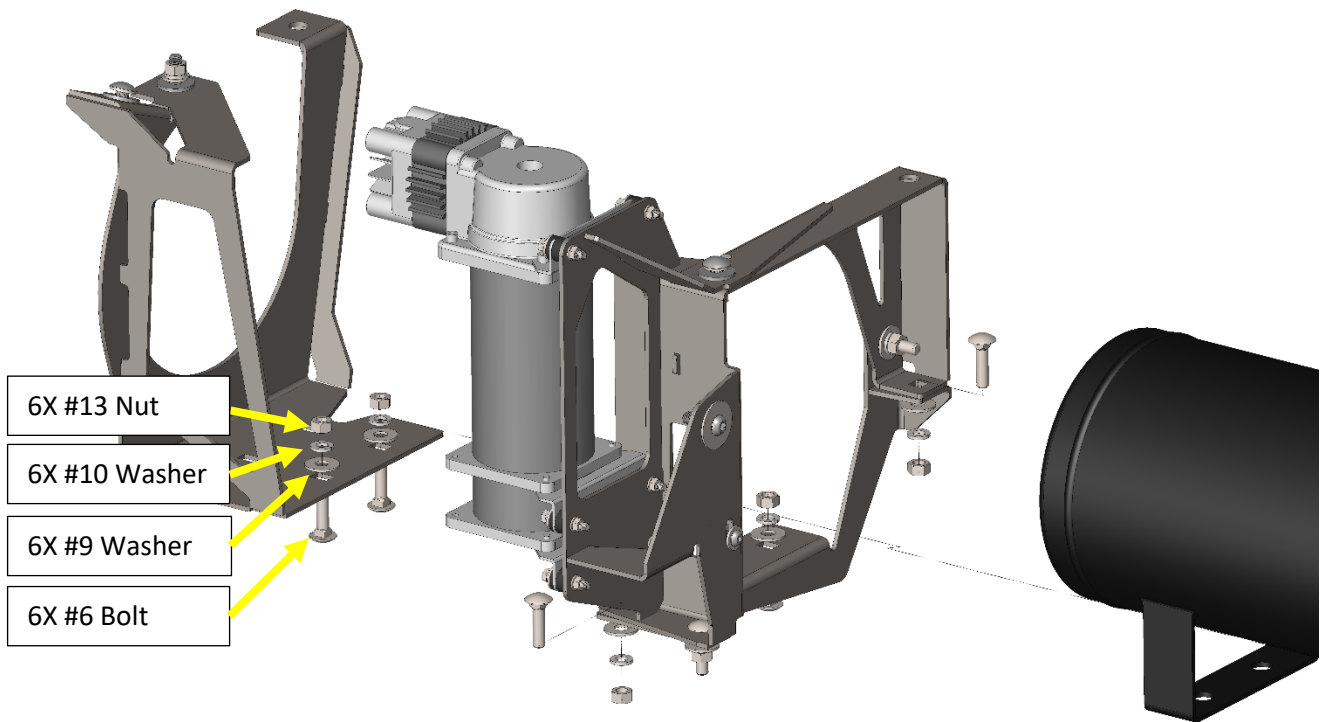

Figure 26 - Air Tank and Air Tank Brackets, exploded view

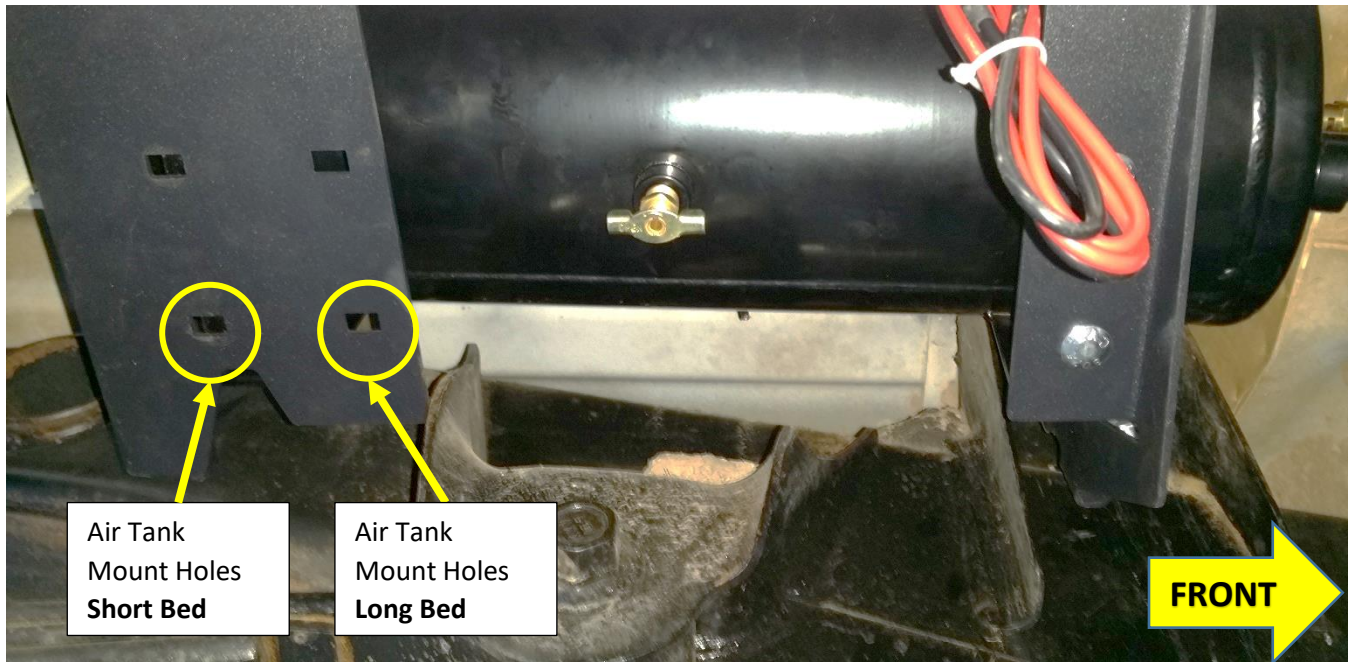

Figure 27 - Air Tank Installed, (2011+ Short Bed frame shown)

10.5. Connect Air Compressor to Air Tank and Electrical

- 10.5.1. Route Air Compressor leader hose as necessary, so that it easily threads into port listed as "[Compressor Inlet](#)" in view above. Apply Kleinn Air Horn Juice on air line threads, per instruction, and tighten firmly
- 10.5.2. Use supplied plastic zip ties to hold Air Hose to Compressor Bracket.
- 10.5.3. Connect Air Compressor wiring, to previously installed wiring and secure using supplied wire loom.

10.6. Connect Air Filter to Air Compressor

- 10.6.1. If Remote Air Filter Fitting was installed during bench assembly, mount Remote Air Filter now, and connect tubing to Compressor, using supplied items.

10.7. Connect Remote Quick Connect Kit to Vehicle

- 10.7.1. Route and attach Quick Connect Coupler Kit to vehicle, as desired using attachment bracket and self-drilling fasteners, supplied in Coupler package.
- 10.7.2. Use supplied 1/4" tubing and attach to air fitting, listed as "[To Air Coupler](#)", as shown above. Some optional locations for Coupler include under hood, below bumper (shown below), in bed rail, etc.



Figure 28 - Example of Air Coupler Mounted below Bumper

10.8. 734-KIT & 230-KIT ONLY | Prepare Mounting of Air Horn Brackets

10.8.1. Remove OE Tow Hook bolts, on both sides at front of frame, as shown below.

This hardware will be reused, and special care should be taken to loosen and remove these bolts.

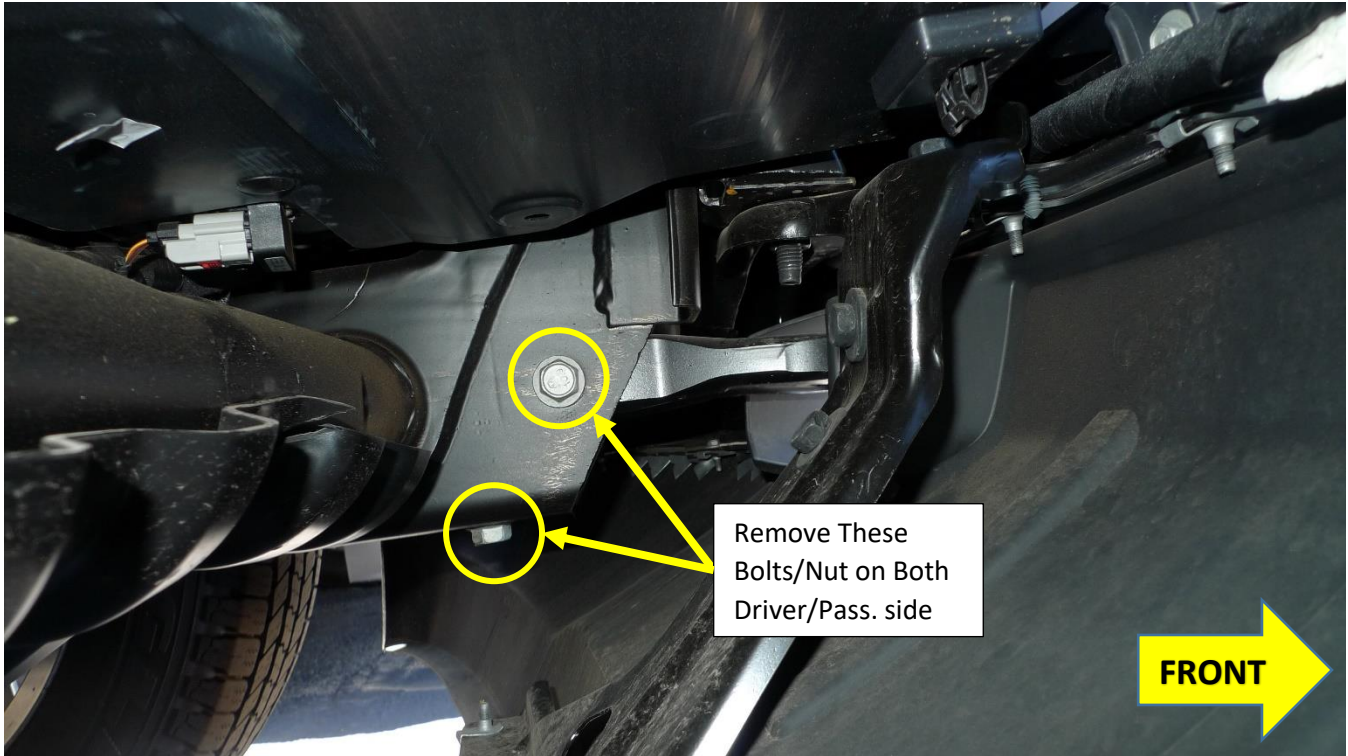

Figure 29 - OE Tow Hook Bolts, remove (2011+ Frame Shown)

10.8.2. 2007-2010 VEHICLES ONLY

Use a magnetic retrieval tool and insert #9 washer, and #7 Bolt through large hole on bottom of frame and pull through small hole, as shown below

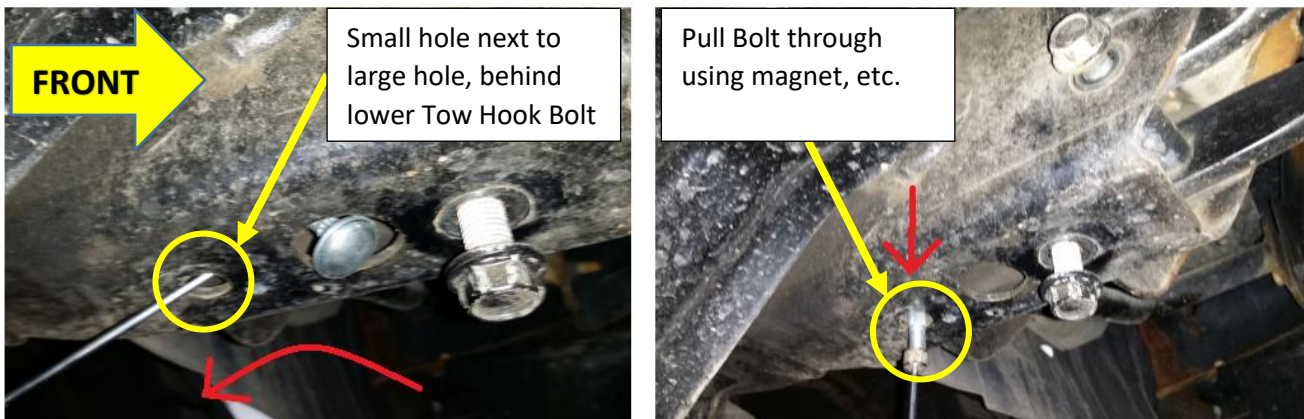

Figure 30 - (2007-2010 ONLY) HD18-301 Ribbed Neck Bolt, insertion



GMHD-230/734/OBA

Installation and Operation Manual

10.9. Mount HD18-301, Driver Side Air Horn Bracket

- 10.9.1. Clean and prepare 2X OE Tow Hook Bolts, then apply Medium-Strength Loctite (i.e., Blue) to threads.
- 10.9.2. Temporarily insert upper Tow Hook Bolt through outside of frame toward inside, so that Tow Hook remains in place; only bolt threads should be visible on inside of frame.
- 10.9.3. Before installing Bracket, take two (2) #6 Bolts, and insert them into slots, as shown below. Use tape, or similar, to temporarily hold them in place; these bolts can't be inserted with Bracket mounted

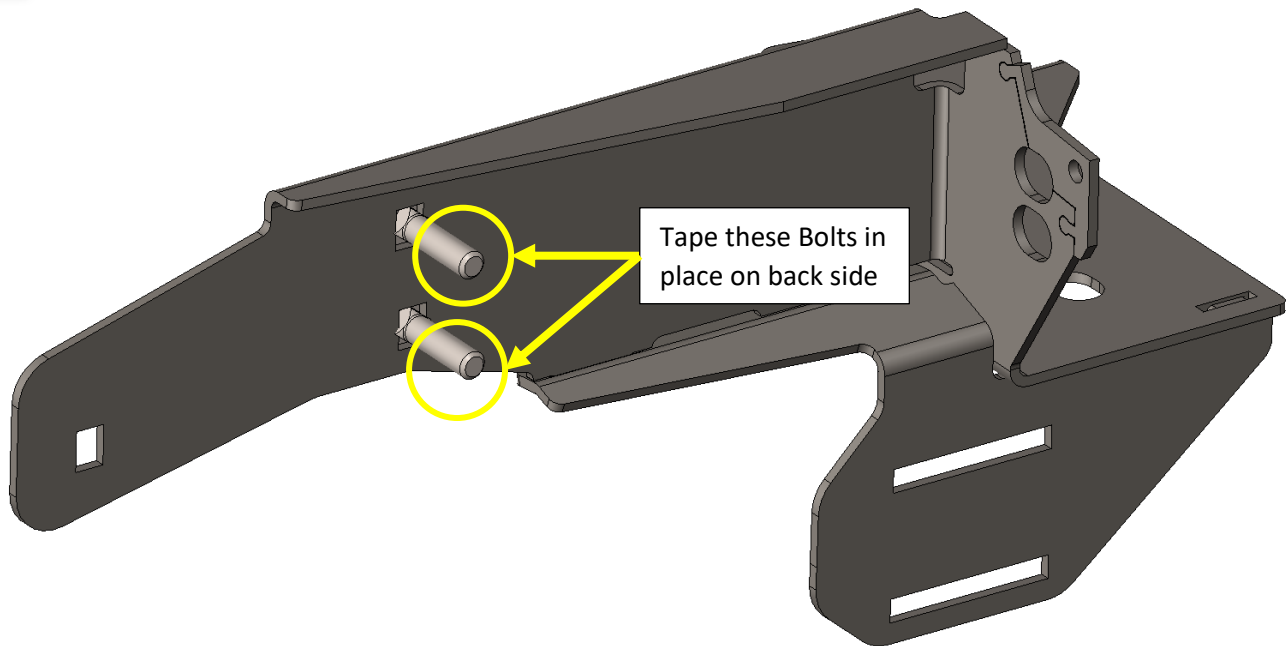

Figure 31 - HD18-301, Tape Bolts in place (ALL YEARS)

- 10.9.4. Position Driver Side Air Horn Bracket, over upper Tow Hook Bolt on inside of frame, as shown below
- 10.9.5. While holding Bracket in position, insert bottom Tow Hook Bolt through Bracket and hand tighten while holding Bracket firmly against bottom of frame, as shown below
- 10.9.6. Remove upper Tow Hook Bolt and re-insert it from inside to outside through Bracket, as shown below
 - 2011-2019: Use supplied "Puzzle Piece" and place it into position over top hole
 - 2007-2010: Discard "Puzzle Piece", as it is not used with your vehicle

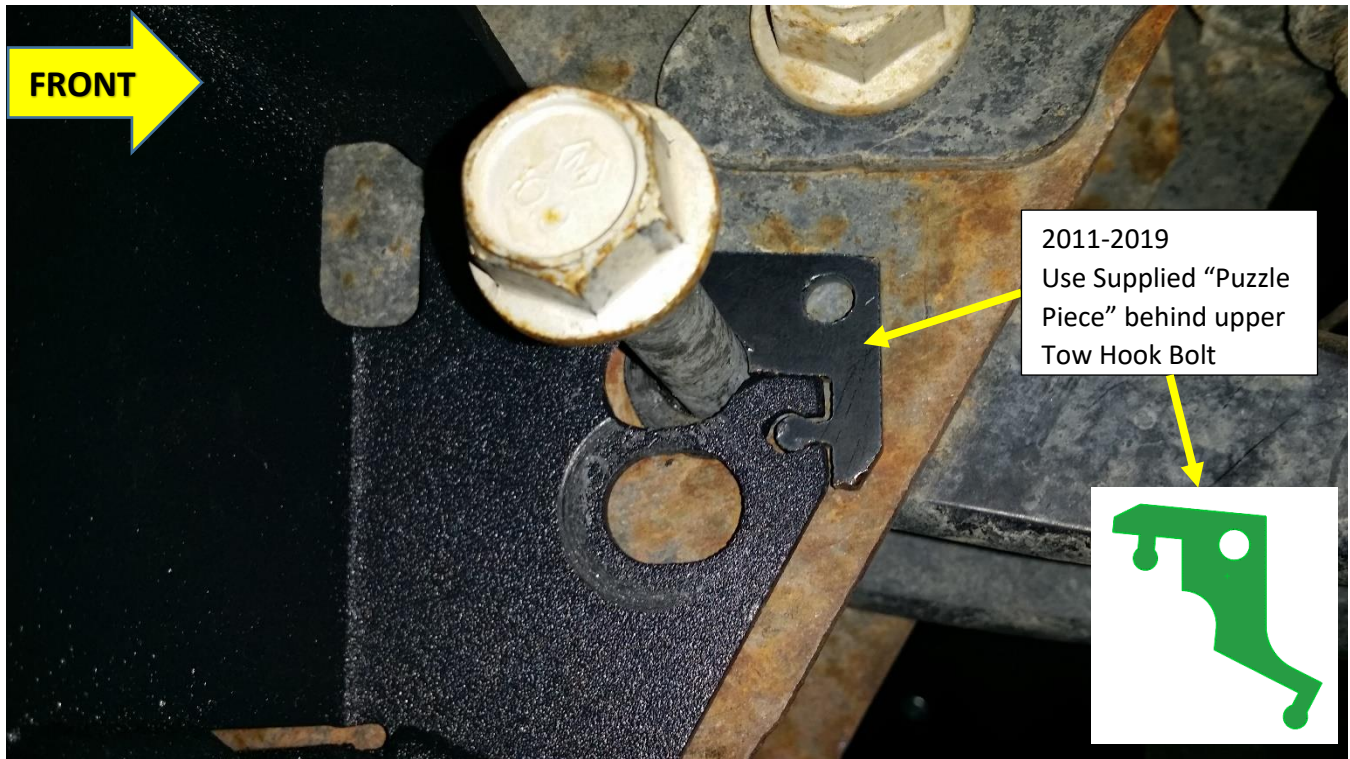

Figure 32 - (2011-2019 ONLY) HD18-301, Driver Side Bracket, installed with Puzzle Piece



Figure 33 - (2007-2010 ONLY) HD18-301, Driver Side Bracket, installed without Puzzle Piece

10.9.7. Torque OE Tow Hook Bolts to 50-60 lb-ft, starting with bottom bolt first, then upper bolt.



GMHD-230/734/OBA

Installation and Operation Manual

10.9.8. 2007-2010 VEHICLES ONLY

- Use #10 washer, and #13 nut to secure #7 Ribbed Neck Carriage Bolt; torque to 75 lb-in.

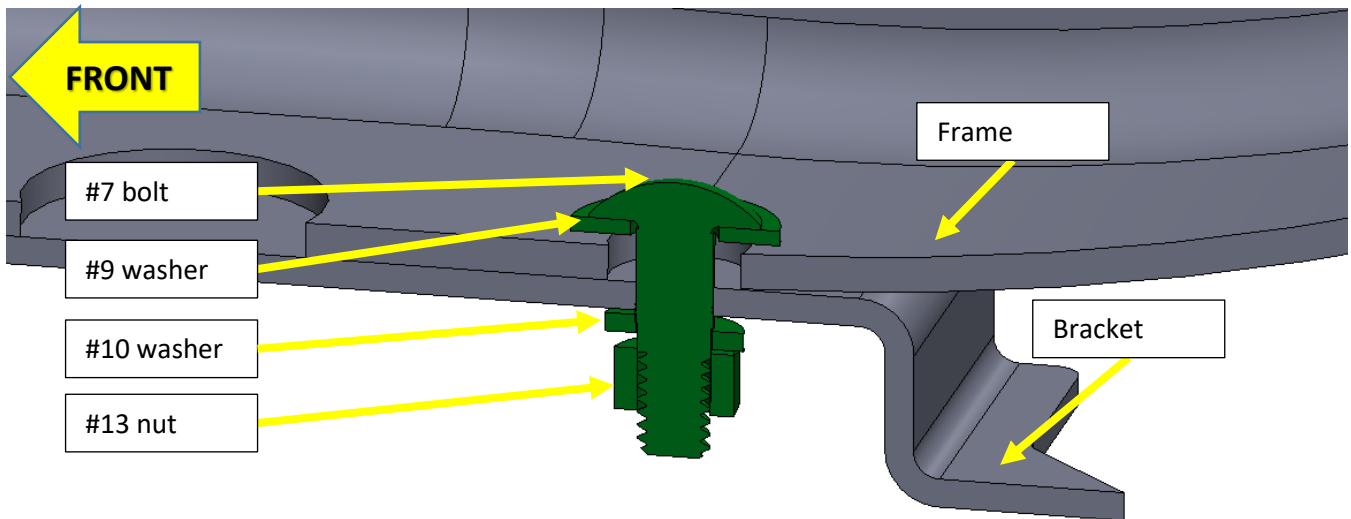

Figure 34 - (2007-2010 ONLY) HD18-301, Driver Side Bracket, Ribbed Neck Bolt, installed section view

10.10. Mount HD18-302, Passenger Side Air Horn Bracket

10.10.1. Repeat steps above to install bracket, as shown below.

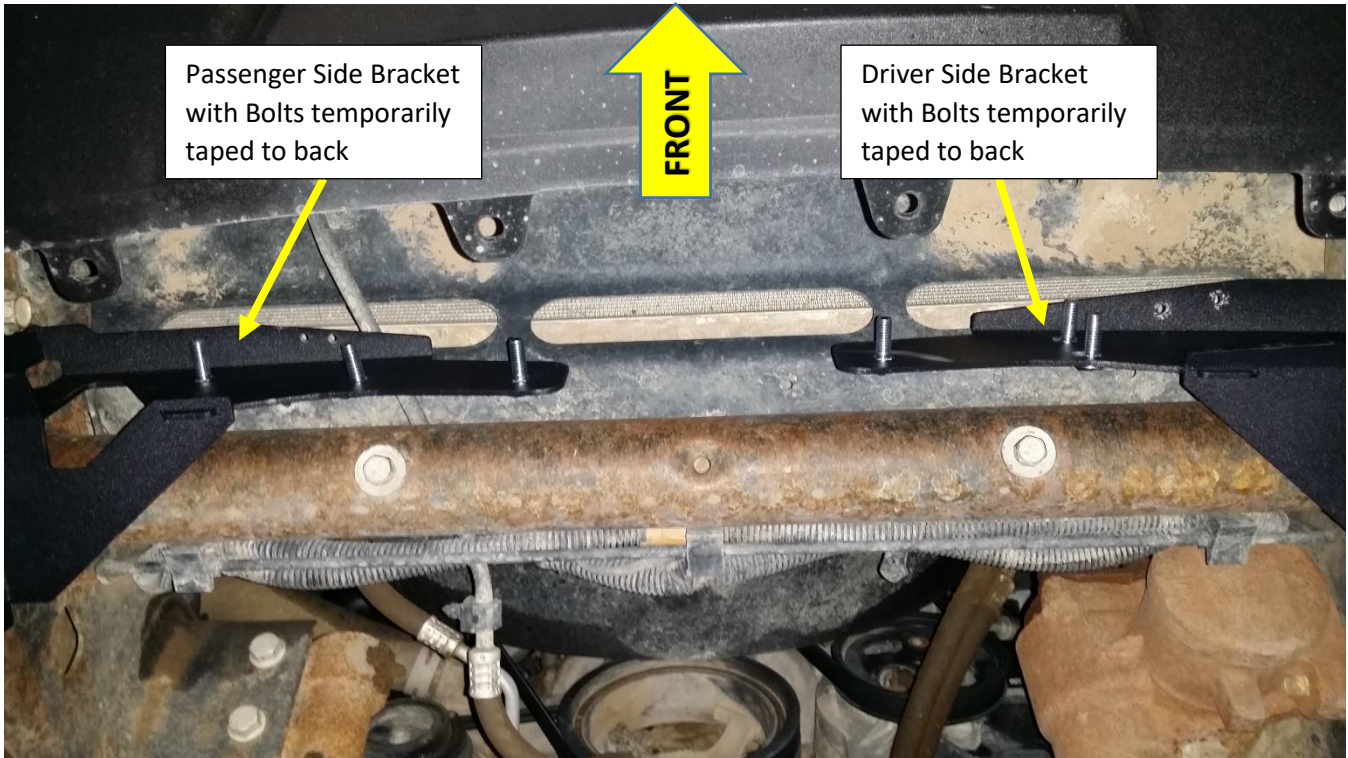

Figure 35 - HD18-302, Passenger and HD18-301, Driver Side Brackets, installed (Shown from below)

10.11. Mount HD18-303, Connector Bracket

10.11.1. 2011-2019 VEHICLES ONLY

- Do not install hardware on two (2) Driver Side #6 bolts (taped in place above). These bolts will be used to secure Small Air Horn, at later time.

10.11.2. 2015-2019 SILVERADO ONLY

- Before installing Connector Bracket, place separate small trumpet (i.e., disassembled plastic/metal shortest trumpet) on inside of bumper valance; it is not possible to insert trumpet with Bracket in place. See below figure.

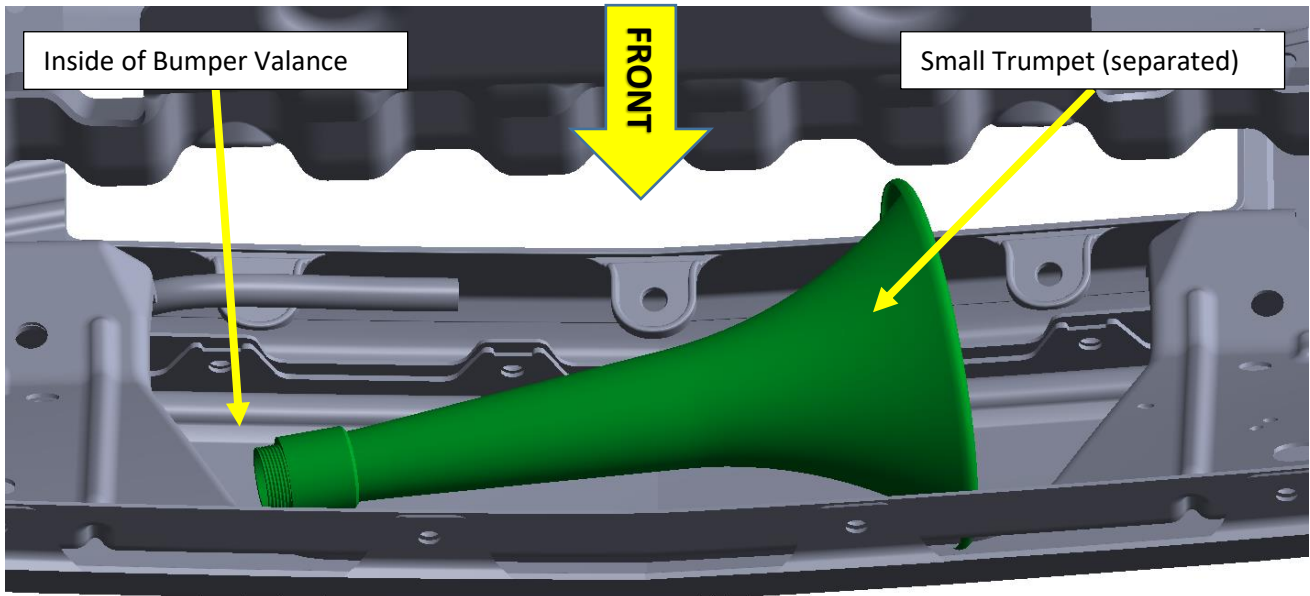

Figure 36 - (2015-2019 SILVERADOS) Small Trumpet sitting on Bumper Valance (Shown from below)

- 10.11.3. Place Connector Bracket carefully over each set of bolts temporarily taped during previous steps.
- 10.11.4. Use #9 washer, #10 washer, and #13 nut, as shown below. Before tightening nuts, position Bracket as close to center as possible, and vertically as high as possible, then final torque nuts to 75 lb-in.



Figure 37 - HD18-303 Connector Bracket, installed (Shown from below)



GMHD-230/734/OBA Installation and Operation Manual

10.12. Install Air Horns

10.12.1. 2011-2019 VEHICLES ONLY

1. With Trumpets removed from Air Horn Drivers, place Drivers onto Connector Bracket, and hand tighten a total of six (6) #6 bolt, #9 washer, #10 washer, and #13 nut, as shown below
2. Once each Driver is installed onto Connector Bracket, connect and route air tubing to each Horn, as desired. Lastly, connect Air Horn Solenoid to electric wiring routed earlier
3. Re-assemble Air Horns by threading Small, Medium, and Large Trumpets into Drivers and tighten firmly.
 - **734-KIT ONLY**, place included Trumpet Support over Medium and Large Trumpets before threading into Driver, as shown below. Do NOT use included thick rubber bushing.



4. With Air Horns installed, position each Air Horn as necessary so there is a minimum 1/4" clearance between vehicle and other horns, then torque Air Horn mounting bolts to 75 lb-in

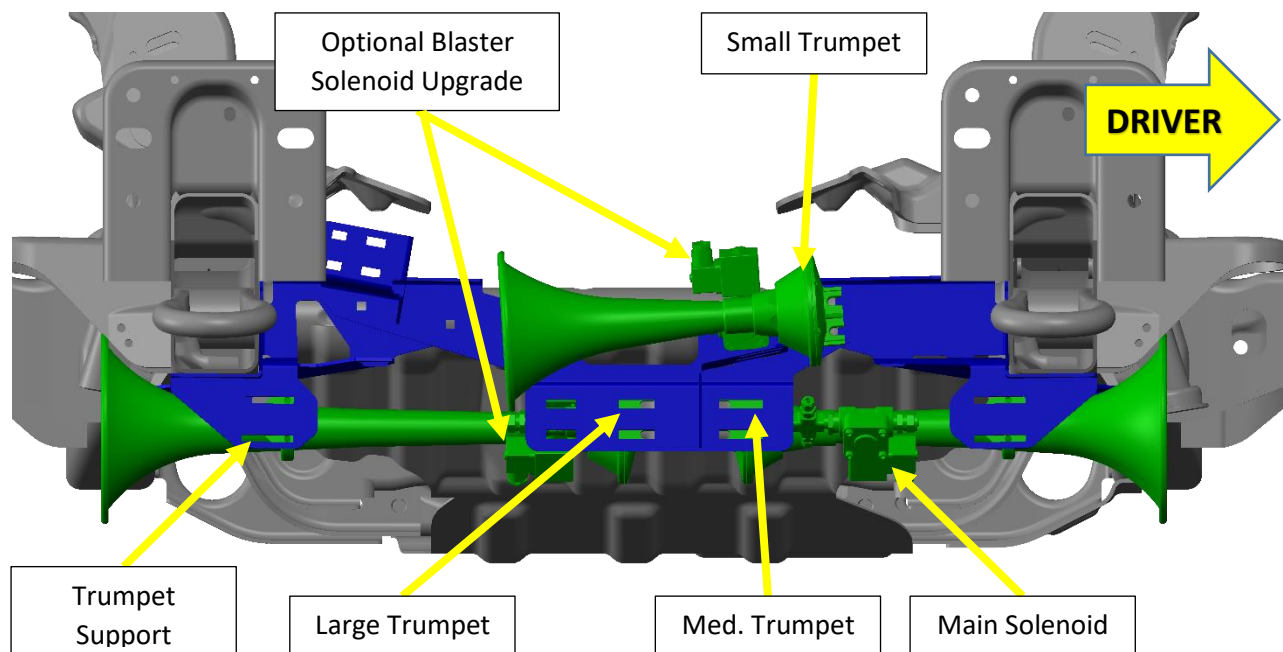

Figure 38 - (2011-2019 ONLY) Air Horn Orientation, 734-KIT, installed (Shown from Front w/o bumper)



GMHD-230/734/OBA Installation and Operation Manual

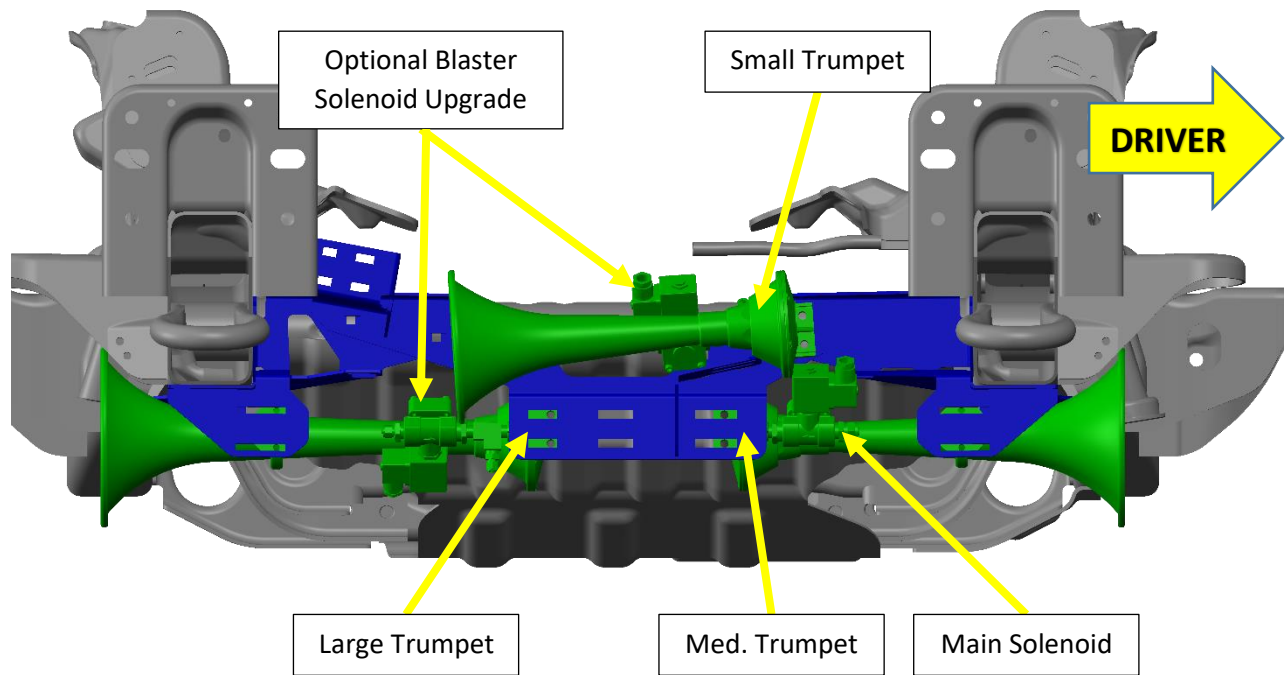

Figure 39 - (2011-2019 ONLY) Air Horn Orientation, 230-KIT, installed (Shown from Front w/o bumper)

10.12.2. 2007-2010 VEHICLES ONLY

1. Re-assemble Air Horns by threading Small, Medium, and Large Trumpets into Drivers and tighten firmly; horns will be installed complete.
2. Install Large Air Horn onto Connector Bracket first, then Medium Air Horn, then Small Air Horn; hand tighten a total of six (6) #6 bolt, #9 washer, #10 washer, and #13 nut, as shown below
3. Once each Horn is installed onto Connector Bracket, connect and route air tubing to each Horn, as desired. Lastly, connect Air Horn Solenoid to electric wiring routed earlier
4. With Air Horns installed, position each Air Horn as necessary so there is a minimum 1/4" clearance between vehicle and other horns, then torque Air Horn mounting bolts to 75 lb-in



GMHD-230/734/OBA Installation and Operation Manual

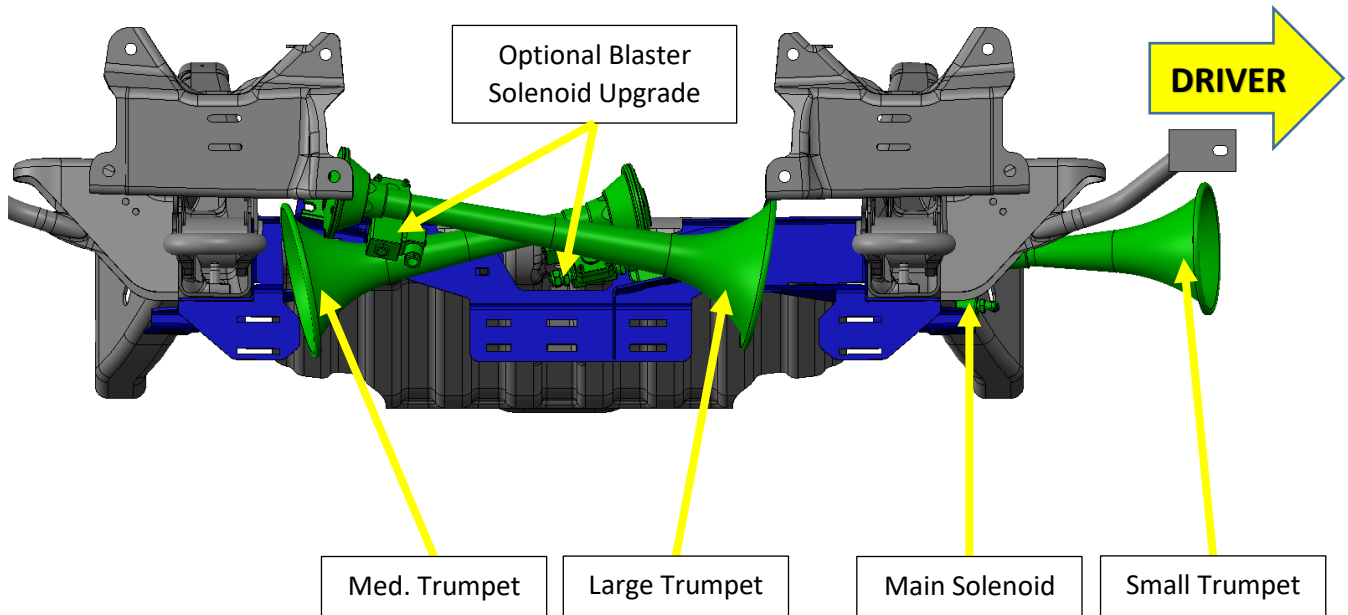

Figure 40 - (2007-2010 ONLY) Air Horn Orientation, 734-KIT, installed (Shown from Front w/o bumper)

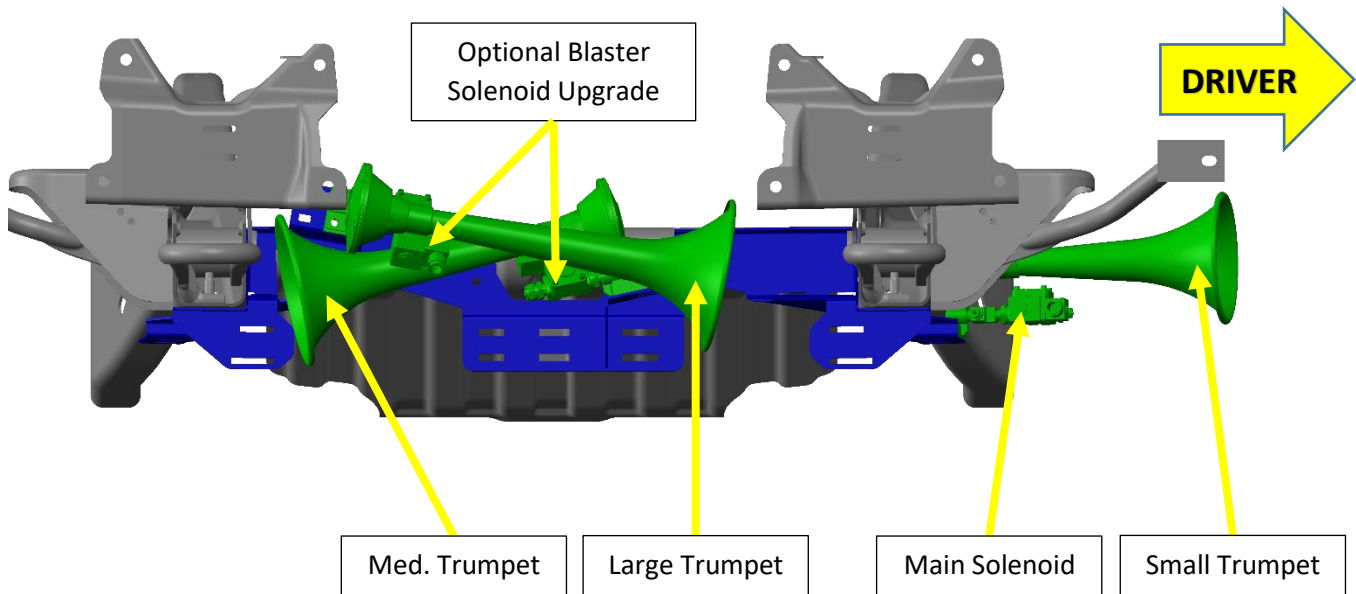

Figure 41 - (2007-2010 ONLY) Air Horn Orientation, 230-KIT, installed (Shown from Front w/o bumper)

10.13. Connect Air Horn to Air Tank

10.13.1. Using supplied Air Tubing, connect Air Horn Solenoid to air fitting, listed as [“To Air Horn”](#) in Air Tank Fitting view above. Properly tighten fittings; ensure tubing is routed away from sharp edges and high heat areas.

10.13.2. Secure air tubing to vehicle with included plastic zip ties.

End of Section



GMHD-230/734/OBA

Installation and Operation Manual

11. Initial Testing of Kit

11.1. Reconnect Vehicle Battery(s)

CAUTION: Before connecting vehicle battery(s), verify all wiring is properly connected and no shorts exists. Use of Multi-Meter, or Test Light is recommended to check continuity of all connections.

11.2. Test Air Compressor

- 11.2.1. Turn vehicle ignition to on position and allow compressor to fill Air Tank. Initial fill may take approximately 2-3 minutes; Air Compressor should shut off automatically once full pressure is achieved.
- 11.2.2. If compressor runs excessively (i.e., 5 minutes or more), disconnect electrical power to Air Compressor and listen for air leaks in system. Repair any problems and retest; contact Kleinn technical support if problem persists.
- 11.2.3. Inspect all air line connections (i.e., Air Tank fittings, Quick Connect fittings, Air Horn fittings, etc.) for leaks by using a soap and water solution sprayed directly onto fittings
- 11.2.4. System must be pressurized or at least Air Compressor running
- 11.2.5. If an air leak is found:
- 11.2.6. Safely release air pressure from system (i.e., slowly open drain valve)
- 11.2.7. Disassemble leaky connection, re-seal and reinstall fittings as needed

11.3. Test Train Horns

- 11.3.1. Allow Air Compressor to run and shut-off automatically (i.e., Air Tank is full)
- 11.3.2. Verify all tubing and electrical wire is securely fastened to vehicle, brackets, or kit parts; if necessary, use extra zip ties to hold tubing and wire in place
- 11.3.3. Ensure all nearby persons have adequate hearing protection and provide courtesy warning to neighbors or others in vicinity

WARNING: NEVER operate train horns with ears close to trumpets or in an enclosed space without substantial hearing protection for all persons closer than 100 feet from vehicle. Never operate train horns outdoors when persons are near vehicle without adequate hearing protection.

- 11.3.4. Briefly activate Horns by pressing Horn Button for one (1) second; repeat three (3) times with a short rest period between (i.e., 1-3 seconds)
- 11.3.5. Horns should sound as expected and be loud; [click to listen to example 230 Kit](#)
- 11.3.6. Horn sound/loudness will taper quickly as Air Tank loses pressure
- 11.3.7. Allow Air Compressor to refill tank, if needed and activate Horns for longer three (3) second period to ensure Horns are functioning properly.

11.4. Test Quick Connect Coupler

- 11.4.1. Allow Air Compressor to refill tank, if needed
- 11.4.2. Attach supplied INF-1 inflator kit to Quick Connect Coupler and verify adequate air pressure is available
- 11.4.3. Test fill tires on vehicle, bicycle, etc.
- 11.4.4. Use Air Blow Gun, Air Impact Gun, and other accessories

End of Section



GMHD-230/734/OBA

Installation and Operation Manual

12. General Operation of Kit

12.1. Compressor Operation

WARNING: *Never operate Air Compressor above its MAXIMUM PRESSURE RATING (see label on body). Operation exceeding maximum pressure will damage Air Compressor and may result in Dangerous Air System failure.*

- 12.1.1. Air compressor is equipped with an automatic thermal overload protection circuit, designed to protect air compressor from overheating and causing permanent damage.
- 12.1.2. Automatic thermal overload protector will automatically reset after 30 minutes.
- 12.1.3. To prevent discharge of vehicle's battery and for best performance, keep vehicle's engine running while using air compressor for any prolonged use (i.e., filling tires, using air tools, etc.).

12.2. Horn Operation

- 12.2.1. Allow Air Compressor to run until it shuts off automatically (i.e., Air Tank is full), or for at least one minute in between horn activations.
- 12.2.2. Press Horn Button to activate Horns
- 12.2.3. Horn sound/loudness will taper quickly as Air Tank loses pressure.
- 12.2.4. Horns should sound for 3-7 seconds depending on kit and tank size

WARNING: *NEVER operate train horns with ears close to trumpets or in an enclosed space without [substantial hearing protection](#) (i.e., > Ear Plugs and Ear Muffs) for all persons closer than 100 feet from vehicle. Never operate train horns outdoors when persons are near vehicle without adequate hearing protection.*

13. Routine Maintenance

Perform following steps at least once during recommended intervals.

- 13.1. Yearly, or every 12000 miles verify all mounting fasteners are properly torqued; applying witness marks across fasteners and mounting parts is good practice to quickly ensure fasteners have not moved.
- 13.2. Yearly, or every 12000 miles remove all road grime and mud from mounting brackets and kit parts using clean water from a garden hose; pay special attention to corners where dirt may collect. Touch up all paint chips using automotive grade enamel in either spray, or brush form.

NOTE: High-pressure washers may damage part finishes and *must* be used with care. Do this more frequently if traveling regularly off-road, or in winter climates where road salts are used.

- 13.3. Yearly, or every 12000 miles check electrical and air fitting connections and wires for abrasion, corrosion, or other damage. Replace damaged components.

NOTE: if system runs continuously or turns on unexpectedly, leaks or intermittent electrical connection may be present.

- 13.4. Monthly, or every 10 hours of compressor run time, drain moisture from air tank using drain valve installed at bottom of tank.

WARNING: *Failure to regularly drain air tank may result in corrosion inside tank and possible failure in tank or air lines, which can suddenly release air pressure causing injury to nearby people.*

- 13.5. Yearly, or every 12000 miles clean, or replace air compressor air filter element. Replacement frequency depends on operating frequency and conditions of operating environment (i.e., daily use of air compressor in dusty, or wet environment requires more frequent filter change).

NOTE: Never lubricate or add any liquids to the included oil-less air compressor