

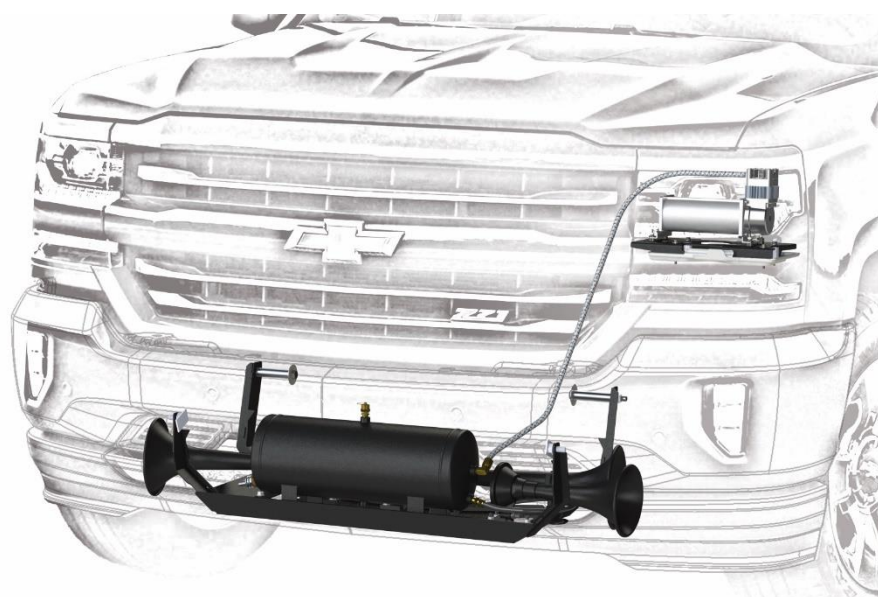

GM1500-230 INSTALLATION MANUAL





GM1500-230

Installation and Operation Manual

This digital PDF is interactive.

Please save ink and paper...



Open interactive manual using Adobe Reader[®]
on PC, MAC, and all smart devices



GM1500-230

Installation and Operation Manual

Table of Contents

1.	How to Use this Manual	5
1.1.	Interactive Manual using Adobe Reader	5
1.2.	Your Kit Part Number and this Manual	5
1.3.	Illustration/Photo Details and Orientation.....	5
2.	Safety First.....	6
3.	Application Chart.....	7
3.1.	100% Direct Bolt-On Vehicle List	7
3.2.	**Excluded Vehicles	7
3.3.	Aftermarket Product Compatibility	7
4.	Kit Installation Overview	8
4.1.	Approximate Installation Time	9
4.2.	***Quick Install Outline.....	9
5.	List of Tools and Supplies	10
5.1.	Standard Tool List (Required).....	10
5.2.	Special Tool List (Recommended)	10
5.3.	Shop Consumables List (Recommended)	10
6.	Parts List	11
6.2.	Pre-Packaged Electro-Mechanical Items.....	11
6.3.	Air Fittings and Related Items	12
6.4.	Electrical Small Components and Related Items.....	14
6.5.	Bolt-On Mounting Brackets & Special Hardware	14
6.6.	Hardware/Fasteners.....	16
7.	On-Vehicle Electrical Installation.....	17
7.1.	Review suggested Wire Routing for Horn, Air Compressor, and Pressure Switch.....	18
7.2.	Disconnect Vehicle Battery(s).....	18
7.3.	Attach Relay to Vehicle.....	19
7.4.	Route Wiring and Install Horn Button	19
7.5.	Connect Relay to Wiring.....	20
7.6.	Connect Air Horn Solenoid	20
7.7.	Pressure Switch	20
8.	Bench Assembly Steps.....	21
8.1.	Disassemble 230 Horn Kit from Box	21



GM1500-230

Installation and Operation Manual

8.2.	Assemble Fittings to Tank.....	21
8.3.	Mount Air Tank to Bracket	22
8.4.	Mount Small, Medium, and Large Horns to Bracket	23
8.5.	Connect Air lines to Tank and Horns	24
9.	On-Vehicle Mechanical Assembly Steps.....	25
9.1.	Compressor and Bracket Installation	25
9.2.	Attach Air Compressor Inlet Filter	28
9.3.	Horn/Tank Assembly Installation	28
9.4.	Connect Air Compressor to Air Tank	32
9.5.	Connect Remote Quick Connect Kit to Vehicle	32
9.6.	Attach Trumpets to Horn Drivers and Tighten	33
10.	Initial Testing of Kit.....	35
10.1.	Reconnect Vehicle Battery(s)	35
10.2.	Test Air Compressor	35
10.3.	Test Train Horns.....	35
10.4.	Test Quick Connect Coupler	35
11.	General Operation of Kit	36
11.1.	Compressor Operation	36
11.2.	Horn Operation.....	36
12.	Routine Maintenance	36



GM1500-230

Installation and Operation Manual

1. How to Use this Manual

1.1. Interactive Manual using Adobe Reader

It is recommended to open this digital PDF using Adobe Reader[®] to take advantage of following key features:

- **Hyperlinks** ([blue underlined text](#)) allow access to additional content via internet; click/tap to activate
 - Includes [Installation Figures](#) and "[Figure xx](#)"
- **Table of Contents** page allows easily navigating this manual; click/tap any section line to go to it
- **Bookmarks** allow quickly navigating to any section; click/tap
- **Zoom IN** on pictures by pressing "CTRL and +" at same time on PC, or pinch in on smart devices
- **Zoom OUT** on pictures by pressing "CTRL and -" at same time on PC, or pinch out on smart devices

To install Adobe Reader[®]

On PC, or Mac

1.2. Your Kit Part Number and this Manual

This manual covers installation, testing, and operation of following kit part numbers

1.2.1. **GM1500-230** (i.e., 230 Train Horns)

NOTE: Illustrations and pictures contained herein may represent only one kit part number. Where critical differences exist between kits (i.e., different parts, orientation, mounting points, etc.), additional text, or necessary graphics are provided to minimize confusion.

Parts list explicitly state kit differences with **(BOLD TEXT)** inside parenthesis, shown below part number.

1.3. Illustration/Photo Details and Orientation

This manual may use digitally created illustrations, and/or actual photos of example vehicle. These graphics may not include exact items found on your vehicle (i.e., electrical wiring, fuel lines, body panels, etc.). Illustrations typically will be missing details and are for clarity to show critical mounting locations and orientation on vehicle.

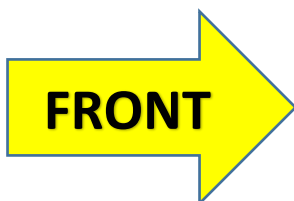

Throughout this manual yellow arrows with text reading "FRONT", may be present over illustrations and pictures. These arrows specify direction toward front of vehicle and provide clarity to how illustration is viewed.



GM1500-230

Installation and Operation Manual

2. Safety First

Read manual thoroughly before starting installation of this kit. Verify you have all parts listed and that you clearly understand this installation procedure. Contact Kleinn technical support for any questions.

Installation of this kit requires **moderate mechanical aptitude**; seek professional help if you're not competent using hand tools in tight uncomfortable spaces, and around possibly rusted and sharp vehicle parts.

Before starting, obtain proper tools required to perform installation correctly, adequate lighting, eye protection, hearing protection for operating train horns, and hand protection to guard against sharp edges and metal burrs, which may be present on kit parts and vehicle parts.

Throughout this manual the following words may be used; be aware of their meaning and application.

CAUTION: means damage could occur to vehicle, or kit parts during, or after installation

WARNING: means injury could occur to you or others, including damage to vehicle, or kit parts

DANGER: means serious injury or death could occur to you or others during installation



GM1500-230

Installation and Operation Manual

3. Application Chart

3.1. 100% Direct Bolt-On Vehicle List

GM1500-230 is a 100% direct bolt-on aftermarket product for GM vehicles listed in below chart; every effort has been made to verify correct fitment on these vehicles in their factory, non-modified conditions.

MODEL YR	MODEL	DRIVE	ENGINE	BODY	TRIM
2007.5-2013	SILVERADO 1500	ALL	ALL	ALL	ALL**
2007.5-2013	SIERRA 1500	ALL	ALL	ALL	ALL**
2016-2018	SILVERADO 1500	ALL	ALL	ALL	ALL**

NOTE: All vehicles listed may require drilling holes for ground wires and installing switches, based on preference of installed switch locations and wire grounding points.

3.2. **Excluded Vehicles

GM1500-230 is NOT compatible with following GM vehicles:

- 3.2.1. 2014-2015 Silverado 1500 with OEM front bumper, due to interference with factory bumper brackets; kit MAY be compatible with aftermarket front bumper
- 3.2.2. 2014-2018 Sierra 1500 with OEM front bumper, due to interference with factory bumper brackets
- 3.2.3. Any vehicle equipped with GM snow plow package, power take off, or factory installed front winch mounted behind front bumper

GM1500-230 could be compatible with following GM vehicles:

- 3.2.4. 2014-2015 Silverado 1500 with aftermarket front bumper, which is designed to fit 2016-2018 vehicles
- 3.2.5. 2014-2018 Sierra 1500 with aftermarket front bumper, which is designed to fit 2016-2018 vehicles

3.3. Aftermarket Product Compatibility

This kit has been designed and tested to be compatible with leading manufacturers of aftermarket truck steps, such as Amp Research Power Steps[®] and all OEM standard and optional steps.

This kit has NOT been designed, or tested for use with leading manufacturers of aftermarket front bumpers.

4. Kit Installation Overview

GM1500-230 consists of following sub-systems, located on vehicle, as follows:

ITEM	DESCRIPTION	MOUNTING LOCATION	APPROX. INSTALL TIME
1	230 Series Large, Medium, and Small Horn with Air Solenoid	Directly behind front bumper. Attached to frame rails.	2+ Hours
2	3 Gal. Air Tank	Directly behind front bumper. Attached to frame rails.	2+ Hours
3	6350RC Air Compressor	Inside Engine Compartment, in secondary battery tray (Driver's Side)	1-2 Hours

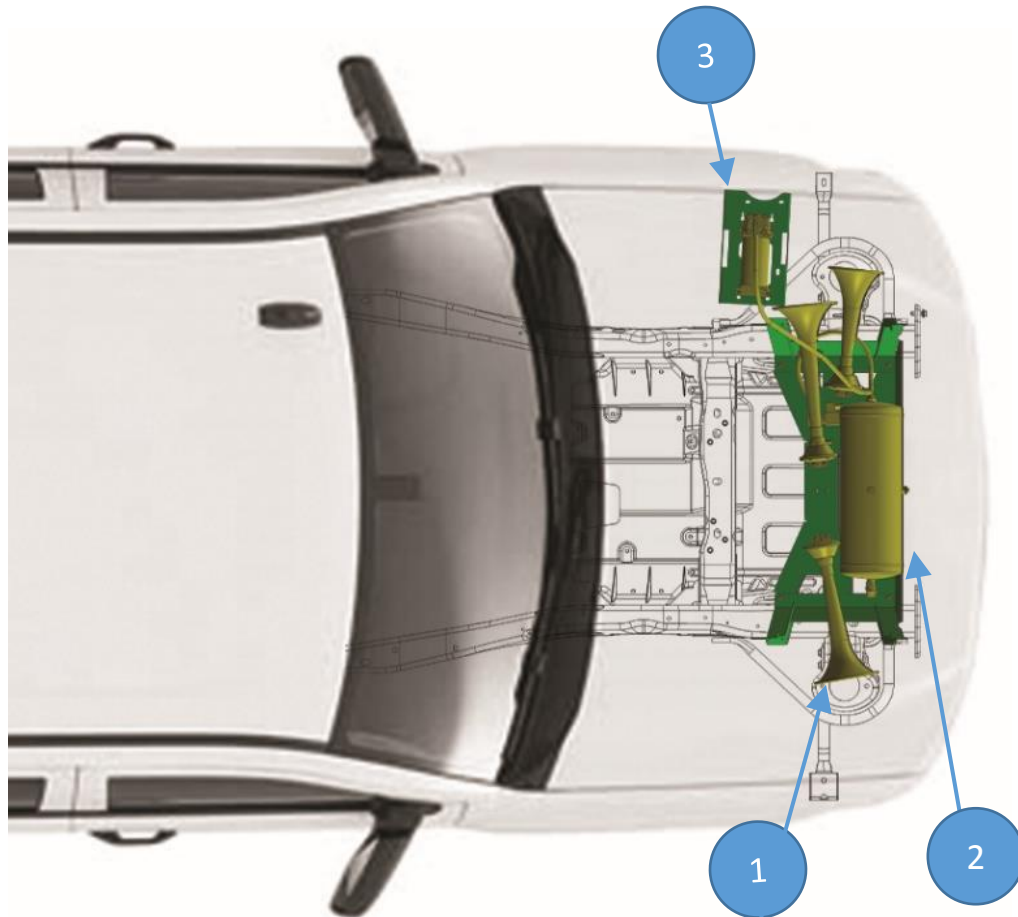

Figure A - Top View Showing Kit Layout



GM1500-230

Installation and Operation Manual

4.1. Approximate Installation Time

GM1500-230 is a multi-faceted product consisting of multiple mechanical, electrical, and pneumatic components.

For a typical home mechanic, auto enthusiast, or technician installing a Kleinn Bolt-On kit for first time, a professional installation job with setup and testing of final product, is estimated to take:

- **6-10 Hours**
-

4.2. ***Quick Install Outline

For person(s) with experience installing Kleinn bolt-on kits, GM1500-230 can be installed in an order similar to below:

1. Route Wiring, install Relay, and install Horn Switch
2. Install Compressor using Compressor Bracket for battery tray
3. Install Compressor Air Filter
4. Install Driver's Side and Passenger's Side Horn Brackets to frame
5. Attach Air Fittings to Air Tank
6. Attach Air Tank Assembly to Horn and Tank Mount, Middle Plate
7. Disassemble 230 Horn Kit (i.e., unscrew Trumpets and separate Horn Drivers)
8. Attach Horn Drivers to Horn and Tank Mount, Middle Plate
9. Install Horn and Tank Mount Assembly to frame brackets
10. Connect Air Compressor Leader Hose, Air Tubing and Wiring to Air Horns and Air Tank Fittings
11. Install Quick Connect Coupler and route Air Tubing
12. Install Trumpets into Horn Drivers
13. Test System and adjust, as needed



GM1500-230

Installation and Operation Manual

5. List of Tools and Supplies

5.1. Standard Tool List (Required)

- 5.1.1. Basic mechanic's 3/8" drive socket sets with extensions
 - Inch Size Sockets (1/4" – 1" Hex)
 - Metric Size Sockets (6mm – 20mm Hex)
- 5.1.2. Basic mechanic's combination wrenches (box/open-end)
 - Inch Size Wrenches (1/4" – 1" Hex)
 - Metric Size Wrenches (6mm – 20mm Hex)
- 5.1.3. Basic mechanic's screwdriver set (Philips, Flat Head)
- 5.1.4. Diagonal Cutter/Wire Cutter Pliers
- 5.1.5. Wire Strippers
- 5.1.6. Wire Terminal Crimpers
- 5.1.7. Slip-Joint Pliers
- 5.1.8. Utility Knife, or Utility Razor blade
- 5.1.9. Magnetic retrieval tool

5.2. Special Tool List (Recommended)

- 5.2.1. 10-100 ft.-lb. torque wrench
- 5.2.2. 20-150 in.-lb. torque wrench
- 5.2.3. Multi-Meter for 12V DC electrical systems, or equivalent
- 5.2.4. 12V DC Test Light, or equivalent
- 5.2.5. Trim Panel Tool, for removing wiring push pins

5.3. Shop Consumables List (Recommended)

- 5.3.1. Quality Electrical tape
- 5.3.2. Di-electric grease for electrical connections
- 5.3.3. Heat Shrink tubing for electrical connections
- 5.3.4. Blue Loctite (i.e., Loctite PN 242), or equivalent
- 5.3.5. Sand Paper, or Wire Brushes for installing ground wires
- 5.3.6. Extra plastic zip ties > 6" long
- 5.3.7. Extra NPT sealant (i.e., Kleinn Air Horn Juice, Teflon tape, etc.)
- 5.3.8. Touch-up paint for frame/chassis
- 5.3.9. Typical cleanup supplies



GM1500-230

Installation and Operation Manual

6. Parts List

Below Parts List covers following kit part numbers:

6.1.1. **GM1500-230** (i.e., 230 Train Horns)

Unpackage and organize Kit across a large work area and verify all parts are included, as listed below. Contact Kleinn support if any questions arise.

6.1.2. Review pre-packaged items (i.e., train horn box, air compressor, air tank, etc.)

6.1.3. Review Air Fittings and Tubing



6.1.4. Review Wiring and Accessories

6.1.5. Review Bolt-On Mounting Brackets

6.1.6. Review Hardware/Fasteners

6.2. Pre-Packaged Electro-Mechanical Items

NOTE: Items in this section come in their own packages and may include additional items inside package

ITEM	QTY	PART NUMBER	DESCRIPTION	PICTURE
1	1	6350RC	6350RC Compressor Kit, with included hardware, and remote air supply line	
2	1	230	230 Series Horn Kit, with included solenoid/valve, and 1/4" Air Tubing, 20 ft. long	



GM1500-230

Installation and Operation Manual

6.3. Air Fittings and Related Items

ITEM	QTY	PART NUMBER	DESCRIPTION	PICTURE
3	1	6350RT	Air Tank, 7-Port	
4	1	51412 (view location on Air Tank)	1/2" NPT X 1/4" Compression Fitting	
5	1	52835 (view location on Air Tank)	1/4" NPT, Drain Valve	
6	1	52175 (view location on Air Tank)	1/4" NPT, 175 PSI Safety Valve	
7	1	50040 (view location on Air Tank)	1/4" NPT Hex Plug	
8	1	51414L (view location on Air Tank)	1/4" NPT X 1/4" Compression Fitting, 90 Deg Elbow	
9	1	2151 (view location on Air Tank)	1/4" NPT Pressure Switch	



GM1500-230

Installation and Operation Manual





10	1	25014	1/4" Air Tubing, 10 ft. long	
11	1	1302	Quick Connect Air Coupler Kit, with relocation bracket	
12	1	INF-1	Inflator Kit, with Air Hose and Bag	
13	1	KLEINN AIR HORN JUICE	Thread Sealant for NPT Fittings	
14	1	30103	KLEINN LEADER HOSE EXTENSION	





GM1500-230

Installation and Operation Manual

6.4. Electrical Small Components and Related Items

ITEM	QTY	PART NUMBER	DESCRIPTION	PICTURE
15	1	320	Terminator – Nickel Plated Remote Horn Button	
16	1	WIRE KIT	Full Wire Kit, with electrical connectors and zip ties	
17	1	¼" WIRE LOOM, 20 ft. Long	1/4" Wire loom for electrical routing	
18	1	1/8" WIRE LOOM, 10 ft. Long	1/8" wire loom for electrical routing	



6.5. Bolt-On Mounting Brackets & Special Hardware

ITEM	QTY	PART NUMBER	DESCRIPTION	PICTURE
19	2	GM-1500-BOLT-TH	FRAME MOUNT BOLT W/ TAB. *USED ONLY ON VEHICLES W/O TOW HOOKS	
20	1	GM1500-BRKT-DR	DRIVER FRAME MOUNT, MAIN SUPPORT BRACKET	

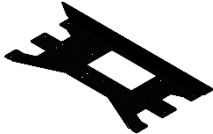

GM1500-230

Installation and Operation Manual

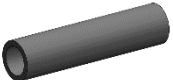
21	1	GM1500-BRKT-PA	PASSENGER FRAME MOUNT, MAIN SUPPORT BRACKET	
22	1	GM1500-BRKT-MD	MAIN TANK & HORN MOUNTING BRACKET	
23	1	GM1500-COMP-BRKT	COMPRESSOR MOUNTING BRACKET (BATTERY TRAY)	
24	2	GM1500-SPCR	FRAME MOUNT BOLT SLEEVE	



GM1500-230

Installation and Operation Manual

6.6. Hardware/Fasteners

ITEM NO.	SIZE, TYPE	DESCRIPTION	WHERE USED	QTY
H1	5/16"-18 X 1", SQUARE NECK BOLT	CARRIAGE BOLT, GRADE 2, ZINC PLATED	HORN MOUNTING (6) BRACKET MOUNTING (6) TANK MOUNTING (4)	16
H2	5/16"-18, LOCK NUT	FLANGED NYLON LOCKNUT, ZINC PLATED	HORN MOUNTING (6) BRACKET MOUNTING (6) TANK MOUNTING (4)	16
H3	5/16", FLAT WASHER	SAE FLAT WASHER, ZINC PLATED	HORN MOUNTING (6) BRACKET MOUNTING (6) TANK MOUNTING (4)	16
H4	5/16" X 1.25", FENDER WASHER	FENDER WASHER, ZINC PLATED	TANK MOUNTING (4)	4
H5	1/2" X 2", FENDER WASHER	FENDER WASHER, ZINC PLATED	BRACKET TO FRAME (2)	2
H6	1/2"-13 X 5", HEX BOLT	HEX BOLT, GRADE 2, ZINC PLATED	BRACKET TO FRAME (2)	2
H7	1/2", FLAT WASHER	SAE FLAT WASHER, ZINC PLATED	BRACKET TO FRAME (2)	2
H8	1/2"-13, LOCK NUT	FLANGED NYLON LOCKNUT, ZINC PLATED	BRACKET TO FRAME (2)	2
H9	10-24 X 1.25", SQUARE NECK BOLT	CARRIAGE BOLT, GRADE 2, ZINC PLATED	COMPRESSOR MOUNTING (4)	4
H10	10-24 HEX NUT	HEX NUT, ZINC-PLATED	COMPRESSOR MOUNTING (4)	4
H11	M6 X 60mm, HEX BOLT	HEX BOLT, GRADE 8.8, ZINC PLATE	COMPRESSOR BRACKET TO BATTERY TRAY (4)	4
H12	M6, LOCK WASHER	SPLIT LOCK WASHER, ZINC PLATED	COMPRESSOR BRACKET TO BATTERY TRAY (4)	4
H13	M6 X 18mm, FENDER WASHER	FENDER WASHER, ZINC PLATED	COMPRESSOR BRACKET TO BATTERY TRAY (4)	4

End of Section

7. On-Vehicle Electrical Installation

CAUTION: Follow all recommended safety precautions for working on vehicle's electrical system; consult vehicle owner's manual for further instruction.

Review Suggested Wiring Diagram for Ignition Relay

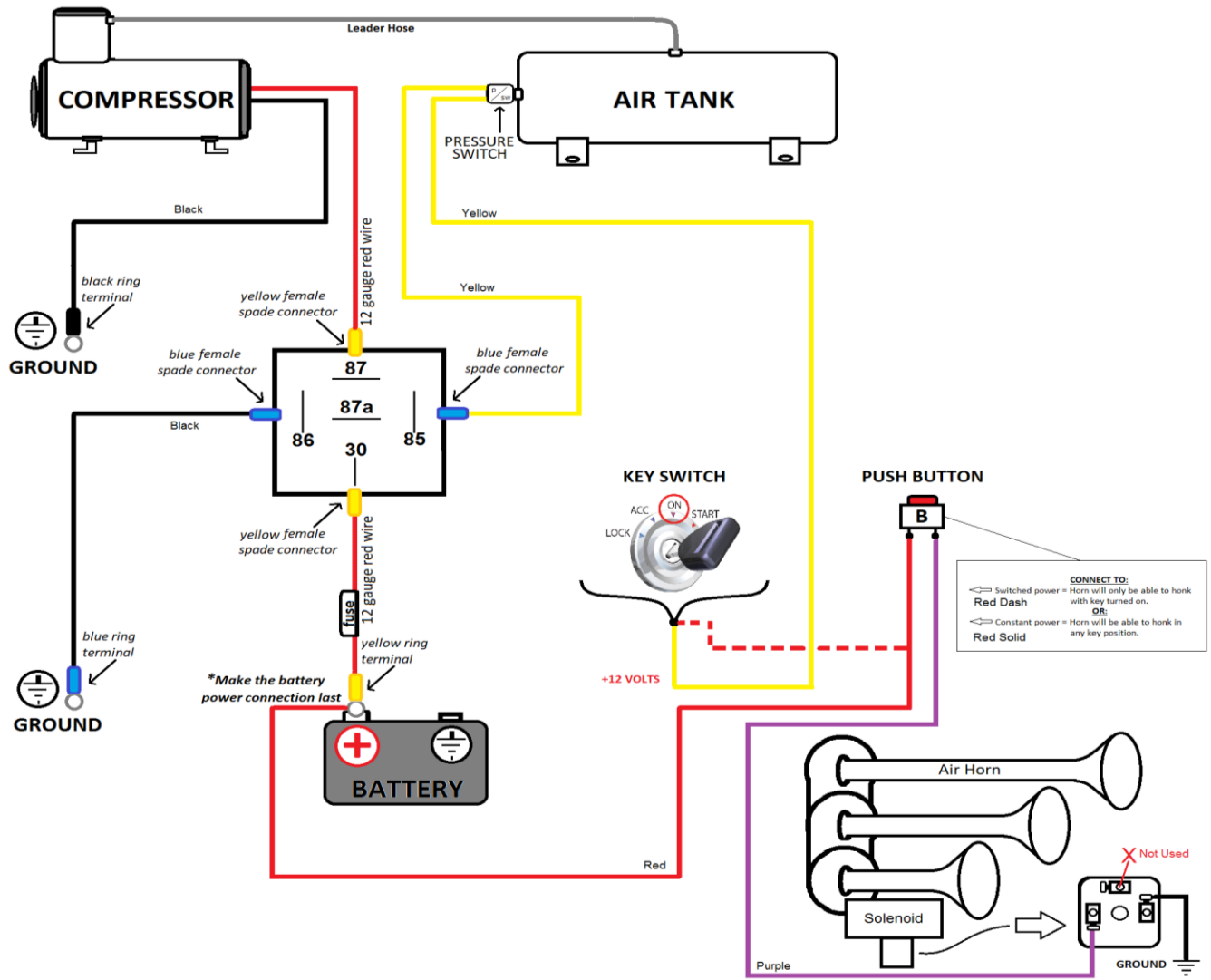

Figure 1 - Suggested Ignition Relay Diagram for 230

7.1. Review suggested Wire Routing for Horn, Air Compressor, and Pressure Switch

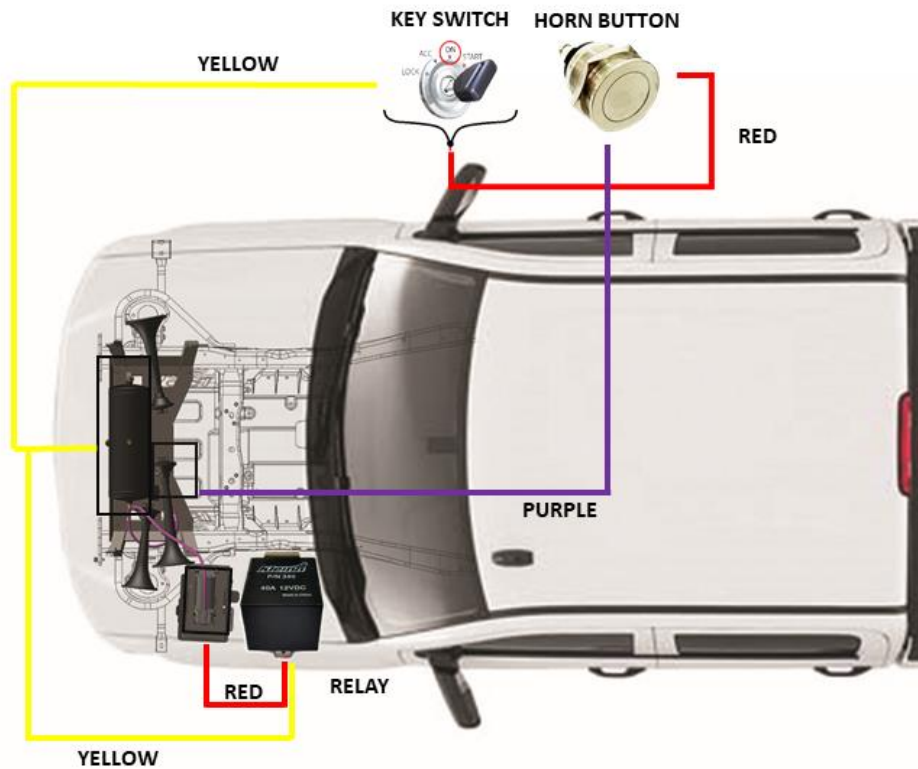

Figure 2 - Suggested Wire Routing for Horn, Air Compressor, and Pressure Switch

7.2. Disconnect Vehicle Battery(s)

7.3. Attach Relay to Vehicle

- 7.3.1. Fasten relay to vehicle body, under hood using supplied self-tapping screws. It is recommended to install in location near factory ground bolt, or battery(s) to minimize drilling holes.

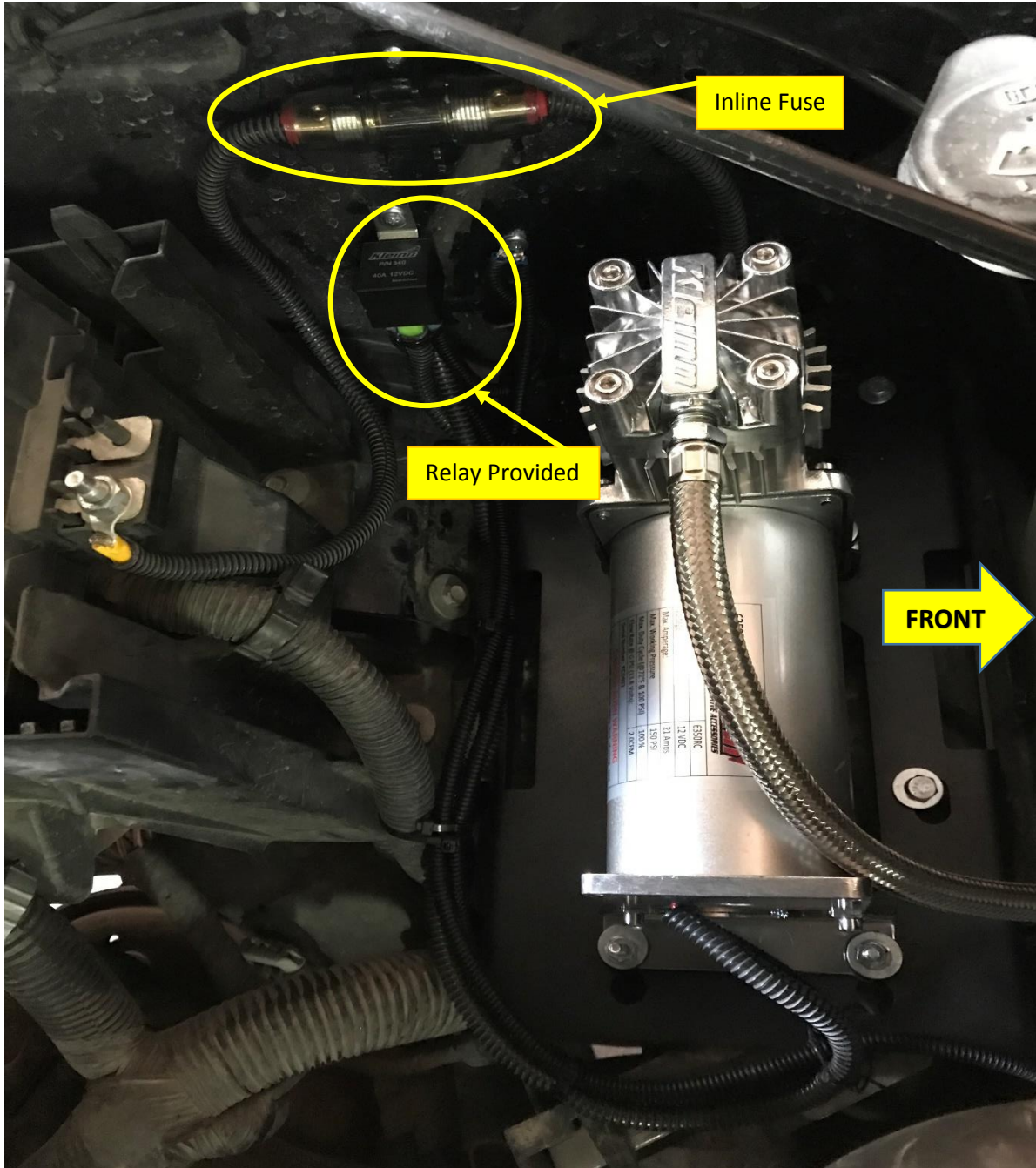

Figure 3 – Compressor Mounted, with Wiring Recommendation

7.4. Route Wiring and Install Horn Button

- 7.4.1. Route wiring throughout vehicle, per diagrams; however, installer may route as desired.
- 7.4.2. Insert all wiring into included wire loom and ensure loom is away from all sharp edges, hot vehicle parts (i.e., exhaust, engine, radiator), and fasten securely to vehicle using zip ties, or equivalent.



GM1500-230

Installation and Operation Manual

NOTE: Do not cut wires to length until 100% sure of length required for final connections.

- 7.4.3. Install supplied fuse holder on end of power wire by cutting the loop in fuse holder and connecting supplied Ring terminal to one end and Butt connector on other end.

CAUTION: *Do not install 30-amp fuse until all electrical connections are final.*

- 7.4.4. Find a suitable location for horn push-button (i.e., in dash, center console, etc.); verify location has 1"+ of clearance behind for terminals. Mark location for drilling.
- 7.4.5. Drill a 3/4" hole at location. Route horn button wires to hole then slide push-button retaining nut over wires and connect per wiring diagram. Install push-button into hole and tighten retaining nut securely on backside.

7.5. Connect Relay to Wiring

- 7.5.1. Connect routed wiring to relay, per wiring diagram.

See Figure 1

7.6. Connect Air Horn Solenoid

- 7.6.1. Vehicle space constraints make it difficult to connect Air Horn Solenoid in-vehicle; therefore, it is recommended to cut and connect a section of wiring to Solenoid during bench assembly, then perform final connection once Air Horn assembly is installed.

7.7. Pressure Switch

- 7.7.1. Vehicle space constraints make it difficult to connect pressure switch in-vehicle; therefore, it is recommended to cut and connect a section of wiring to pressure switch during bench assembly, then perform final connection once Air Tank is installed in vehicle.

End of Section

8. Bench Assembly Steps

Complete following steps off vehicle to facilitate final installation.

NOTE: ALL HARDWARE WILL BE SPECIFIED IN INSTRUCTIONS USING ITEM NO.'S FOUND IN PARTS LIST. [See Parts List](#)

8.1. Disassemble 230 Horn Kit from Box

8.1.1. Unpackage and fully disassemble included train horn kit; train horns must be separated to allow individual installation to bracketry.

8.2. Assemble Fittings to Tank

8.2.1. Apply two small drops of [Kleinn Air Horn Juice](#) to each male pipe thread.

8.2.2. Attach air fittings to tank, per illustrations.

8.2.3. Hand-tighten each fitting, then further tighten each 1/4-1/2 turn using proper sized box-end wrench; adjust as necessary to match fitting orientation shown.

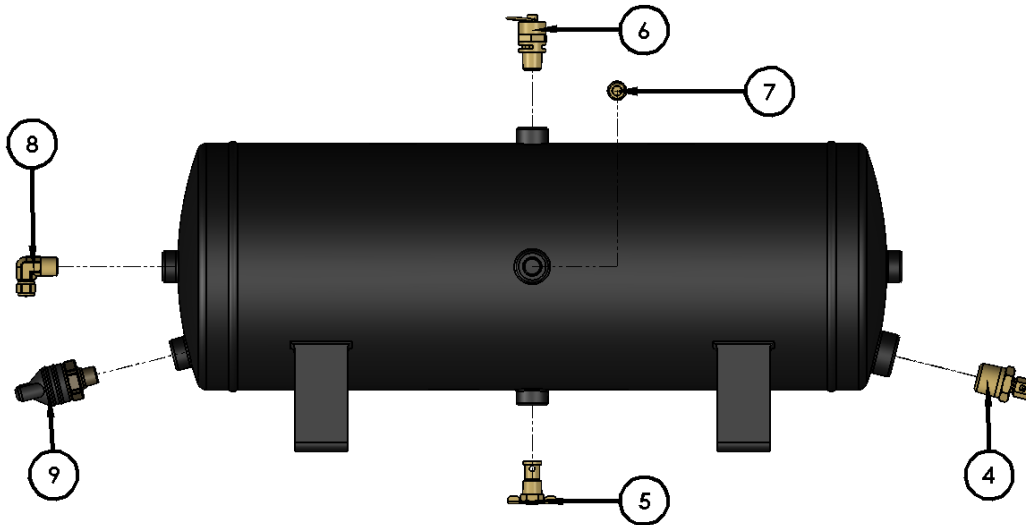

Figure 4 - Fitting Locations on Air Tank

8.3. Mount Air Tank to Bracket

- 8.3.1. Using H1, H2, H3 & H4, prepare to mount the Tank to the GM1500-BRKT-MD bracket.
- 8.3.2. Assemble fasteners clean and dry using proper socket and box-end wrench.
- 8.3.3. Perform final bolt-tightening on Air Tank, torquing each bolt to 75 in-lbs.

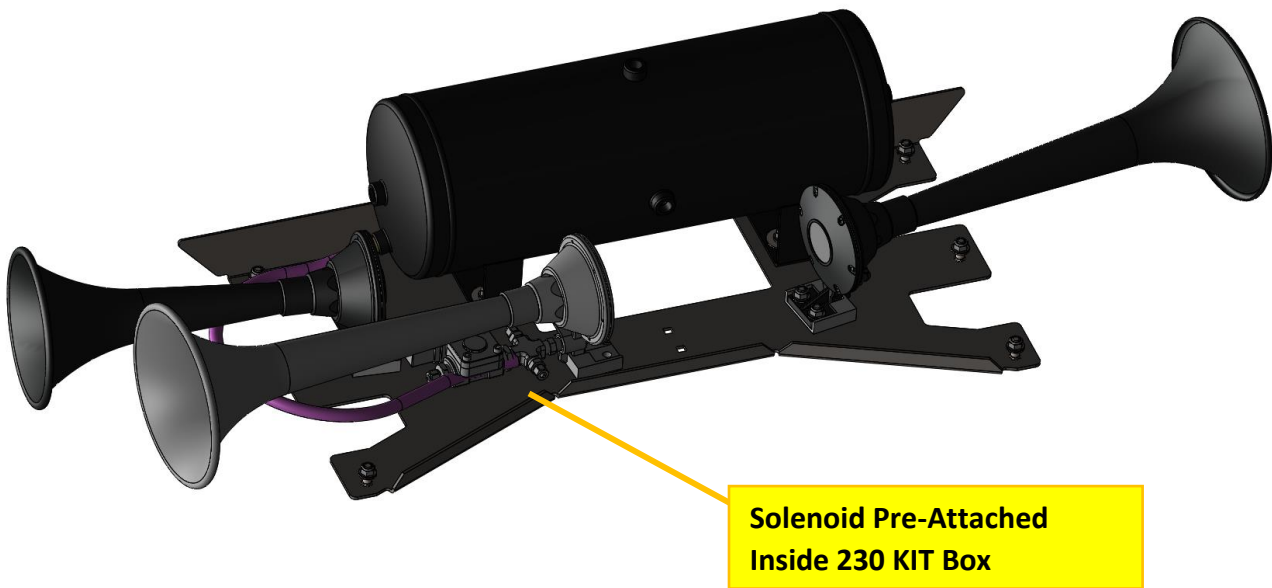

Figure 5 – Bench Assembly

Torque AIR TANK & Horn Driver nuts
to 75 IN-LBS

*After Bracket is **INSTALLED**

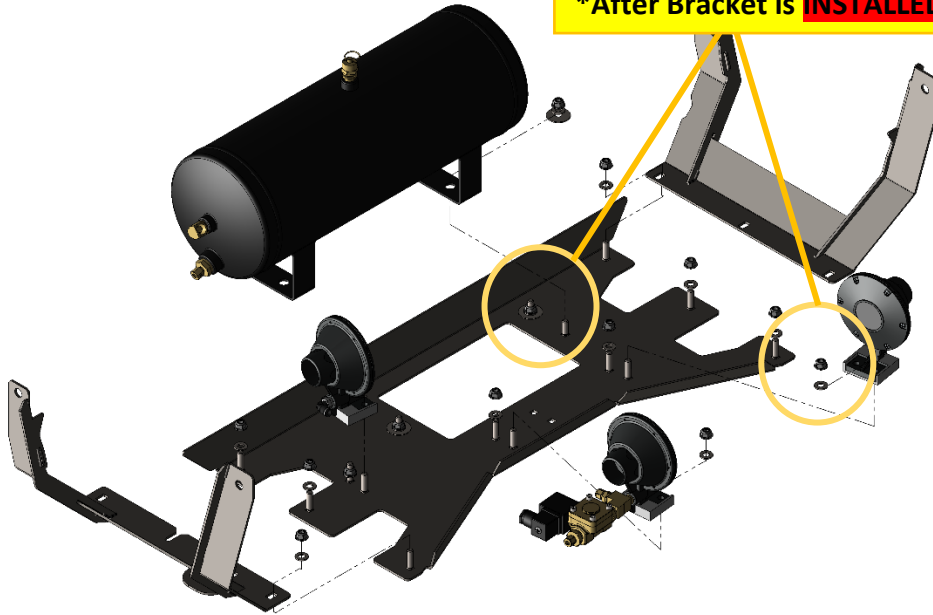

Figure 6 - Final Torque of Horn Driver Bolts and Air Tank (Trumpets not shown for clarity)

8.4. Mount Small, Medium, and Large Horns to Bracket

- 8.4.1. Attach Horn Drivers to GM1500-BRKT-MD, per illustration.
- 8.4.2. Trumpets should **not** be connected to drivers.
- 8.4.3. Use H1, H2 & H3.

[See figure 5, 6](#)

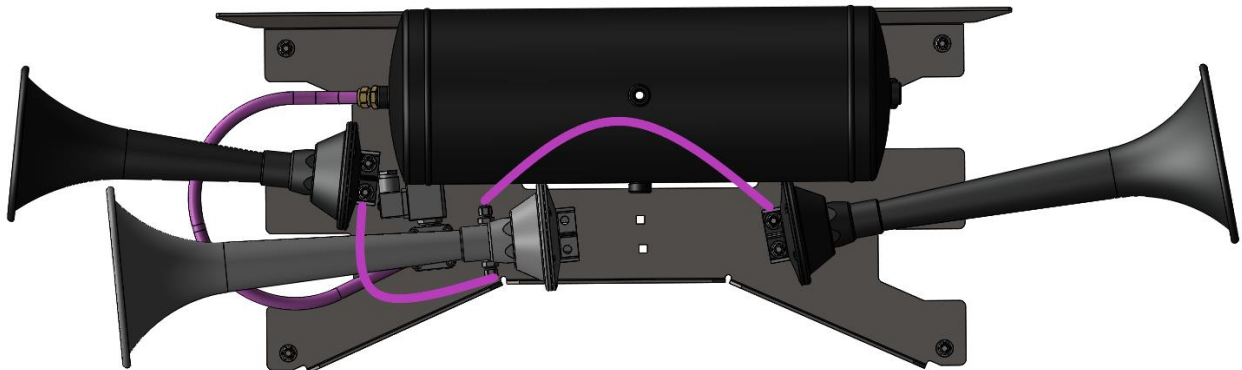

Figure 7 – Bracket with Drivers & Air Line example between Horn Drivers



GM1500-230

Installation and Operation Manual

8.5. Connect Air lines to Tank and Horns

- 8.5.1. Connect Horn Solenoid directly to Air Tank, using 1/4" air line.
- 8.5.2. Connect both Small and Medium horns directly to "T" fitting on Large horn.
- 8.5.3. Attach air tubing to tank from Air Horn Solenoid; space constraints exist during tank installation increasing difficulty of this step.

[See Figure 7](#)

End of Section

9. On-Vehicle Mechanical Assembly Steps

Complete following steps *on vehicle*.

Raise vehicle off ground using appropriate vehicle lift, ramps, or jack stands.

DANGER: Installation requires being underneath vehicle and applying forces to vehicle chassis. Follow all recommended safety precautions for raising vehicle; consult vehicle owner's manual.

9.1. Compressor and Bracket Installation

9.1.1. Locate battery tray on Driver's side of vehicle.

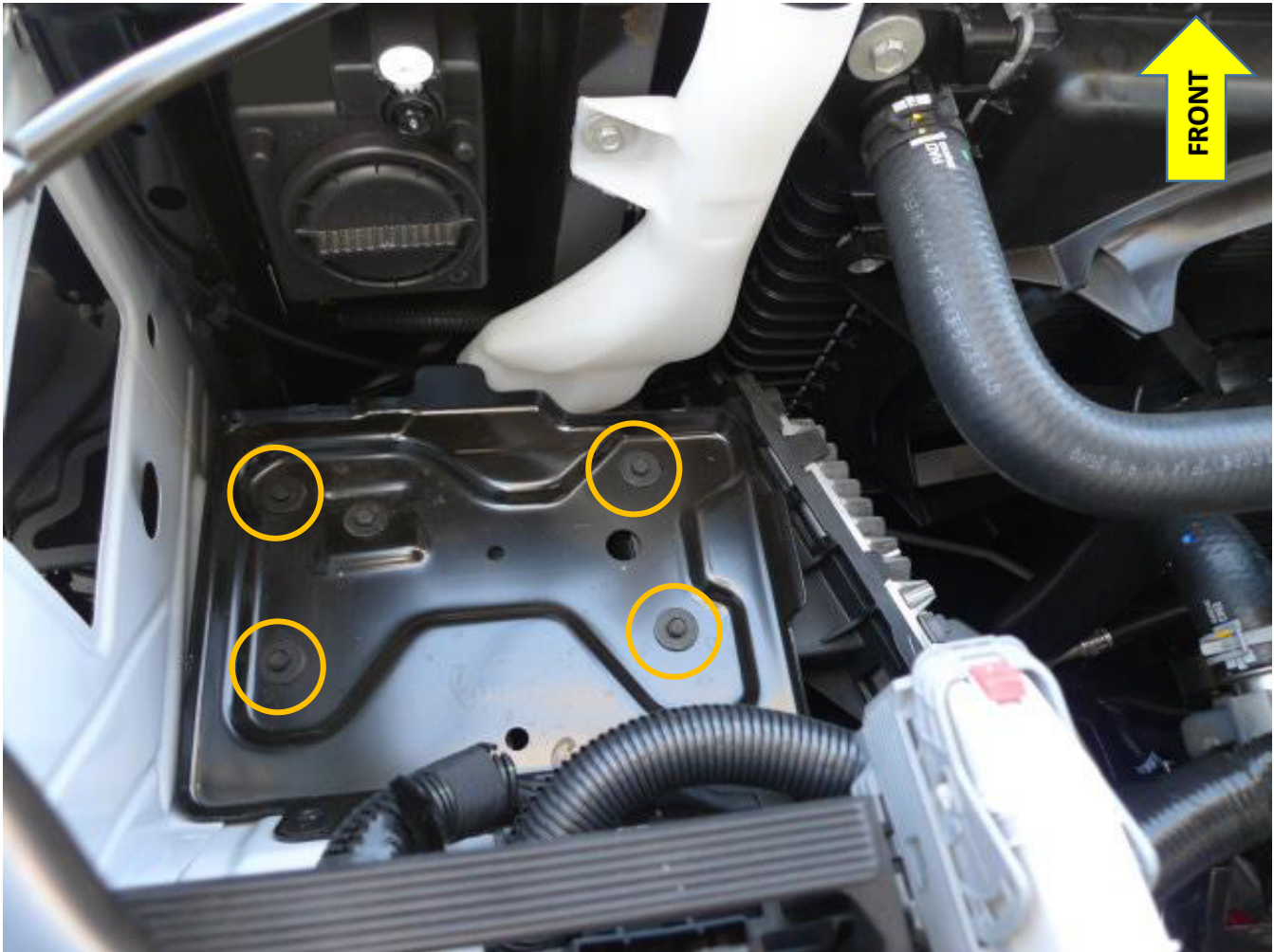

Figure 8 – GM1500-COMP-BRKT Mounting holes (Remove Factory Bolts)

- 9.1.2. Remove 4 bolts holding in the stock battery tray.
- 9.1.3. Attach GM1500-COMP-BRKT
- 9.1.4. Use H11, H12 & H13.
- 9.1.5. Assemble fasteners clean and dry using proper socket and box-end wrench.
- 9.1.6. Torque each bolt to 60 in-lbs.

- 9.1.7. Apply two small drops of [Kleinn Air Horn Juice](#) to the male pipe thread on the compressor hose.
- 9.1.8. Attach the leader hose extension.

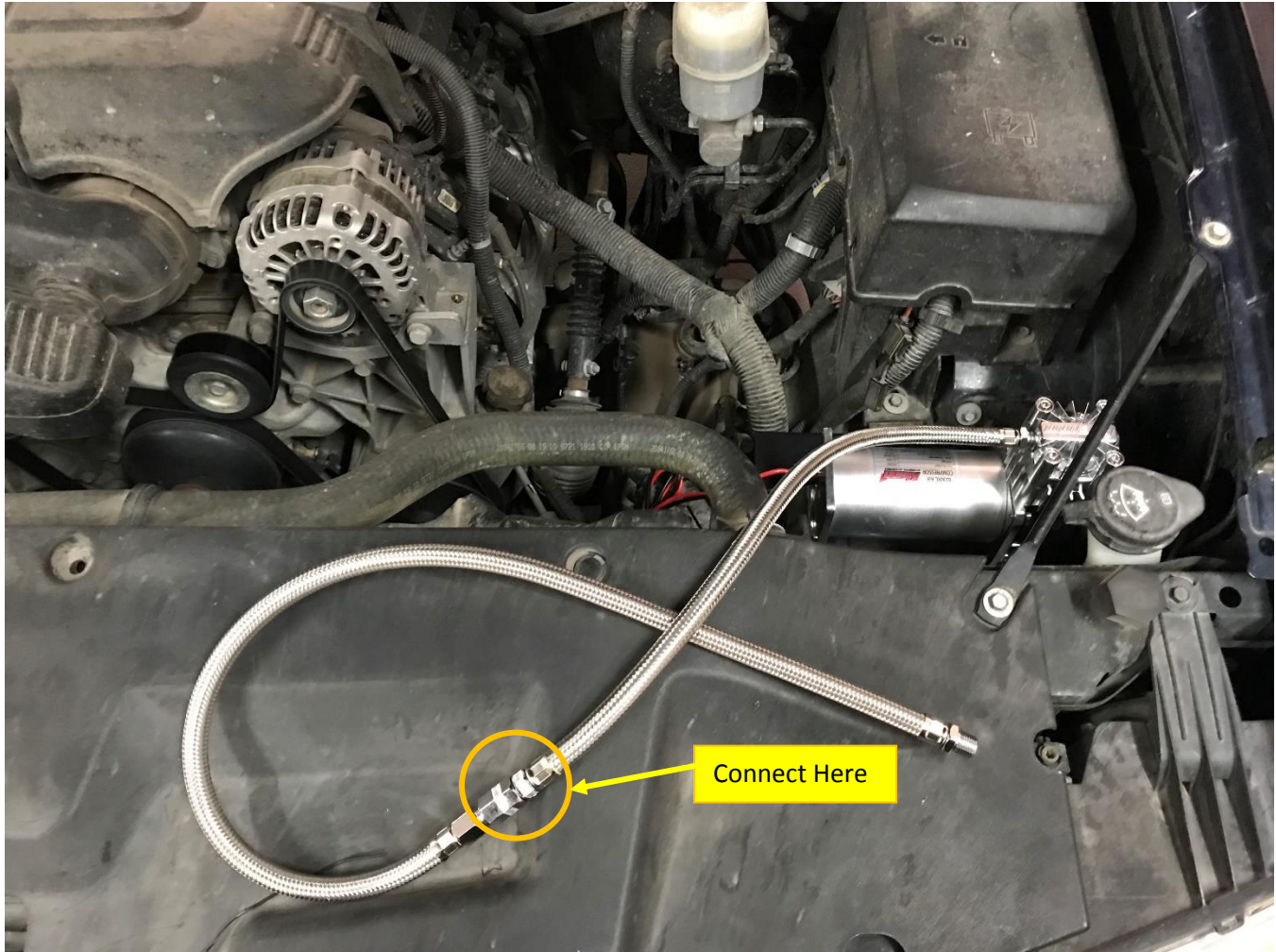

Figure 9 - Leader Hose Extension Installed

- 9.1.9. Route air line straight down towards factory skid plate.
- 9.1.10. Mount the Compressor to GM1500-COMP-BRKT.
- 9.1.11. Use H9 & H10.

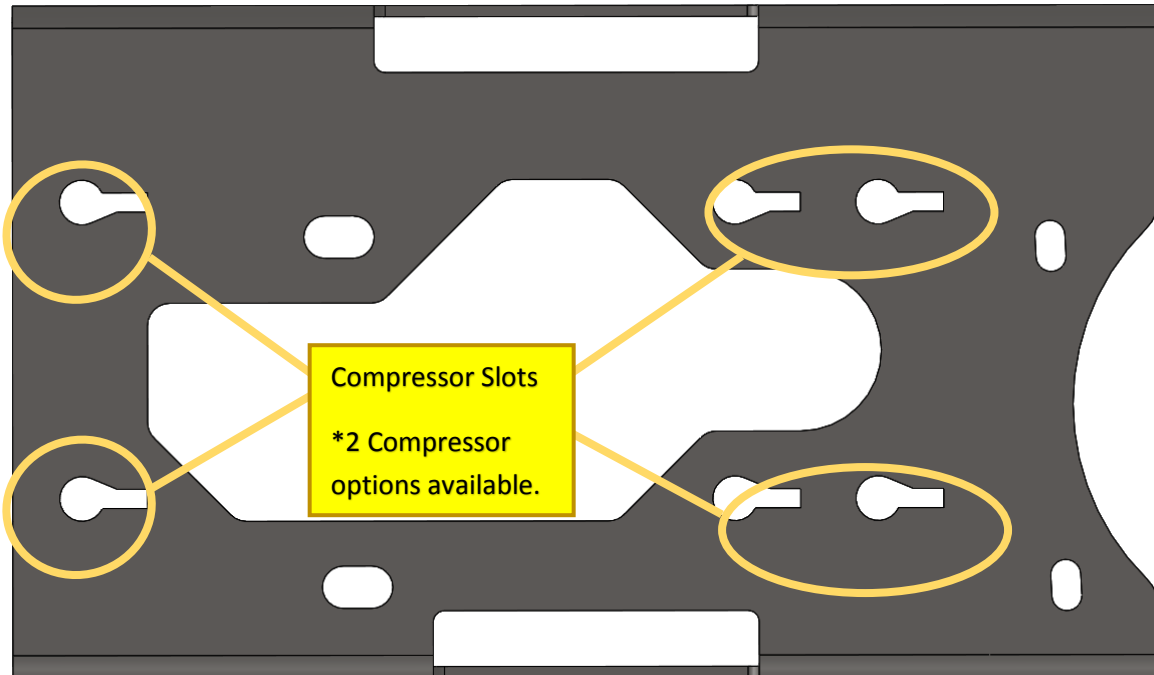

Figure 10 – Figure Compressor Slots Shown, for Proper Carriage Bolt Alignment.

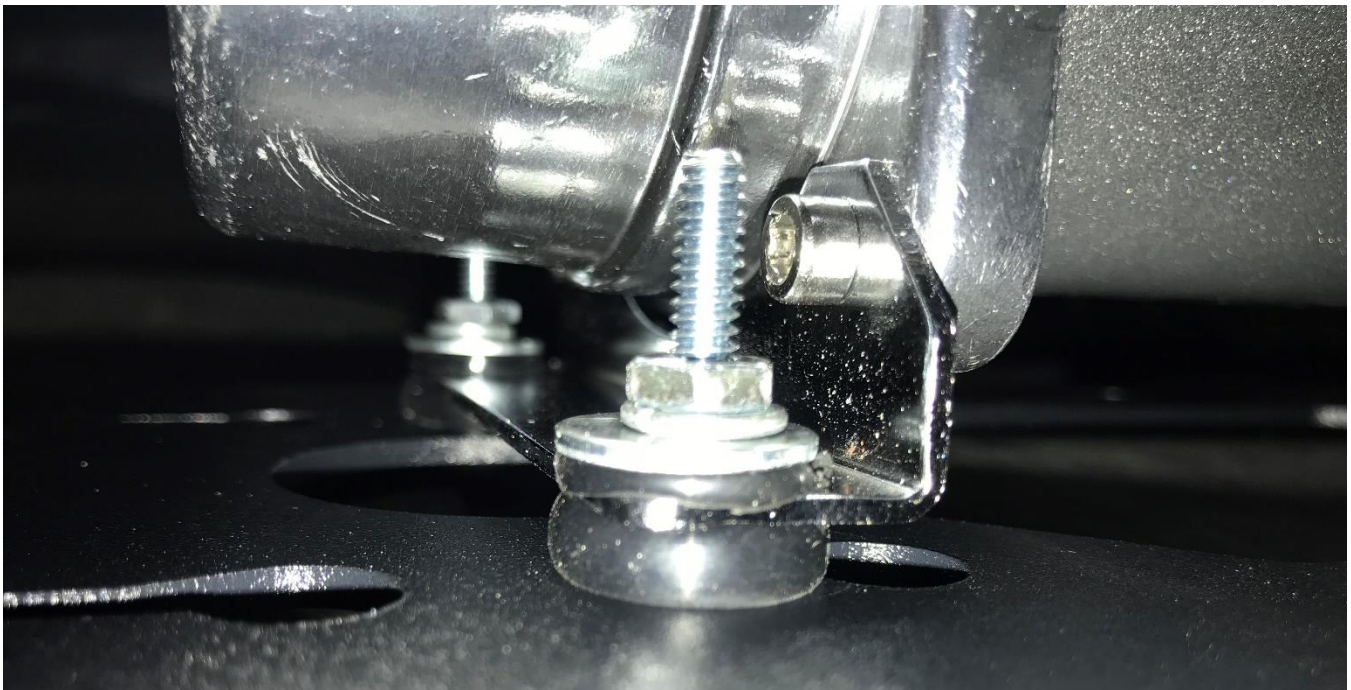

Figure 11 – Compressor Carriage Bolts attached.

NOTE: For ease of install, insert each carriage bolt into the compressor, and loosely attach nuts w/ washers. Then lower the compressor, with ALL 4 carriage bolts loosely attached, into allotted slots in Bracket.

10.3.5 Tighten all the hardware to 25 in-lbs.

9.2. Attach Air Compressor Inlet Filter

- 9.2.1. Pry-open plastic air filter housing and install foam filter inside.
- 9.2.2. Using included fittings, attached filter housing to front input of Air Compressor, or route and attach filter remotely, as desired.

9.3. Horn/Tank Assembly Installation

- 9.3.1. Locate bolts towards the front of each frame rail.

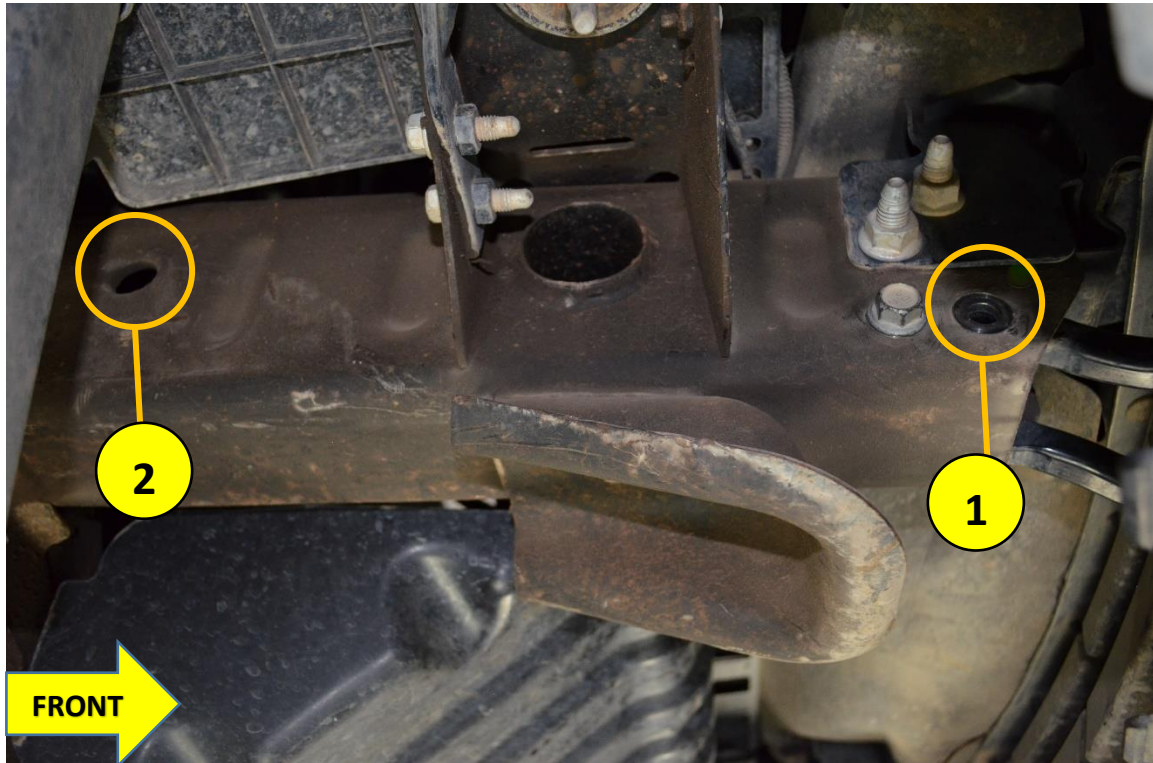

Figure 12 – Frame Attachment Points (Passenger Side)

- 9.3.2. Remove front-most bolt on frame rail.
- 9.3.3. *IF **EQUIPPED** WITH TOW HOOKS* Reuse tow hook bolt to secure bracket to the outside of the frame rail.
- 9.3.4. *IF **NOT EQUIPPED** WITH TOW HOOKS* Insert BOLT-TH's into the frame rails, so threads are protruding to the outside of the vehicle.

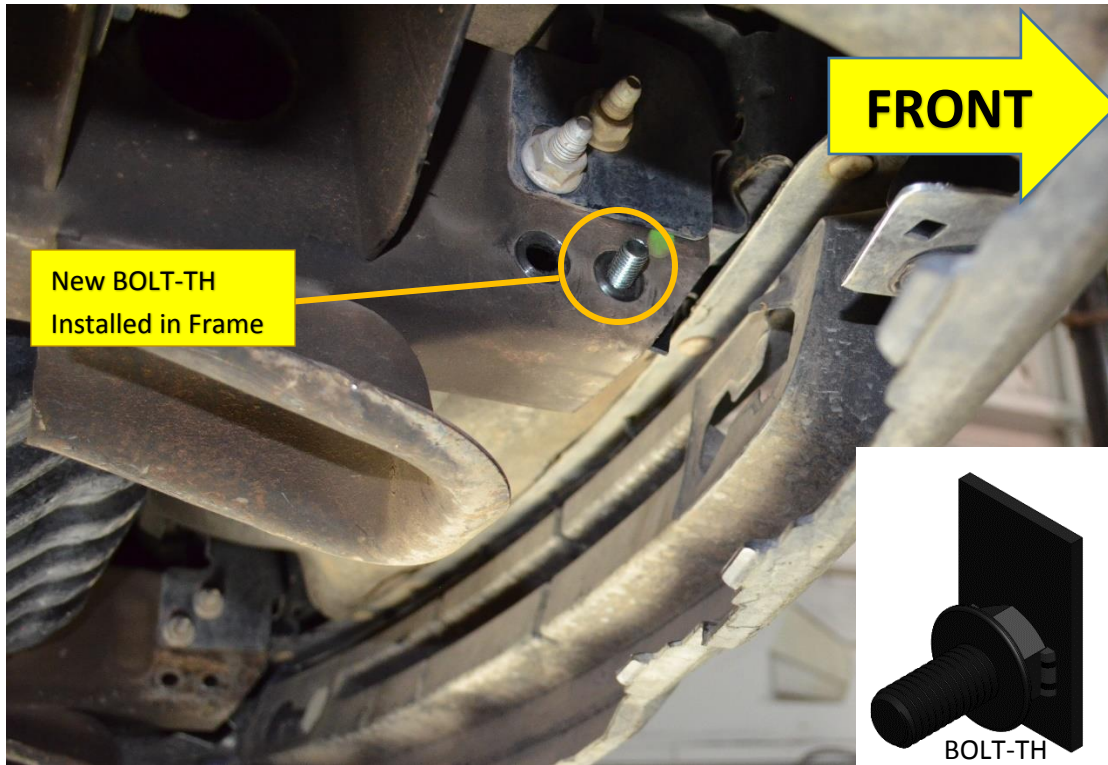

Figure 13 - BOLT-TH Installation in Frame Rails (Passenger Side)

- 9.3.5. Hang GM1500-BRKT-PA from BOLT-TH or Stock Tow Hook bolt.
- 9.3.6. Verify GM1500-BRKT-PA aligns with large rear hole, per Fig 12.
- 9.3.7. Insert GM1500-SPCR into this frame hole, from inside of frame rail.
- 9.3.8. Using H8, H9, H10 & H11 mount the rear of the bracket to the frame.

NOTE: H8 Washers are inserted on the *inside* of frame rails, IE: Not on the side facing the outside of the vehicle.



Figure 14 - Bracket Installation to Frame Rail (Passenger Side)

9.3.9. Repeat procedure on Driver side of the vehicle, using GM1500-BRKT-DR



Figure 15 - Frame Rail Attachment Points (Driver Side)



Figure 16 - Bracket Attached to Frame Rail (Driver Side)

- 9.3.10. Prepare H1, H2 & H3 for installation of GM1500-BRKT-MD.
- 9.3.11. Attach one carriage bolt with washer and nut loosely attached to the Driver side center bolt hole.
- 9.3.12. Raise bracket into place, using the single bolt installed to slide into the slot in GM1500-BRKT-DR.
- 9.3.13. Slot showcased in Figure 17 below.

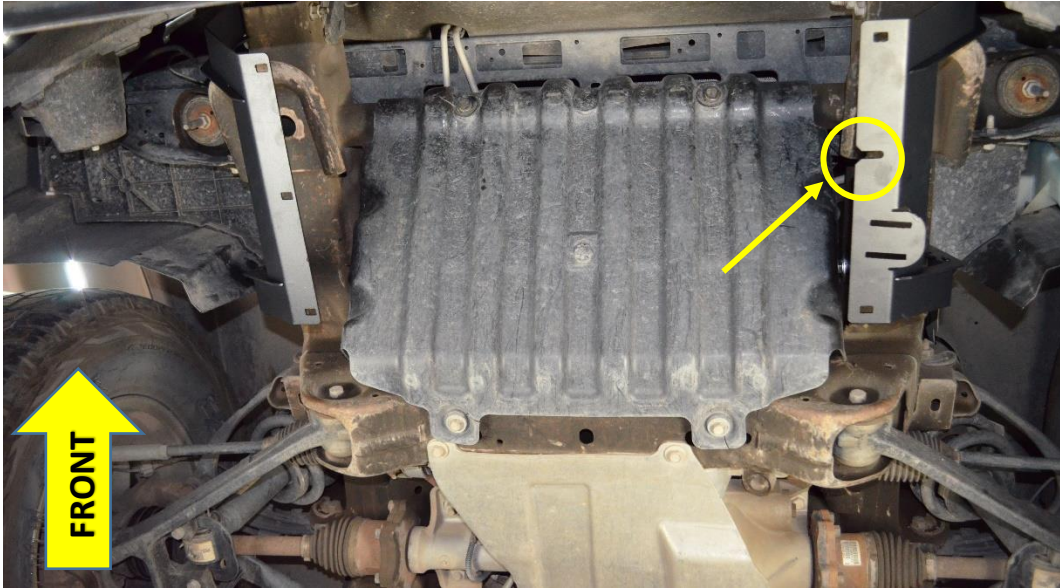

Figure 17 - Underside of Vehicle, with Brackets Mounted

- 9.3.14. While bracket is hanging from support bolt, install the remaining 5 bolts, washers and nuts loosely.
- 9.3.15. Ensure washers are *not* installed in between brackets, and are instead on *TOP* of all.
- 9.3.16. Tighten all hardware to 75 in-lbs.

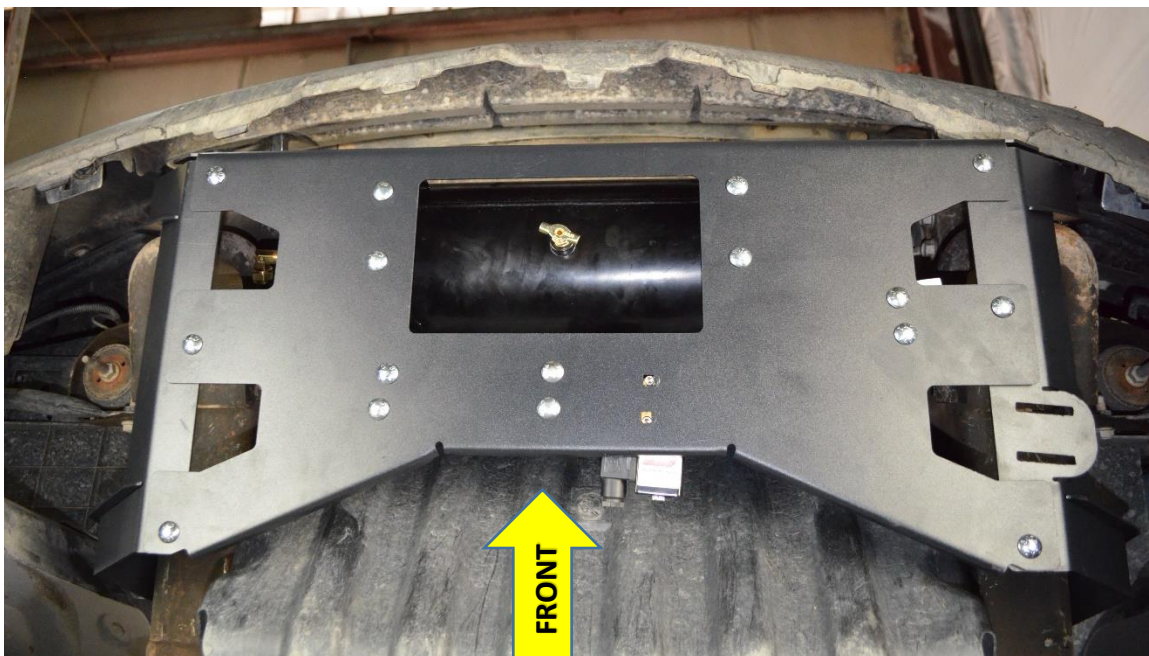

Figure 18 - Middle Plate Installed

9.4. Connect Air Compressor to Air Tank

- 9.4.1. Connect compressor leader extension hose to the Air tank using the last available port; see Fig 19.
- 9.4.2. Apply two small drops of [Kleinn Air Horn Juice](#) to each male pipe thread.

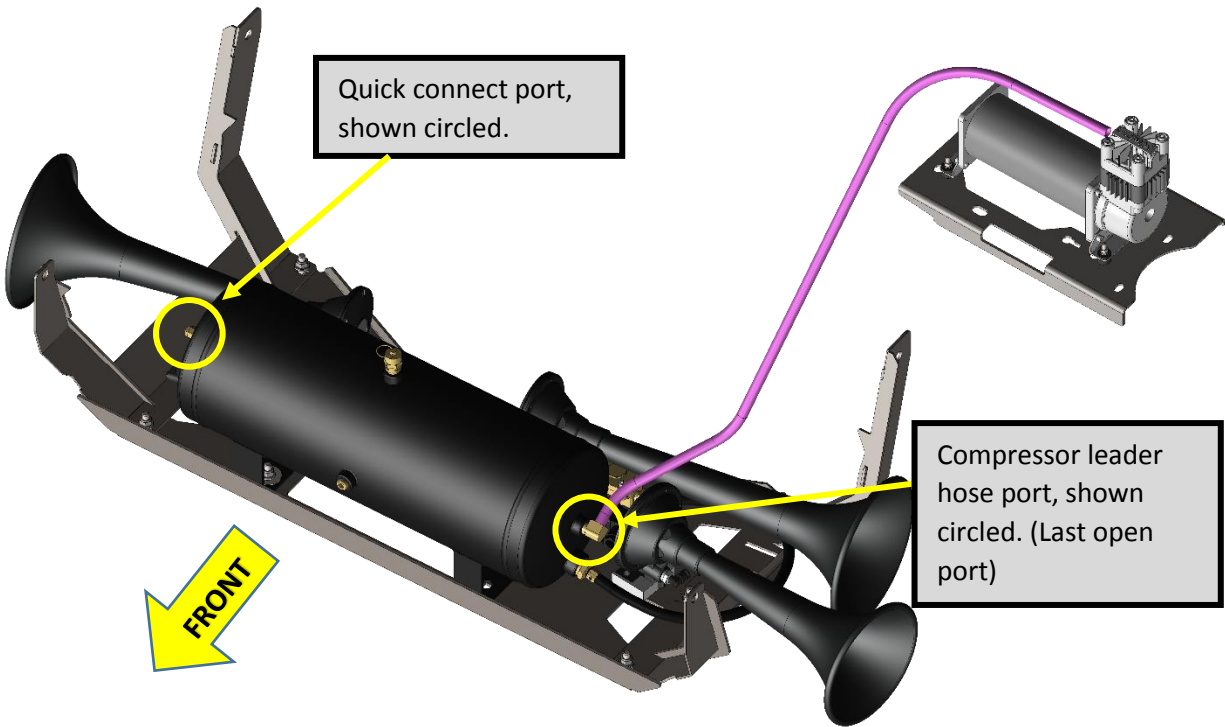

Figure 19 - Compressor to Air Tank Line

9.5. Connect Remote Quick Connect Kit to Vehicle

- 9.5.1. Route and attach Quick Connect Coupler Kit to vehicle, as desired using attachment bracket and self-drilling fasteners, supplied in Coupler package
- 9.5.2. Use supplied 1/4" tubing and attach to port shown above

Some optional locations include under hood, near grill, behind bumper, in bed rail, etc.



Figure 19 - Compressor to Air Tank Line

9.6. Attach Trumpets to Horn Drivers and Tighten

- 9.6.1. Install trumpets into horn drivers and tighten them snugly, per below illustrations.
 - 9.6.1.1. Medium Trumpet (Passenger Side)
 - 9.6.1.2. Large Trumpet (Driver Side)
 - 9.6.1.3. Small Trumpet (Driver Side)
- 9.6.2. Position trumpets to maintain a minimum 1/4" of clearance between vehicle and kit brackets.
- 9.6.3. With trumpets positioned, tighten & torque horn drivers to 75 in-lbs.



Figure 21 - Install Medium Trumpet between Frame and Plate (Passenger Side)

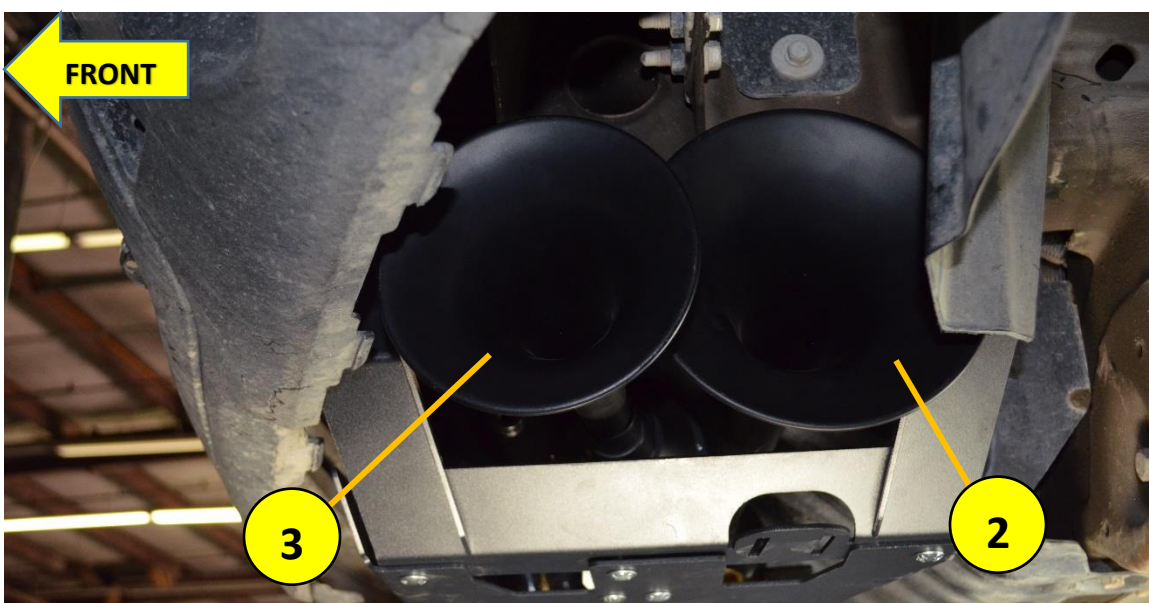

Figure 22 - Install Large, and Small Trumpets (Driver Side)



Figure 23 - Trumpets Installed before Wiring/Plumbing

End of Section



GM1500-230

Installation and Operation Manual

10. Initial Testing of Kit

10.1. Reconnect Vehicle Battery(s)

CAUTION: Before connecting vehicle battery(s), verify all wiring is properly connected and no shorts exists. Use of Multi-Meter, or Test Light is recommended to check continuity of all connections.

10.2. Test Air Compressor

- 10.2.1. Turn vehicle ignition to on position and allow compressor to fill Air Tank. Initial fill may take approximately 1.5-3 minutes; Air Compressor should shut off automatically once full pressure is achieved.
- 10.2.2. If compressor runs excessively (i.e., 5 minutes or more), disconnect electrical power to Air Compressor and listen for air leaks in system. Repair any problems and retest; contact Kleinn technical support if problem persists.
- 10.2.3. Inspect all air line connections (i.e., Air Tank fittings, Quick Connect fittings, Air Horn fittings, etc.) for leaks by using a soap and water solution sprayed directly onto fittings
- 10.2.4. System must be pressurized or at least Air Compressor running
- 10.2.5. If an air leak is found:
- 10.2.6. Safely release air pressure from system (i.e., slowly open drain valve)
- 10.2.7. Disassemble leaky connection, re-seal and reinstall fittings as needed

10.3. Test Train Horns

- 10.3.1. Allow Air Compressor to run and shut-off automatically (i.e., Air Tank is full)
- 10.3.2. Verify all tubing and electrical wire is securely fastened to vehicle, brackets, or kit parts; if necessary, use extra zip ties to hold tubing and wire in place
- 10.3.3. Ensure all nearby persons have adequate hearing protection and provide courtesy warning to neighbors or others in vicinity

WARNING: NEVER operate train horns with ears close to trumpets or in an enclosed space without substantial hearing protection (i.e., > Ear Plugs and Ear Muffs) for all persons closer than 100 feet from vehicle. Never operate train horns outdoors when persons are near vehicle without adequate hearing protection.

- 10.3.4. Briefly activate Horns by pressing Horn Button for one (1) second; repeat three (3) times with a short rest period between (i.e., 1-3 seconds)
- 10.3.5. Horns should sound as expected and be loud; click to listen to example 230 Kit
- 10.3.6. Horn sound/loudness will taper quickly as Air Tank loses pressure
- 10.3.7. Allow Air Compressor to refill tank, if needed and activate Horns for longer three (3) second period to ensure Horns are functioning properly.

10.4. Test Quick Connect Coupler

- 10.4.1. Allow Air Compressor to refill tank, if needed
- 10.4.2. Attach supplied INF-1 inflator kit to Quick Connect Coupler and verify adequate air pressure is available
- 10.4.3. Test fill tires on vehicle, bicycle, etc.
- 10.4.4. Use Air Blow Gun
- 10.4.5. Use Air Impact Gun

End of Section



GM1500-230

Installation and Operation Manual

11. General Operation of Kit

11.1. Compressor Operation

WARNING: *Never operate Air Compressor above its MAXIMUM PRESSURE RATING (see label on body). Operation exceeding maximum pressure will damage Air Compressor and may result in Dangerous Air System failure.*

- 11.1.1. Air compressor is equipped with an automatic thermal overload protection circuit, designed to protect air compressor from overheating and causing permanent damage.
- 11.1.2. Automatic thermal overload protector will automatically reset after 30 minutes.
- 11.1.3. To prevent discharge of vehicle's battery and for best performance, keep vehicle's engine running while using air compressor for any prolonged use (i.e., filling tires, using air tools, etc.).

11.2. Horn Operation

- 11.2.1. Allow Air Compressor to run until it shuts off automatically (i.e., Air Tank is full), or for at least one minute in between horn activations.
- 11.2.2. Press Horn Button to activate Horns
- 11.2.3. Horn sound/loudness will taper quickly as Air Tank loses pressure.
- 11.2.4. Horns should sound for 3-7 seconds depending on kit and tank size

WARNING: *NEVER operate train horns with ears close to trumpets or in an enclosed space without [substantial hearing protection](#) (i.e., > Ear Plugs and Ear Muffs) for all persons closer than 100 feet from vehicle. Never operate train horns outdoors when persons are near vehicle without adequate hearing protection.*

12. Routine Maintenance

Perform following steps at least once during recommended intervals.

- 12.1. Yearly, or every 12000 miles verify all mounting fasteners are properly torqued; applying witness marks across fasteners and mounting parts is good practice to quickly ensure fasteners have not moved.
- 12.2. Yearly, or every 12000 miles remove all road grime and mud from mounting brackets and kit parts using clean water from a garden hose; pay special attention to corners where dirt may collect. Touch up all paint chips using automotive grade enamel in either spray, or brush form.

NOTE: High-pressure washers may damage part finishes and *must* be used with care. Do this more frequently if traveling regularly off-road, or in winter climates where road salts are used.

- 12.3. Yearly, or every 12000 miles check electrical and air fitting connections and wires for abrasion, corrosion, or other damage. Replace damaged components.

NOTE: if system runs continuously or turns on unexpectedly, leaks or intermittent electrical connection may be present.

- 12.4. Monthly, or every 10 hours of compressor run time, drain moisture from air tank using drain valve installed at bottom of tank.

WARNING: *Failure to regularly drain air tank may result in corrosion inside tank and possible failure in tank or air lines, which can suddenly release air pressure causing injury to nearby people.*

- 12.5. Yearly, or every 12000 miles clean, or replace air compressor air filter element. Replacement frequency depends on operating frequency and conditions of operating environment (i.e., daily use of air compressor in dusty, or wet environment requires more frequent filter change).

NOTE: Never lubricate or add any liquids to the included oil-less air compressor