

KMA
AMPLIFIERS
Owner's Manual

KMA150.2
KMA300.4
KMA450.6

MODEL:

KMA150.2 | KMA300.4 | KMA450.6

IMPORTANT SAFETY WARNING

PROLONGED CONTINUOUS OPERATION OF AN AMPLIFIER, SPEAKER, OR SUBWOOFER IN A DISTORTED, CLIPPED OR OVER-POWERED MANNER CAN CAUSE YOUR AUDIO SYSTEM TO OVERHEAT, POSSIBLY CATCHING FIRE AND RESULTING IN SERIOUS DAMAGE TO YOUR COMPONENTS AND/OR VEHICLE. AMPLIFIERS REQUIRE UP TO 4 INCHES (10CM) OPEN VENTILATION. SUBWOOFERS SHOULD BE MOUNTED WITH AT LEAST 1 INCH (2.5CM) CLEARANCE BETWEEN THE FRONT OF THE SPEAKER AND ANY SURFACE.

PERFORMANCE

Model:	KMA150.2	KMA300.4	KMA450.6
RMS Power			
@ 14.4V, 4Ω stereo, ≤ 1% THD+N	40 x 2	40 x 4	40 x 6
@ 14.4V, 2Ω stereo, ≤ 1% THD+N	75 x 2	75 x 4	75 x 6
@ 14.4V, 4Ω mono, ≤ 1% THD+N	150 x 1	150 x 2	150 x 3
Length [in, cm]	8-1/16, 20.4	12-7/16, 31.5	13-15/16, 35.3
Height [in, cm]	2-5/16, 5.9	2-5/16, 5.9	2-5/16, 5.9
Width [in, cm]	7-1/8, 18	7-1/8, 18	7-1/8, 18
Remote Level	No	No	Yes
Specifications common to all models:			
Frequency Response ± 1dB	10Hz-20kHz		
Signal-to-noise Ratio	>95dB, A-weighted, re: rated power		
Input Sensitivity	Low: 125mV-5V, High: 250mV-10V		
Electronic Crossover	150.2 & 300.4: Off, Variable HP & LP 50–200Hz, 12dB/octave slope 450.6: Amps 1 & 2 - Variable HP 0–200Hz, 12dB/octave slope; Amp 3 - Off, Variable HP & LP 50–200Hz, 12dB/octave slope		
KickEQ™ Bass Boost	0-12dB @ 40Hz (450.6 AMP 3)		

INSTALLATION

Mounting: Choose a dry, structurally sound location to mount your KICKER amplifier. Make sure there are no items behind the area where the screws will be driven. Choose a location that allows at least 4" (10cm) of open ventilation for the amplifier. Drill four holes using a 7/64" (3mm) bit and use the supplied #8 screws to mount the amplifier.

Wiring: The KMA amplifier's RCA inputs will receive either high or low level signals from your car stereo's source unit. A high-level signal can be run from the source unit's speaker outputs to the stereo RCA input on the end panel of the amplifier using the KICKER KISL as shown (see page 3). Alternatively, the signal can be delivered to the amplifier using the low-level RCA outputs on the source unit. Keep the audio signal cable away from factory wiring harnesses and other power wiring. If you need to cross this wiring, cross it at a 90 degree angle.

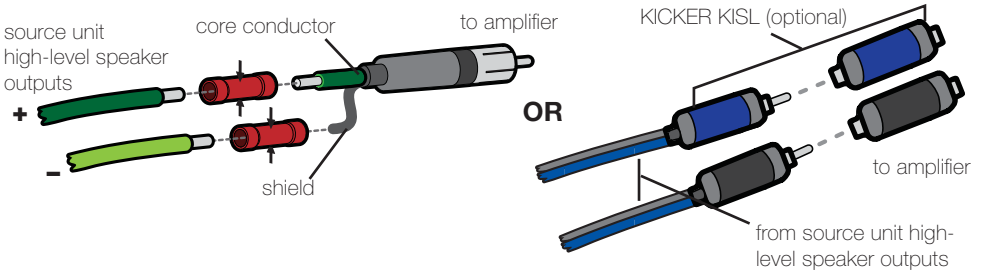

Install a fuse within 7" (18cm) of the battery and in-line with the power cable connected to your amplifier.

Model	External Fuse (sold separately)	Power/Ground Wire	KICKER Wiring Kit
KMA150.2	1 x 40 Ampere	8 Gauge	PK8, CK8
KMA300.4	1 x 60 Ampere	4 Gauge	PK4, CK4
KMA450.6	1 x 80 Ampere	4 Gauge	PK4, CK4

POWER WIRING

Amplifier uses 304-stainless steel screws and conformal coated PCB for increased weather resistance

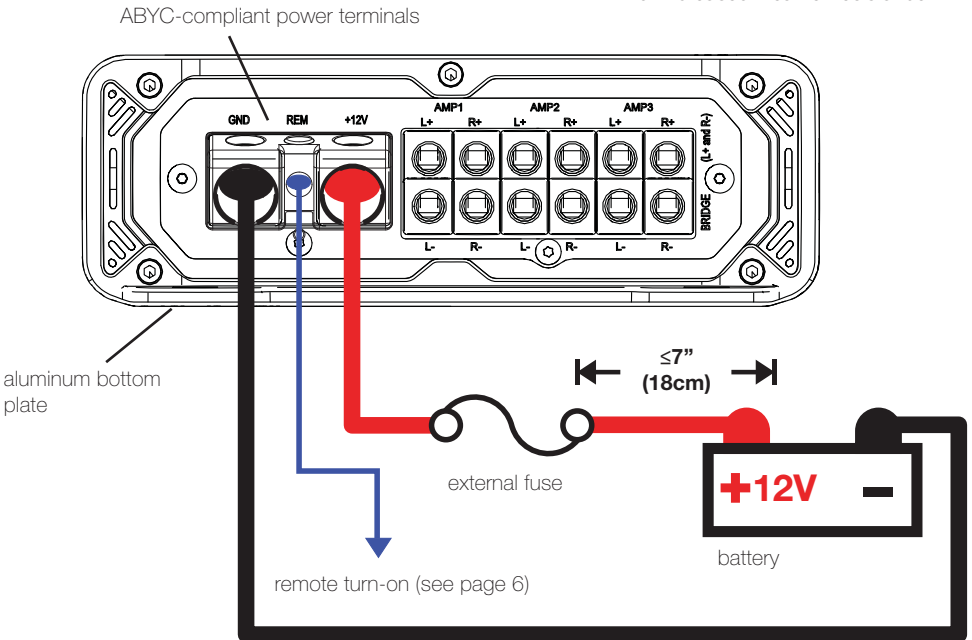

STEREO OPERATION
 minimum impedance of 2 ohm

(KMA450.6 shown)

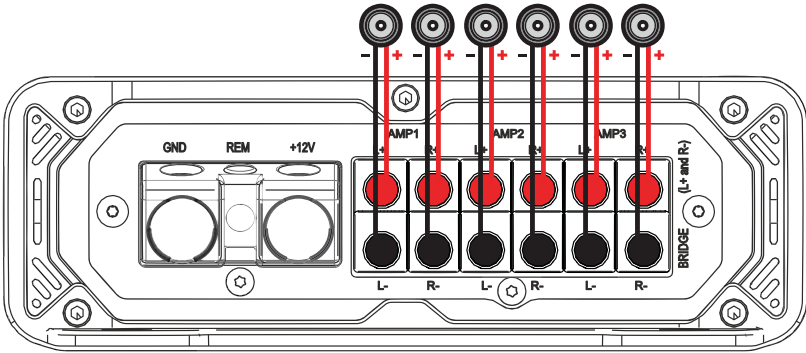

STEREO-AND-MONO-SIMULTANEOUSLY OPERATION
 minimum impedance of 4 ohms bridged (mono) and 2 ohm per channel stereo

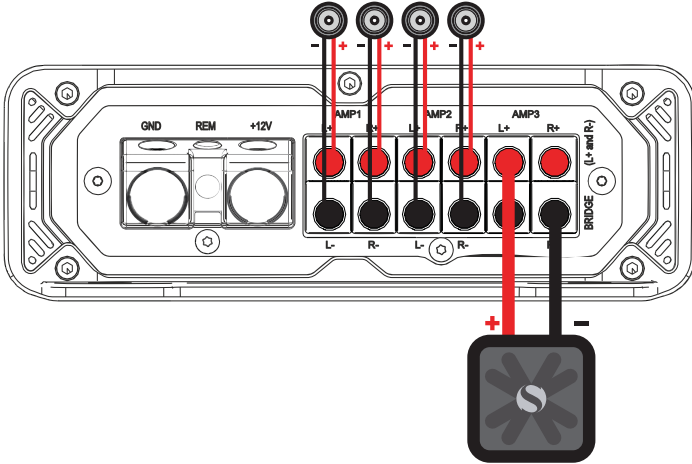

BRIDGED OPERATION (STEREO & MONO)
 minimum impedance of 4 ohms

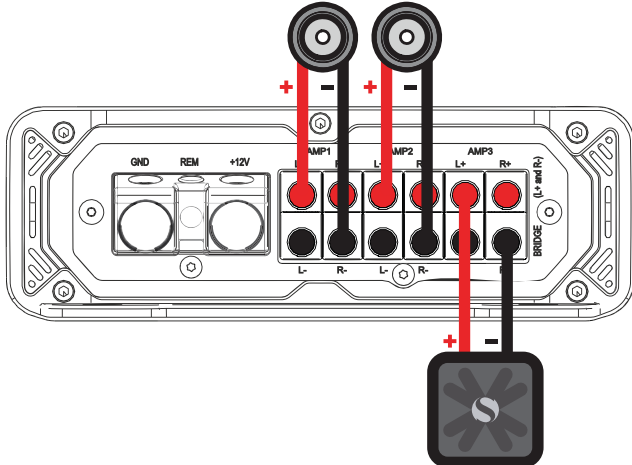

For multiple amplifier installations where distribution blocks are used, each amplifier should have its proper-rated fuse, or breaker, installed between the amplifier and the distribution block within seven inches of the block, or on the distribution block if it provides for fusing. The primary power wire should also be fused between the battery and distribution block, within seven inches of the battery's B+ terminal, with a fuse or breaker rated at least to the sum of the individual amplifier's fuse values, but not to exceed 1.5-times the sum of the individual fuse values (not to exceed the ampacity of the thermal insulation of the wiring as shown in U.S.C.G. CFR33 183.425, Table 5). See the diagram below.

NOTE: Seven inches is the standard distance under U.S. Coast Guard CFR33 for placement of fuses or breakers as required by law for new boat manufacturing. We recommend trying to adhere to this standard in a consumer installation. Failure to do so does not mean you are breaking the law, but it does put the safety of your boat and passengers at risk in the event of a power wire short circuit.

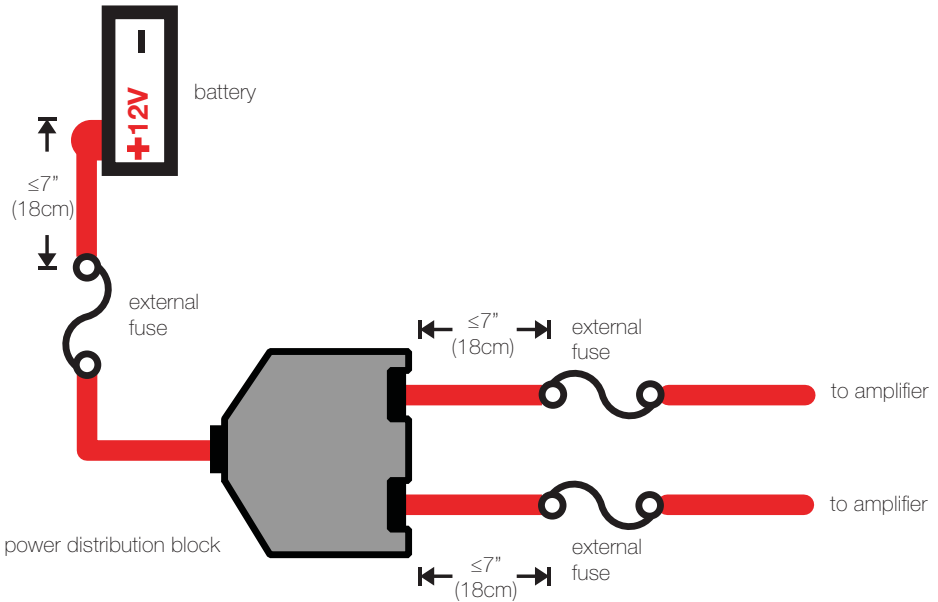

KICKER will now provide a three-year warranty with all KXA-Series Amplifier purchases paired with a qualifying KICKER Installation Kit* .

This extends the standard warranty by an additional year. *Amplifier and Kit must be purchased from an **Authorized KICKER Dealer**.*

KICKER KMA amplifier success is currently at an unheard-of rate, making the extended warranty program even more beneficial to you.

Using poor-quality, under-spec wiring kits will impede KMA amplifier performance.

A superior-quality KICKER installation Kit is guaranteed to extend the life of KMA amplifiers.

The new extended warranty applies only to KICKER amplifiers and accessories sold to consumers by Authorized KICKER Dealers in the United States of America or its possessions. It also only applies to the original purchaser of KICKER amplifiers and accessories. One warranty extension per amplifier is allowed regardless of the number of amplifier installation kits purchased. This program does not apply to "B"-stock product or factory-refurbished product.

This offer is for a limited time, so see your local Authorized KICKER Dealer soon for details.

***U.S.A. Only | EE.UU. solamente | Nur USA | Les USA Seulement**



OPERATION

REMOTE LEVEL not available with KMA150.2 and KMA300.4

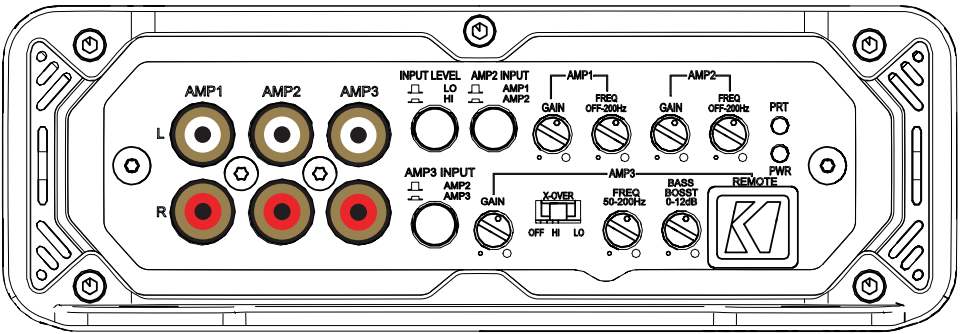

Automatic Turn-On Selection: The KMA series offers two different automatic turn-on modes that can be selected on the end panel; +12V and DC Offset. Using the DC Offset mode causes the REM wire to have +12V out for turning on additional amplifiers.

- Remote Turn-On: Set the switch to +12V to use the remote turn-on lead from your source unit. Run 18 gauge wire from the Remote Turn-On Lead on your source unit to the blue REM wire on KEY amplifier's wiring harness. This is the preferred automatic turn-on method.
- If 12V remote turn-on is not available, DC Offset turn-on can be used if speaker-level (high-level) audio inputs are being used. The DC offset mode detects a 6V DC offset on the speaker wires when the source unit has been turned on.

Input Level: The RCA inputs on KICKER KMA amplifiers are capable of receiving either Hi or Low-level signals from your source unit. If you are using a Hi-Level signal, simply press in the Input Level switch on the amplifier. Refer to the wiring section of this manual for additional instructions.

Crossover Control: The variable crossover on the side of the amplifier allows you to adjust the crossover frequency of AMP3 (*KMA450.6 only*) to OFF, hi-pass, or lo-pass from 50–200Hz, and the hi-pass crossover frequency of AMP1 & AMP2 from OFF-200Hz. OFF will pass a full-range signal, HI will cut off frequencies below a threshold, and LO will cut off frequencies above a threshold.

Input Gain Control: The input gain control is not a volume control. It matches the output of the source unit to the input level of the amplifier. Turn the source unit up to about 3/4 volume (if the source unit goes to 30, turn it to 25). Next, slowly turn (clockwise) the gain on the amplifier up until you can hear audible distortion, then turn it down a little.

Bass Boost Control: The variable bass boost control on the side of the amplifier is designed to give you increased output, 0–12dB, at 40Hz. The setting for this control is subjective. If you turn it up, you must readjust the input gain control to avoid clipping the amplifier.

Remote Level KMARC (KMA450.6): With the included KMARC remote level control, you have the ability to control the output level of the amplifier remotely. To surface-mount the KMARC remote level control, simply screw the remote to the chosen location, then run the cable from the controller to the "Remote" jack on the amplifier panel. See page 7 for installation.

KMARC REMOTE LEVEL INSTALLATION

KMA450.6 only

Surface-mount the KMARC remote using the supplied screws.

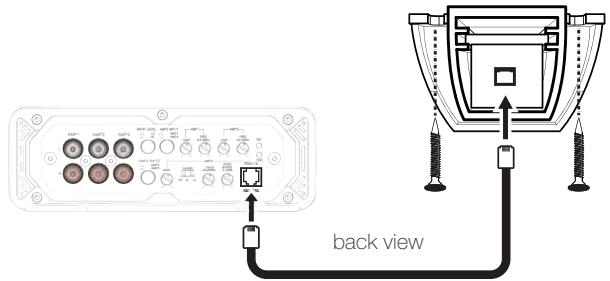
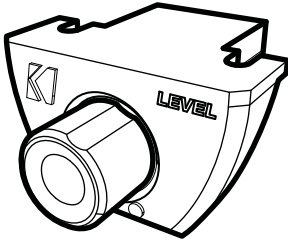

Remote cable passes audio; do not run cable parallel to power wires.

Connect the cable to the KMARC remote and the Remote connection on the amplifier

TROUBLESHOOTING

If your amplifier does not appear to be working, check the obvious things first such as blown fuses, poor or incorrect wiring connections, incorrect setting of crossover switch and gain controls, etc. There are Power (PWR) & Protection (PRT) LEDs on the side panel of your Kicker KMA series amplifier. Depending on the state of the amplifier and the vehicle's charging system, the LEDs will glow either green or red. When the green LED is lit, this indicates the amplifier is turned on and no trouble exists.

Green LED off, no output? With a Volt Ohm Meter (VOM) check the following: **1** +12 volt power terminal (should read +12V to +16V) **2** Remote turn-on terminal (should read +12V to +16V) **3** Check for reversed power and ground connections **4** Ground terminal, for proper conductivity.

Green LED on, no output? Check the following: **1** RCA connections **2** Test speaker outputs with a "known" good speaker. **3** Substitute source unit with a "known" good source unit. **4** Check for a signal in the RCA cable feeding the amplifier with the VOM meter set to measure "AC" voltage.

Red LED flickering with loud music? The red LED indicates low battery voltage. Check all the connections in your boat's charging system. It may be necessary to replace or charge your battery or replace your alternator.

Red LED on, no output? **1** Amplifier is very hot = thermal protection is engaged. Test for proper impedance at the speaker terminals with a VOM meter (see the diagrams in this manual for minimum recommended impedance and multiple speaker wiring suggestions). Also check for adequate airflow around the amplifier. **2** Amplifier shuts down only while your boat is running = voltage protection circuitry is engaged. Voltage to the amplifier is not within the 10–16 volt operating range. Have the boat's charging and electrical system inspected. **3** Amplifier will only play at low volume levels = short circuit protection is engaged. Check for speaker wires shorted to each other. Check for damaged speakers or speaker(s) operating below the minimum recommended impedance.

No or low output? ❶ Check the balance control on source unit ❷ Check the RCA (or speaker input) and speaker output connections. ❸ Check for reversed polarity at the speaker(s)

Alternator noise-whining sound with engine's RPM? ❶ Check for damaged RCA (or speaker input) cable ❷ Check the routing of RCA (or speaker input) cable ❸ Check the source unit for proper grounding ❹ Check the gain settings and turn them down if they are set too high.

Ground Noise? KICKER amplifiers are engineered to be fully compatible with all manufacturers' head units. Some head units may require additional grounding to prevent noise from entering the audio signal.

CAUTION: When jump starting the battery, be sure that connections made with jumper cables are correct. Improper connections can result in blown amplifier fuses as well as the failure of other critical systems in the boat.



KMA150.2

40 x 2 @ 4 ohms, 14.4VDC, 1% THD, CEA-2006B (Watts)
Signal to Noise Ratio -75dB CEA-2006B (ref: 1W, A-weighted)

KMA300.4

40 x 4 @ 4 ohms, 14.4VDC, 1% THD, CEA-2006B (Watts)
Signal to Noise Ratio -75dB CEA-2006B (ref: 1W, A-weighted)

KMA450.6

40 x 6 @ 4 ohms, 14.4VDC, 1% THD, CEA-2006B (Watts)
Signal to Noise Ratio -75dB CEA-2006B (ref: 1W, A-weighted)

