

**KICKER®**

---

**PXA** | *Amplifiers*

PXA 4-CHANNEL AMPLIFIER  
PXA300.4

Owner's Manual

**MODEL: PXA300.4**

IMPORTANT SAFETY WARNING – PROLONGED CONTINUOUS OPERATION OF AN AMPLIFIER IN A DISTORTED OR CLIPPED MANNER CAN CAUSE YOUR AUDIO SYSTEM TO OVERHEAT, POSSIBLY CATCHING FIRE AND RESULTING IN SERIOUS DAMAGE TO YOUR COMPONENTS AND/OR VEHICLE.

### PERFORMANCE

<b>Model:</b>	<b>PXA300.4</b>
RMS Power [Watts]	
@ 14.4V, 4Ω stereo, ≤ 1% THD+N	50 x 4
@ 14.4V, 2Ω stereo, ≤ 1% THD+N	75 x 4
@ 14.4V, 4Ω mono, ≤ 1% THD+N	150 x 2
Length [in, cm]	7-13/16, 19.7
Height [in, cm]	1-5/8, 4
Width [in, cm]	2-9/16, 6.5
Frequency Response [Hz]	10 - 20k
Signal-to-Noise Ratio [dB]	95
Input Sensitivity	Low Level: 125mV-5V High Level: 250mV-10V
Electronic Crossover	Selectable HI or OFF; 60Hz, 80Hz or 120Hz; 24dB/octave slope

**Pro Tip:** To get the best performance from your new KICKER Amplifier and extend the warranty by 1 year, use genuine KICKER accessories and wiring.

### INSTALLATION

**Mounting:** Choose a structurally sound location to mount your KICKER amplifier. Make sure there are no items behind the area where the screws will be driven. Choose a location that allows at least 4" (10cm) of open ventilation for the amplifier. Drill four holes using a 7/64" (3mm) bit and use the supplied #8 screws to mount the amplifier.

**Wiring:** Disconnect the vehicle's battery to avoid an electrical short. Then, connect the PXA harness to the amplifier. A good ground connections is important. If this amplifier is mounted in the front fairing of a motorcycle, it will be best to extend the ground wire all the way to the battery.

The PXA amplifiers have the capability to receive almost any level of input signal. If a Hi-Level signal is coming from the speaker leads of the source unit, simply cut off the RCA jacks and connect it directly to the exposed wires. Set the Input Level switch to Hi. Set the Auto Turn-On to DC. If speaker leads are not available from your source unit, use an RCA stereo cable to connect directly to the RCA connectors of the PXA amplifier. Set the Input Level switch to Lo. Set the Auto Turn-On switch to +12V, and use the blue remote trigger wire to turn the amplifier on.

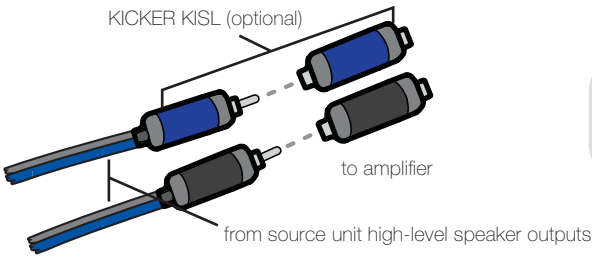

Model	External Fuse
PXA300.4	1 x 40 Ampere

Cut the looped red power cable located on the PXA harness and install a 40A fuse. Fuse installation should be within 18" (45cm) of the battery and in-line with the harness' power cable, which is connected to your amplifier. If you ever need to remove the amplifier from the vehicle after it has been installed, the ground wire should be the last wire disconnected from the amplifier—just the opposite as when you installed it. Use 8 gauge wire if the power wire is greater than 10 feet in length; 10 gauge if less.

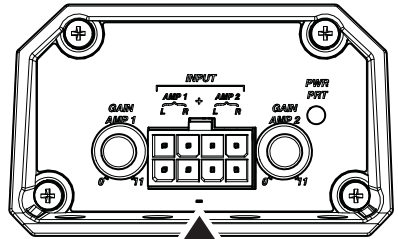
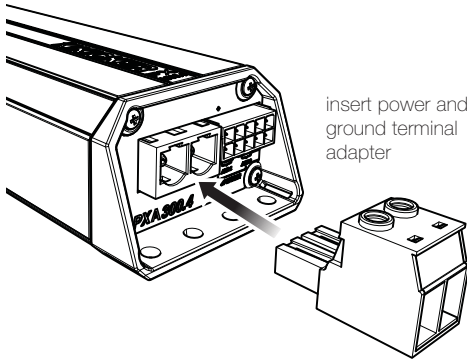

remote turn-on speaker outputs

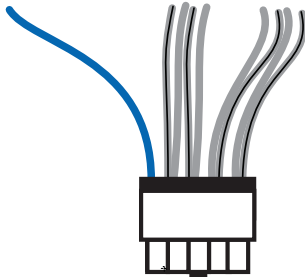

RCA inputs  
(remove to use hi-level input)

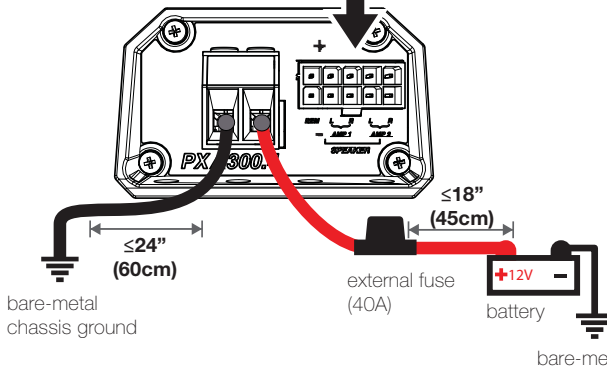

**BRIDGED OPERATION (MONO)**  
minimum impedance of 4 ohms

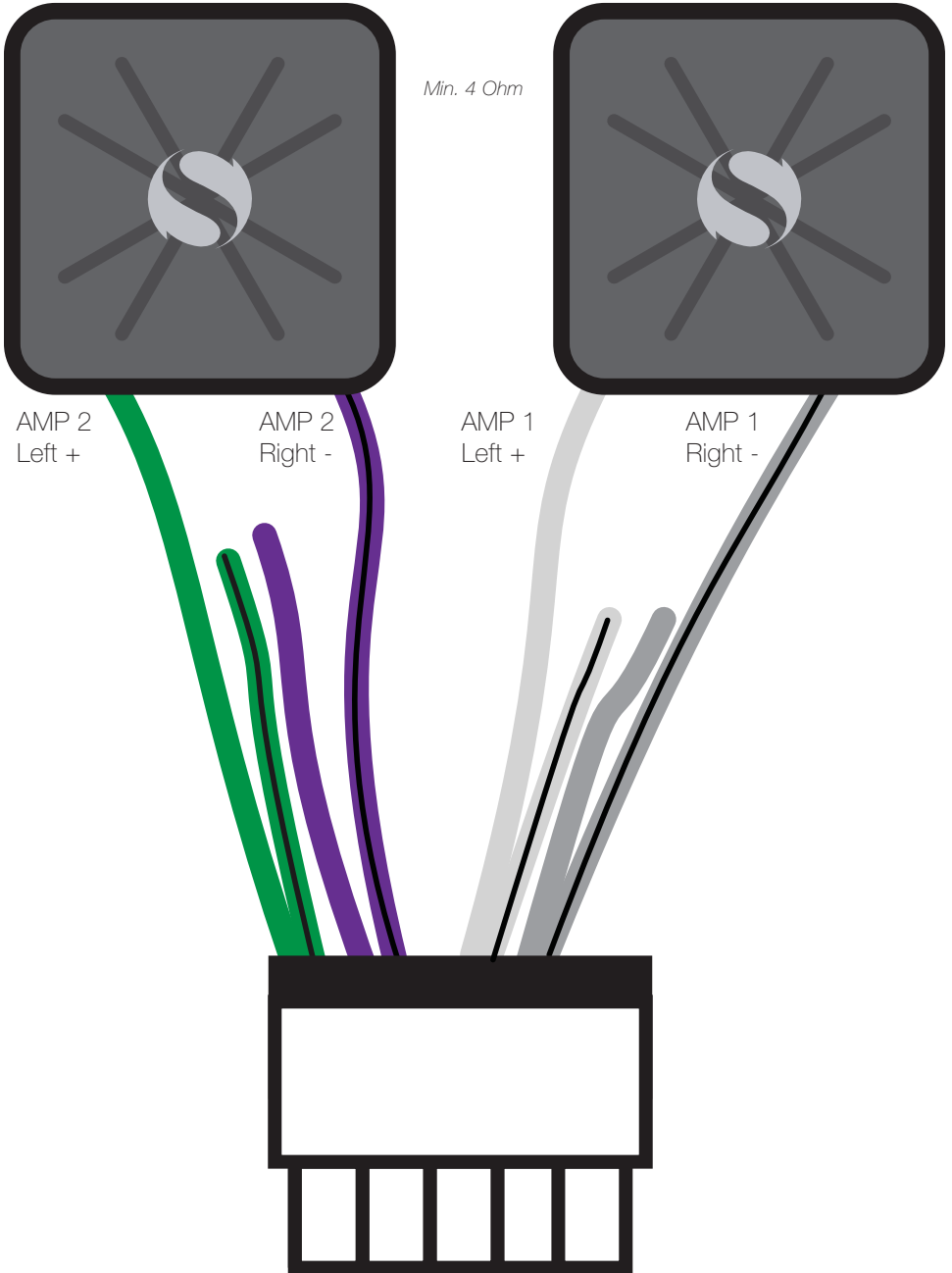

## OPERATION

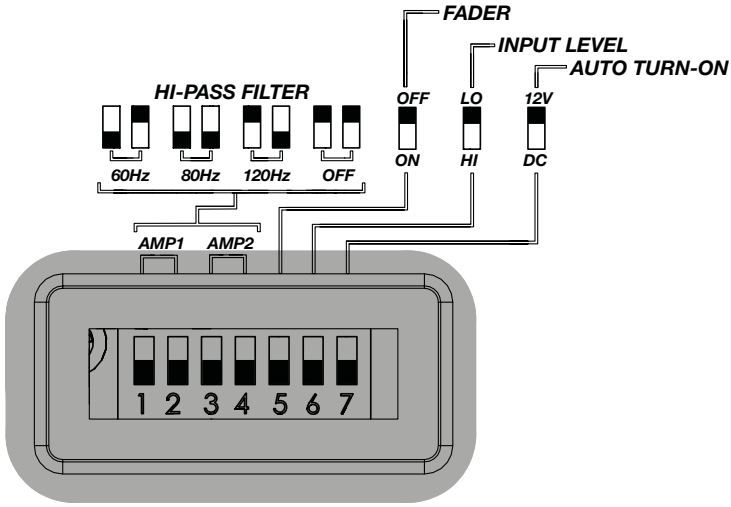

**Automatic Turn-On Selection:** The PXA series offers two automatic turn-on modes that can be selected on the end panel; +12V or DC Offset. Using the DC Offset mode causes the REM terminal wire to have +12V out for turning on additional amplifiers.

- Remote Turn-On: Set the switch to +12V to use the remote turn-on lead from the PXA harness. Run 18 gauge wire from the Remote Turn-On Lead on your source unit to the REM wire on the PXA harness. (Best for Lo-Level input)
- DC Offset Turn-On: The DC Offset mode detects a 6V DC offset from the HI-Level speaker outputs when the source unit has been turned on. (Best for Hi-Level input)

**Input Level:** The RCA inputs on KICKER PXA amplifiers are capable of receiving either Hi or Low-level signals from your source unit. When using a Hi-Level signal, simply set the Input Level switch on the amplifier to HI.

**Fader Switch:** Turn the fader switch ON if you are running two sets of inputs (front and rear for example) to the amplifier. Leave the fader switch OFF if you want to drive all channels from a single stereo input.

**HI-PASS Switches:** Use the HI-PASS switches behind the protective rubber covering of the amplifier to set the internal crossover. Choose a cutoff of 60Hz, 80Hz, 120Hz, or OFF depending on the configuration of switches. Never change the switches with the audio system on!

**Input Gain Control:** The input gain control is not a volume control. It matches the output of the source unit to the input level of the amplifier. Turn the source unit up to about 3/4 volume (if the source unit goes to 30, turn it to 25). Next, slowly turn (clockwise) the gain on the amplifier up until you can hear audible distortion, then turn it down a little.

## TROUBLESHOOTING

If your amplifier does not appear to be working, check the obvious things first such as blown fuses, poor or incorrect wiring connections, incorrect setting of crossover switch and gain controls, etc. There is a Power Protection LED on the side power panel of your Kicker PXA series amplifier. Depending on the state of the amplifier and the vehicle's charging system, the LED will glow either Red or Blue. When the blue LED is lit this indicates the amplifier is turned on and no trouble exists.

**Blue LED off, no output?** With a Volt Ohm Meter (VOM) check the following: **1** +12 volt power terminal (should read +12V to +16V) **2** Remote turn-on terminal (should read +12V to +16V) **3** Check for reversed power and ground connections **4** Ground terminal, for proper conductivity. **5** For Hi-Level input, check input wires for +6V.

**Blue LED on, no output?** Check the following: **1** RCA connections **2** Test speaker outputs with a "known" good speaker. **3** Substitute source unit with a "known" good source unit. **4** Check for a signal in the RCA cable feeding the amplifier with the VOM meter set to measure "AC" voltage.

**Protection LED flashing with loud music?** The red LED indicates low battery voltage. Check all the connections in your vehicle's charging system. It may be necessary to replace or charge your vehicle's battery or replace your vehicle's alternator.

**Protection LED on, no output?** **1** Amplifier is very hot = thermal protection is engaged. Test for proper impedance at the speaker terminals with a VOM meter (see the diagrams in this manual for minimum recommended impedance and multiple speaker wiring suggestions). Also check for adequate airflow around the amplifier. **2** Amplifier shuts down only while vehicle is running = voltage protection circuitry is engaged. Voltage to the amplifier is not within the 10–16 volt operating range. Have the vehicle's charging and electrical system inspected. **3** Amplifier will only play at low volume levels = short circuit protection is engaged. Check for speaker wires shorted to each other or to the vehicle chassis. Check for damaged speakers or speaker(s) operating below the minimum recommended impedance.

**No or low output?** **1** Check the balance control on source unit **2** Check the RCA (or speaker input) and speaker output connections.

**Alternator noise-whining sound with engine's RPM?** **1** Check for damaged RCA (or speaker input) cable **2** Check the routing of RCA (or speaker input) cable **3** Check the source unit for proper grounding **4** Check the gain settings and turn them down if they are set too high.

**Reduced bass response?** Reverse a speaker connection from positive to negative on the stereo/subwoofer channel(s); if the bass improves, the speaker was out of phase.

**Ground Noise?** KICKER amplifiers are engineered to be fully compatible with all manufacturers' head units. Some head units may require additional grounding to prevent noise from entering the audio signal. If you are experiencing this problem with your head unit, in most cases running a ground wire from the RCA outputs on the head unit to the chassis will remedy this issue.

**CAUTION:** When jump starting the vehicle, be sure that connections made with jumper cables are correct. Improper connections can result in blown amplifier fuses as well as the failure of other critical systems in the vehicle.

