



Polaris RANGER

“800 Syle Mount”

Part #: 101330
 Hardware Kit: HK-056, HK-031

Kit Components:

Qty	Part Description
1	Winch Mount
1	Fairlead Bracket
1	Fairlead Converter Bracket
6	3/8" x 1" HF Bolt
6	3/8" SAE Flat Washers
8	3/8" Nylock Nuts
2	5/16 x 1" Hex Head Flange Bolts
2	5/16" SAE Flat Washers
2	5/16" Nylock Nuts
2	3/8" x 1-1/4" SN Carriage Bolt
1	Spade Insulated terminal
1	Hardware Kit (Mini-Rocker Switch)

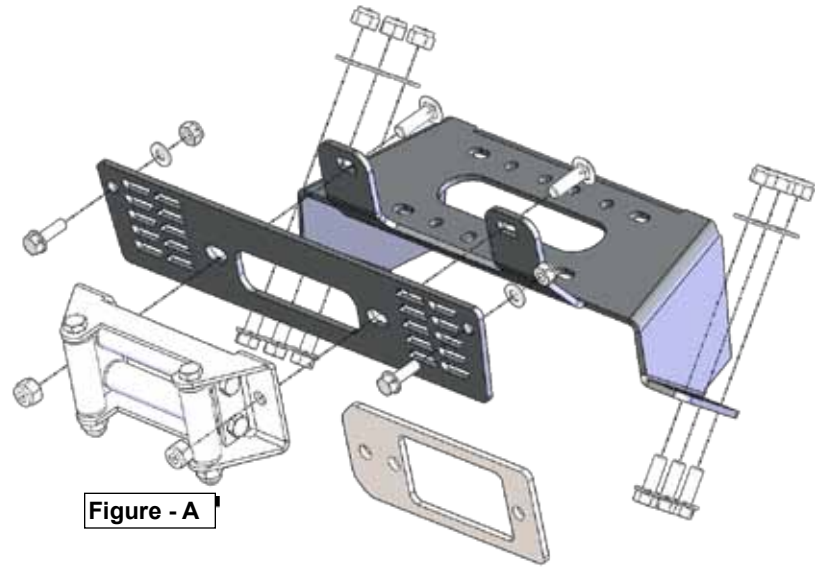

Figure - A

INSTALLATION INSTRUCTIONS:

PREPARE MACHINE

- Begin by turning the vehicle off and disconnecting the battery cables. Locate the battery compartment, usually under the hood, or on the current models under the drivers seat. Also on the crew it is under the rear driver-side seat. *Note: First remove the ground, then positive terminal.*

CONTACTOR

- Find the location on the passenger side under the hood compartment. (**Figure 1**) for full size Rangers and (**Figure 2**) for mid size Rangers. Fasten contactor using (4X) Screws included with winch kit. *Note: This location is set up for a standard contactor and some may not work with this bolt pattern but can be mounted in the general area.*

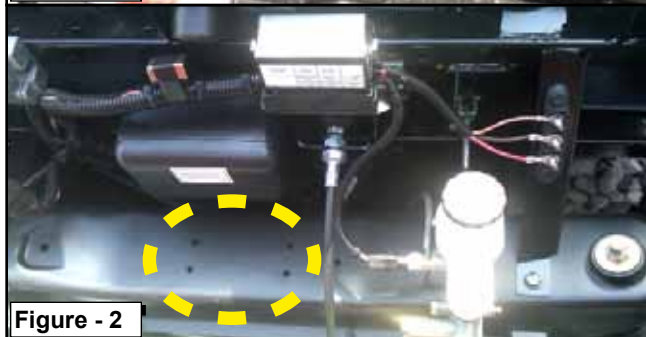

SWITCH

- Use included Mini-Rocker Switch Hardware Kit (HK-031) to fasten a handle bar mounted mini-rocker switch to the dash or any desired location.
 - Remove handlebar mount hardware from the switch
 - Locate desired mounting location
 - Mark & drill 2 switch holes thru dash using switch housing as a template
 - Drill a 3rd hole for switch wiring
 - Assemble per **Figure 3**

Figure - 3

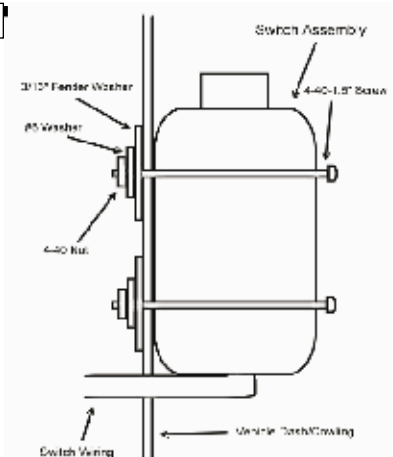

Optional Switch Mount Instructions*

REMOVE BUMPER

- Begin by removing the 4 Torx screws at locations **(A)** & **(B)** from the front and upper grills on the bumper frame as shown in **Figure 4**. Retain the upper grill **(A)**. Discard or set aside the front grill **(B)**. Then remove the three bolts **(C)** at the bottom of the frame (see **Figure 4**).

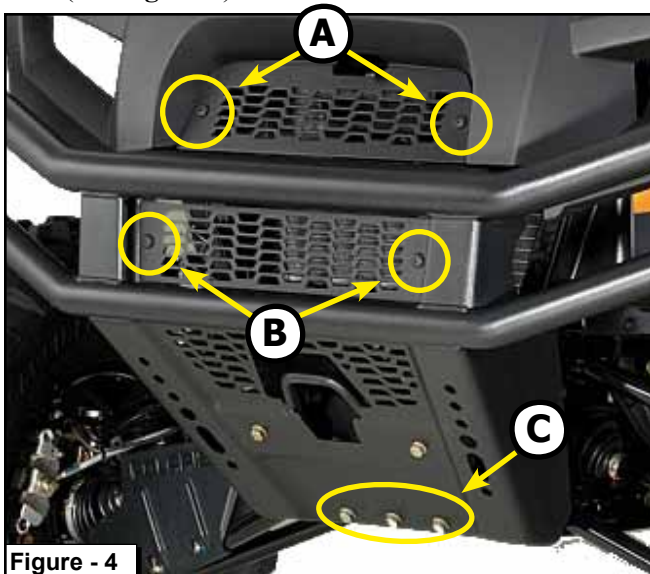

Figure - 4

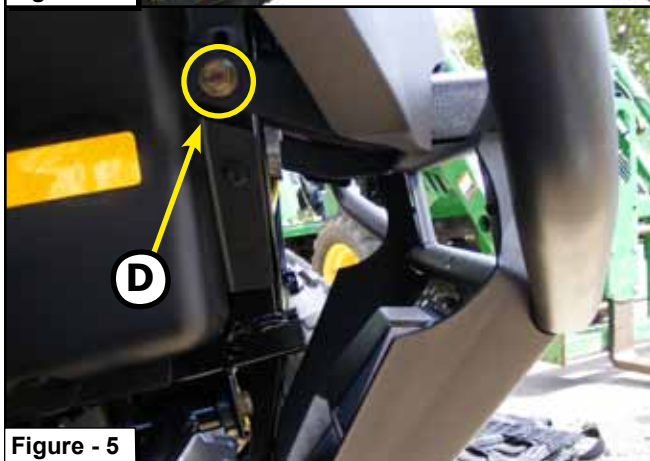
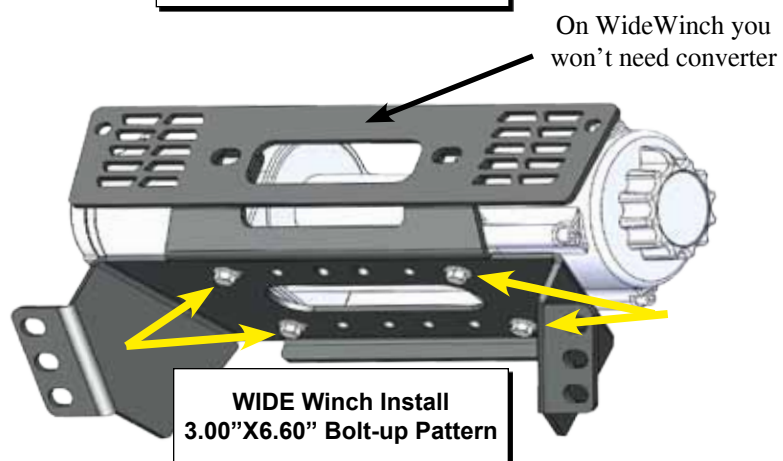
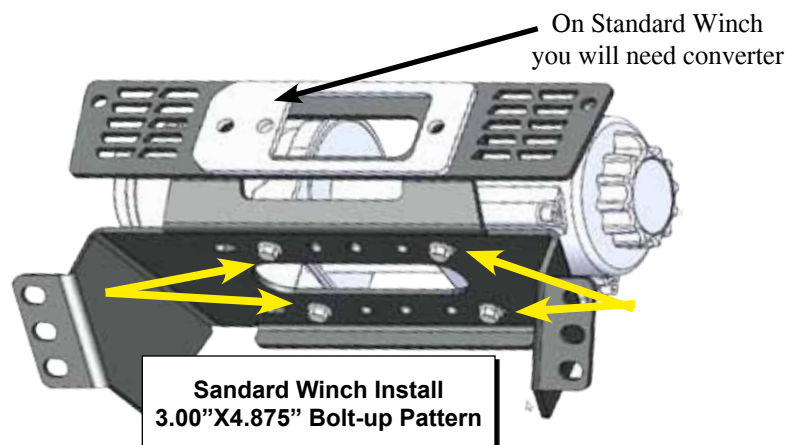
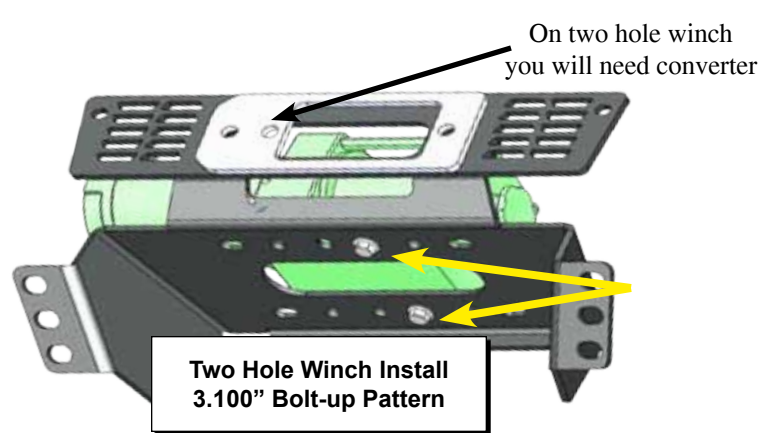

Figure - 5

- Remove 2 bolts **(D)** from the driver & passenger side of the bumper as shown in **Figure 5**. On some models there are two plastic clips you need to remove from the bumper. Finally remove the entire bumper from the machine.

ASSEMBLE WINCH TO MOUNT

- Assemble your winch to the mount plate using the hardware supplied with your winch.
- Depending on your winch there are three different bolt pattern's you will use; refer to the three patterns in the following images. If you have a two hole, or a standard winch you will need the converter plate.
- Connect the shorter winch wires to the winch leads. (usually Black and Red) Refer to Pg. 4 (Alternate Wiring Diagram)



ASSEMBLE WINCH MOUNT TO BUMPER

- Place the winch and mount assembly into location on the bumper and attach using the supplied 3/8" hardware as shown in **(Figure 6)**. Do not tighten. (winch not shown in picture)
- Place the new steel replacement grill and converter plate if needed while feeding your winch cable through the fairlead opening into its location as shown above.
- Assemble your roller fairlead by running the supplied carriage bolts through the mount, replacement grill and then the fairlead. If installing 2-HOLE or a STANDARD winch you will use one set of bolts supplied with your winch kit for the roller.

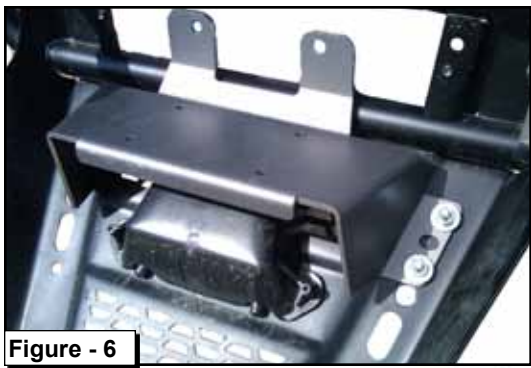

Figure - 6

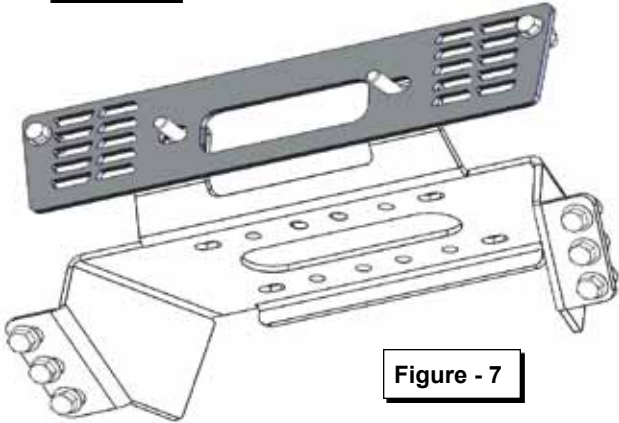

Figure - 7

14. Tighten everything down evenly.
15. Reinstall bumper to your machine.
15. Replace your upper grill removed in step 4 (A)

WIRING INSTRUCTIONS

16. Locate the wire terminal block under your hood. **(Figure 8)** Wire the red ignition wires for a mini-rocker switch or the controller to the terminal with the Orange and White wires shown in **(Figure 8)** using the supplied 22-18GA Spade Insulated Terminal.
17. If you have a RANGER CREW with the battery under the rear drivers side seat you will need the extended 11' cables included with our Extension Kit **(KFI#: UTV-WEK, sold separately).**

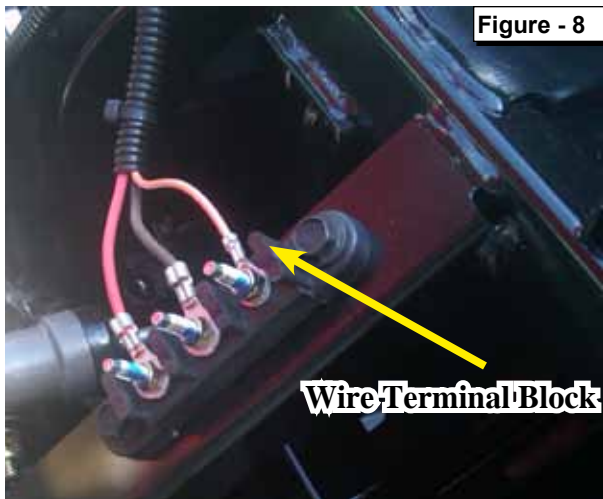

Figure - 8

Wire Terminal Block

18. Route the longest wires (usually BLUE & YELLOW) included with your winch from the solenoid or battery to the contactor location. Connect wires to contactor according to **ALTERNATE WINCH WIRING DIAGRAM** shown in **Figure 11**, - **NOT** according to the **color coding** in your winch manual or the contactor.
18. Connect winch, battery, and remaining switch wiring to your contactor using the alternate wiring diagram on Pg. 4
19. Secure all wires and reconnect battery positive & ground cable.

NOTE: If you do not have the standard battery Using the ALTERNATE WIRING DIAGRAM **(Figure 11, pg 4)** as a guide, attach the YELLOW POS(+) wire to the battery fed solenoid as shown in **Figure 9&10**. Then, attach the BLUE NEG(-) wire to the ground post as shown in **Figure 9&10**.

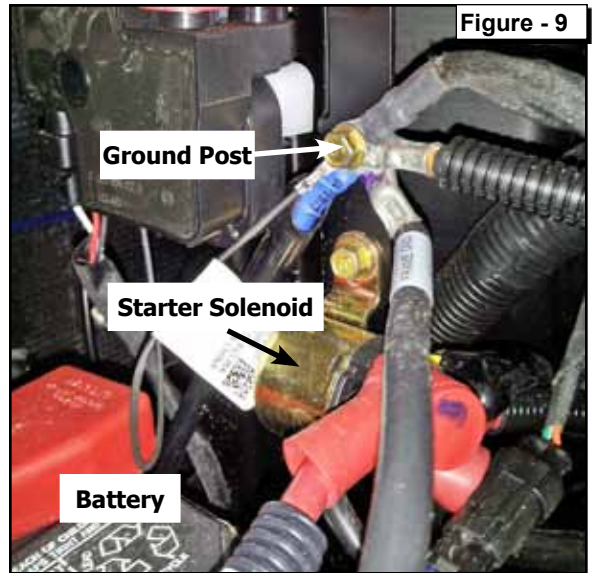

Figure - 9

Ground Post

Starter Solenoid

Battery

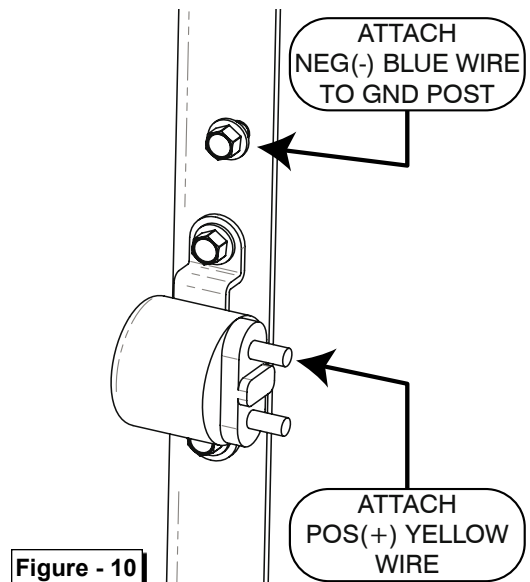
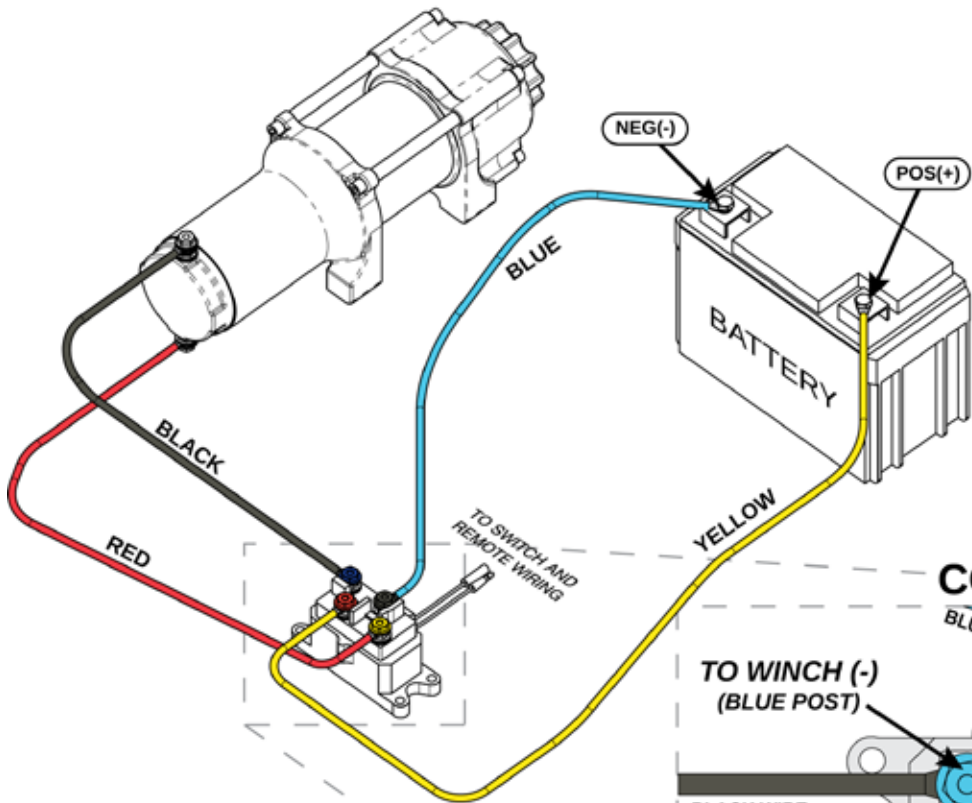

Figure - 10

Figure - 11

ALTERNATE WINCH WIRING DIAGRAM



* For use with ATV/UTV applications where contactor cannot be located close to vehicle battery.

* Run shortest wires, usually red & black from contactor to winch; run longest wires, usually blue & yellow from contactor to battery.

CAUTION
These two posts must be wired to the battery!

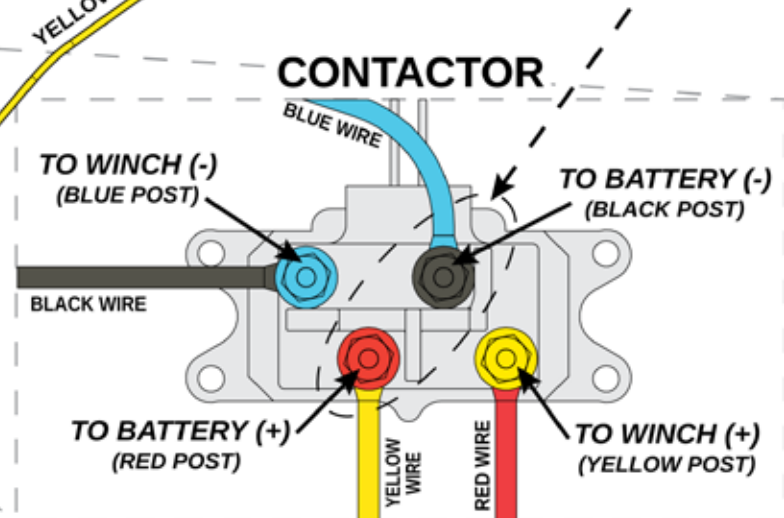

CAUTION
FAILURE TO FOLLOW WIRING DIRECTIONS AS SHOWN MAY RESULT IN DAMAGE TO YOUR WIRING SYSTEM OR EQUIPMENT.

- WIRE WINCH NEGATIVE (BLACK WIRE) TO --> BLUE CONTACTOR POST
- WIRE WINCH POSITIVE (RED WIRE) TO --> YELLOW CONTACTOR POST
- WIRE BATTERY NEGATIVE (BLUE WIRE) TO --> BLACK CONTACTOR POST
- WIRE BATTERY POSITIVE (YELLOW WIRE) TO --> RED CONTACTOR POST



** = Requires the purchase of #UTV-WEK (wire extension kit) Due to location of battery on Ranger.

