



INSTALLATION INSTRUCTIONS

PART No. 30459

MODEL No.

STAINLESS STEEL WINDSHIELD WIPER MOTOR COVER

- A. Fasten Back Up Plate To Windshield Frame Using 5/32" & 1/8" Pop Rivets
- B. Mount and Fasten Wiper Motor Cover Using 1/4"-20 X 1/2" Long Hex Bolts
- C. Fasten Wiper Motor Cover Using #10-24 X 3/8" Long Bolts (3-Required)
- C* Some Windshield Frames Have a Smaller Tapped Hole, Use 4 X .75 X 10MM Hex Bolt In Place of the # 10 Hex Bolt

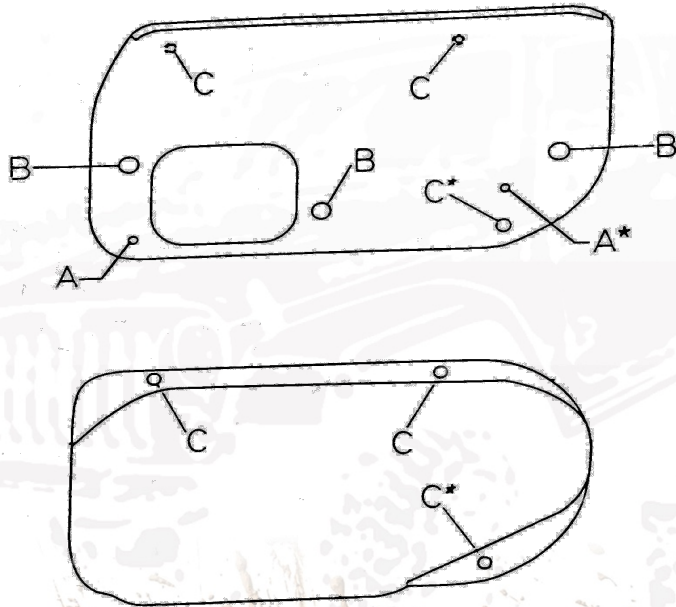

INSTALLATION INSTRUCTIONS

PART No. 30459

MODEL No.

STAINLESS STEEL WINDSHIELD WIPER MOTOR COVER

- A. Fasten Back Up Plate To Windshield Frame Using 5/32" & 1/8" Pop Rivets
- B. Mount and Fasten Wiper Motor Cover Using 1/4"-20 X 1/2" Long Hex Bolts
- C. Fasten Wiper Motor Cover Using #10-24 X 3/8" Long Bolts (3-Required)
- C* Some Windshield Frames Have a Smaller Tapped Hole, Use 4 X .75 X 10MM Hex Bolt In Place of the # 10 Hex Bolt

