



WHEREVER TIRES ARE CHANGED™

**Manual Tire
Changing Systems**

OWNERS MANUAL

**MODEL #T600 (38600) CENTER POST TIRE CHANGING SYSTEM-BENCH
MOUNT/RIM CLAMP ADAPTER**

For use on tires size 4" to 12"

**MODEL #T601 (38601) CENTER POST TIRE CHANGING SYSTEM- FLOOR
MODEL**

For use on tires size 4" to 15"

CAUTION: Read Rules for Safe Operation and Instructions Carefully.

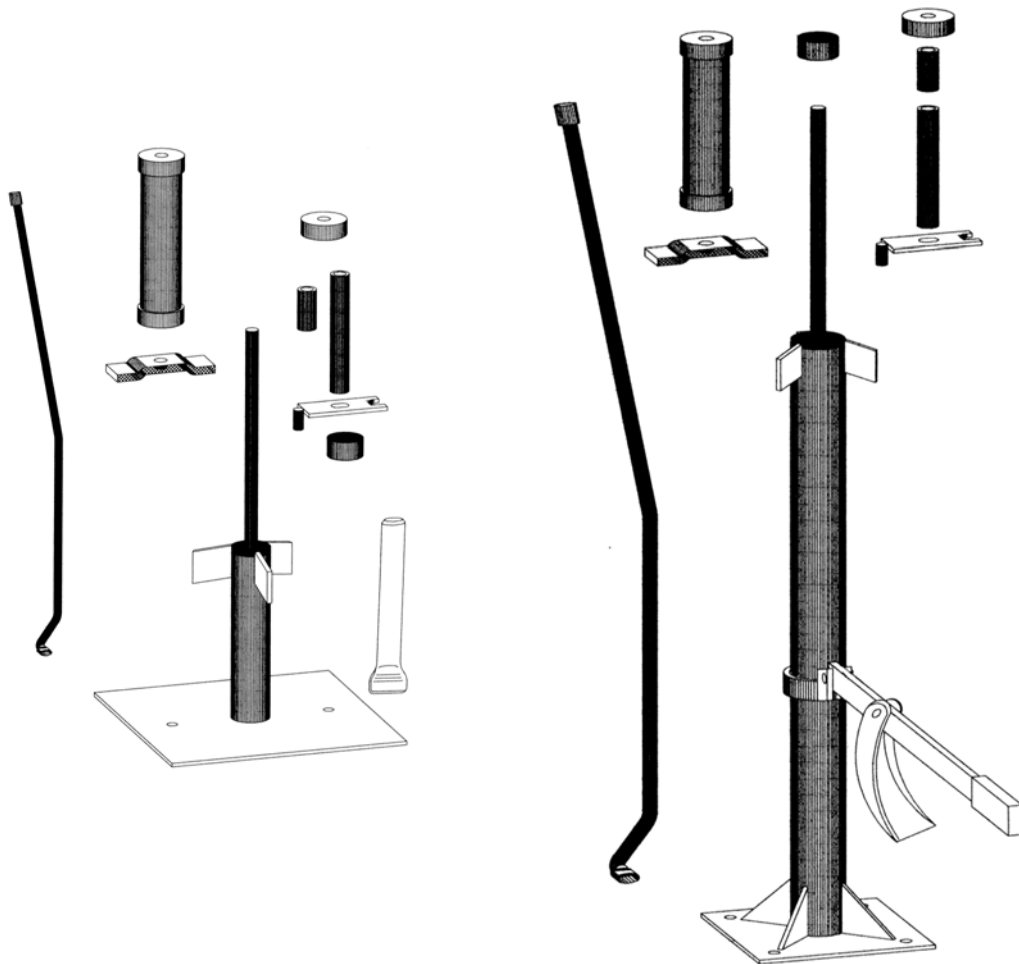

Manual Tire Changing Systems

Bench Mount Model #T600 (38600) Floor Model #T601 (38601)

Table of Contents

Safety Precautions	Page 3
Parts List	Page 4
Parts Illustration	Page 4
Assembly Instructions	Page 5
Instructions for Operation:	
Section 1a) Breaking the Bead Using the Bench Mount Model	Page 6
Section 1b) Breaking the Bead Using the Floor Mount Model	Page 6
Section 2) Demounting the Tire from the Rim	Page 7
Section 3) Mounting the Tire to the Rim	Page 11
Maintenance and Care	Page 15

IMPORTANT SAFETY PRECAUTIONS FOR CHANGING SMALL AND MEDIUM SIZE TIRES

READ ENTIRE SAFETY PRECAUTIONS AND INSTRUCTION MANUAL BEFORE YOU CHANGE TIRES WITH THIS UNIT.

WARNING: If you don't know how to use tire-changing tools – STOP! Tire changing should only be done by trained persons. Improper tire changing can result in injury or death.

Here are some safety rules to follow for using this tire machine, tire tools and equipment:

1. Always wear approved safety eye protection when servicing tires and wheels and whenever using hand tools.
2. Follow all tire and rim manufacturers' instructions when changing and inflating tires. Ensure that tire and rim sizes match. Mismatched components can cause serious injury during inflation.
3. While inflating tire, use clip-on chuck with sufficient length of hose, and hand-held pressure valve to inflate tires. Do not use flammable materials when mounting or demounting tires. Keep clear of trajectory zone.
4. Never use a tire tool for anything except mounting or demounting tires.
5. Use the right tool. Don't force a small tool or attachment to do the work of a larger industrial tool. Don't use a tool for a purpose for which it was not intended.
6. Check for damaged or broken parts. Check for other conditions that may affect its operation. Do not use damaged parts. Any part that is damaged should be replaced. If replacement parts are needed, use only identical replacement parts. Only use accessories intended for use with this tool. Approved replacement parts and accessories are available from Ken-Tool. Check mounting bolts for proper tightness prior to each use.
7. Completely deflate tire before attempting to break the bead or demount the tire from rim. This requires removing the valve core and probing the valve with a wire to remove any obstructions which may prevent air from escaping.
8. Keep work area clean. Cluttered areas invite injuries.
9. Don't overreach. Keep proper footing and balance at all times.
10. Always return bead breaker to highest position with arm retracted when not in use, to prevent possible injury.

Parts List/Illustration

Bench Mount Model #38600

- 1) One (1) Main Body
- 2) One (1) Hand Held Bead Breaker
- 3) One (1) Bearing Guide
- 4) One (1) Lug-Type Wheel Hold-Down Plate
- 5) One (1) 6" Sleeve
- 6) One (1) 3" Sleeve
- 7) One (1) Round Nut
- 8) One (1) Tire Snake™ #34672
- 9) One (1) ATV Hold-Down Plate and Pin
- 10) One (1) Shaft Support Barrel
- 11) One (1) Instruction Manual

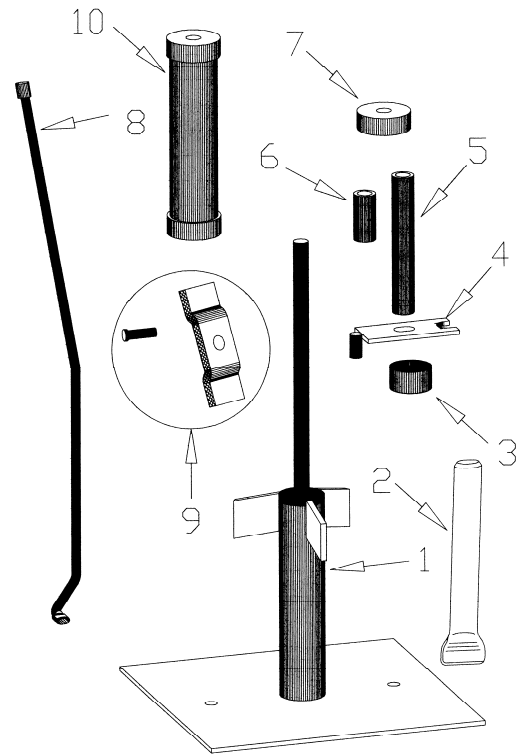

Floor Model #38601

- 1) One (1) Main Body
- 2) One (1) Parts Bag Which Includes:
Instruction Manual
Three (3) 3/8" X 1 1/2" Clevis Pins (9E)
Two (2) 3/8" Washers (9F)
Two (2) Cotter Pins (9G)
- 3) One (1) Shaft Support Barrel
- 4) One (1) Bearing Guide
- 5) One (1) Lug-Type Wheel Hold-Down Plate
- 6) One (1) 6" Sleeve
- 7) One (1) 3" Sleeve
- 8) One (1) Round Nut
- 9) One (1) Bead Breaker Assembly
Foot (9A)
Handle (9B)
Handle Grip (9C)
Ring (9D)
- 10) One (1) ATV Hold-down Plate and Pin
- 11) One (1) Tire Snake™ #34674

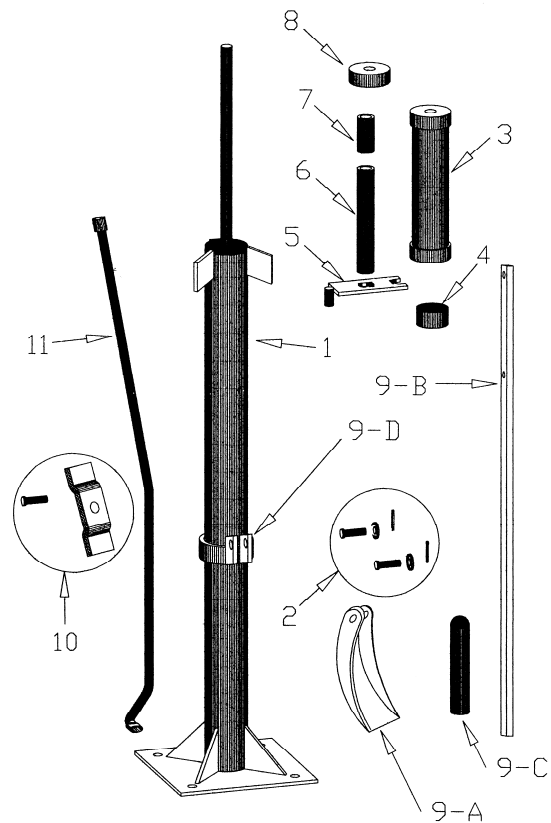

ASSEMBLY INSTRUCTIONS

Center Post Tire Changing System Bench Mount Model #38600

1. Remove and locate all parts from the box using the parts list. If you are missing a component, please contact Ken-Tool customer service at 330/535-7177.
2. Secure unit to a suitable work surface. Utilize holes in base to bolt down using bolts no smaller than 1/2", or clamp in a rim-clamp tire machine. Do not use wood screws.
3. Extend the threaded mounting shaft to full height by turning counter-clockwise. Lubricate with any general purpose oil.

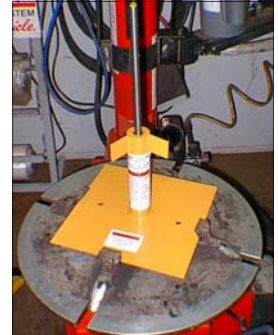

#38600 shown
secured to rim clamp
machine.

Center Post Tire Changing System Floor Mount Model #38601

1. Remove and locate all parts from the box using the parts list. If you are missing a component, please contact Ken-Tool customer service at 330/535-7177.
2. For concrete or tile floors: Locate the best work area and permanently mount your machine to the floor using concrete inserts and bolts no smaller than 1/2". (Concrete inserts and bolts are not included and can be purchased locally.) **Optional mounting procedure for portability:** (or for use on wooden, dirt or other soft floors) It is recommended you mount your machine to any suitable steel or wooden surface having a minimum surface area of 4 ft. X 4 ft.
3. Position bead breaker handle in bead breaker ring and insert clevis pin. Place 3/8" washer over clevis pin and insert cotter pin.
4. Position bead breaker shoe on handle and insert clevis pin, washer, and cotter pin (see drawing on Instruction Manual cover).
5. Place rubber grip for bead breaker onto handle end.
6. Extend threaded mounting shaft to full height by turning counter-clockwise. Lubricate with any general purpose oil.

Instructions for Use

Section 1) To break the bead from the rim on all wheel and tire sizes

Before you start: Read all safety precautions.
Use tire lubricant whenever mounting or demounting tires.
Totally deflate the tire before attempting to break the bead.
Remove the valve core and probe for any obstacles which may prevent air from escaping.

Section 1a) Breaking the Bead using the Bench Mount Model #T600

1. To break the bead from the rim, lay the tire flat on the floor or other suitable work surface. (Do not break bead while tire is mounted to machine.) Position hand held bead breaker so foot of tool rests between rim and tire. Hit end of bead breaker with soft-faced hammer to force the bead from the rim. Do not strike metal to metal. Rotate the tire and repeat the procedure in several locations on the tire if the bead and wheel do not separate.
2. Turn tire over and break second bead. The tire must be free of the wheel in order to remove the tire.

Section 1b) Breaking the Bead using the Floor Mount Model #T601

1. To break the bead from the rim, lay the tire flat on the floor near the machine.
2. While holding the bead breaker handle in a raised position, adjust the height of the sliding bead breaker ring so that the shoe rests on the tire against the edge of the rim. Tire may have to be moved closer to or further from the machine for proper placement of the bead breaking shoe. The height of the bead breaker is instantly adjustable without disassembling and reassembling machine components.
3. Push down on handle, forcing the tire bead away from the rim. Rotate the tire and repeat the procedure in several locations on the tire if the bead and wheel do not separate.
4. Turn tire over and repeat to break bead from other side of rim. The tire must be free of the wheel in order to remove the tire.

Section 2) Demounting the Tire from the Rim using either the Bench Mount Model #T600 or the Floor Mount Model #T601 (unless noted).

A. 5/8" and larger straight axle wheels:

1. After the bead of the tire has been broken away from the wheel (see section 1), place the tire/rim assembly over the threaded mounting shaft with the valve stem facing up.
2. Install the bearing guide with angle side down (see diagram) to center wheel on threaded center post.
3. Place one or both spacer sleeves over post and secure with round nut. Hand tighten only. Caution: do not use machine without spacer sleeves. This will damage the threaded mounting shaft and make it unusable.
4. Once the tire is securely held in place, apply adequate amount of Bead-Eze® (or similar tire lubricant) to both sides of the tire bead and wheel. Do not use flammable materials when servicing tires and wheels.
5. Next, place the demount (straight) end of the Tire Snake™ in between the tire and the rim at a point closest to you, with the flat side of the demount end against the rim and the rounded side against the tire bead (photo A). Push the bar forward, lifting the bead over the rim until you hear the "click" of the Tire Snake as it positions correctly against the rim. The Tire Snake should be positioned so you can use the center post for support when pulling the bar (photo B).
6. Pull the bar toward you around the center post in a clockwise circular motion to demount the bead (photo C).
7. After the first bead has been demounted, pull the tire up toward the top bead, place the flat end of the demounting tool between the second bead of the tire and the rim as before and repeat the removal process.

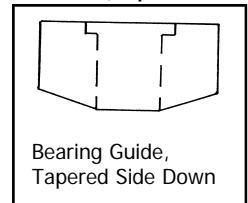

Photo A: Demount

B.



Photo B: Demount



Photo C: Demount

5/8" and 3/4" bearing wheel types:

1. After the bead of the tire has been broken away from the wheel (see section 1), place the tire/rim assembly over the threaded mounting shaft with the valve stem facing up.
2. Install the bearing guide with recess side down to prevent bearing damage (see diagram).
3. Place one or both spacer sleeves over post and secure with round nut. Hand tighten only. Caution: Do not use machine without spacer sleeves. This will damage the threaded mounting shaft and make it unusable.
4. Once the tire is securely held in place, apply adequate amount of Bead-Eze® (or similar tire lubricant) to the tire bead. Do not use flammable materials when servicing tires and wheels.
5. Next, place the demount (straight) end of the Tire Snake™ in between the tire and the rim at a point closest to you, with the flat side of the demount end against the rim and the rounded side against the tire bead (photo A). Push the bar forward, lifting the bead over the rim until you hear the "click" of the Tire Snake as it positions correctly against the rim. The Tire Snake should be positioned so you can use the center post for support when pulling the bar (photo B).
6. Pull the bar toward you around the center post in a clockwise circular motion to demount the bead (photo C).
7. After the first bead has been demounted, pull the tire up toward the top bead, place the flat end of the demounting tool between the second bead of the tire and the rim as before and repeat the removal process.

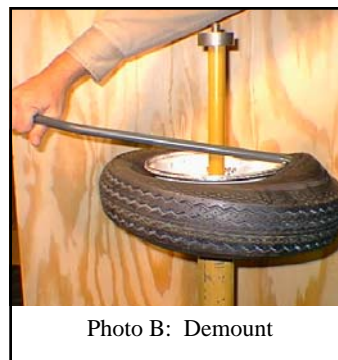
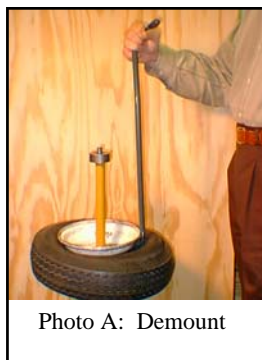
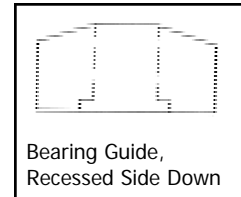

C. Four-lug and Five-lug wheel types (12" and smaller):

1. After the bead of the tire has been broken away from the wheel (see section 1), place the tire/rim assembly over the center post with the valve stem facing up. Approximately center the rim on the three fins.

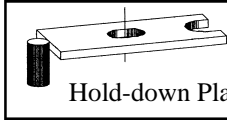
2. Install the hold-down plate with the pin facing down through any lug hole (see diagram). Turn the wheel clockwise until the pin of the hold-down plate contacts the nearest fin, centering the wheel. Place one or both spacer sleeves over post and secure with round nut. Hand tighten only. Caution: Do not use machine without spacer sleeves. This will damage the threaded mounting shaft and make it unusable.
- 
- The diagram shows a rectangular metal plate with a central hole and a smaller hole on the right side. A pin is inserted through the central hole, and a round nut is shown on the right side of the plate. The text 'Hold-down Plate' is written below the diagram.
3. Once the tire is securely held in place, apply adequate amount of Bead-Eze® (or similar tire lubricant) to tire bead. Do not use flammable materials when servicing tires and wheels.
 4. Next, place the demount (straight) end of the Tire Snake™ in between the tire and the rim at a point closest to you, with the flat side of the demount end against the rim and the rounded side against the tire bead (photo A). Push the bar forward, lifting the bead over the rim until you hear the “click” of the Tire Snake as it positions correctly against the rim. The Tire Snake should be positioned so you can use the center post for support when pulling the bar (photo B).
 5. Pull the bar toward you around the center post in a clockwise, circular motion to demount the bead (photo C).
 6. After the first bead has been demounted, pull the tire up toward the top bead, place the flat end of the demounting bar between the second bead of the tire and the rim as before and repeat the removal process.

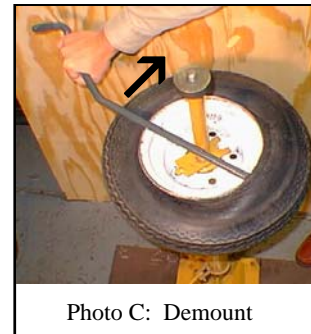
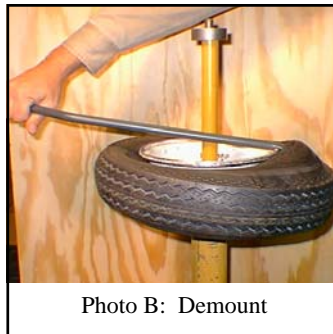

D. Four-lug and Five-lug wheel types for Passenger Car and Light Trucks:

1. After the bead of the tire has been broken away from the wheel (see section 1), place the tire/rim assembly over the center post with the valve stem facing up. Approximately center the rim on the three fins.
2. Install the hold-down plate with the pin facing down through any lug hole. Turn the wheel clockwise until the pin of the hold-down plate contacts the nearest fin, centering the wheel. Place the shaft support barrel over the threaded rod and secure with round nut. Hand tighten only. (see diagram).

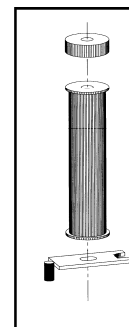

3. Once the tire is securely held in place, apply adequate amount of Bead-Eze® (or similar tire lubricant) to tire bead. Do not use flammable materials when servicing tires and wheels.
4. Next, place the demount (straight) end of the Tire Snake™ in between the tire and the rim at a point closest to you, with the flat side of the demount end against the rim and the rounded side against the tire bead (photo A). The optional large Tire Snake is recommended (available separately). Push the bar forward, lifting the bead over the rim until you hear the “click” of the Tire Snake as it positions correctly against the rim. The Tire Snake should be positioned so you can use the center post for support when pulling the bar (photo B).
5. Pull the bar toward you around the center post in a clockwise, circular motion to demount the bead (photo C).
6. After the first bead has been demounted, pull the tire up toward the top bead, place the flat end of the demounting bar between the second bead of the tire and the rim as before and repeat the removal process.

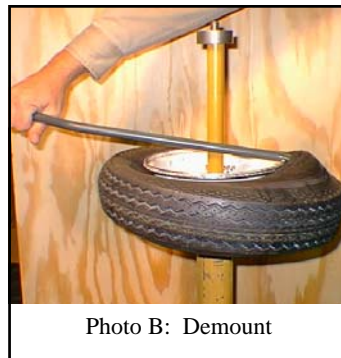

E. ATV Deep Dish Rims

1. After the bead of the tire has been broken away from the wheel (see section 1), place the tire/rim assembly over the center post with the valve stem facing up.
2. Place the 3/8" pin through any lug hole of the ATV wheel and turn the wheel clockwise until the pin contacts the nearest fin, centering the wheel on the machine. Install the ATV mounting plate. Place the shaft support barrel over the threaded rod and mounting plate and secure with round nut. Hand tighten only.
3. Once the tire is securely held in place, apply adequate amount of Bead-Eze® (or similar tire lubricant) to tire bead. Do not use flammable materials when servicing tires and wheels.
4. Next, place the demount (straight) end of the Tire Snake™ in between the tire and the rim at a point closest to you, with the flat side of the demount end against the rim and the rounded side against the tire bead (photo A, page 11). The optional large tire snake is recommended (available separately). Push the bar forward, lifting

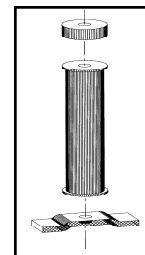

the bead over the rim until you hear the “click” of the Tire Snake™ as it positions correctly against the rim. The Tire Snake should be positioned so you can use the center post for support when pulling the bar (photo B).

5. Pull the bar toward you around the center post in a clockwise, circular motion to demount the bead (photo C).
6. After the first bead has been demounted, pull the tire up toward the top bead, place the flat end of the demounting bar between the second bead of the tire and the rim as before and repeat the removal process.



Photo A: Demount

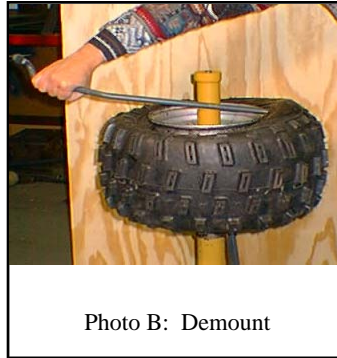

Photo B: Demount

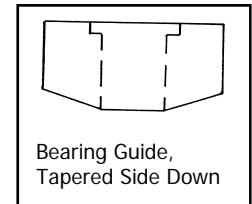

Photo C: Demount

Section 3) Mounting the Tire to the Rim

A. 5/8" and larger straight axle wheels:

1. Place the rim over the center post with the valve stem facing up.
2. Install the bearing guide with angle side down (see diagram) to center wheel on threaded center post. Place one or both spacer sleeves over post and secure with round nut. Hand tighten only. Caution: do not use machine without spacer sleeves. This will damage the threaded mounting shaft and make it unusable.
3. Once the rim is securely held, apply adequate amount of Bead-Eze® (or similar tire lubricant) to tire bead. Do not use flammable materials when servicing tires and wheels. Place tire on rim.
4. Cock the tire on the rim and hook the mount (curved) end of the Tire Snake™ (see photo A, p. 12) over the exposed edge of the rim on side nearest you. Place your left hand flat against the sidewall of the tire to hold in place. Use caution when mounting to keep fingers from being pinched between rim and bead as tire is mounted to rim. Grasp the Tire Snake at its farthest end, keeping it parallel with the rim. Pull the bar in a clockwise direction around the center post until first bead is mounted (see photo B, p. 12).
5. To mount the second bead, follow the same procedures. Place your left hand flat against the sidewall of the tire, pushing down to keep bead below the drop-center (smallest diameter of the rim). See photo C, p. 12.



B. 5/8" and 3/4" bearing wheel types:

1. Place the rim over the center post with the valve stem facing up.
2. Install the bearing guide with recess side down to prevent bearing damage (see diagram). This centers the wheel on the threaded center post. Place one or both spacer sleeves over post and secure with round nut. Hand tighten only. Caution: Do not use machine without spacer sleeves. This will damage the threaded mounting shaft and make it unusable.
3. Once the rim is securely held in place, apply adequate amount of Bead-Eze® (or similar tire lubricant) to the tire bead. Do not use flammable materials when servicing tires and wheels. Place tire on rim.
4. Cock the tire on the rim and hook the mount (curved) end of the Tire Snake™ over the exposed edge of the rim on side nearest you. Place your left hand flat against the sidewall of the tire to hold in place. Use caution when mounting to keep fingers from being pinched between rim and bead as tire is mounted to rim. Grasp the Tire Snake™ at its farthest end, keeping it parallel with the rim. Pull the bar in a clockwise direction around the center post until first bead is mounted. See photos below.
5. To mount the second bead, follow the same procedures. Place your left hand flat against the sidewall of the tire, pushing down to keep bead below the drop-center (smallest diameter of the rim). See photo C.

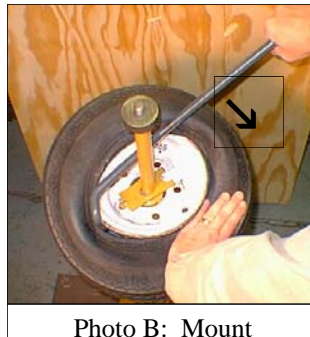
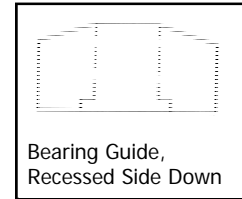

C. Four-lug and Five-lug wheel types (12" and smaller):

1. Place the rim over the center post with the valve stem facing up.
2. Install the hold-down plate with the pin facing down through any lug hole (see diagram). Turn the wheel clockwise until the pin of the hold-down plate contacts the nearest fin, centering the wheel. Place one or both spacer sleeves over post and secure with round nut. Hand tighten only. Caution: do not use machine without spacer sleeves. This will damage the threaded mounting shaft and make it unusable.

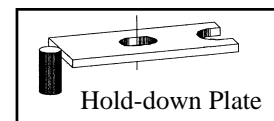

3. Once the rim is securely held in place, apply adequate amount of Bead-Eze® (or similar tire lubricant) to tire bead. Do not use flammable materials when servicing tires and wheels. Place tire on rim.
4. Cock the tire on the rim and hook the mount (curved) end of the Tire Snake™ over the exposed edge of the rim on side nearest you. Place your left hand flat against the sidewall of the tire to hold in place. Use caution when mounting to keep fingers from being pinched between rim and bead as tire is mounted to rim. See photo A. Grasp the Tire Snake™ at its farthest end, keeping it parallel with the rim. Pull the bar in a clockwise direction around the center post until first bead is mounted. See photos below.
5. To mount the second bead, follow the same procedures. Place your left hand flat against the sidewall of the tire, pushing down to keep bead below the drop-center (smallest diameter of the rim). See photo C.



Photo A: Mount



Photo B: Mount



Photo C: Mount

D. Four-lug and Five-lug wheel types for Passenger Car and Light Trucks:

1. Place the rim over the center post with the valve stem facing up.
2. Install the hold-down plate with the pin facing down through any lug hole (see diagram). Turn the wheel clockwise until the pin of the hold-down plate contacts the nearest fin, centering the wheel. Place the shaft support barrel over the threaded rod and secure with round nut. Hand tighten only.
3. Once the rim is securely held in place, apply adequate amount of Bead-Eze® (or similar tire lubricant) to the tire bead. Do not use flammable materials when servicing tires and wheels. Place tire on the rim.
4. Cock the tire on the rim and hook the mount (curved) end of the Tire Snake™ (see photo) over the exposed edge of the rim on side nearest you. The optional large Tire Snake™ is recommended (available separately). Place your left hand flat against the sidewall of the tire to hold in place. Use caution when mounting to keep fingers from being pinched between rim and bead as tire is mounted to rim. Grasp the Tire Snake™ at its farthest end, keeping it parallel with the rim. Pull the bar in a clockwise direction around the center post until first bead is mounted. See photo C.

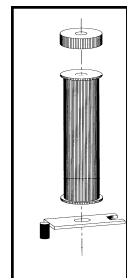

- To mount the second bead, follow the same procedures. Place your left hand flat against the sidewall of the tire, pushing down to keep bead below the drop-center (smallest diameter of the rim). See photo C.

E. ATV Deep Dish Rims

- Place the rim over the center post with the valve stem facing up.
- Place the 3/8" pin through any lug hole of the ATV wheel and turn the wheel clockwise until the pin contacts the nearest fin, centering the wheel on the machine. Install the ATV mounting plate (see diagram). Place the shaft support barrel over the threaded rod and secure with round nut. Hand tighten only.

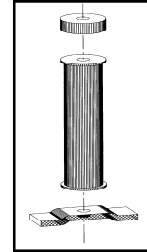

- Once the rim is securely held, apply adequate amount of Bead-Eze® (or similar tire lubricant) to tire bead. Do not use flammable materials when servicing tires and wheels. Place tire on rim.

- Using a side-to-side rocking motion, push the first bead over the rim. If bead can not be pushed over the rim, cock the tire on the rim and hook the mount (curved) end of the Tire Snake™ over the exposed edge of the rim on side nearest you. Place your left hand flat against the sidewall of the tire to hold in place. Use caution when mounting to keep fingers from being pinched between rim and bead as tire is mounted to rim. Grasp the Tire Snake at its farthest end, keeping it parallel with the rim. See photo A. Pull the bar in a clockwise direction around the center post until first bead is mounted. Due to additional width, you may have to compress the sidewall of the tire to allow the Tire Snake to remain in contact with the shaft support barrel. See photos below.



- To mount the second bead, follow the same procedures. Place your left hand flat against the sidewall of the tire, pushing down to keep bead below the drop-center (smallest diameter of the rim). See photo C.



Photo A: Mount



Photo B: Mount



Photo C: Mount

Maintenance and Care of your Tire Changing System

1. Routinely oil the threaded center post with any general purpose oil.
2. As you use your tire changing system, the threaded center post may turn and retract into the main body. You will have to unscrew it to return to its proper height.
3. Routinely check tightness of mounting bolts to ensure tire changing system is securely fastened.
4. Worn parts should be replaced. See replacement parts list for ordering information.

Replacement Parts and Accessories

- 1) 38600-02 Main Body for Bench Mount Model #38600
- 2) 38601-02 Main Body for Bench Mount Model #38601
- 3) 32124 Hand-Held Bead Breaker
- 4) 38600-03—T600-24 Bearing Guide
- 5) 38600-09—T600-9 Lug-Type Wheel Hold-Down Plate
- 6) 38600-21—ATV Wheel Hold-Down Plate and Pin
- 7) 38601-06—T601-6 6" Spacer Sleeve
- 8) 38600-05—T600-5 3" Spacer Sleeve
- 9) 38620-08—T600-8 Locking Nut
- 10) 34672 Small 24" Tire Snake™
(provided with 38600)
- 11) 34674 Medium 30" Tire Snake™
(provided with 38601)
- 12) 38601-16 T601-16 One 3/8" x 1-7/32" Clevis Pin
- 13) 31510-04 One 3/8" Washer
- 14) 31554-08 One Cotter Pin
- 15) 38601-18—T601-18 Shaft Support Barrel
- 16) 34670-02 Bead Breaker Foot
- 17) 38601-01—T601-1 Bead Breaker Handle
- 18) 34670-04 Bead Breaker Handle Grip
- 19) 38601-34 - 5/8-8 ACME ALLTHREAD X 14-15/16"

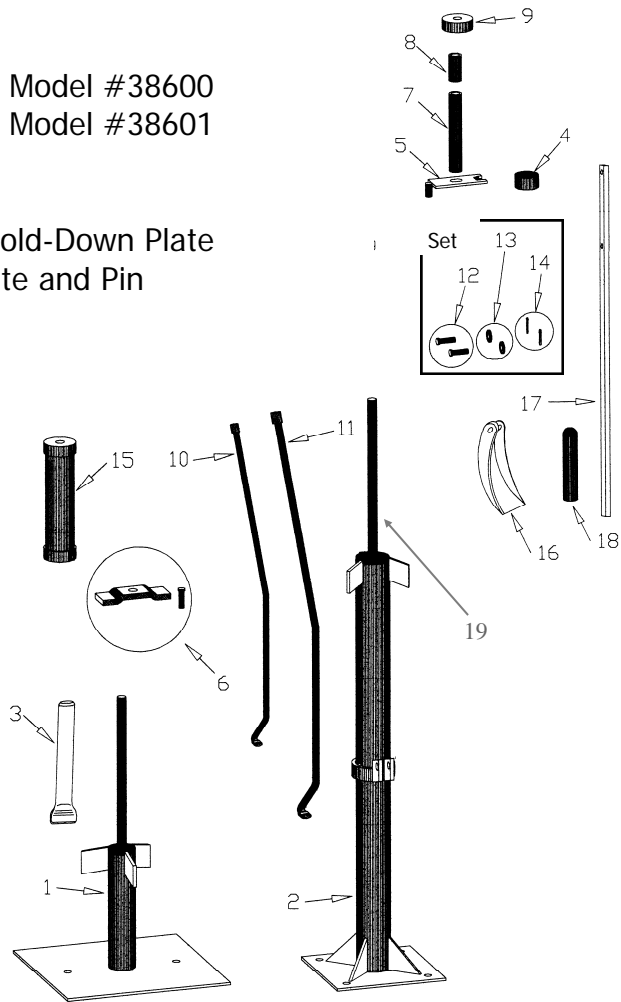

Also Available:

- 34678 42" Large Tire Snake™ - 14-15" Rims
- 198TCSV Instructional Video
- 32110 Two 9" Motorcycle Tire Irons
- 32117 Two 16" Motorcycle Tire Irons