



2013+ Ram 2500/3500 8-**10**"
Rear
Installation Instructions



Installation

1. Place the truck on a level surface and measure the pinion angle and write the angle down. This is important because you will need to put the axle back to this measurement after the installation. Also, take a measurement from the front of the axle to a location on each side of the frame. Write these measurements here. Pinion angle _____. Right side _____ Left side _____ **NOTE: All the bolts in this kit use a flat washer on each side of the bolt. Unless noted otherwise.** It is not required to remove the bed, but if you have the ability to do so, it will make the install much easier.
2. Jack up the rear of the frame so that the tension is off the leaf springs. Place a set of jack stands under the frame, block the tires so the axle won't move and place a jack stand under the pinion so it doesn't rotate. Remove the leaf springs, rubber bumpers fastened to the bottom side of the frame, and shocks. Keep these bolts that fasten the front of the leaf spring perch as they will be used in step 4 and the rubber bump stop bolts as they will be used to fasten the upper air bag mounts (part# 18941) in step 9.

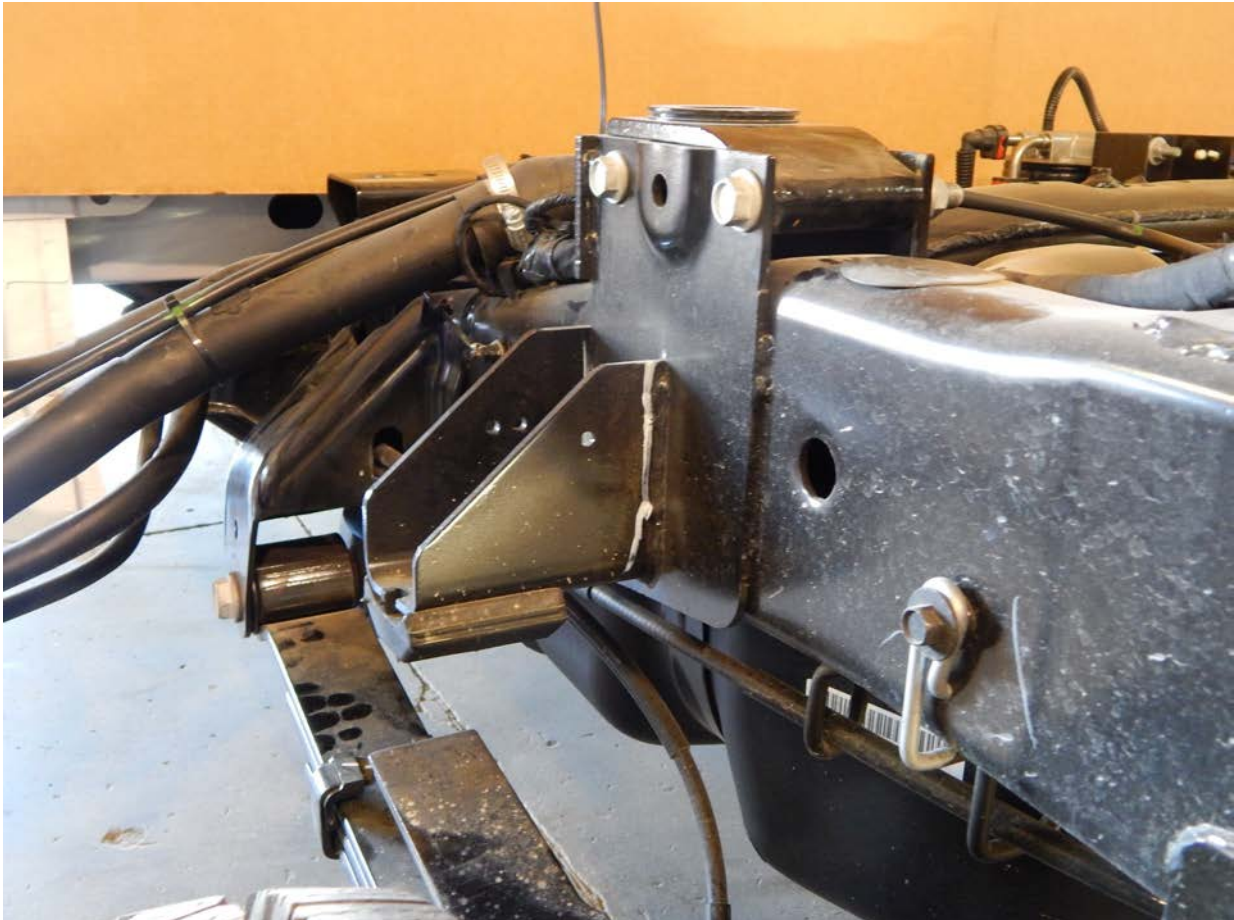

3. Locate the lower air bag mounts (part #18237 DS and 18244 PS) and the lower axle clamps (part#10043). Fasten the lower air bag mounts in place with the 5/8x8" bolts. Torque these to 150 ft/lbs.



4. Locate the upper trailing arms (part# 18357). They fasten to the lower air bag mounts with the 7/8x5" bolts. The other end fastens into the forward leaf spring perch with the factory bolt. Just start the nuts on the bolts. They will not need to be torqued until the install is complete. Once the install is done, the 7/8" bolt gets torqued to 275 and the factory leaf perch bolt gets torqued to 140 ft/lbs.

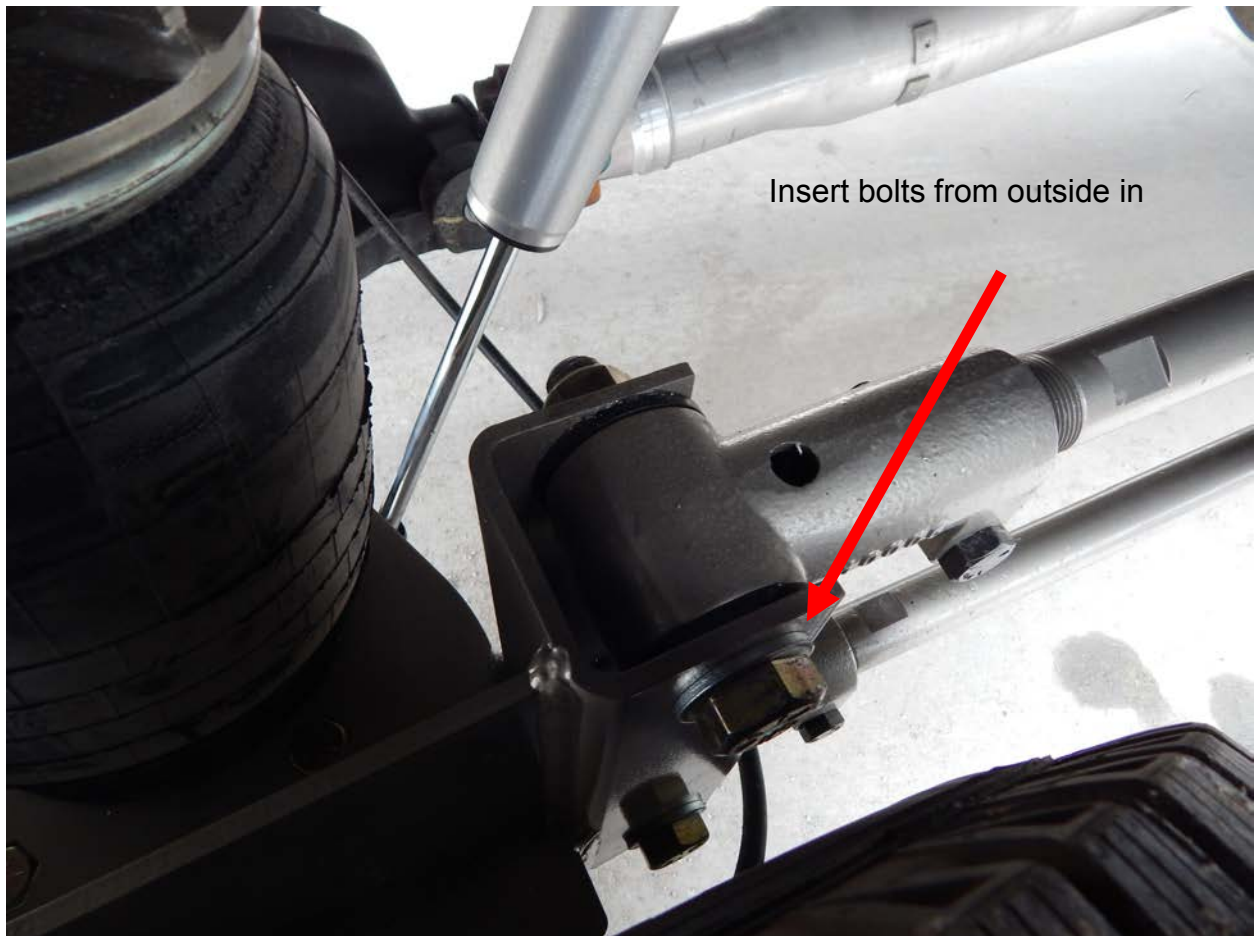

5. Locate the lower trailing arm side plates (part# 17991 DS Short box and 17992 DS Short box). Use the U bolts to clamp them around the frame. Torque the U bolts to 85 ft/lbs. It is also REQUIRED to weld the lower inside tab to the frame. Failure to weld will cause the bracket to move forward and back under hard acceleration and braking.

6. Locate the lower trailing arms (part# 18358 LB). They fasten into the lower air bag mounts with the 7/8x5" bolts and to the side plate with the 7/8x7" bolt. Make sure to install the 1 7/8" spacer on the inside of the knuckle and side plate.

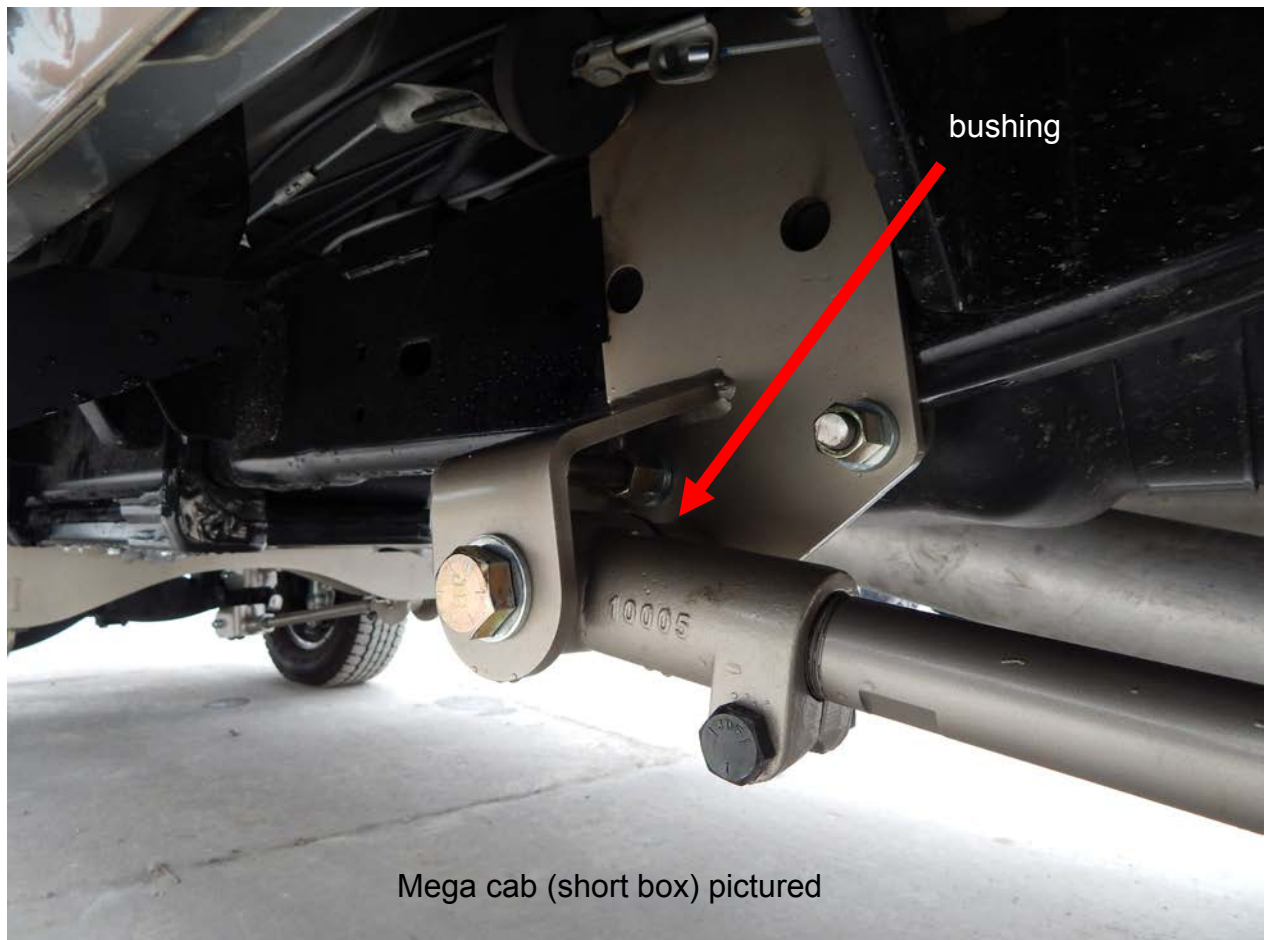

7. Locate the pan hard bar mount (part# 18256) and backing plate (part# 18218). It fastens to the drivers side frame rail just behind the axle with the four 1/2x5" bolts. Torque these bolts to 85 ft/lbs.

8. Locate the pan hard bar (part# 18323). Fasten it into the pan hard bar mount on the drivers side with the 3/4x 3 1/2" bolt. Fasten the other end into the passengers side lower air bag mount with the 3/4x 3 1/2" bolt. Make sure to use the supplied spacers on each side of the heim ends. Once installed, torque the 3/4" bolts to 175 ft/lbs.



9. Locate the upper air bag mounts (part# 18941). Use the bolts that held the rubber bumps tops in place to fasten the upper air bag mounts in place. Torque these bolts to 45 ft/lbs. Place the mounts so the large hole is towards the outside of the truck frame.



10. Locate the 8979 air bags (part# 10580). Fasten them to the lower air bag mount with the 1/2x 4 1/2" bolts, flat washer and lock washer. Torque this bolt to 25 ft/lbs. The top of the air bag fastens in place with the 1/2" and 3/4" lock washers and nuts. Torque the 1/2" nut to 25 ft/lbs and the 3/5" nuts to 35 ft/lbs.

11. Locate the sway bar, blue bushing, "D" rings, end links and upper end link mounting brackets (single rear wheel only part # 18321 DS and 18322 PS). Use the provided grease and slide the blue poly bushings over the sway bar. The grease helps prevent squeaking. The sway bar fastens to the bottom of the shock mounts located on the bottom of the axle with the 3/8 x 1 1/2" bolts. Install with sway bar ears pointed towards the rear of the truck. Torque these bolts to 35 ft/lbs

12. Locate the sway bar end links (part# 18494). On dual rear wheel trucks, the top of the end link fastens into the original over load leaf spring pad. Remove the factory rubber pad and drill the hole out to 17/32". Rock the drill for and aft lengthwise with the truck to provide the end link with articulation. The end links fasten to the outside of the sway bar with the 1/2x3" bolts. Make sure to place the large flat washer on the outside of the end link. Before the top of the end link is installed, slide the large flat washer on, then a red "donut" bushing and insert through the hole in the overload pad. Next, slide on another red "donut" bushing, large flat washer and lock nut. Just snug the lock nut up where the red bushing just begins to squish.

Thick Flat washer

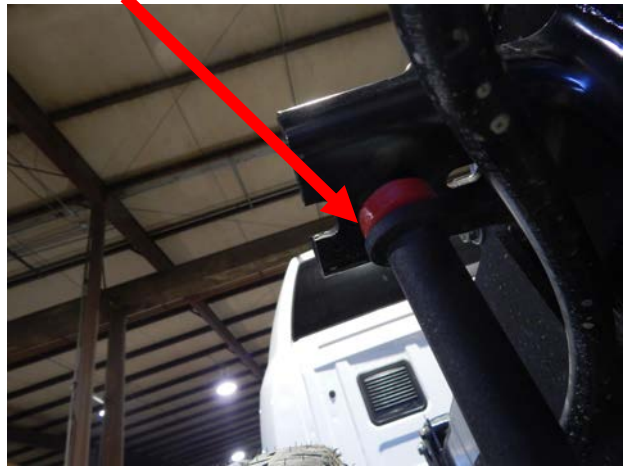

End links mount towards the tires

Large washer Drivers side



14. On single rear wheel trucks (SRW) require a different upper sway bar end link mount. As of the time these instructions were written, a picture was not available. The upper end link mount will be placed and welded where the factory overload pad is located. Use a 3" weld on each side of the bracket. Use the CAD drawings in the end of the packet to see the part.

On srw trucks, this bracket is not there. The srw kits a new bracket is supplied. It gets welded here.

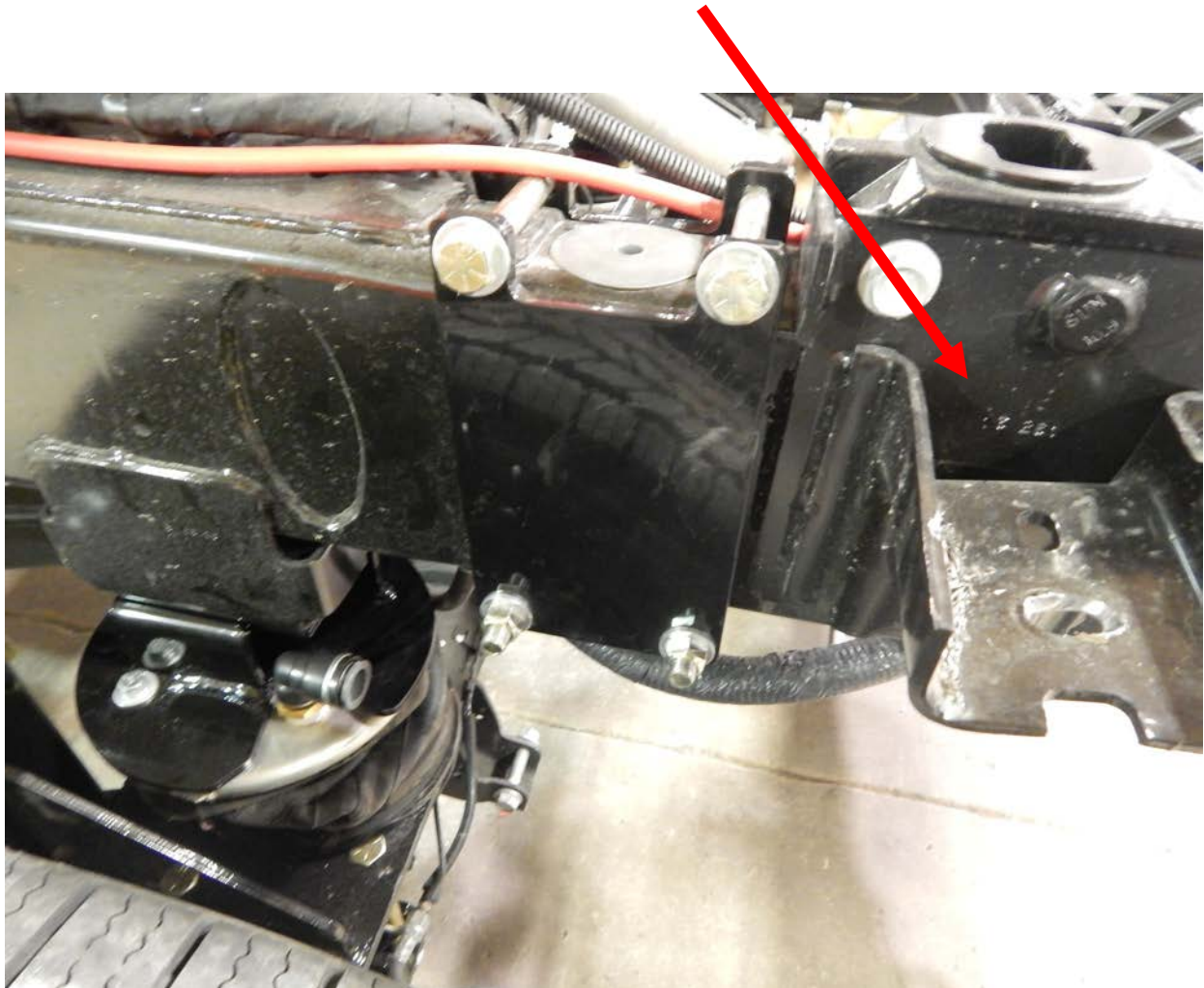

15. Locate the rear sensor or height control valve, plastic collar and linkage. It mounts to the side of the frame just behind the round cross member tube and just in front of the oval in the frame. Use a 3/16" drill bit and 1/4x20" tap to drill and tap the frame. 1/4x 1 1/2" bolts. Once the holes are tapped fasten with the 1/4" bolts and torque to 15 ft/lbs. Now fasten the plastic collar onto the lower trailing arm around 4" away from the edge of the cast knuckle. Once the Philips screws are tight, make sure the collar will not turn. If it does turn, remove it and use a grinder or file to trim the mating surfaces, then reassemble. NOTE: The sensors have a dead band in them the at the utmost top and bottom of the travel (sweep). You will want to extend the bags all the way and check the clearance as well as check the clearance with no air in the bags. You will need to see about a 1/16 between the sensor arm and the plastic back stop. Next fasten the linkage to it. Once the control system is installed, set the rear air bag to 12-12 1/2". That's where the air bag tends to ride the smoothest.

16. Next, go back to step 1 and check the measurements from step one. Use the trailing arms to set the pinion angle as well as the for and aft of the axle. Use the pan hard bar to set the axle right to left. Once the suspension is dialed in, go back and make sure all your bolts are torqued.

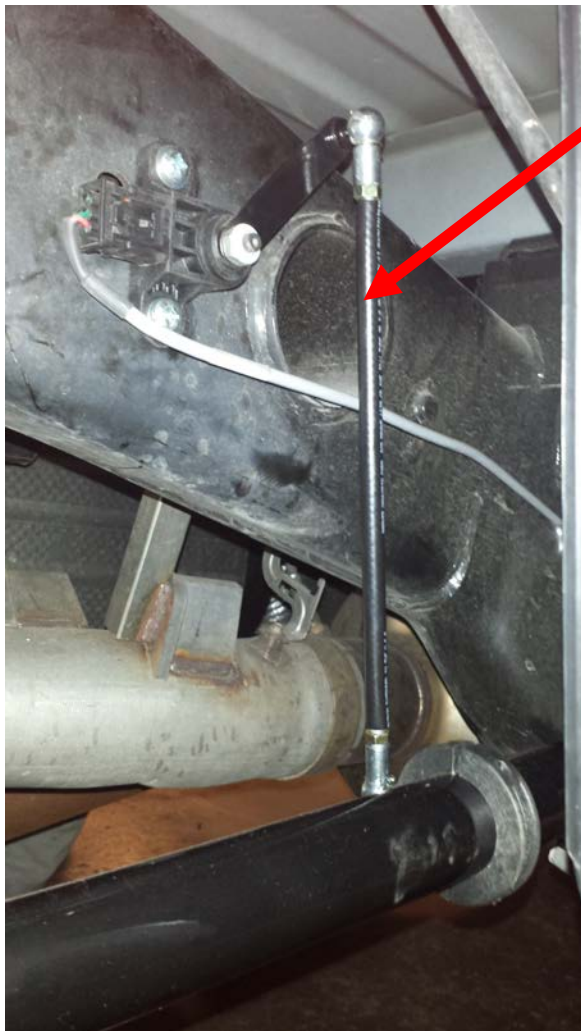

Linkage is 10 1/2"

**2013 Dodge 3500 G5 8-10"
Duel Rear Wheel**

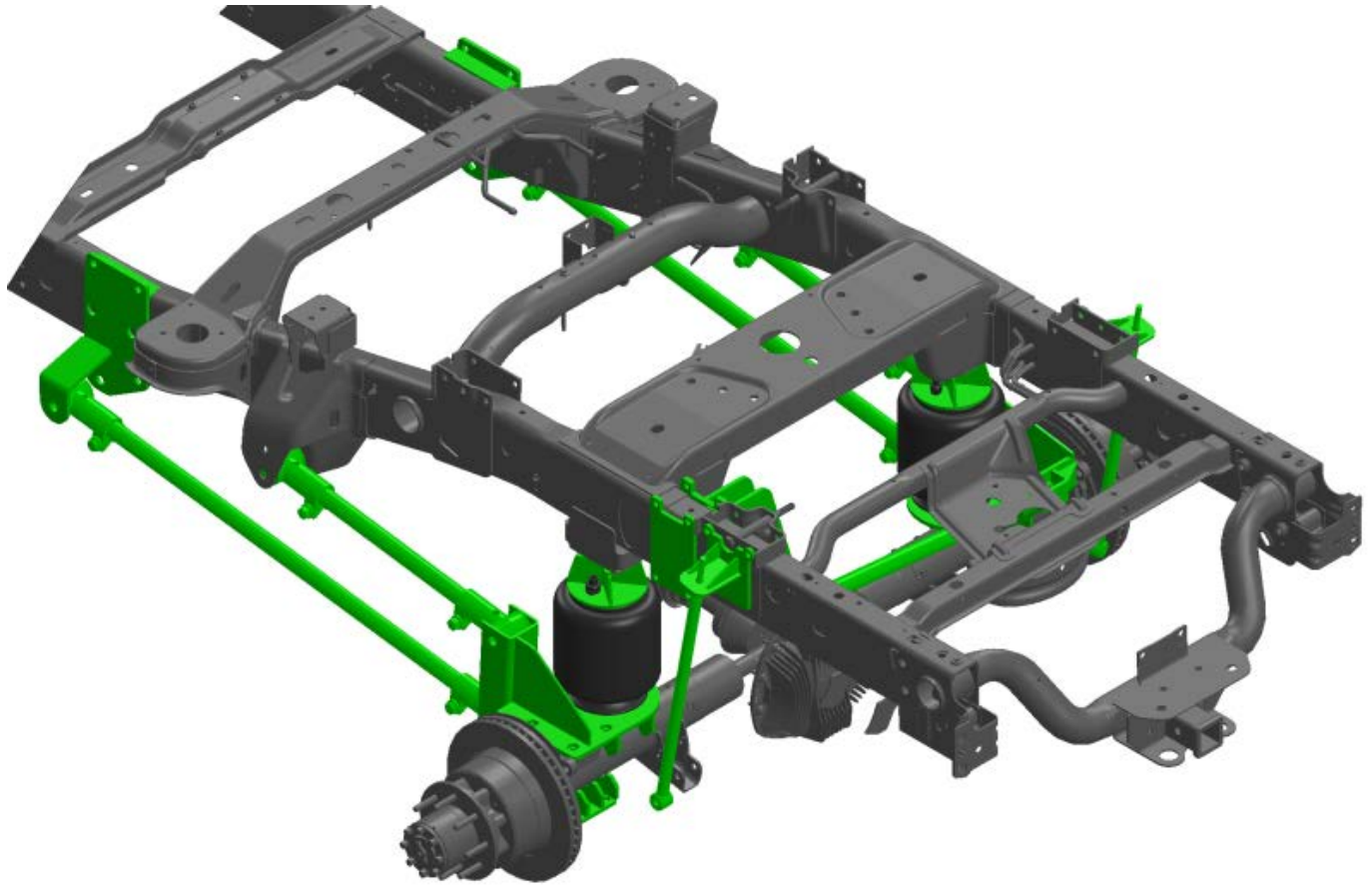

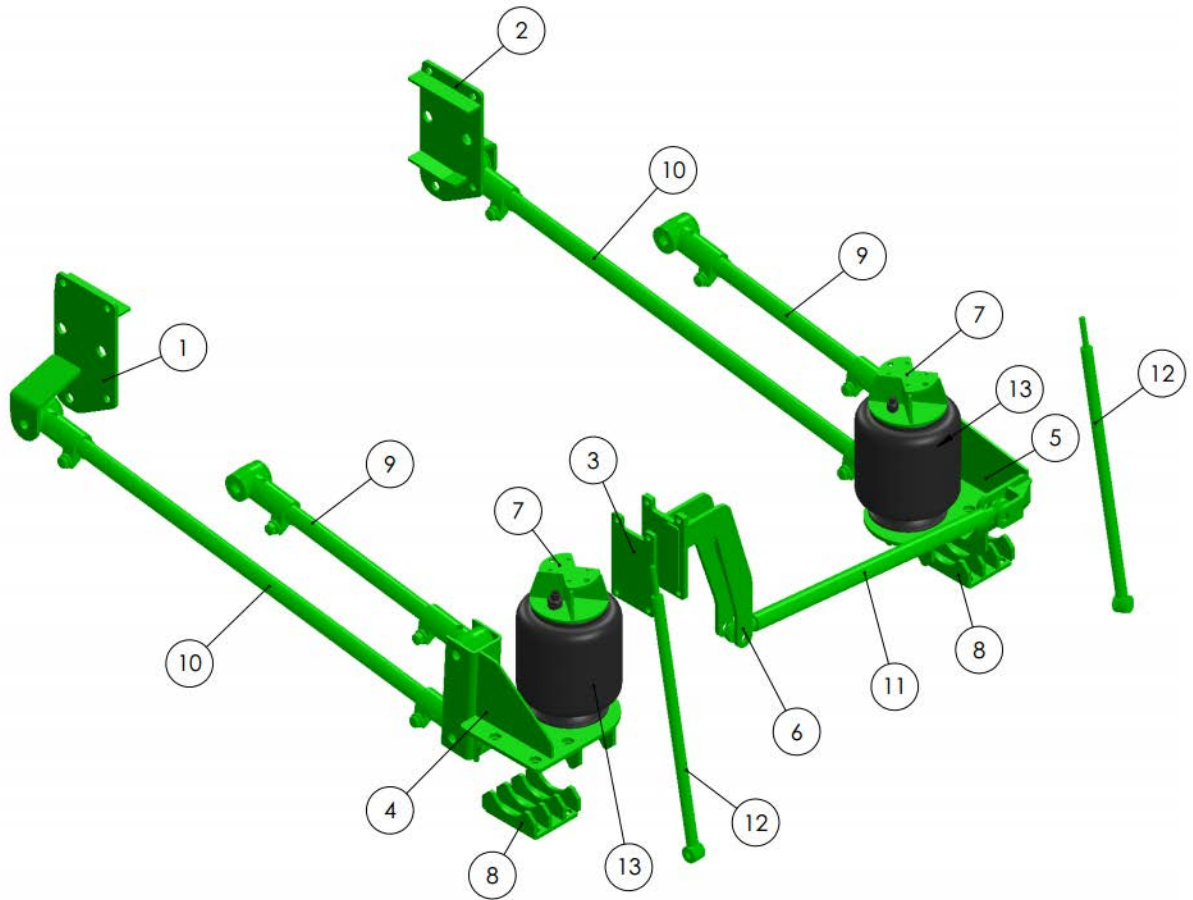

ITEM NO.	PART NUMBER	DESCRIPTION	DRW Parts/QTY.
1	17991	(DS) Side Plate (SB)	1
2	17992	(PS) Side Plate (SB)	1
3	18218	(PHB) Frame Mount	1
4	18237	(DS) Lower Bag Mount	1
5	18244	(PS) Lower Bag Mount	1
6	18256	(DS) Pan Hard Bar Frame Mount	1
7	18941	Upper Bag Mount, Rear	2
8	10043	4" Lower Round Axle Clamp	2
9	18357	Upper Trailing Arm Rear (Short)	2
10	18358	Lower Trailing Arm Rear (Long)	2
11	18323	Pan Hard Bar	1
12	18494	26.5" End Link	2
13	10580	BAG KIT - 8979	2