

# *kelderman air ride*

***“The difference in the ride is like night and day”***

***Inside this manual:***

<b><i>Tools required for installation</i></b>	<b><i>2</i></b>
<b><i>Preliminary and safety instructions, installation steps 1-5</i></b>	<b><i>2</i></b>
<b><i>Parts location, installation steps 6-7</i></b>	<b><i>3</i></b>
<b><i>Installation step 8</i></b>	<b><i>4</i></b>
<b><i>Installation steps 9-11</i></b>	<b><i>5</i></b>
<b><i>Installation steps 13-17</i></b>	<b><i>6</i></b>
<b><i>Self-leveling kit plumbing detail</i></b>	<b><i>7</i></b>
<b><i>Contact Information</i></b>	<b><i>8</i></b>

## *1999-2004 Ford Front System*

***This Kelderman Air Suspension system is designed for 99-04 Super Duty's and 99-05 Excursion***

***There are several advantages to equipping your truck with air ride suspension:***

- Improves the ride of the truck***
- Bolts into existing holes on truck frame***
- Keeps truck level with snowplow***
- Easy to install, maintenance free***



### ***1999-2004 Ford Front***



## *Warranty Disclaimer Notice Read Before Beginning Installation*

***Some Kelderman Air Ride kits contain both fine thread and course thread fasteners, fittings and air bag mountings. Before attempting to tighten***

***any threaded portion of the Air Ride, check to be sure the threads are the same size and thread count before attempting to tighten. Damaged or cross-***

***threaded fasteners, fittings and air bags caused by improper size. Thread count or misalignment are not covered by warranty.***



## 1999-2004 Ford

### Tools Required for Installation of the Air Ride Unit

**Before installation of the Air Ride unit, prepare a smooth, flat, hard surface and have all tools and equipment needed for the job. Chock the rear wheels of the truck, to prevent it from rolling forward or rearward.**

**Place a jack on each side of frame behind the front wheels, in the vicinity of the front seat. (1.1)**

#### **Tools and equipment required:**

**Cutting Torch**

**(2) Jacks**

**(2) Jack Stands**

**Wheel Chocks**

**Combination Wrench Set**

**Socket Set**

**Wedge or Pry bar (portable power with jaws / spreader)**

**Large "Zip" Ties**

**Brake Line Bending Tool**



**\*\*When raising or lowering the truck, keep jack stands in place to prevent the truck from falling, which could cause severe personal injury or death\*\***

### Installing the Air Suspension

**Step 1. Lift up the truck until the tires come off the ground. Place a jack stand under the truck frame and remove the wheels.**

**Step 2. Remove the factory shock, shock mounts.**

**Step 3. Place a jack under the axle. Remove the U bolts. Lower the jack under to remove some of the spring tension. Take a**

**wedge or pry bar and drive between the 2 springs. (1.2) Measure from the center of the spring forward 8 inches. Use a torch to cut the front half of the bottom leaf. Use a piece of flat metal to slide in between the springs to prevent cutting into the top leaf. (1.2) NOTE: If you are installing a lift kit with 5 leaves, remove the lower 2 leaves. DO NOT CUT ANY LEAFS!**



**On a lifted truck remove the lower 2 springs (leave the top 3 alone) 1.1**

## Installation Instructions (continued)

**Step 4. After the front piece of the leaf is cut, measure back 10" from the center of the spring. Mark the spot. Drive in a wedge, slide in the protective plate and cut the leaf. (1.3) (if the truck is lifted you will not cut any leaves)**

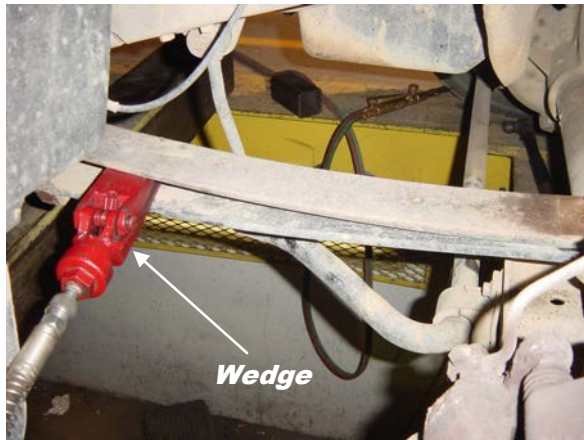

1.2



1.3

**Step 5. Locate the bottom air bag axle mount and bolt it to the axle using the factory "U" bolts. The shock mount faces towards the rear of the truck. (1.4 & 1.5)**

**Recommended torque ratings on bolts:**  
**3/8" grade 8 fine thread - 45 ft. lbs**  
**"U" bolts - 125 ft. lbs.**  
**Shock studs 45 ft.lbs**

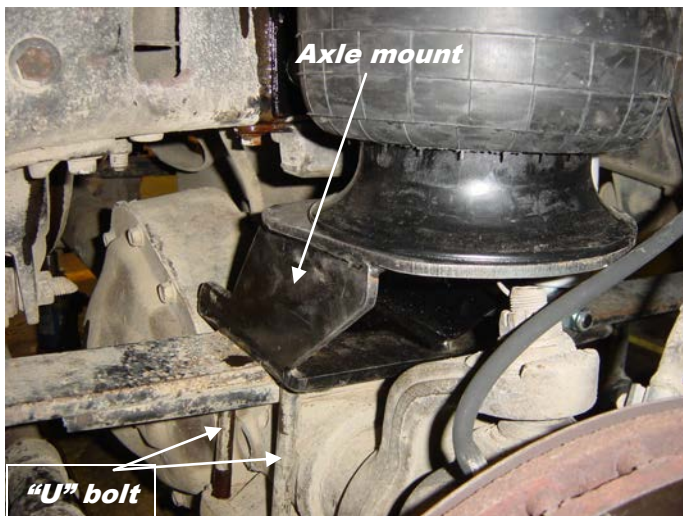

1.4



1.5



# Installation Instructions (continued)

**Step 6. The top air bag mount is bolted in place with the (4) 3/8" grade 8 bolts and lock nuts provided in the kit (put a flat washer on each side). Torque to 45 lbs (1.6 & 1.7)**

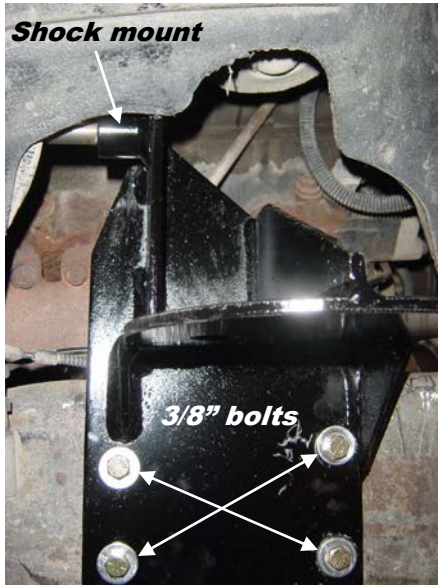

1.6



1.7

**\*\*NOTE: (1.8 & 1.9) You may want to cut part of the inner fender out right where the top of the shock sits. It will allow for easier tightening of the top shock nut.**

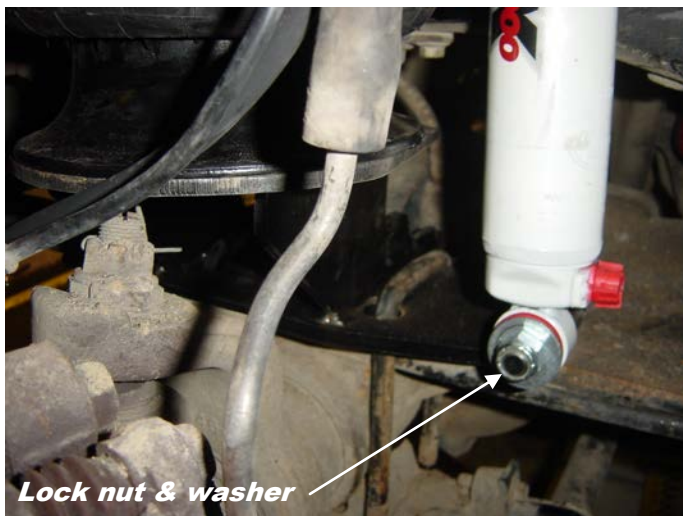

1.8



1.9

# 1999-2004 Newer

**Step 7. Mount the air bag in between the top and bottom mount. Tighten the nuts on top of the bag and the bolt that goes into the bottom of the bag. (2.0)**

**Step 8. Fasten the brass air line fitting in place. Route the air line into the engine compartment and put the Schrader valve on the end. You may want to “zip” tie the hose in a convenient location. Make sure the air line is away from any hot exhaust or moving engine parts. If installing a height control valve look on next page.**



**2.0**



**Step 10 The factory brake lines need to be bent up and back to clear the air bag when turning. Use extreme caution when doing this. We recommend a brake tube bending pliers. This will allow you to bend the brake line without kinking it. If the line kinks, replace it with a new line. (2.1)**

**2.1**



**The 3" kit has a 1.5" spacer that will go between the bottom of the air bag and lower air bag mount. A longer set of shocks is included for 3" kit (Rancho**

**If installing a height control valve, you will need to drill two 1/4" holes in the side of the frame and bolt the valve to the frame. Next, the steel block on the bottom of the shock needs to be drilled and tapped for the ball stud. With the air bag inflated to around 8.5" you will now cut the linkage rod to length so the height control arm is straight out.**

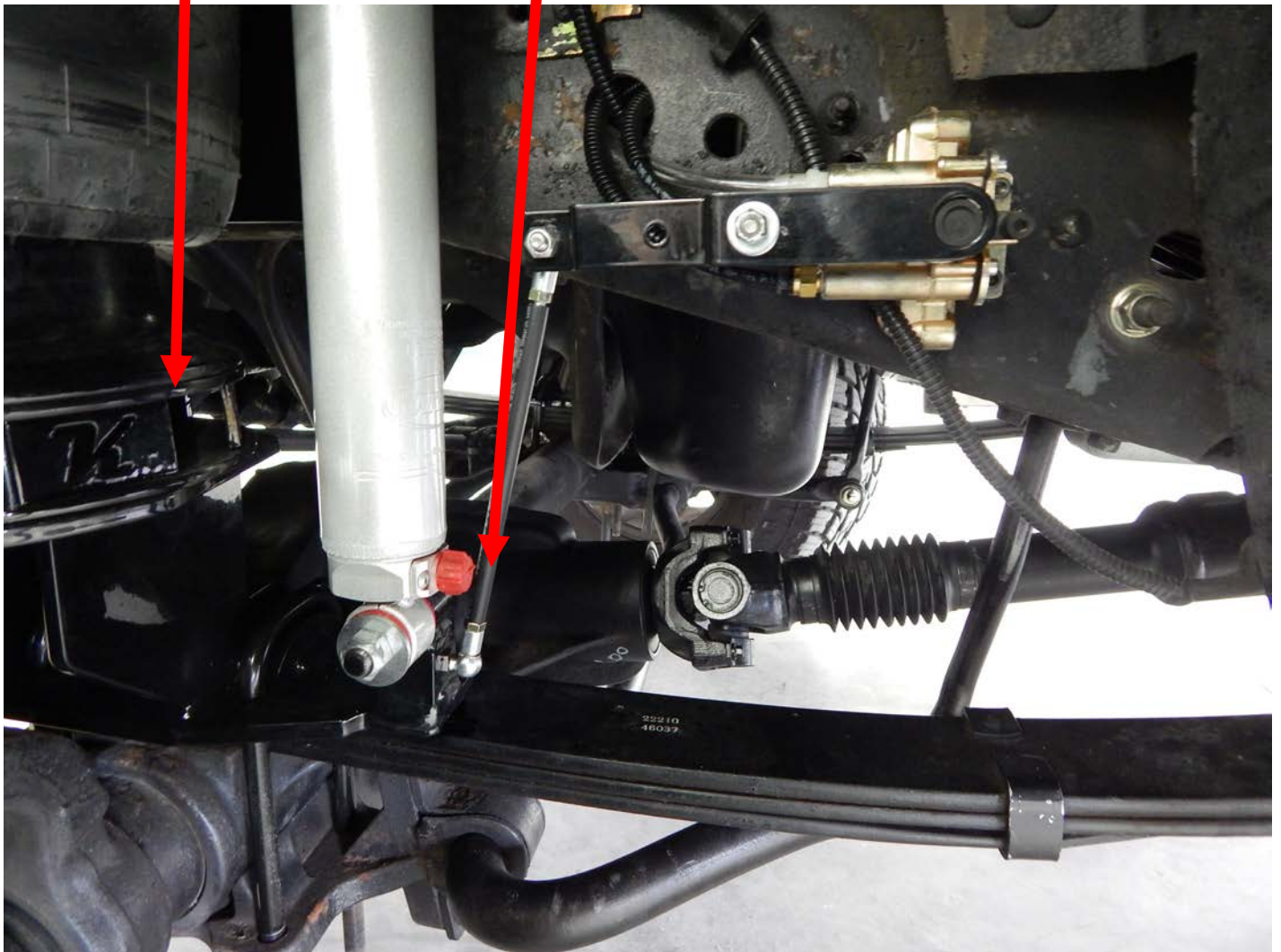

**1.5" lift pictured the bottom air bag plate is taller than stock**

**3.1**

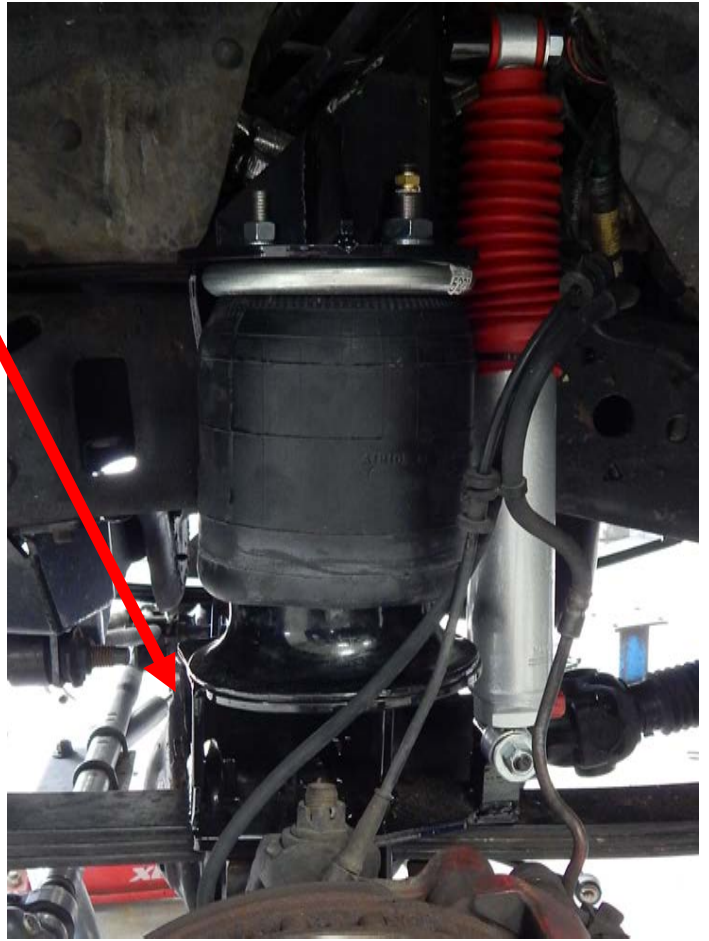

**3" lift pictured**



**3.2**

## *Installation Instructions (continued)*

**Step 12. Once you have bent the line, turn the steering wheel without the tire on it to check for clearance. Once you have clearance, put the tire on and make sure the brake lines will not rub on the tire. See pictures on previous page**

**Step 13. Use large zip ties to fasten the anti-lock wires to the brake line.**

**\*\*NOTE: It is very important that the brake lines and the anti-lock brake wires do not rub on the air bag or tire. Failure to check for this could cause serious personal injury or death.**

**Step 14. Repeat all steps on opposite side of truck.**

**Step 15. Add air to the air bags. The air bags are designed to ride best between 7.5-9.5". Start at 8" and then check the desired ride height. If doing a manual fill, record the pressure on each side and use as future reference. If doing a height control valve refer to page 6 and follow the instructions.**

**Step 16. If your kit has adjustable shocks, set them on setting 3. The higher the number, the stiffer the setting. 9 is the stiffest. (2.2)**



**Shock Adjustment Knob**

**2.2**

***There is no magic number for air pressure requirements. All you have to do is go by the truck ride height. Apply air to the system until the vehicle is at the stock ride height. Do not be surprised if the pressure is different between sides. If the kit you purchased has adjustable shocks, start at setting 3 and adjust the settings until you discover the best ride for you and your truck.***



ITEM NO.	PART NUMBER	DESCRIPTION	Default(PM)/QTY.
1	70001	MOUNT - FRONT BAG (PS 1.5)	1
2	70000	MOUNT - FRONT BAG (DS 1.5)	1
3	11623	MOUNT - FORD FRONT 0" (PS)	1
4	11624	MOUNT - FORD FRONT 0" (DS)	1

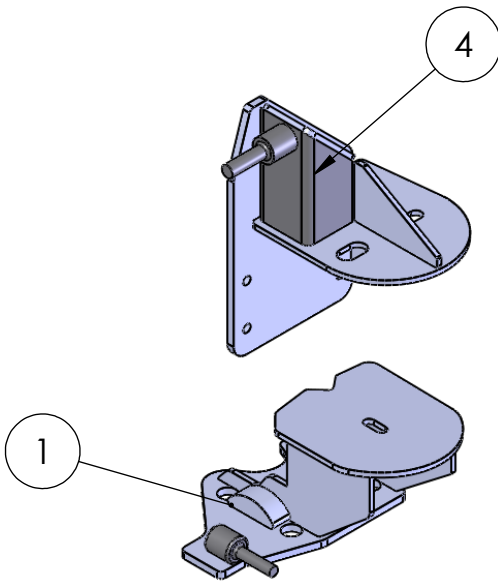
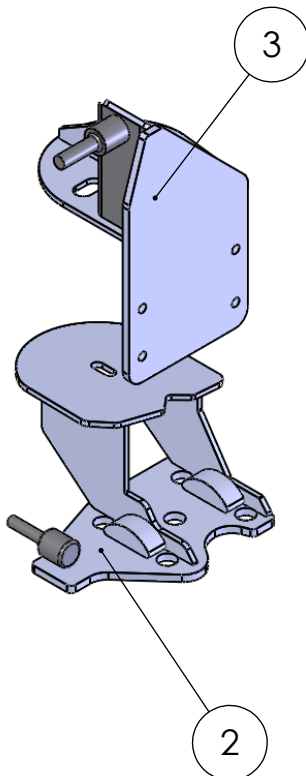

UNLESS OTHERWISE SPECIFIED: DIMENSIONS ARE IN INCHES TOLERANCES: FRACTIONAL $\pm 1/32"$ ANGULAR: MACH $\pm 1$ BEND $\pm 1$ TWO PLACE DECIMAL $\pm .030$ THREE PLACE DECIMAL $\pm .010$	<b>Design By:</b>	Zach Beltz 2014	<b>Project:</b> 99-04 F250/350 1.5" 2Bag Front	
	<b>Shelf # / Qty</b>			
	<b>Inventory</b>		<b>Description:</b> Kit - Ford 250/350 1 1/2" Lift	
	<b>Run Qty:</b>			
<b>MATERIAL</b>	PROPRIETARY AND CONFIDENTIAL THE INFORMATION CONTAINED IN THIS DRAWING IS THE SOLE PROPERTY OF KELDERMAN MFG. INC. ANY REPRODUCTION IN PART OR AS A WHOLE WITHOUT THE WRITTEN PERMISSION OF KELDERMAN MFG. INC. IS PROHIBITED.		<b>SIZE</b>	<b>DWG. NO.</b>
<b>FINISH</b>			<b>A</b>	<b>15755</b>
<b>WEIGHT</b> 60.32			<b>SCALE:</b> 1:12	DO NOT SCALE DRAWING

5

4

3

2

1