



2008 Ford F-450 Pick UP (not cab chassis) 4-Link Rear Installation Instructions



Installation

1. Before doing anything, measure the pinion angle and write the angle down. This is important because you will need to put the axle back to this measurement after the installation. Also, take a measurement from the front of the axle to a location on each side of the frame. Write these measurements here. Pinion angle _____. Right side _____ Left side _____ **NOTE: All the bolts in this kit use a flat washer on each side of the bolt.**

2. Jack up the rear of the frame so that most of the tension is off the leaf springs. Place a set of jack stands under the frame, block the tires so the axle won't move and place a jack stand under the pinion so it doesn't rotate. Remove the leaf springs. Remove the front overload pads. The best way to remove the riveted pads is to use a torch to cut the rivet heads off. Make sure that there are no fuel

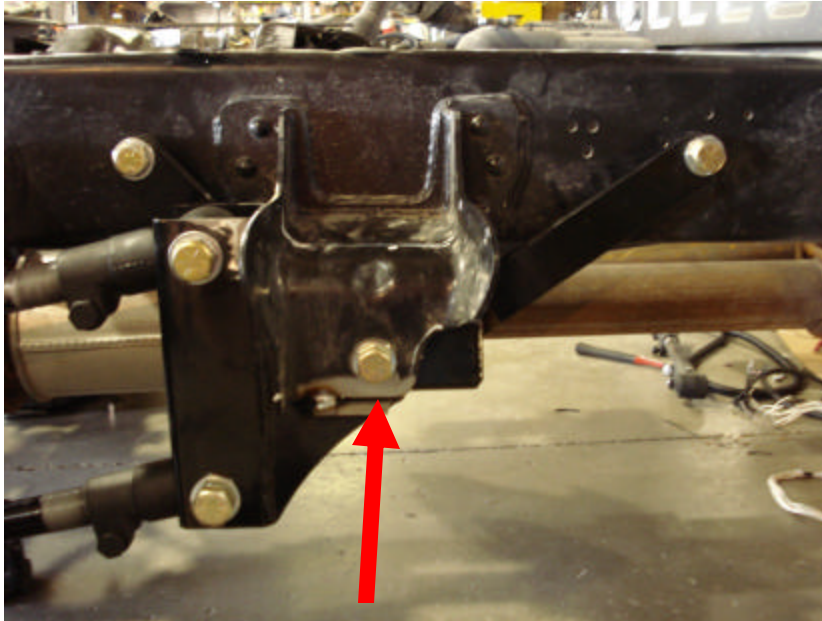

lines, brake lines, or wiring that can be damaged while cutting the rivets off.

3. Locate the front trailing mounts. These bolt to the front trailing arm mount with the 3/4x5". You also will need to weld the trailing arm mounts to the leaf spring perch. Use the pictures to see where to weld. It may be required to use a die grinder to open up the hole so the 3/4" bolt slides through.

4. Once you have the front trailing arm mounts in place, locate the front support bracket and fasten to the frame using the 3/4x3 1/2" bolts. Do not torque yet. Snug it up and then wing the support bracket towards the trailing arm mount. Grind away the powder coat off the support and trailing arm where the two parts meet. Next weld the two pieces together by welding on each side. Once welded, torque the 3/4" bolt to 250 ft/lbs.



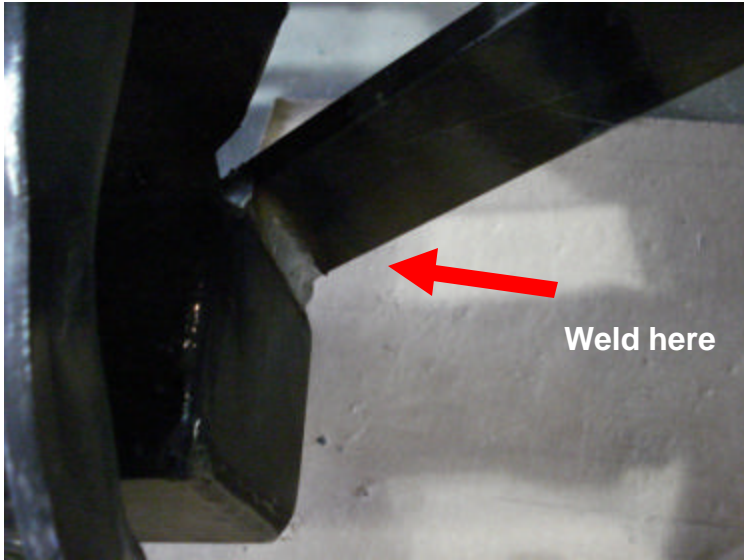

5. Locate the lower bag mounts
The driver's side mount is the one with the pan hard bar ears. Lo-

cate the 3/4x9 1/2" bolts. Locate two of the 5323 air bags. Slide the bolts through the bracket from the top down. Next fasten the air bag to the bracket using the 1/2x4" bolts, flat washer, and lock washer. Make sure the studs on the top of the air bags are parallel with the air bag mount. Tighten the 1/2" bolt to 35 ft/lbs.

6. Take the lower air bag brackets with the front air bag mounted to it and slide it over the axle. Use the center dowel pin to locate the bracket

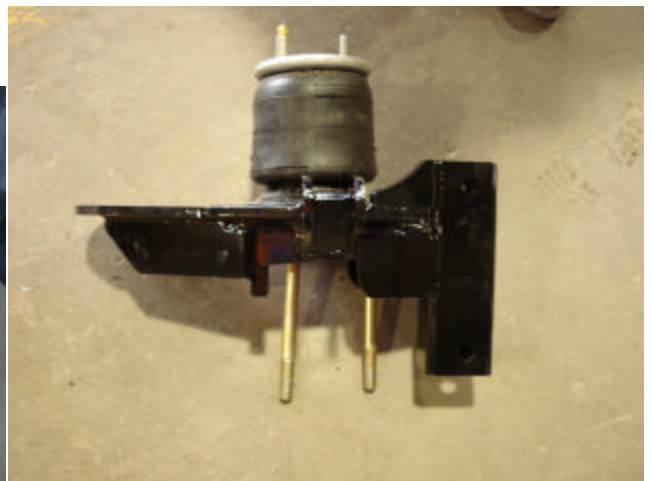

on the axle. Locate the lower axle clamp and slide it up under the axle.

Use the 3/4" nuts and flat washers to fasten the to mounts together. Torque the 3/4" bolts to 250 ft/lbs.

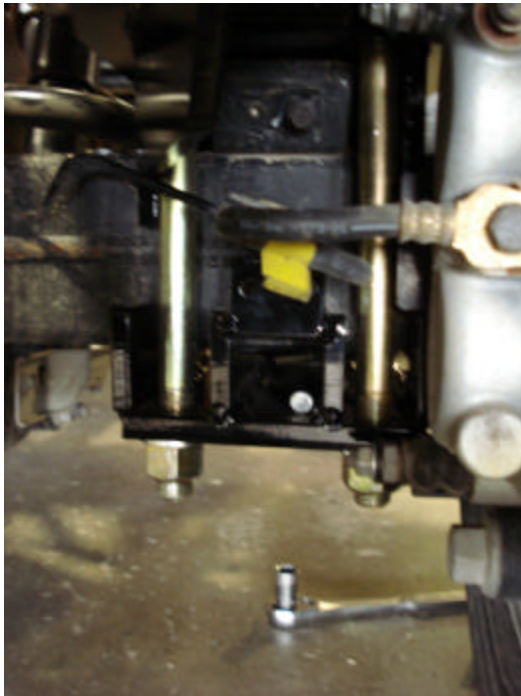

7. Locate the other two 5323 air bags. Fasten the bottom of the air bags to the lower air bag mounts with the 1/2x4" bolts, lock washer and flat nuts. Torque these bolts to 35 ft/lbs.

8. Locate the trailing arms. The upper trailing arms fasten into the front trailing arm mounts with the 7/8x5 1/2" bolts. Make sure to install the stabilizer bracket on the inside of the trailing arm mount. The stabilizer bracket bolts to the frame with the 3/4x3" bolt. The rear of the upper trailing arm mount fastens to the lower air bag bracket with the 7/8x5" bolts. The lower trailing arm mounts fasten to the front trailing arm mounts and air bag mounting brackets with the 7/8x5" bolts.

9. Locate the upper air bag mounts. They fasten to the frame with 1/2x2" bolts. When installing the drivers side, locate the pan hard bar mounting bracket and fasten it on the inside of the frame using the 1/2x2 1/2" bolts. Torque all the 1/2" bolts to 75 ft/lbs. Once the upper bag plates are installed, use the 1/2" and 3/4" nuts and lock washers to fasten the top of the air bags to the upper bag mounts. **NOTE: You will need to place a washer in between the upper bag mount and the frame where the frame has an indentation.**

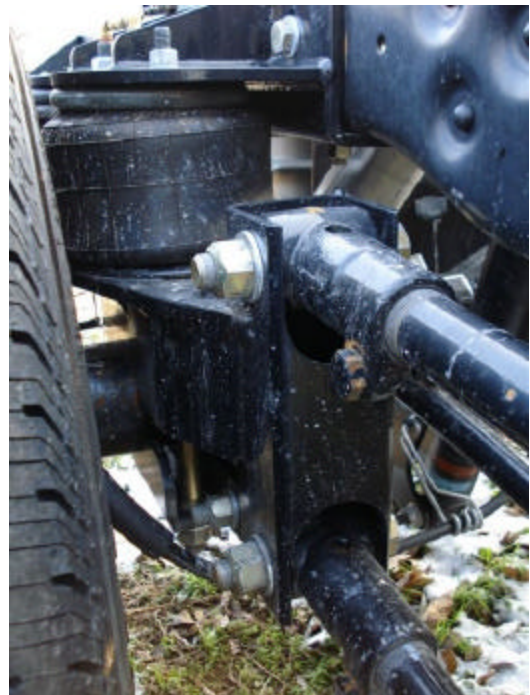
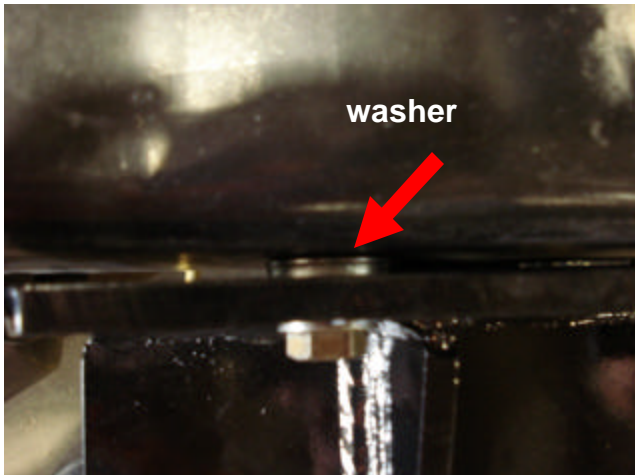

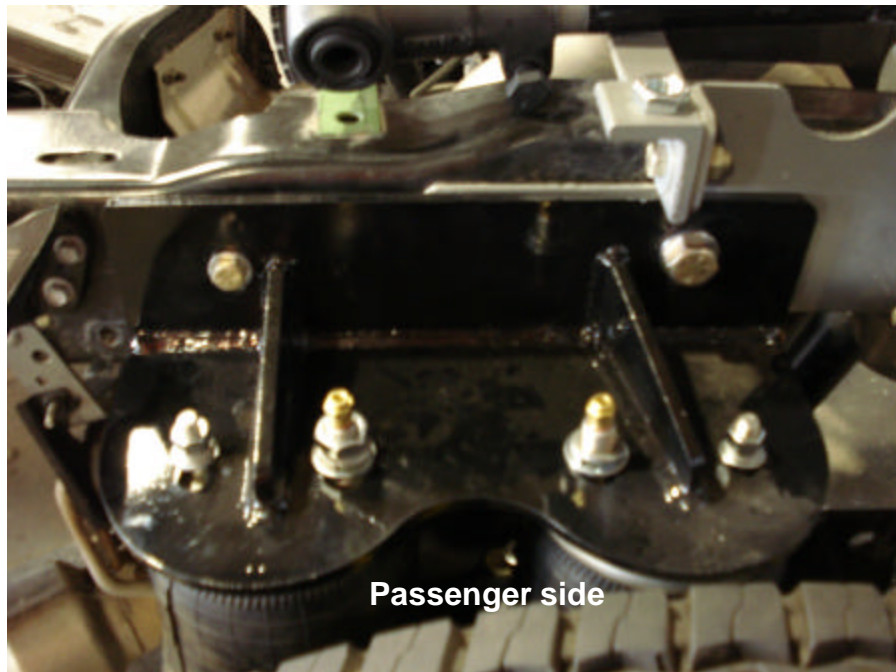

10. Locate the pan hard bar. The pan hard bar fastens into the lower air bag mount on the passengers side and into the upper pan hard bar mount fastened on the inside of the drivers side frame rail. Fasten in place using the 3/4x4" bolts.



11. Locate the heat shield (part # ISSU3). This mounts to the tail pipe on the passenger's side protecting the rear bag from excessive heat.



12. Alignment: Once all the components are installed and tightened, adjust the jack stands that are holding up the rear of the frame so that the distance between the upper and lower air bag mounting brackets is 7 1/2". Once this height is set, refer to the original measurements taken in step 1. After the adjustments are made, go ahead and tighten all the 7/8" bolts to 300 lb/ft. Next, tighten the pinch bolts to 75 ft/lb.

13. Plumbing of the system. Insert the fittings in the top of the four air bags. Locate the Neway height control valve and use the 1/2" x 1 1/4" bolts to fasten the height control valve to the front trailing arm bracket on the driver's side. Mount the ball to the end of the height control valve, fasten the lock collar to the lower control arm and connect the linkage between them.



14. Locate the compressor box. Mount the box somewhere on the frame, preferably on the driver's side frame rail. Use the wiring diagram provided at the end of the instruction packet to wire up the system. Also provided is a wiring diagram if you choose not to use the pre-made compressor box.



15. Locate the air tank. Mount find an area on the frame to mount it. Make sure the drain plug is facing straight down.



16. Once you have the compressor wired up, the air line going to the air tank, run an air line from the air tank to the bottom port of the height control valve. Locate the clear line and plastic fitting supplied with the height control valve and install it in the top port. This is the exhaust. Next locate the three brass "T" fittings. Connect the two air bags on each side with a "T" fitting. Next, connect the right side and left sides together with another "T" fitting. Last, connect this "T" fitting to the middle port on the height control valve.

17. Once the system is wired up and plumbed, turn on the ignition and the compressor will start running. Upon first start up when there is no air in the tank, it will take around 6-8 minutes until the system is charged, air bags filled. After the compressor shuts off, check for leaks. It works best to use soapy water or gas leak detector sold at hardware stores. Check all the fittings and connections in the entire system.

Self-Leveling Kit Wiring Diagram (shown with optional dump valve)

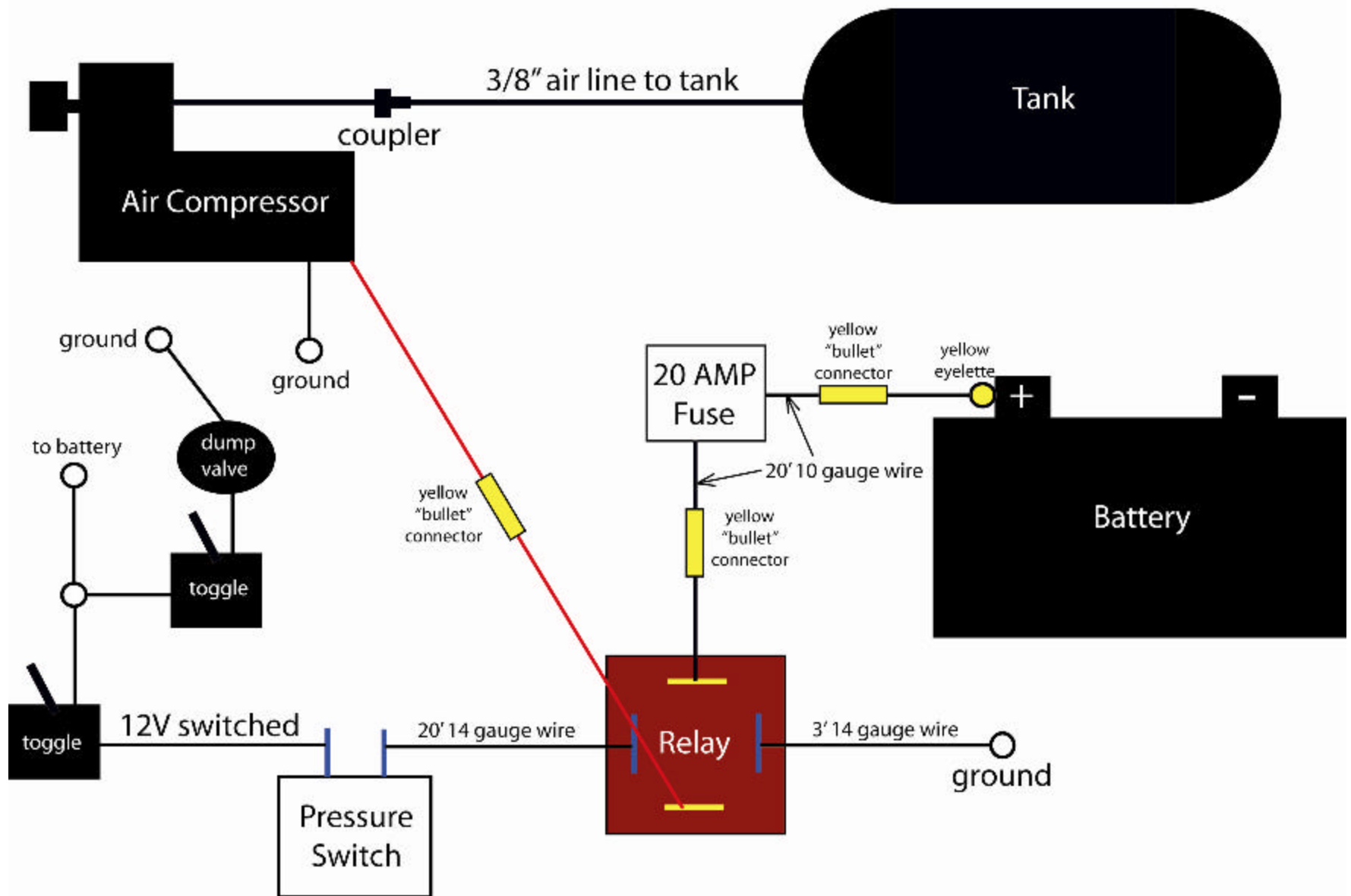

Compressor Box Self-Leveling Kit Wiring Diagram (shown with optional dump valve)

