

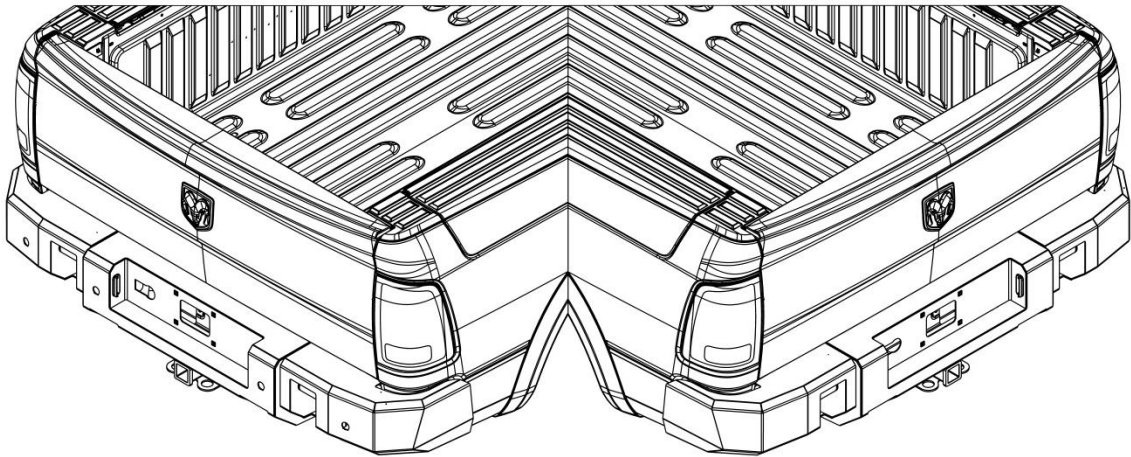

Alpha Series Rear Bumper Installation Manual

- 2010 Dodge Ram 2500-3500

Kelderman Alpha Series Rear Bumper



**With
Sensors**

**Without
Sensors**

- Contents

- Kit Numbers..... (3)
- Introduction..... (4)
- Safety..... (5)
- Bumper Removal (6)
- Bumper Preparation (8)
- Bumper Assembly..... (9)
- Bumper Installation.....(12)
- Parts Key.....(14)

Kit Numbers

- This installation manual covers the following rear bumpers.

Kit Number	Description
KLM-401041010-101000000	Dodge Ram 2500 – Alpha – With Sensors
KLM-401041010-102000000	Dodge Ram 2500 – Alpha – No Sensors
KLM-401042010-101000000	Dodge Ram 3500 – Alpha – With Sensors
KLM-401042010-102000000	Dodge Ram 3500 – Alpha – No Sensors

Introduction

- **Important**

It is important that the entire installation instructions be read thoroughly before proceeding with bumper installation.

- **Product Installer Responsibilities**

Installer is responsible for installing this product in accordance with Kelderman Mfg. Inc. specifications and installation instructions.

Installer is responsible for providing proper installation of vehicle components and attachments as well as required or necessary clearance for suspension components, axles, wheels, tires, and other vehicle components to ensure a safe and sound installation and operation of this product.

- **Product Owner Responsibilities**

Owner is solely responsible for pre-operation inspection, periodic inspections, maintenance, and use of the product as specified by Kelderman Mfg. Inc. Of particular importance is the re-torque of fasteners. This re-torque must be performed within 90 days or 1000 miles of this product being put into service.

- **Definition of Terms**

- **Warning:** Indicates a potentially hazardous situation which, if not avoided, could result in death or serious injury.
- **Caution:** A potential hazardous situation may result in property damage.
- **Note:** Provide information or suggestions that help correctly perform a task.
- **Torque:** When italicized "*torque*" alerts the installer to tighten fasteners to a specified value.

Safety

- **Your Safety and the Safety of Others is Very Important.**
Read and understand all safety precautions and instructions before installing this product.

- **CAUTION: Trucks Equipped with Parking Sensors or Other Like Devices.**
Relocation of these devices will alter the field of view. It is the responsibility of the owner to understand how these changes affect the operation of these systems.

- **This Product is Intended for Off-Road Use**
All liability for installation and use rests with the owner.

- **WARNING: Careless Installation Can Result in Serious Injury or Property Damage**
 - Wear eye protection.
 - Disconnect the battery before doing any work on the vehicle.
 - Work on flat level ground.
 - Ensure truck is properly supported by jack stands. Never work under a vehicle supported only by hydraulic jacks.
 - Take precautions when lifting product. Due to the size and weight of this product three people are recommended for installation.
 - Never work directly under the product until it has been securely fastened to the vehicle.
 - Avoid sharp, hot, and moving components when routing electrical cables.
 - If drilling inspect both sides of the surface and remove/relocate any objects located in the way.
 - Ensure all bolts are properly tightened before driving.

Bumper Removal

- 1: Disconnect the wiring to any lights, sensors, or other accessories mounted to the stock bumper. **NOTE:** Lower the spare tire to make accessing electrical connectors easier.
- 2: Remove the bolts located behind the license plate.

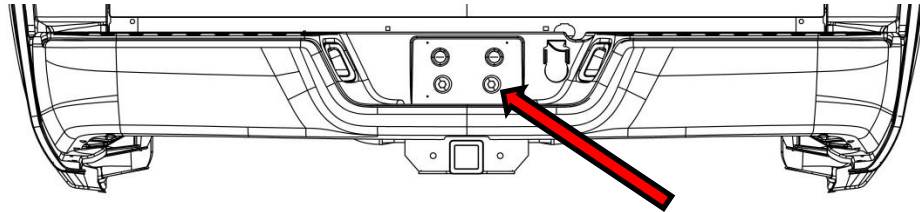

- 3: With the bumper supported remove the remaining four bolts from each side that fasten the bumper bracket to the frame. The bumper can now be removed.

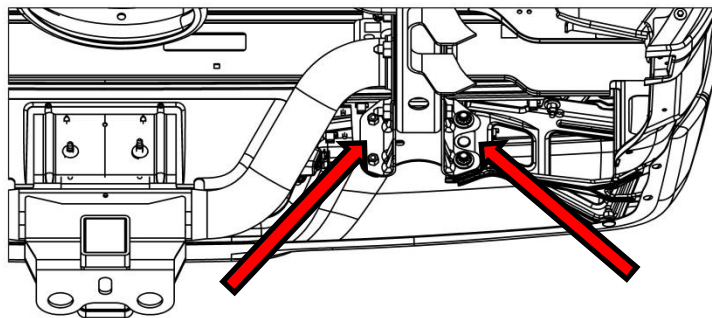

- 4: Remove the weld nuts from the four inner holes; drill these holes out to accept $\frac{1}{2}$ " bolts.

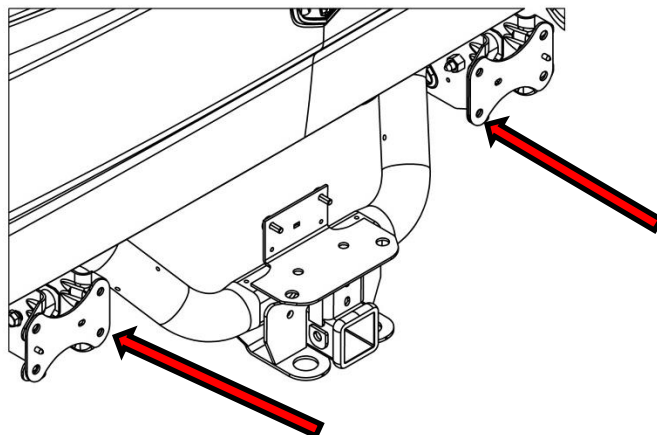

- 5:** If equipped remove the parking sensors from the stock bumper **NOTE:** Keep track of location. Spread the ears on the sensor bezel and push the sensor thru the back of the bumper.

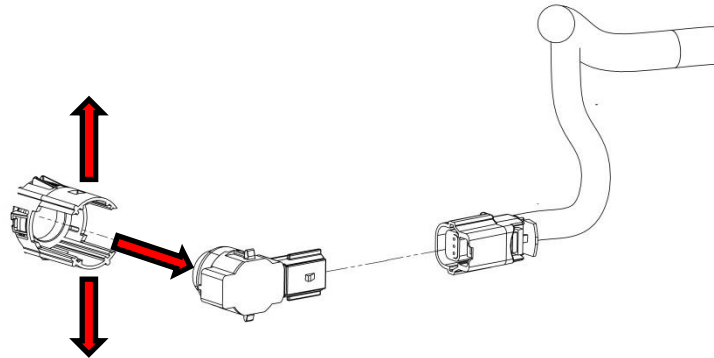

- 6:** Depress the tabs on the sensor bezel and push it thru the front of bumper.

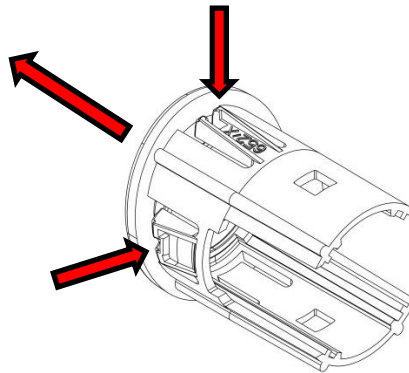

- 7:** Remove the license plate and trailer light plug.

Bumper Preparation

- Before painting open every box and locate all parts. There are several smaller bushing pieces, screens, and bolt tabs that are packaged separately inside the main box.

- **CAUTION:** This bumper has been designed to utilize a standard receiver pin. If you are using a locking pin or some other aftermarket pin check clearance with the bumper and make any necessary modifications before painting.

- **CAUTION:** Kelderman Mfg. Inc. cannot guarantee correct out of the box fitment across all light brands and sizes. The installer is responsible for test fitting all lights into the bumper and making any required modifications before the bumper is sent to paint. This bumper has been designed to utilize the following lights.
 - Rigid Industries E-Series 4 Inch Light
 - Hella 2KA-001-378-041 12V Incandescent License Plate Light
 - Hella 2KA-010-278-311 12V LED License Plate Light

- **Tow Hook Pocket Painting**
 - If a heavily textured thick coating is being applied, take note that buildup does not hinder the installation of the tow hooks. Each bumper is supplied with four rubber washers to let tow hooks rotate without damaging the paint. If thick coatings are applied, installation of hooks may only allow for the use of one or no rubber washers.

Bumper Assembly

- On a clean flat non-scratching surface place the bumper end caps (1 & 2) or (3 & 4) face down.
- Insert bumper mount bolting tabs (5) thru each pocket in the end caps. Use tape or zip ties to temporarily hold in place. **NOTE:** Short box dually installs, use the longer bumper mount bolting tabs (22). The longer studs allow the bumper to be shimmed back from the fender flares.

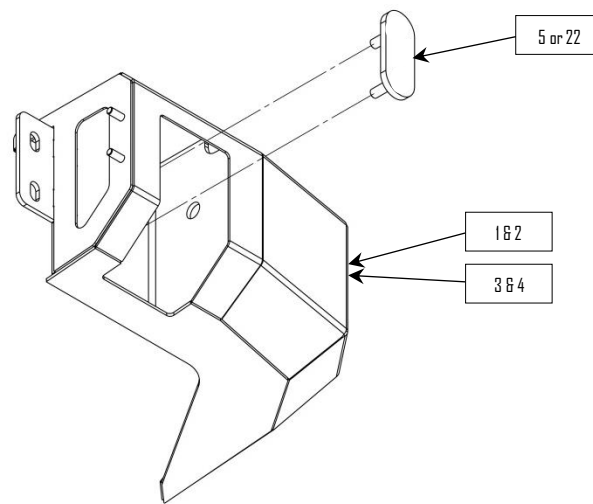

- Install the tow hooks (9) into the pockets in each end cap using the provided 7/8" hardware. Tow hooks (9) and rubber washers (8) go inside the pocket. Tighten the 7/8" nut (10) to the point where the tow hook will still spin but not freely.

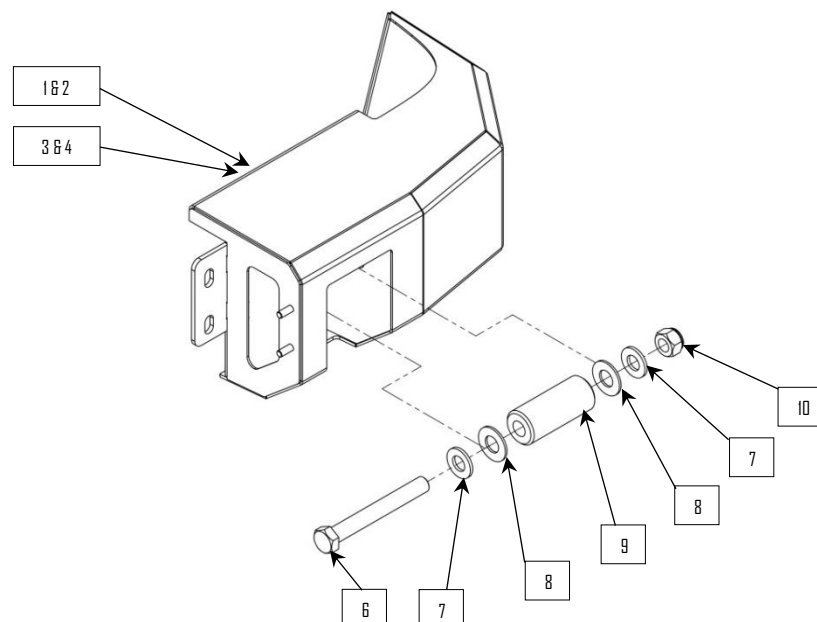

- If equipped install the sensors into the end caps by reversing the process from steps five and six. Be sure to install them back in the correct location. **NOTE:** If bezels will not snap into place file the tabs down a little at a time until they will catch.

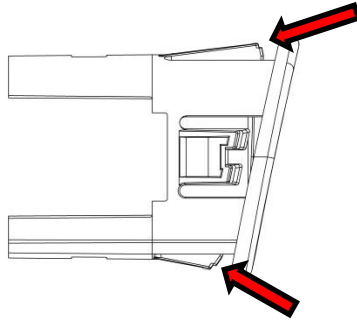

- On a clean flat non-scratching surface place the bumper center section (11 or 12) face down.
- Install the Hella license plate lights (13) using the provided #8 hardware. **NOTE:** Don't forget to install the bulb.

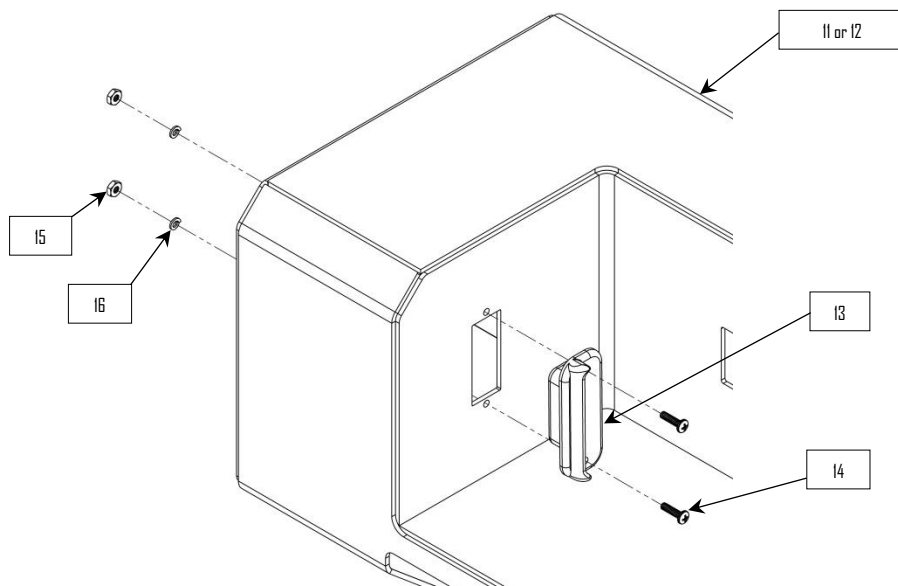

- If optioned, install the reverse lights into the center section.

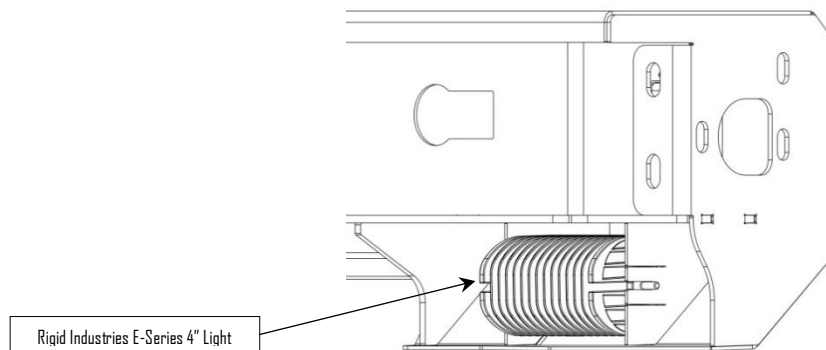

- Install two Rigid Industries 4 inch E-Series light (or similar light) using the hardware supplied with the light.
 - **NOTE:** The light mounting ears will deform and draw up tight to the light as they are tightened.
- Install the trailer light plug from step seven.
- Bolt the end caps onto the center section using the supplied 3/8" hardware. Position the tops flush with the center section. **NOTE:** While positioning use masking tape to protect painted surfaces that come into contact.

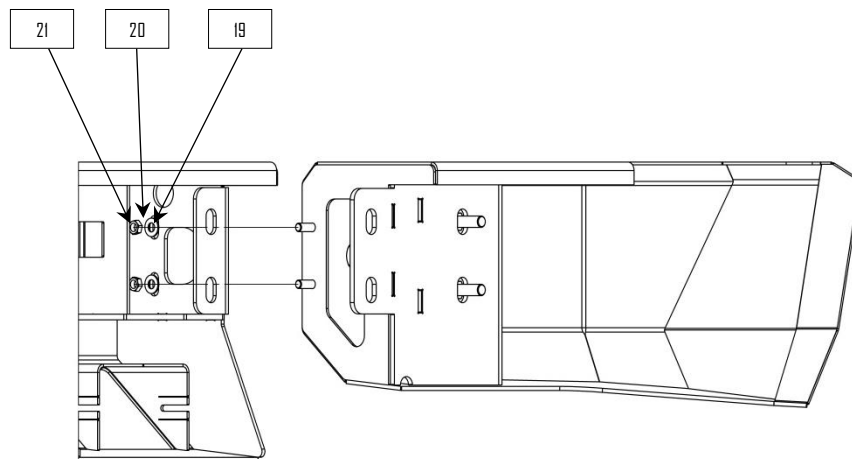

- Zip tie wiring to the tie downs welded inside the bumper.
- The Bumper is now ready for installation.

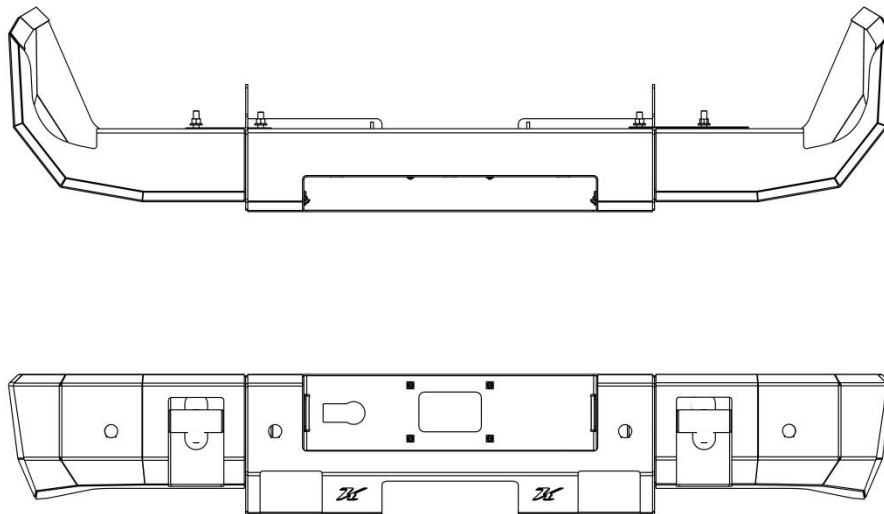

Bumper Installation

- 8:** Use the studs of the bumper mount bolting tabs (5) to position the bumper on the frame brackets. Use washer (25) and nut (26) to fasten the bumper to the mount.
NOTE: Short box dually installs, use the longer bumper mount bolting tabs (22). Use shims (27) to space the bumper away from the dually fender flares.

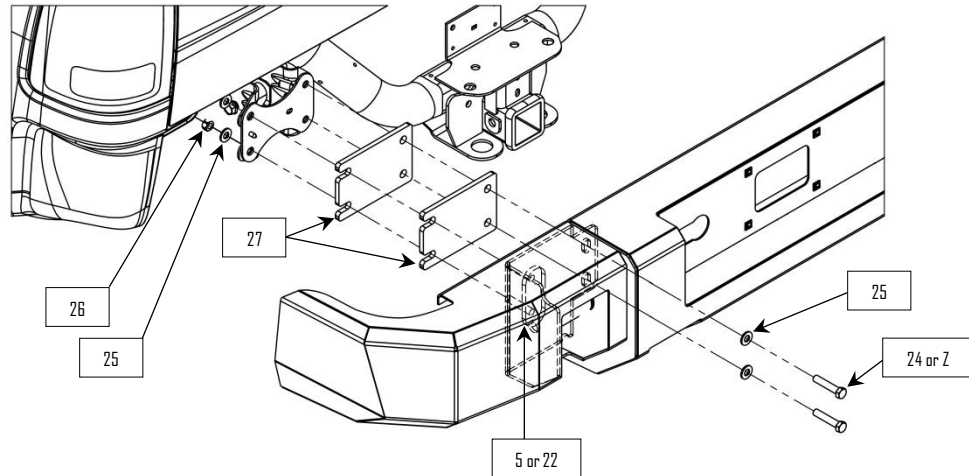

- 9:** Insert the remaining $\frac{1}{2}$ " hardware thru the bumper and bracket. **NOTE:** Short box dually installs use the longer $\frac{1}{2}$ " bolts (23).
- 10:** Align the bumper on the truck and tighten the mounting hardware.

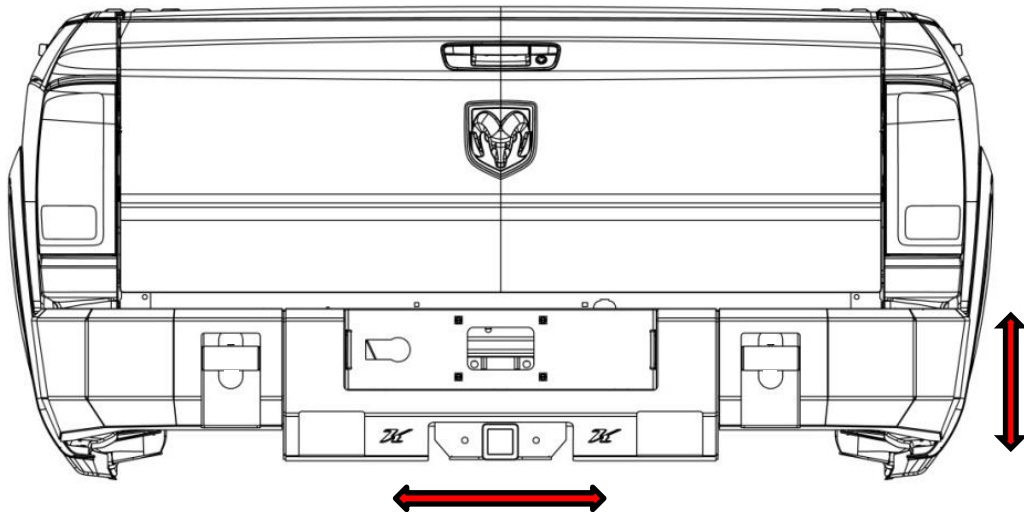

11: Torque all fasteners according to the chart below.

Bolt Size	Torque
1/4"-20	70 <i>in-lb</i>
3/8"-16	20 <i>ft-lb</i>
1/2"-20	50 <i>ft-lb</i>
9/16"-18	70 <i>ft-lb</i>
7/8"-9	250 <i>ft-lb</i>

12: Finish wiring accessories.

13: Press sq. nylon nuts (17) into bumper and install license plate using 1/4" screws (18).

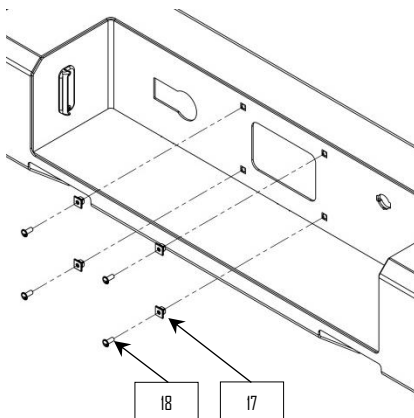

Parts Key

Item Number	Part Number	Description
1	31640	End Cap – With Sensor (PS)
2	31641	End Cap – With Sensor (DS)
3	31610	End Cap – Without Sensor (PS)
4	31616	End Cap – Without Sensor (DS)
5	31762	Bumper Mount Bolting Tab
6	12644	Bolt: 7/8"-9 X 7.00"
7	13010	Flat Washer: 7/8"
8	80043	Rubber Washer: 1" ID X 2" OD
9	31552	Tow Hook
10	13110	Lock Nut: 7/8"-9
11	31599	Center Section – Without Sensor
12	31602	Center Section – With Sensor
13	80042	Hella License Plate Light
14	14058	Phillips Screw: #8-32 X 5/8"
15	14052	Lock Nut: #8-32
16	14054	Flat Washer: #8
17	80054	Sq. Nylon Nut
18	14019	Slotted Screw: - 1/4"-20 X 5/8"
19	13002	Flat Washer: 3/8"
20	13046	Lock Washer: 3/8"
21	13142	Nut: 3/8"-16
22	31773	Bumper Mount Bolting Tab (2-1/2")
23	12017	Bolt: 1/2"-20 X 2-1/2"
24	12007	Bolt: 1/2"-20 X 1-1/2"
25	13004	Flat Washer: 1/2"
26	13124	Lock Nut: 1/2"-20
27	31772	Dually Box – Bumper Shim