



# KB PISTONS

## Installation Instructions For Hypereutectic Pistons

### **CALCULATING TOP RING END GAP**

Top Ring Example - Street Naturally Aspirated 4.000" bore x .0065" gap factor = .026" total top ring end gap.

**Second Ring: Set second ring end gap at .004 per inch of bore minimum.**

TOP RING END GAP FACTORS FOR ALL APPLICATIONS LOCATED

### **SPIRAL LOCKRING INSTALLATION**

RETAINER COMES UNSPRUNG. WE SUGGEST SPRINGING THE RETAINER ABOUT 1/2" TO 3/4" TO MAKE INSTALLATION EASIER. DO NOT OVER SPRING RETAINER. DO NOT USE LOCKS WHEN PRESS FITTING THE PIN.

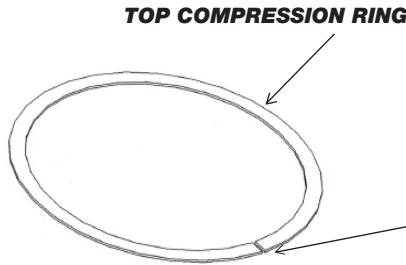

### **SPIRAL LOCKRING**



### **PISTON PIN C/L**

### **LUBE PIN HOLE**

1. USE HIGH QUALITY ASSEMBLY LUBE. NEVER USE GREASE.
2. PRESS FIT, USE ROD HEATER.
3. DO NOT USE LOCKS WHEN PRESS FITTING THE PIN.

### **TOP OF PISTON**

COMPRESSION HEIGHT IS THE DISTANCE FROM PIN CENTER LINE TO THE TOP OF THE PISTON. COMPRESSION HEIGHT DOES NOT INCLUDE THE DISH OR THE DOME.

### **COMP HGT**

### **PISTON PIN C/L**

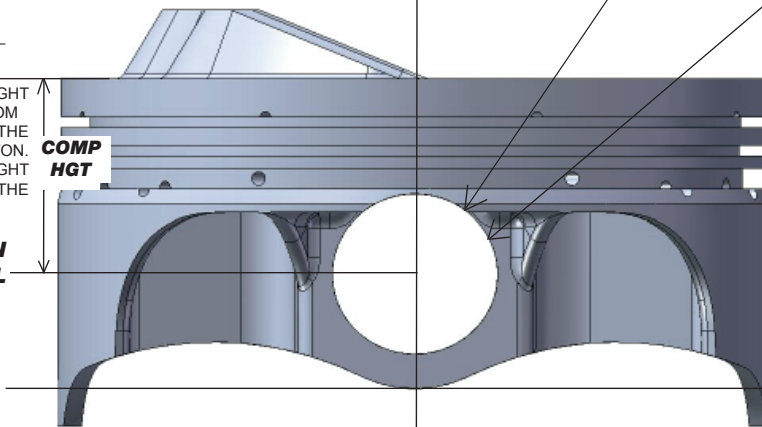

### **DIAL POINT**

MEASURE PISTON MAJOR AXIS (DIAMETER) HERE

### **Warranty Disclaimer**

Due to the nature of performance applications, the parts sold by United Engine & Machine Co. Inc. are sold without any express warranty or any implied warranty of merchantability or fitness for a particular purpose. UEM shall not, under any circumstances, be liable for any special, incidental or consequential damages, including, but not limited to damage, or loss of profits or revenue, cost of purchased or replacement goods, or claims of customers of the purchaser, which may arise and/or result from sale, installation or use of these parts.

UEM reserves the right to make product improvements or changes without notice and without incurring liability with respect to similar products previously manufactured.

The information contained in this instruction should not be considered absolute. Final decisions concerning the installation and use of these products are ultimately the responsibility of the customer. UEM makes no guarantee of warranty on emissions.

### **SPACER RING**

THE SPACER RING SUPPORTS THE OIL RAIL ON LONG ROD APPLICATIONS WHEN THE WRIST PIN IS INTERSECTING THE OIL GROOVE. THE SPACER RING SHOULD BE LOCATED IN THE BOTTOM OF THE OIL GROOVE. TO INSTALL, SPIRAL THE RING INTO THE OIL GROOVE. TAKE CARE NOT TO DISTORT OR BEND THE SPACER RING.

### **DIMPLE**

DIMPLE SHOULD BE PLACED OVER THE OPENING FORMED BY THE PIN INTERSECTING THE OIL GROOVE. THE RAISED SECTION SHOULD BE PLACED FACING DOWN.

### **SPACER RING**

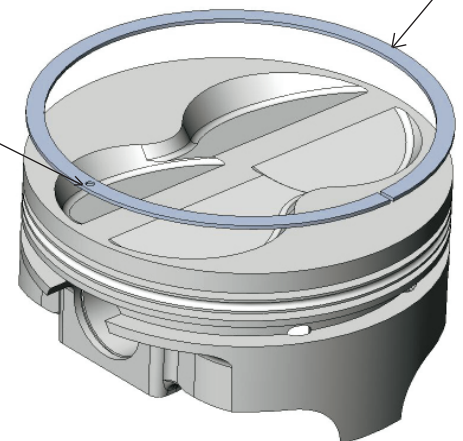

# General Clearance Guidelines

APPLICATION	Ring End Gap Factor	PISTON TO WALL CLEARANCE	
		4.000" - 4.100"	4.100" and up
STREET NATURALLY ASPIRATED	0.0065"	.0015" - .0020"	.0020" - .0025"
STREET TOWING	0.0080"	.0015" - .0020"	.0020" - .0025"
STREET NITROUS OR SUPERCHARGED	0.0080"	.0020" - .0025"	.0025" - .0035"
CIRCLE TRACK 2 BBL/RESTRICTOR GAS	0.0070"	.0015" - .0045"	.0020" - .0050"
CIRCLE TRACK UNRESTRICTED	0.0080"	.0025" - .0045"	.0030" - .0045"
CIRCLE TRACK ALCOHOL INJECTION	0.0080"	.0025" - .0045"	.0025" - .0050"
CIRCLE TRACK ALCOHOL CARB	0.0080"	.0030" - .0045"	.0030" - .0050"
DRAG GASOLINE	0.0075"	.0015" - .0045"	.0020" - .0045"
DRAG ALCOHOL	0.0065"	.0015" - .0045"	.0020" - .0045"
DRAG SUPERCHARGED OR NITROUS	0.0095"	.0020" - .0045"	.0025" - .0050"
DRAG SUPERCHARGED ALCOHOL	0.0085"	.0015" - .0045"	.0025" - .0045"
MARINE NATURALLY ASPIRATED	0.0080"	.0030" - .0045"	.0035" - .0050"
MARINE SUPERCHARGED	0.0090"	.0030" - .0045"	.0035" - .0050"
AIR COOLED BAJA	0.0075"	.0030" - .0045"	.0035" - .0050"
PROPANE	0.0065"	.0015" - .0045"	.0020" - .0045"

Modern piston design locates the top ring higher for improved performance. A high top ring operates at higher temperatures and requires a larger top ring end gap. To find the proper ring end gap, multiply your bore size by the ring end gap factor listed on the chart (i.e., Street Naturally Aspirated 4.000" bore x .0065" gap factor = .026" total top ring end gap).

Your hypereutectic performance piston will expand less than typical cast or forged pistons. Because of this and the wear characteristics of the hypereutectic alloy, you can run tight piston-to-wall clearances.

NOTE: Hypereutectic piston engines will require 2-4 degrees less total ignition timing. One key to top performance is to have all cylinders longing for the same timing numbers. Equal air flow, fuel mix, quench, chamber temperature, swirl, and compression at each cylinder work to this end.

**Final piston clearance should be based solely on the demands of your application.**

Factors such as fuel type, altitude, outside temp., humidity, tune up, and many others factors need to be taken into account for your final clearance.

## PISTON ORIENTATION

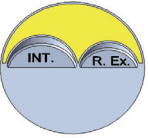

**QUENCH AREA (YELLOW):** Quench is the area behind the valves. This area should match the flat area on your cylinder head. Proper quench promotes cooling of the piston and can be effective in reducing detonation.

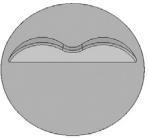

**NOTE:** Some pistons come with symmetrical valve reliefs. This allows the piston to be fitted to any cylinder with just orientating the quench area towards the center of the block.

**CHECKING CYLINDER HEADS:** Check cylinder heads with clay or some other method before balancing and final assembly to assure proper piston to head clearance. .040" minimum clearance.

- CHEVY** 302, 305, 327, 334, 350, 377, 383, 400, 434
- CHRY** 318, 340, 360, 383, 400, 408, 440, 450, 463, 468, 493, 498, 505, 520
- BUICK** 455
- PONTIAC** 389, 400, 428, 455

**CHEVY V6 4.3L / 262 CI**  
4 LEFTS AND 2 RIGHTS

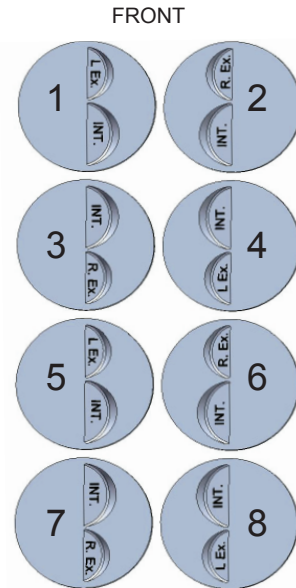
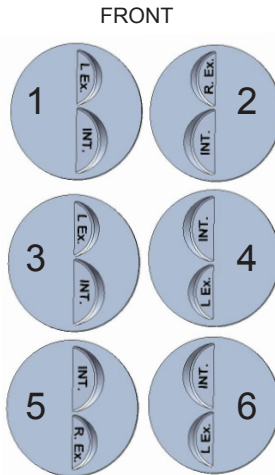

**FORD** 289, 302, 331, 347, 351W, 372W, 383W, 393W, 408W, 416W, 418W

**FORD** 390FE, 406FE, 410FE, 427FE, 428FE, 438FE, 452FE, 455FE, 482FE

**FORD CLEV** 351C&W/C, 377C, 387C, 402C  
**FORD BB** 429, 460, 502, 520, 545  
**CHEVY BB** 396/402, 427, 454, 489, 502, 540

**TOYOTA** 22R 1985 AND NEWER

