

KARGO MASTER[®]

WE PUT EVERYTHING WITHIN REACH.

Instruction Guide

8012A

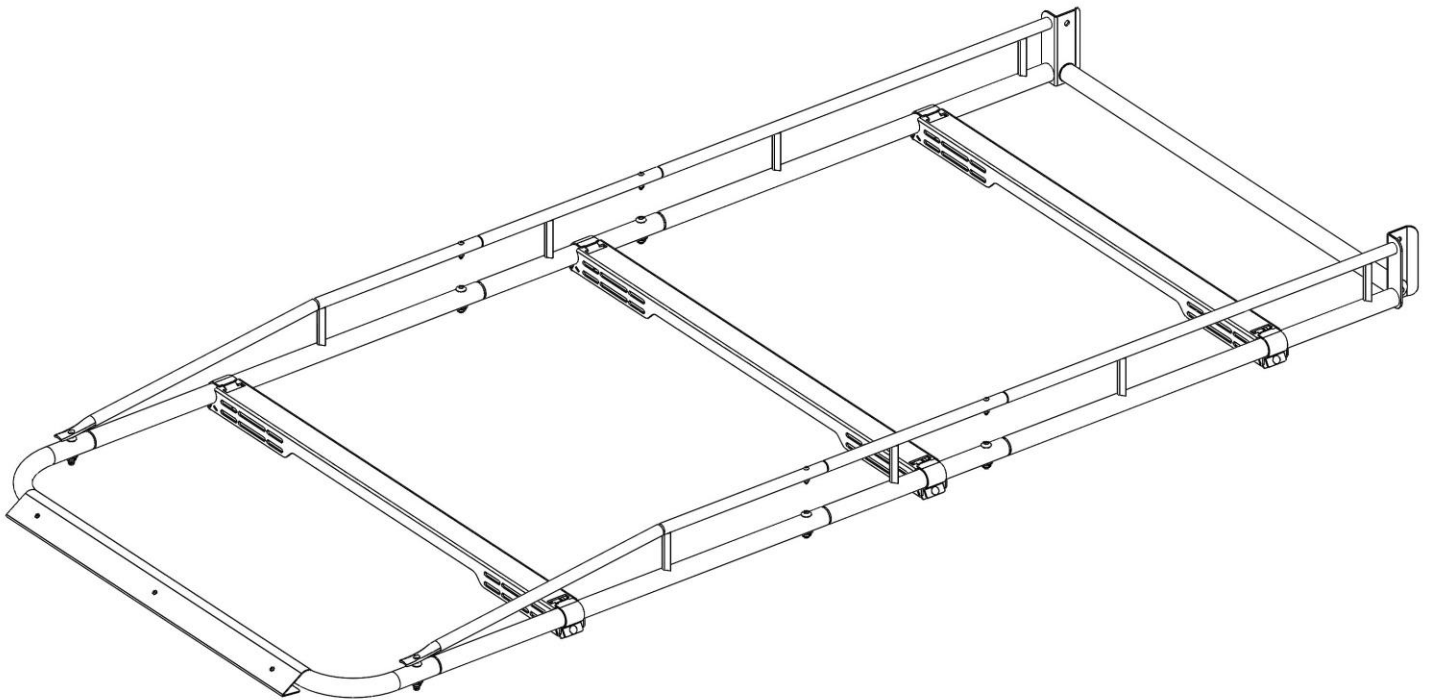

*** PLEASE READ ALL INSTRUCTIONS AND WARNINGS PRIOR TO ASSEMBLING, INSTALLING, AND USING THIS PRODUCT. ***

Warning



DO NOT EXCEED MANUFACTURERS WEIGHT CAPACITY FOR ROOF.

Tools Needed

7/16", 1/2" Socket and Wrench	7/16", 1/2" Box Wrenches
#2 Philips Screwdriver	5/32", 5/16" Allen Hex Wrenches

Table of Contents

Parts 2

Hardware (18-8016A) 2

Hardware (18-8000A-RB)..... 4

Step 1 – Assemble Side Channels 5

Step 2 – Attach Roller Bar to Roller Bar Brackets 5

Step 3 – Attach Wind Deflector to Front Crossbar 6

Step 4 – Install Crossbars To Feet 6

Step 5 – Attach Side Channels to Crossbars 7







Step 6 – Attach Front Crossbar 8

Step 7 – Attach Roller Bar Assembly..... 8

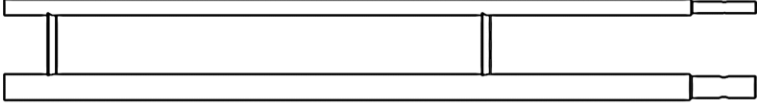
Before You Begin

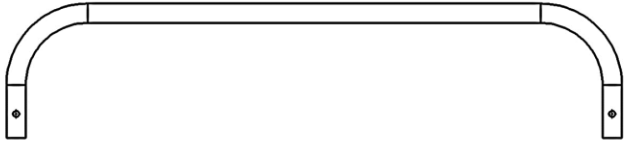
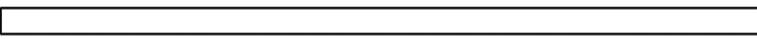
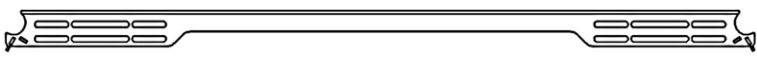
- Read all instructions prior to assembling or installing any Kargo Master product.
- **Always locate your installation locations prior to performing any work.**
- **Be sure to put sealant around all threads entering cargo area and between the rubber spacer and roof of vehicle to prevent water from leaking into cargo area.**
- **HAVE THE MOUNTING KIT INSTALLED TO VEHICLE PRIOR TO INSTALLING THIS RACK.**







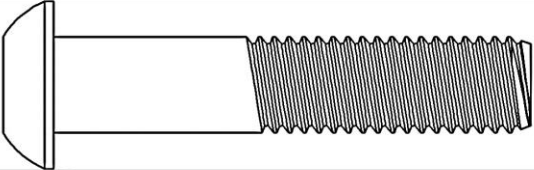
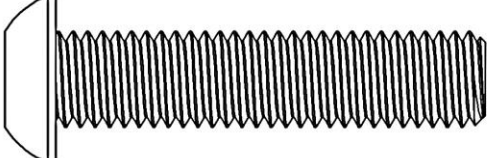

Parts

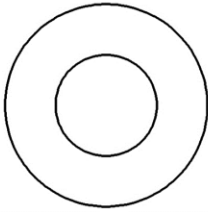
NO.	ITEM	PART NUMBER	DESCRIPTION	QTY.
1		8000A-01	FRONT SIDE CHANNEL	2
2		8000A-03	REAR SIDE CHANNEL	2
3		8000A-04	20" CENTER	2
4		8000A-005	50" FRONT TUBE	1
5		8000A-05	50" ROLLER BAR	1
6		8000A-06	50" CROSSBAR WELDMENT	3
7		8000A-010	SIDE CHANNEL CLAMP	6
8		8000A-019	ROLLER BAR BRACKET, COMPACT VAN	2
9		8000A-016	WIND DEFLECTOR	1
10		8000A-017	WIND DEFLECTOR CLAMP	3
11		18-8016A	ASSEMBLY BOLT KIT	1
12		18-8000A-RB	ROLLER BAR BOLT KIT	1

Hardware (18-8016A)

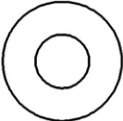
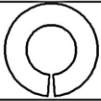
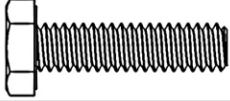
ITEM	HARDWARE TO SCALE	PART NUMBER	DESCRIPTION	QTY.
1			.50 X 2.5" BUTTON HEAD	2
2		24114	1/2"-13 X 2-1/4" BUTTON HEAD	4

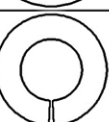
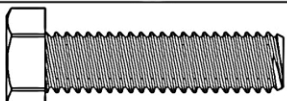
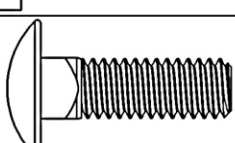
Hardware (18-8016A) (Continued)

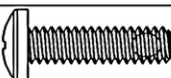
ITEM	HARDWARE TO SCALE	PART NUMBER	DESCRIPTION	QTY.
3		11541086	1/2" WASHER	6
4		37695	1/2"-13 THIN LOCKING JAM NUT	6
5		92949A546	1/4-20 X 1 1/2 BUTTON HEAD	4
6		0167030	1/4"-20 FLANGED LOCK NUT	4
7		33078	1/4" WASHER	2
8		1133618	1/4"-20 LOCK WASHER	2
9		13005	1/4"-20 X 1" HEX HEAD BOLT	2
10		11545144	5/16" FLAT WASHER	2
11		1171067	5/16" LOCKING WASHER	2
12		11138690	5/16-18 X 1-1/4" HEX HEAD BOLT	2
13		21811	5/16"-18 X 1" CARRIAGE BOLT	6
14		11104019	5/16-18 FLANGED NYLOCK NUT	6
15		0149489	10-32 X 3/4" PAN HEAD SCREW	3

Hardware (18-8000A-RB)

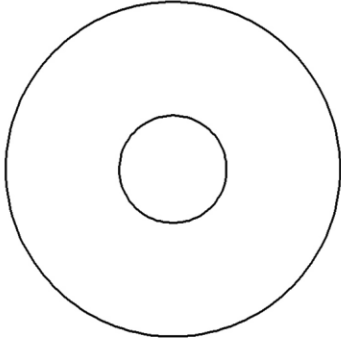
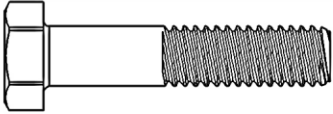
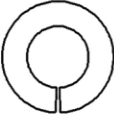
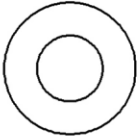
ITEM	HARDWARE TO SCALE	PART NUMBER	DESCRIPTION	QTY.
1		6391K925	5/16" X 9/16" L SLEEVE BEARING	2
2		95611A287	1/2" PLASTIC WASHER, 0.053"- 0.071" THICK	4
3		11241181	5/16"-18 X 1-1/2" HEX HEAD BOLT	2
4		1171067	5/16" LOCKING WASHER	2
5		11545144	5/16" FLAT WASHER	2

DO NOT EXCEED MANUFACTURERS WEIGHT CAPACITY FOR ROOF

Step 1 – Assemble Side Channels

- Push ends of front side channel onto swaged ends of center side channel.

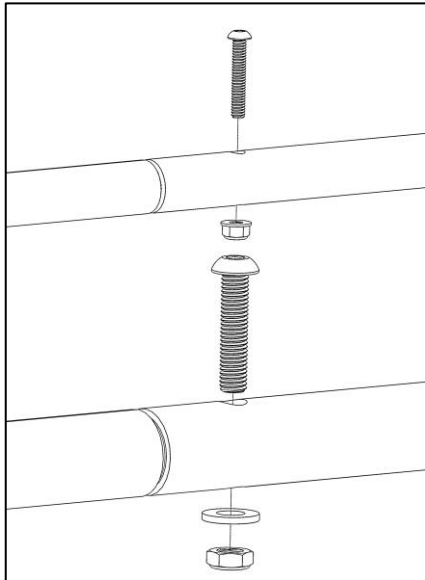
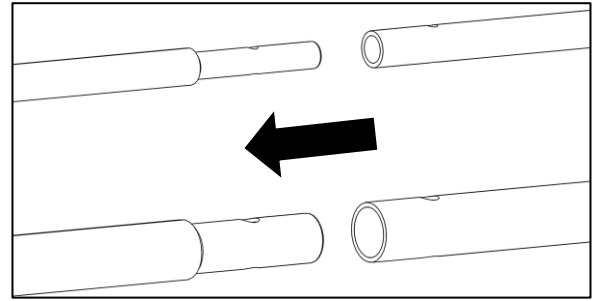

- Using a 1/4" x 1-1/2" button head bolt and 1/4" flanged lock nut, bolt through upper side channel tubes.
- Using a 1/2" x 2-1/4" button head bolt, 1/2" flat washer, and 1/2" locking jam nut, bolt through lower side channel tubes.
- Repeat for rear side channel.

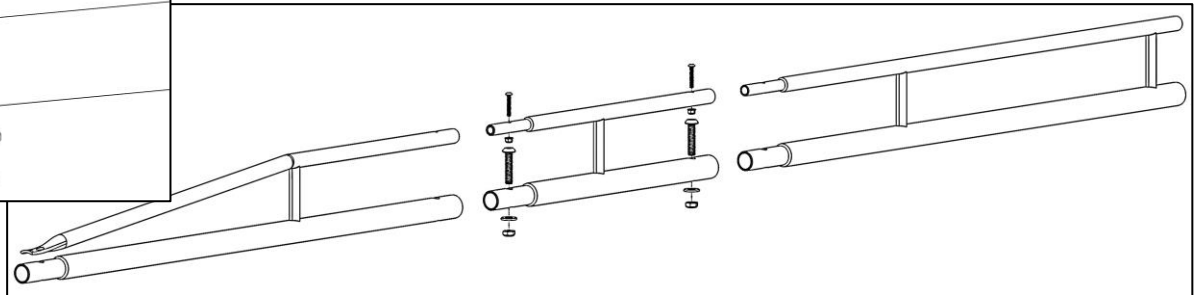

- Repeat for opposite side channel.
- Tighten the bolts going through top and bottom side-channel tubes.

Step 2 – Attach Roller Bar to Roller Bar Brackets

Note: The center roller bar mounting position is best for load bearing. Several positions are provided to accommodate different loading positions.

- Using a 5/16" x 1-1/2" hex head bolt, bolt through the following and into the end of the roller bar.
 - a 5/16" lock washer,
 - a 5/16" flat washer,
 - two plastic washers (one on each side of roller bar bracket),
 - a roller bar bracket, and
 - a roller bearing,

Be sure flanges are facing away from each other and away from center of roller bar.

- Repeat for opposite side.

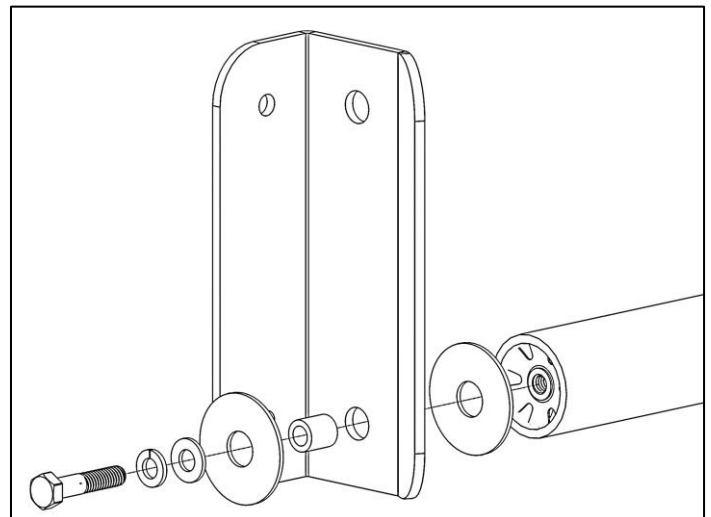

Step 3 – Attach Wind Deflector to Front Crossbar

- Insert wind deflector clamp-retainer into cutout in wind deflector.

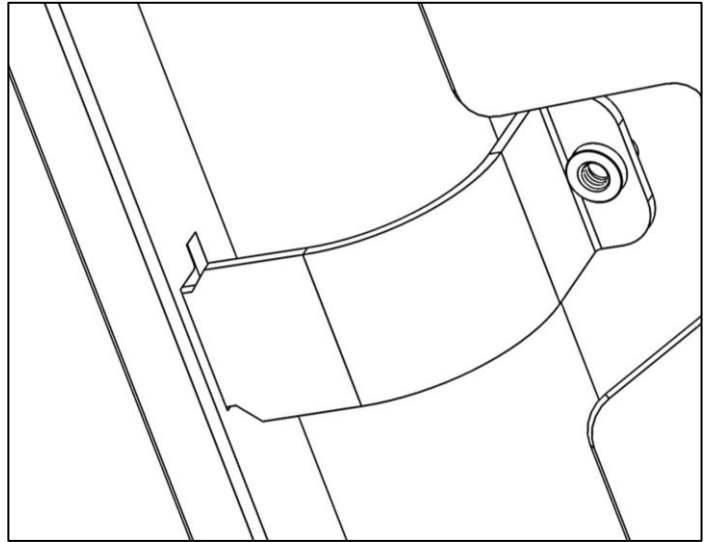
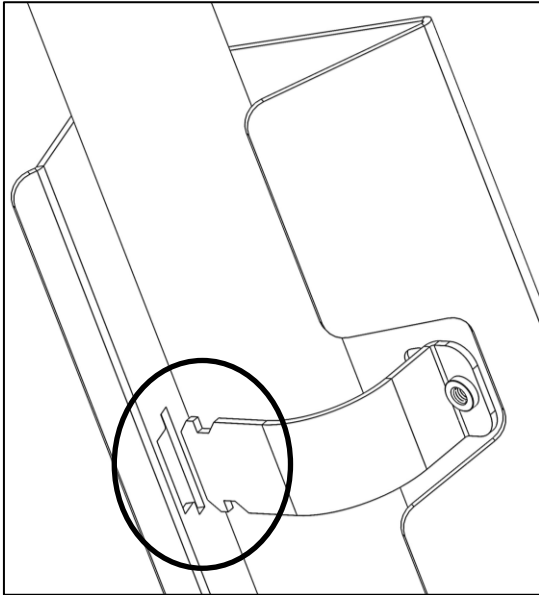

- Hold wind deflector in position with angled edge aimed towards front of vehicle.
- Fasten a #10 x 3/4" pan head screw through the wind deflector into the press nut in the clamp.
- Repeat for remaining two clamps.
- Tighten.

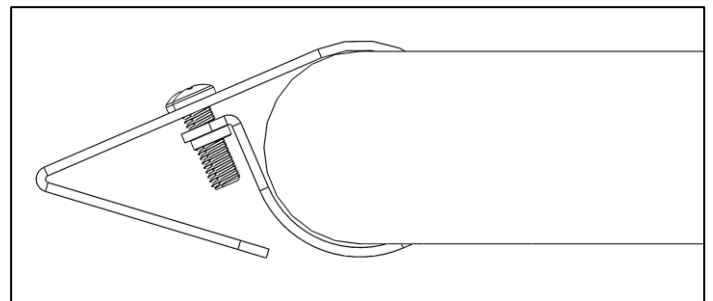

Step 4 – Install Crossbars To Feet

NOTE: Hardware to attach crossbars to feet is included in mounting kit.

- Set crossbar onto feet.
- Center crossbar right-to-left with feet and vehicle.

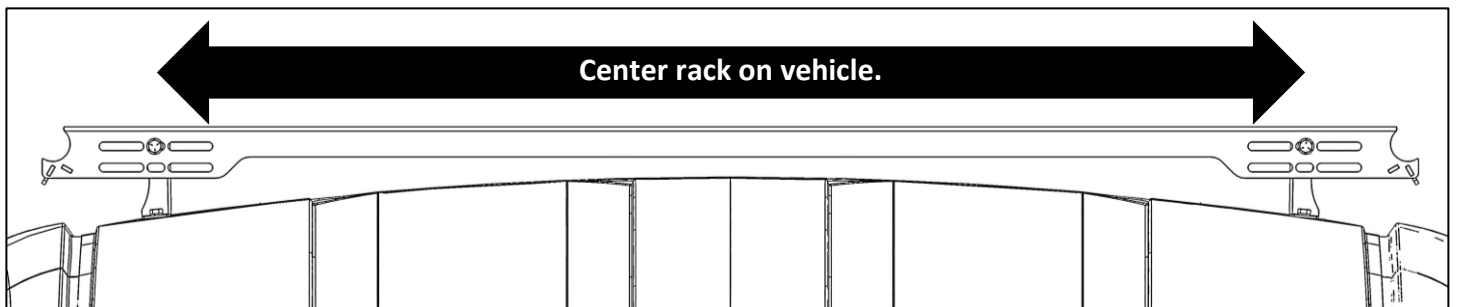

- Using 5/16" x 3/4" hex head bolts, 5/16" lock nuts, and 5/16" flat washers, bolt crossbar to feet.
- Tighten.
- Repeat for all remaining crossbars.

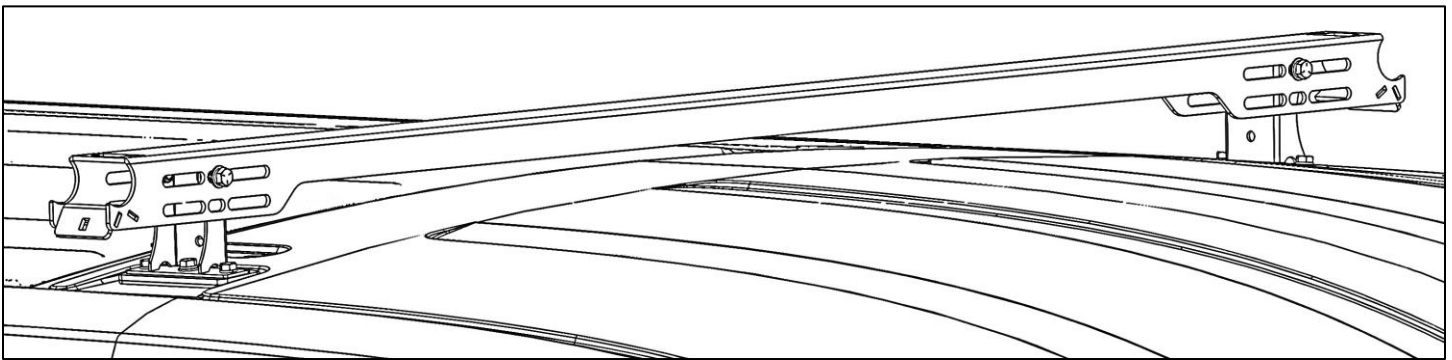
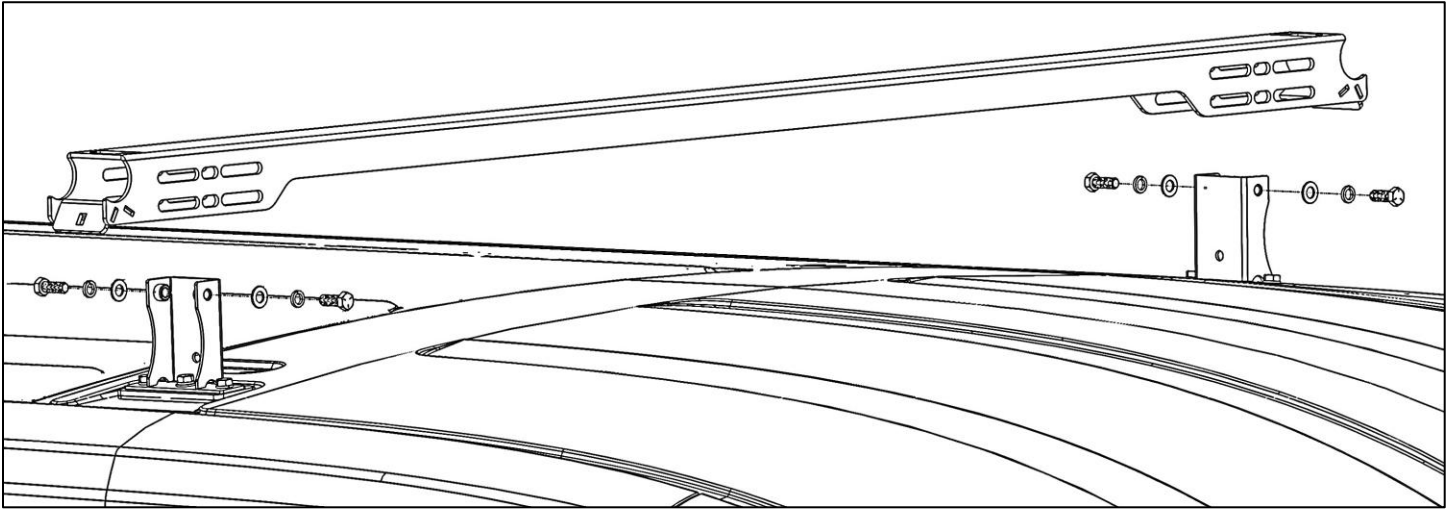

Step 5 – Attach Side Channels to Crossbars

- Set side channel into round cutout in crossbars in desired position.
- Although rack position may be adjusted later, it is recommended to determine the front-to-back position of the rack at this point.
- Insert a side channel clamp into cutout in each crossbar with interior diameter facing upward.

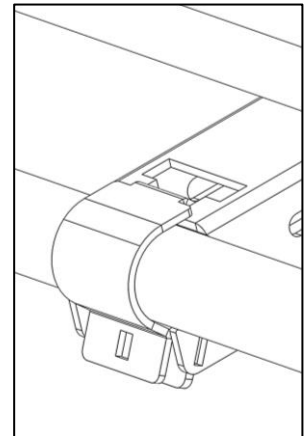
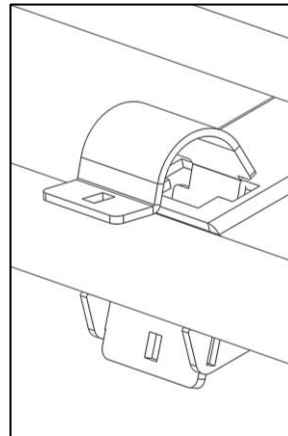
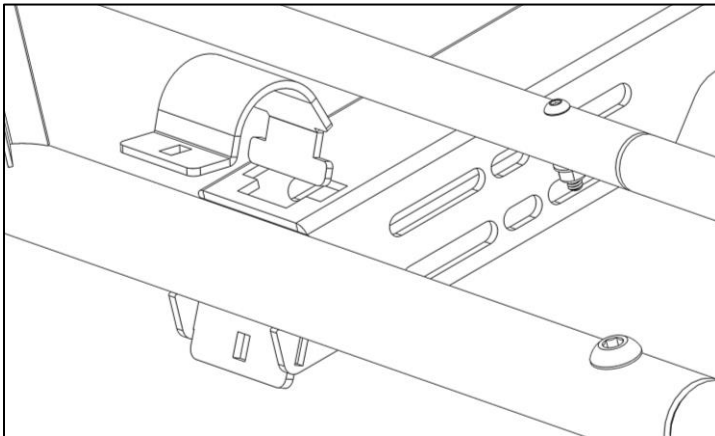

- For each side channel clamp, use a 5/16" x 1" carriage bolt and 5/16" flanged lock nut to bolt side channel clamp to crossbar.
- LOOSELY tighten.

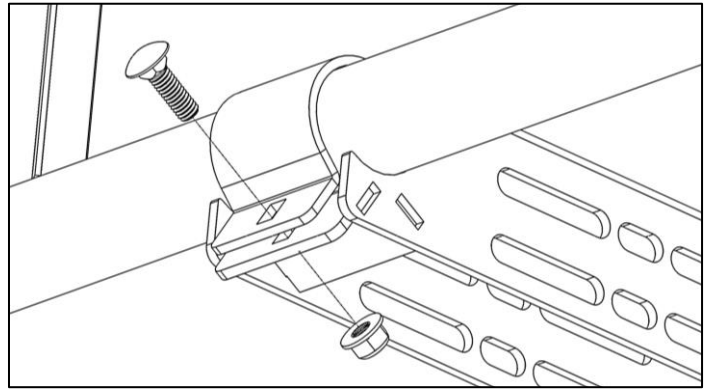

Step 6 – Attach Front Crossbar

- Push front crossbar onto swaged end of front side channel. Be sure to align holes in both and be sure flat face of wind deflector is on top.
- Using a 1/2" x 2-1/2" button head cap screw, 1/2" flat washer, and 1/2" locking jam nut, bolt through front side channel and front crossbar.
- Tighten.
- Repeat for opposite side.

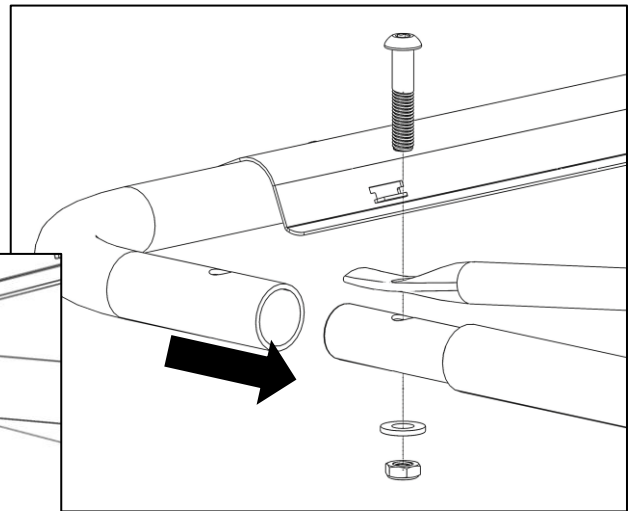
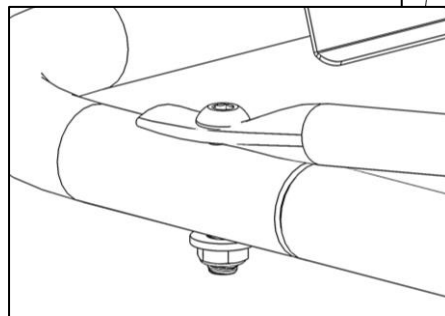

Step 7 – Attach Roller Bar Assembly

- Using a 1/4" x 1" hex head bolt, 1/4" lock washer, and 1/4" flat washer, bolt through a TOP hole in the roller bar bracket into end of the TOP rear side channel.
- Using a 5/16" x 1-1/4" hex head bolt, 5/16" lock washer, and 5/16" flat washer, bolt through the BOTTOM holes in the roller bar bracket into end of BOTTOM rear side channel.
- LOOSELY tighten hardware.
- Repeat for opposite side.

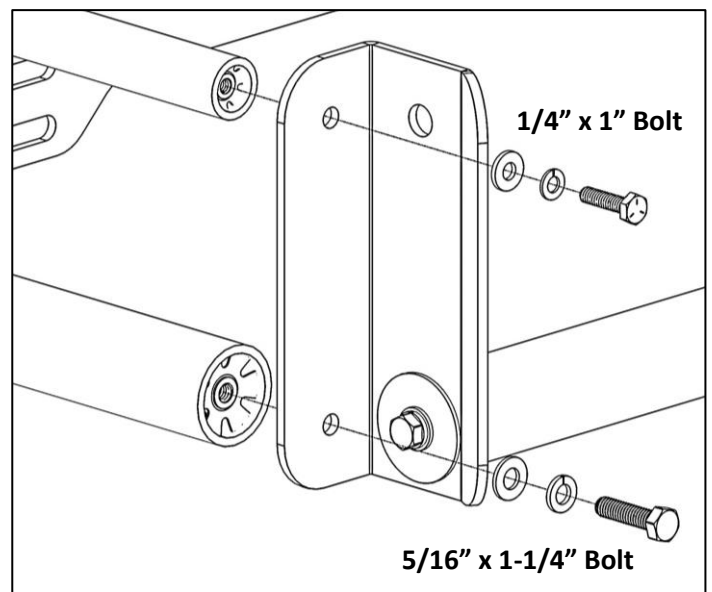

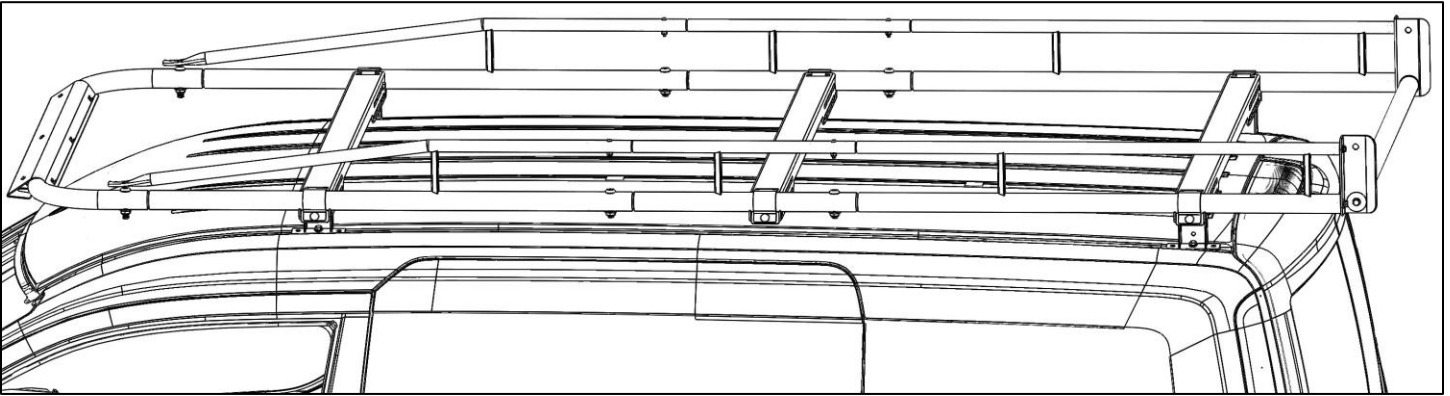

GO BACK AND TIGHTEN ALL HARDWARE.

INSTALLATION AND ASSEMBLY ARE COMPLETE.