

KARGO MASTER®

WE PUT EVERYTHING WITHIN REACH.

Installation Guide

4A82T

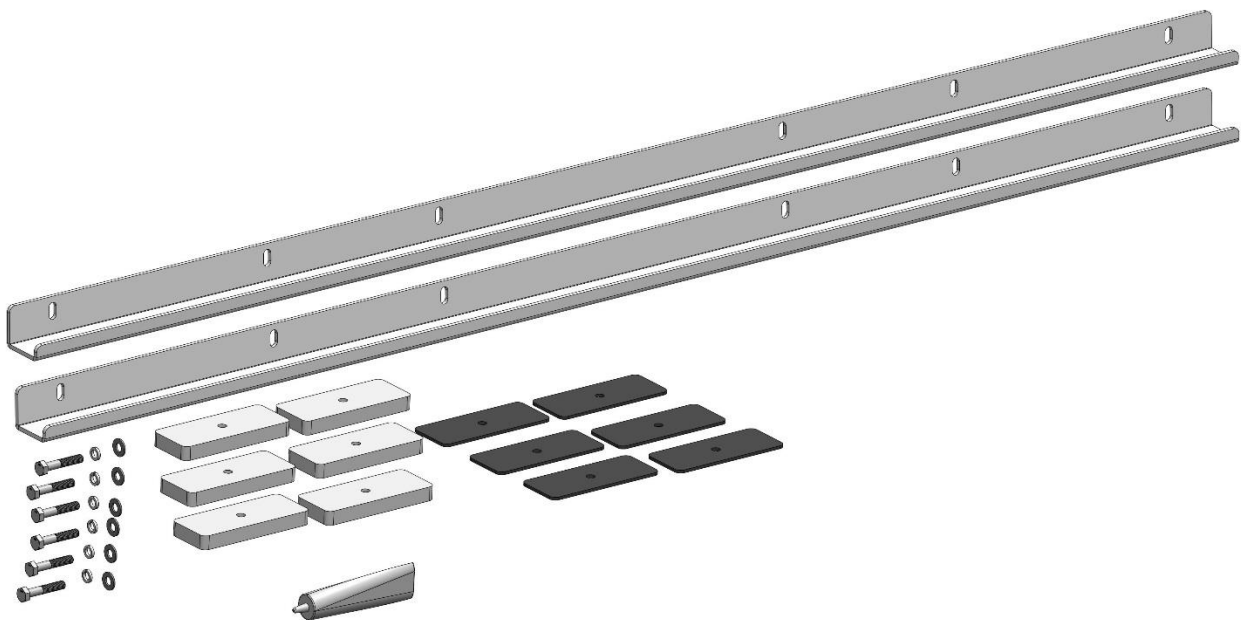

***PLEASE READ ALL INSTRUCTIONS AND WARNINGS PRIOR TO ASSEMBLING,
INSTALLING, AND USING THIS PRODUCT***

Warning



Always check for wires, fuel tanks and lines, brake lines and other important vehicle functionality items prior to drilling and installing all products.

Tools Needed

13mm Wrench and Socket	Measuring Tape



Before You Begin

- Read ALL instructions
 - Follow the ladder rack instructions to install the ladder rack.
 - Be sure to put sealant around exposed threads in roof. Place between the roof and the rubber pad. Put some on the threads of the bolt going into roof.
-

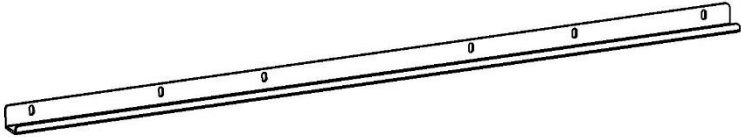
Parts

ITEM NO.		PART NUMBER	DESCRIPTION	QTY.
A		4A820-00-001	RAIL	2
		18-4A82T	HARDWARE KIT	1

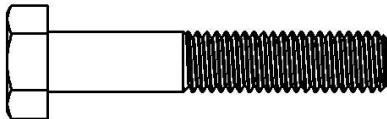
Hardware

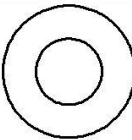
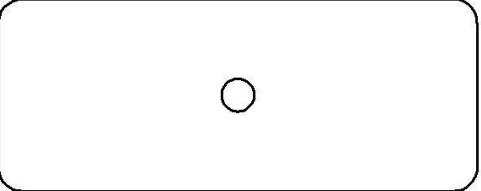
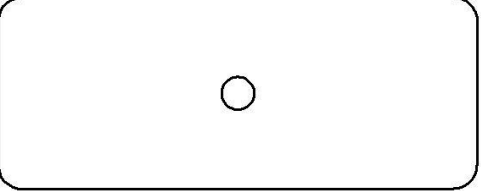
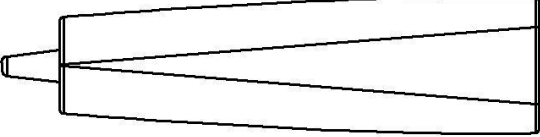
ITEM NO.	TO SCALE	DESCRIPTION	QTY.
1		M8 x 45mm HH	6
2		.312 Split Lock Washer	6
3		.312 Flat Washer	6
4		T249-01 (1:2)	6
5		T249-02 RUBBER (1:2)	6
		BH-821 (SILICONE)	1

Step 1a – 130” Wheel base Rear Mount

- Locate the threaded emboss at the rear of the van. Plugs may need to be removed.

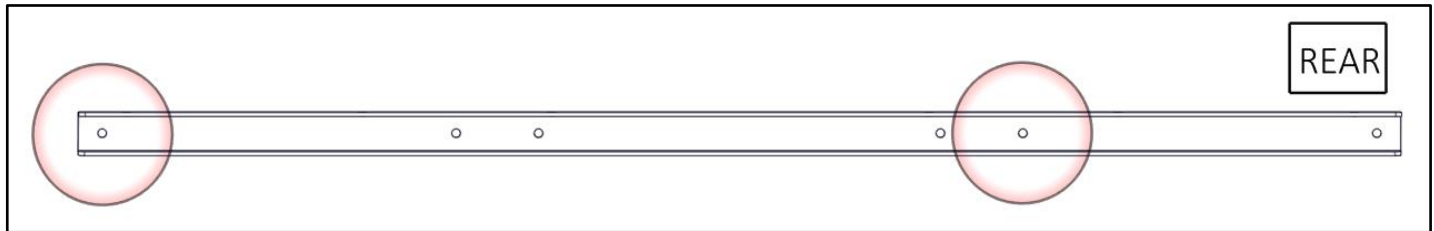
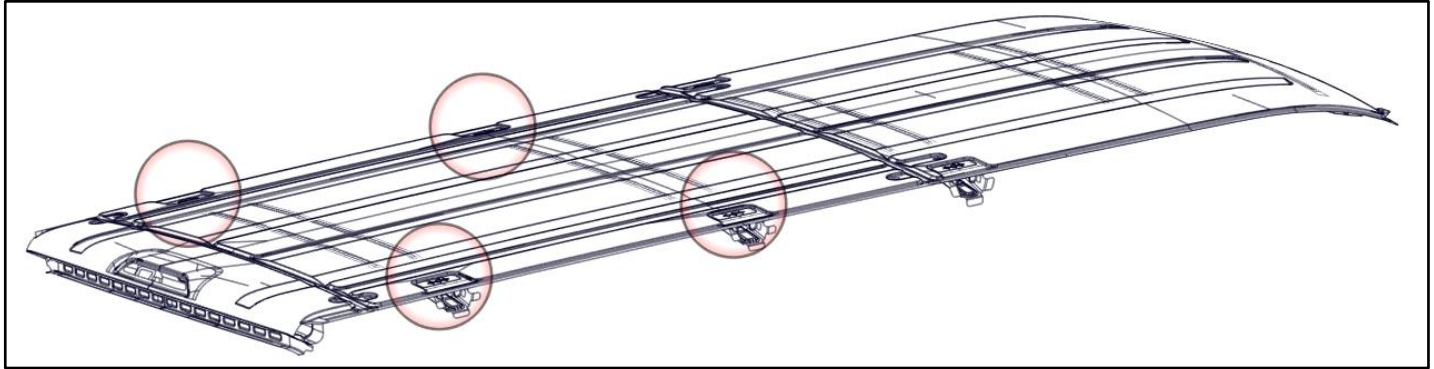

- Place the long mount rail on the roof of the van with the tall flange to the center of the van.
- Bolt through the front most hole in the rail and the corresponding hole at the rear using M8 x 45mm bolts with lock washer and flat washers.
- The rail should be offset to the rear of the van as shown.
- Be sure to put the T-249-01 and rubber pad as shown to comply with the Ford bulletin "Q249". The rubber pad goes against the roof.
- Repeat on driver side.
- Snug tighten, allow movement.

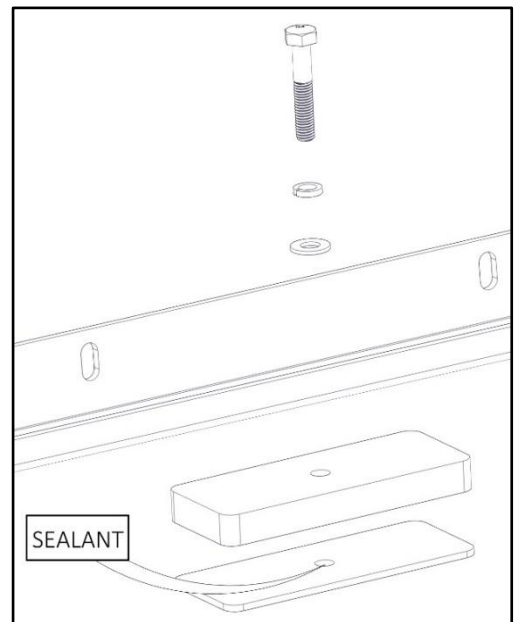

Be sure to place sealant in and around threaded emboss in roof to ensure no water gets into cabin of van.

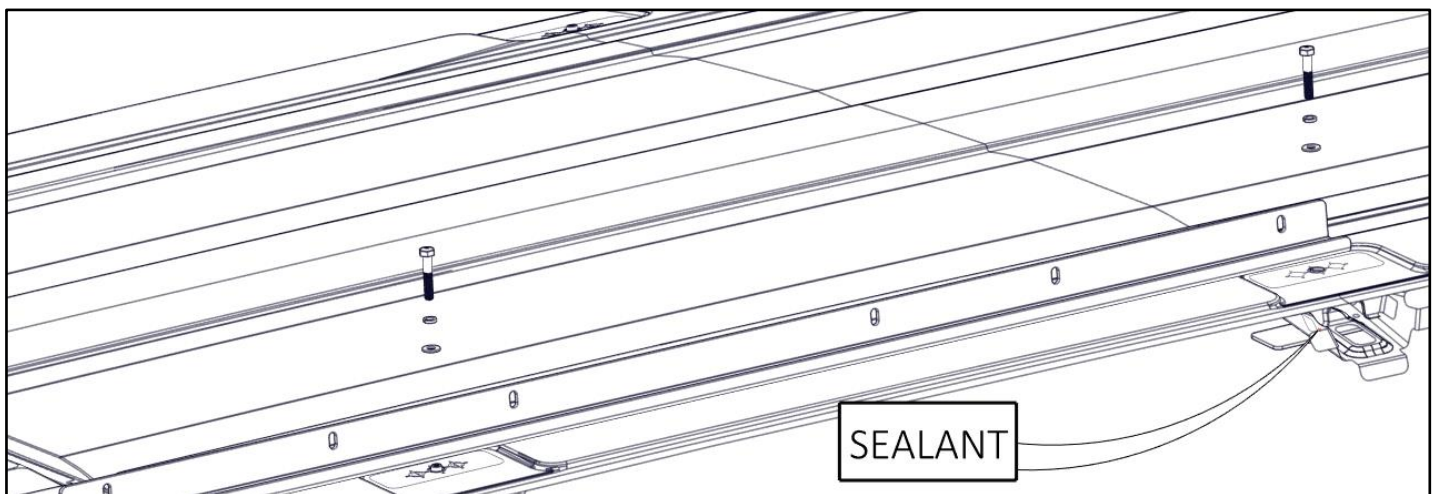

Step 1b – 148" Wheel base Rear Mount

- Locate the threaded emboss at rear of van. Plugs may need to be removed.

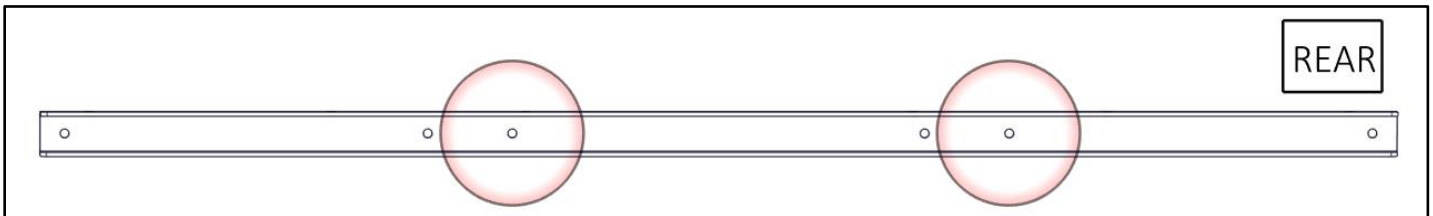
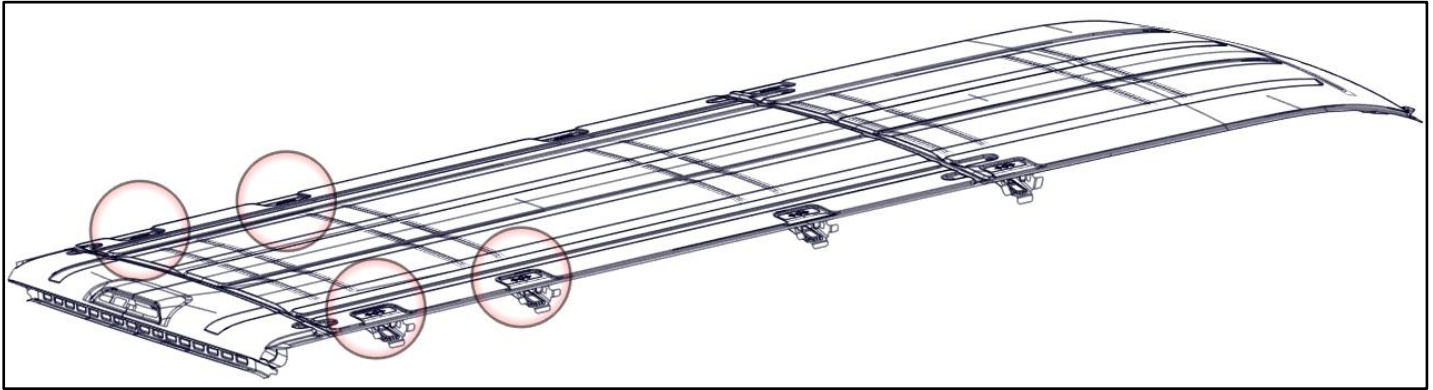

- Place the long mount rail on the roof of the van with the tall flange to the center of the van.
- Bolt through the holes in the rail shown below using M8 x 45mm bolts with lock washer and flat washers.
- The rail should be offset to the rear of the van as shown.
- Be sure to put the T-249-01 and rubber pad as shown to comply with the Ford bulletin "Q249". The rubber pad goes against the roof.
- Repeat on driver side.
- Snug tighten, allow movement.

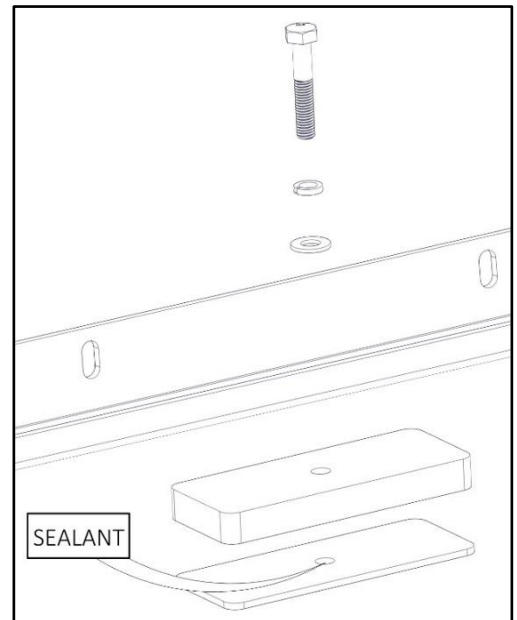

Be sure to place sealant in and around threaded emboss in roof to ensure no water gets into cabin of van

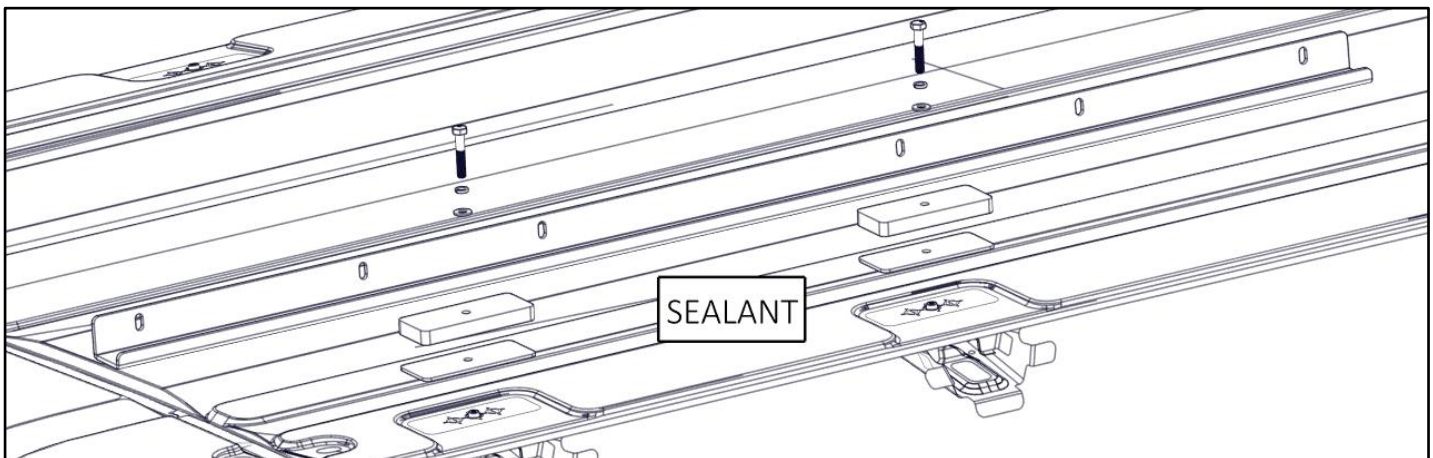

130 WB

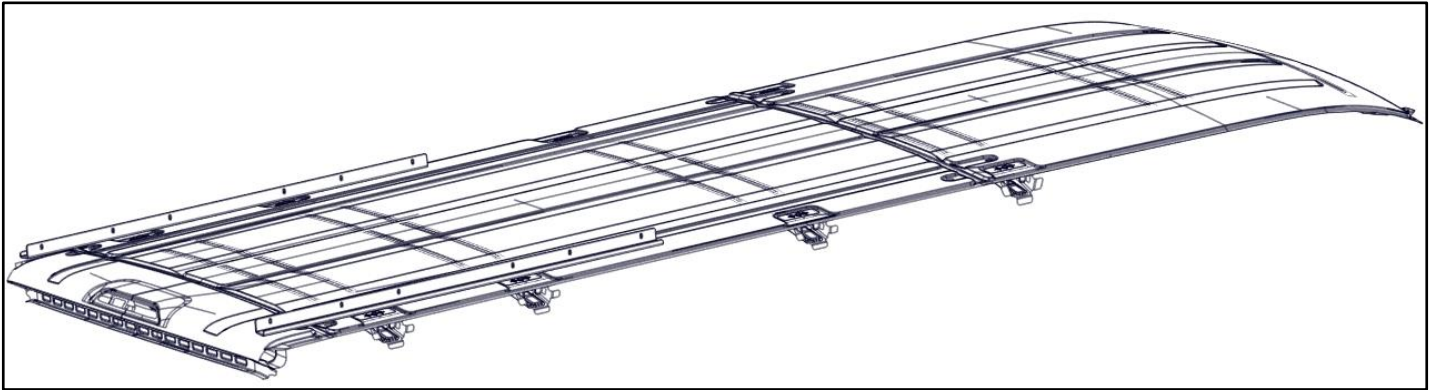

140 WB

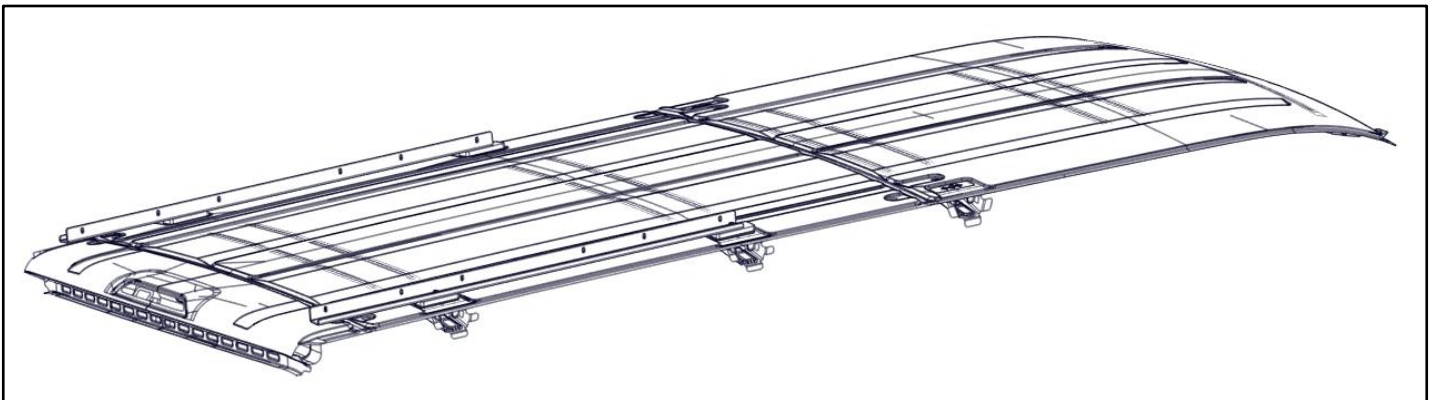

Use instructions included in the ladder rack to complete installation. Once ladder rack is installed on roof, be sure to TIGHTEN the hardware installed in these instructions.

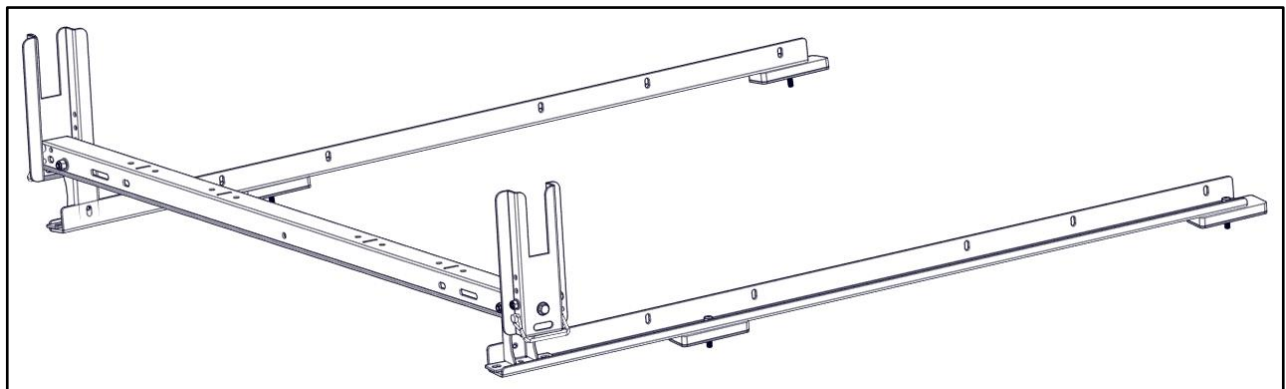

Shown Above, 4A821 installed on 4A82T

KARGO MASTER[®]

WE PUT EVERYTHING WITHIN REACH.

Instruction Guide

40821

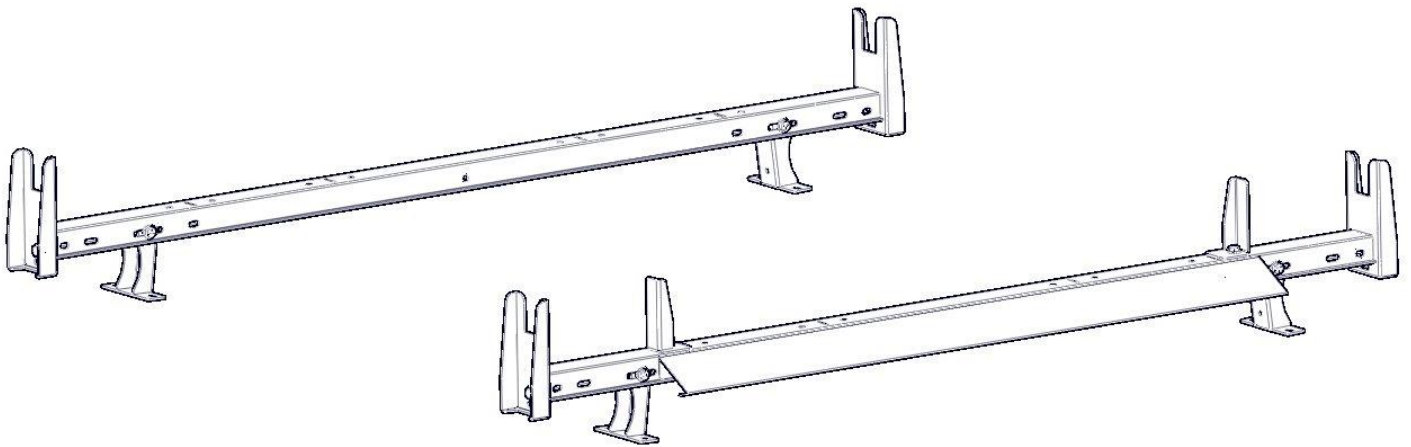

***PLEASE READ ALL INSTRUCTIONS AND WARNINGS PRIOR TO ASSEMBLING,
INSTALLING, AND USING THIS PRODUCT***

Warning



Always check for wires, fuel tanks and lines, brake lines and other important vehicle functionality items prior to drilling and installing all products.

Tools Needed

13mm Socket and Wrench	10mm Socket and Wrench
9/16" Socket and Wrench	

Before You Begin

- Read all instructions.
 - Be sure to put E6000 sealant around all threads entering cargo area and between the rubber spacer and roof of vehicle to prevent water from leaking into cargo area.
-

Parts

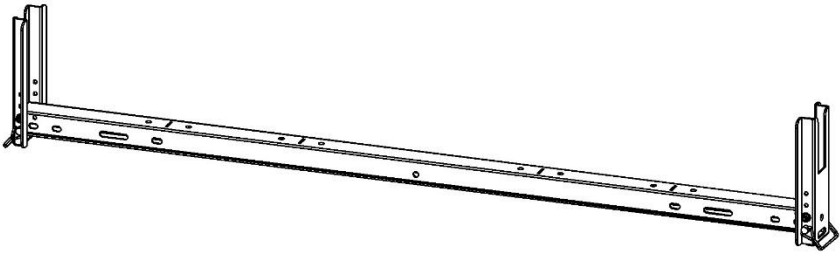
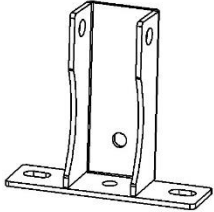
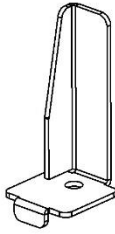
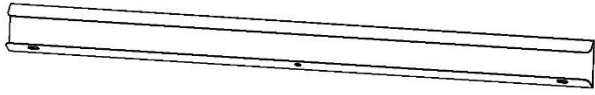
ITEM NO.		PART NUMBER	QTY.
A		4A821-10	2
B		4A821-10-001	4
C		4A821-10-006	2
D		4A821-10-009	1

Assembly Hardware (18-40821-A)

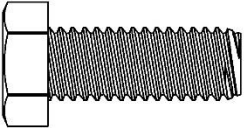
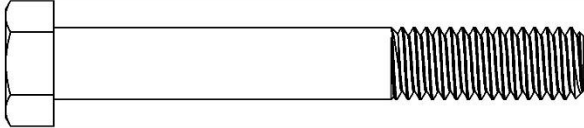
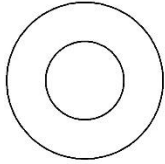
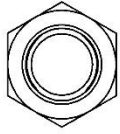
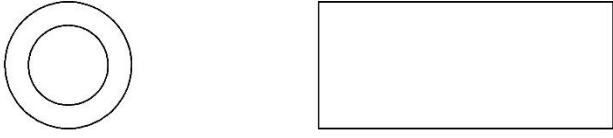
ITEM NO.	18-40821-A TO SCALE	DESCRIPTION	PART NUMBER	QTY.
1		.375-16 x 1 HH	92865A622	9
2		.375-16 x 2.75 HH	91247A635	4
3		.375 Flat Washer	90126A031	26
4		.375-16 Nyloc	95615A140	13
5		40821-10-005-R1	11-00396	4

Step 1 – Assemble Ladder Hooks

- On one cross member (A), bolt two ladder hooks (C) to the top of cross member using one 3/8 x 1 hex head (1) two 3/8 flat washers (3) and one 3/8 nyloc (4).
- The tab on the ladder hook will line up with the slot in the crossmember.
- Typically, this cross member goes to the front of the vehicle.
- TIGHTEN

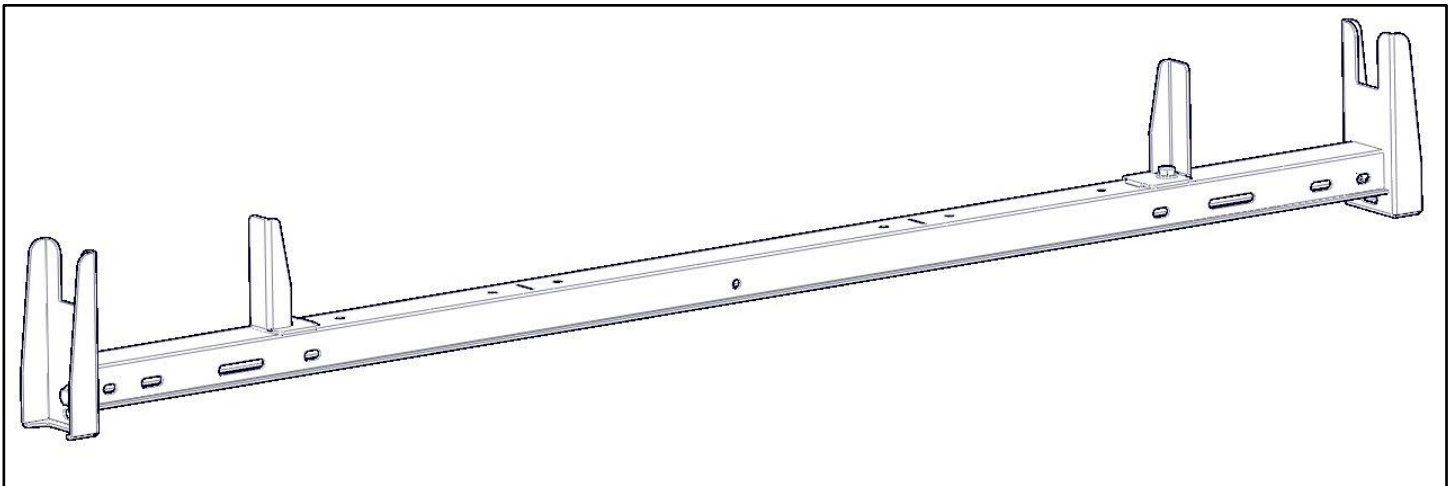
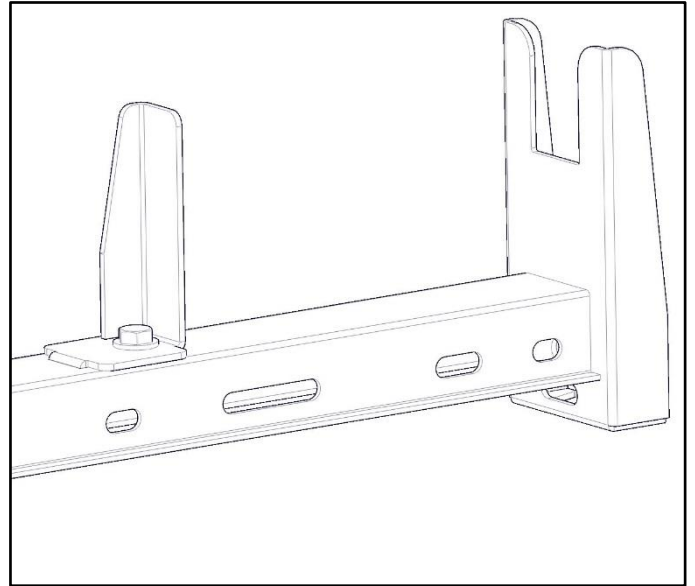
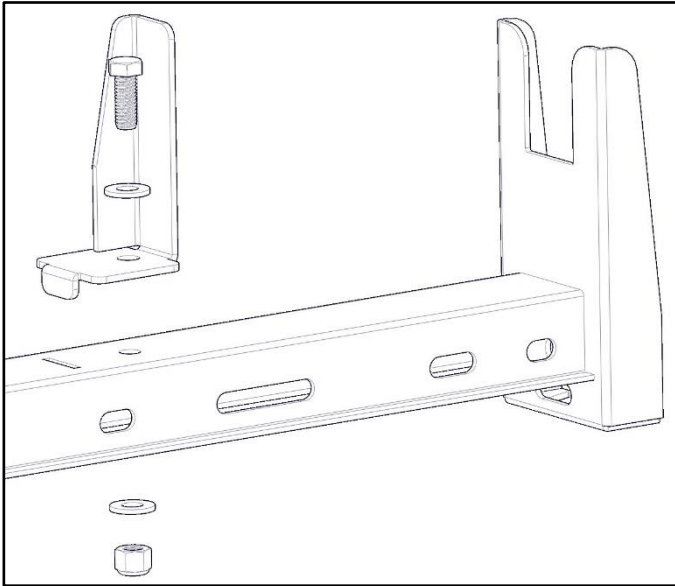

Step 2 – Assemble Wind Deflector

- Bolt wind deflector (D) to the front of the cross member (A) through the slot as shown below.
Typically this is attached to the same cross member with the ladder hooks
- Use a 3/8 x 1 hex head bolt (2), a 3/8 flat washer (3) and a 3/8 nyloc nut (4) in the order shown.
- Repeat in other two locations as shown.

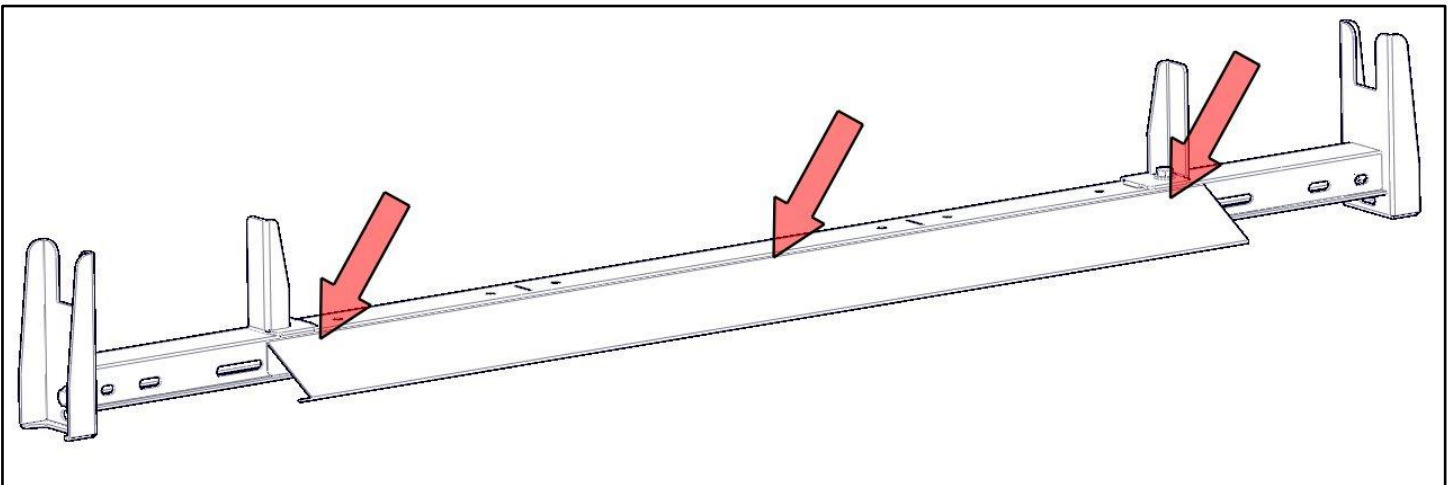
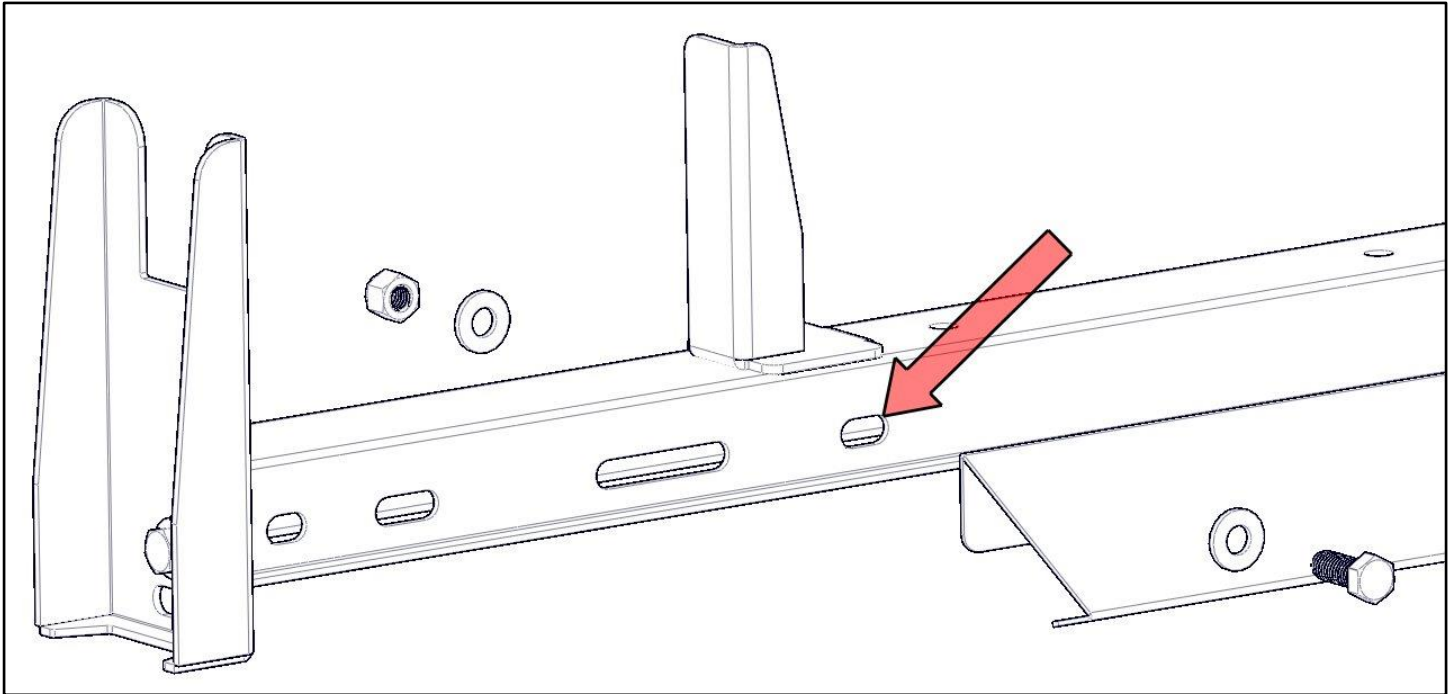

- Square and TIGHTEN

Step 3 – Assembly of Foot

- Depending on your vehicle, the foot will mount in different slots.

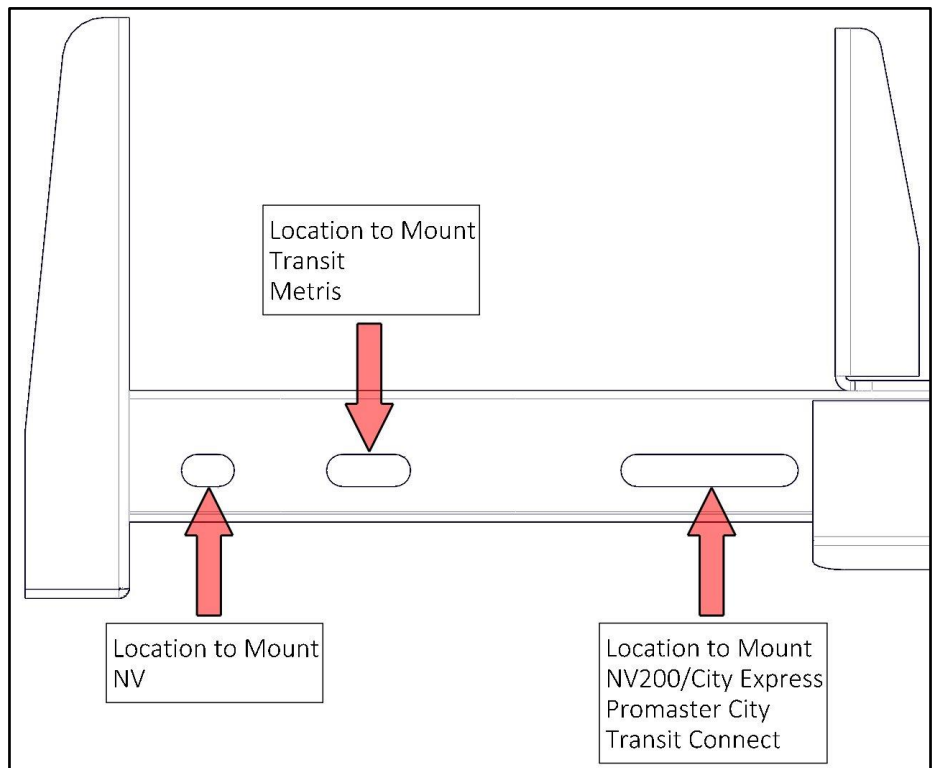

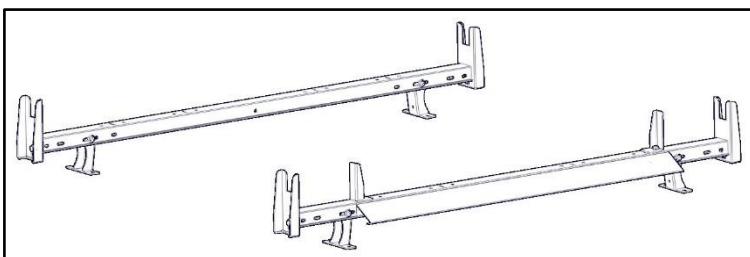
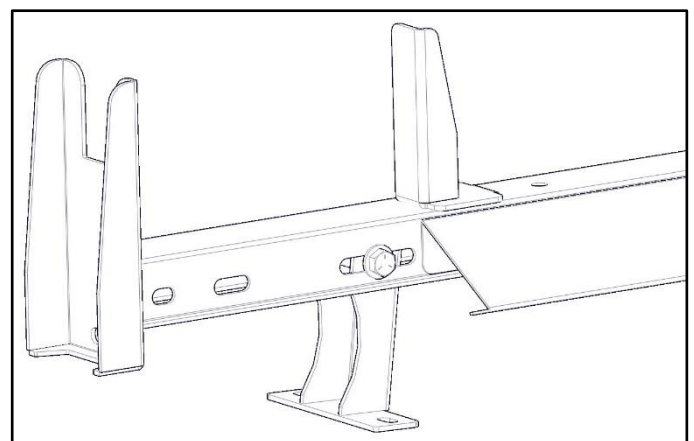
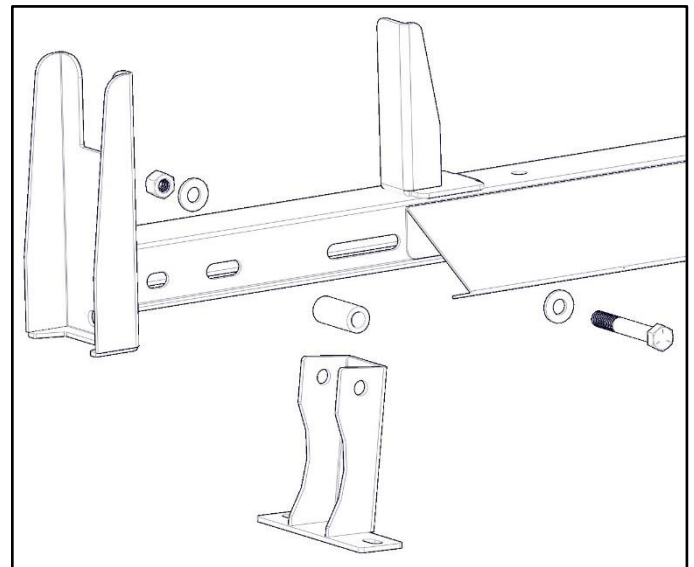

- Use a 3/8 x 2.75 hex head bolt (2), two 3/8 flat washers (3) and a 3/8 nyloc nut (4) to bolt foot(B) to crossmember (A). Be sure to insert the nylon spacer (5) inside foot.
- Have the cup in the foot facing outward. (as shown)
- Repeat on both sides and both crossmembers
- Do NOT tighten.



Installation Instructions

Find vehicle below, follow instructions from there.

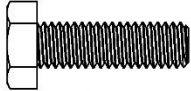
Installation Hardware (To Scale) (18-40821-M)

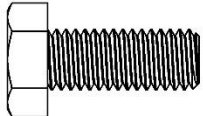
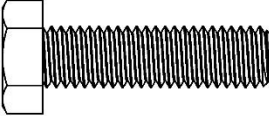
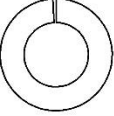
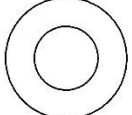
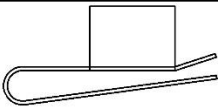
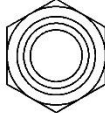
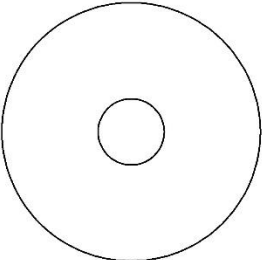
ITEM NO.	18-40821-M		PART NUMBER	QTY.
6		M6x1 x 20mm HH	91280A330	8
7		M6 Split Lock Washer	91202A234	8
8		M6 Flat Washer	91166A250	8
9		M8x1.25 x 20mm HH	91280A530	8
10		M8x1.25 x 30mm HH	91280A538	4
11		M8 Split Lock Washer	91202A238	8
12		M8 Flat Washer	91166A270	8
13		M8 U-Nut	95210A190	8
14		M8x1.25 Nyloc	90576A117	4
15		.312 Fender Washer	.312 Fender Washer	4

Installation Hardware (con't)

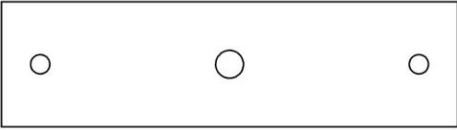
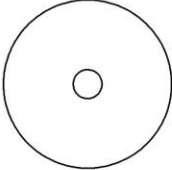
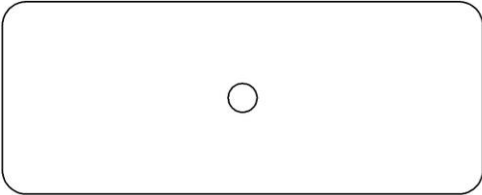
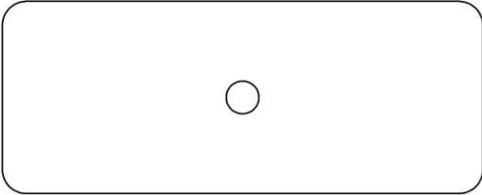
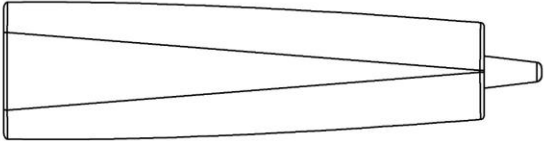
ITEM NO.	18-40821-M		PART NUMBER	QTY.
16		40821-10-004-R1	40821-10-004-R1	4
17		.125x.312x1.75 Rubber Washer	.125x.312x1.75 Rubber Washer	4
18		T249-02-R1	RUBBER	4
19		T250-01	Transit Steel Plate	4
		E6000	E6000	1

Transit Connect

Step 1

- Remove plugs from desired mounting location in the roof of van.

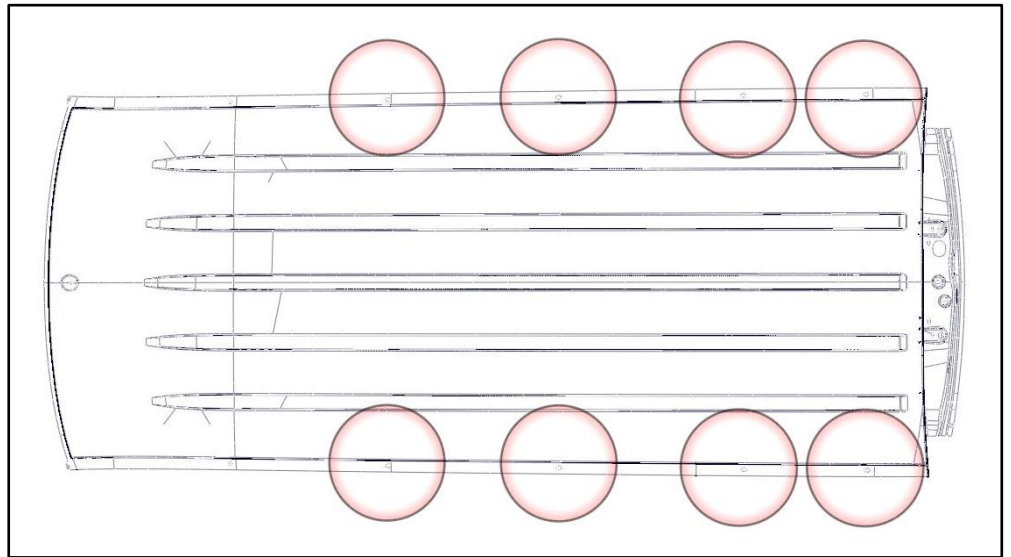

Step 2

- Bolt through the mount foot (B) into the exposed holes in roof using one M8 x 30mm hex head (10), one M8 flat washer (12), a rubber spacer (16), a rubber washer (17), one fender washer (15) another M8 flat washer (12) and one M8 nyloc (10). In the order shown.
- Be sure to put rubber spacer (16) in between mount foot (B) and roof of van as shown below.
- The roof goes in between rubber spacer (16) and rubber washer (17)
- Place E6000 between rubber spacer and roof of van and around threads to ensure no water leaks into van.

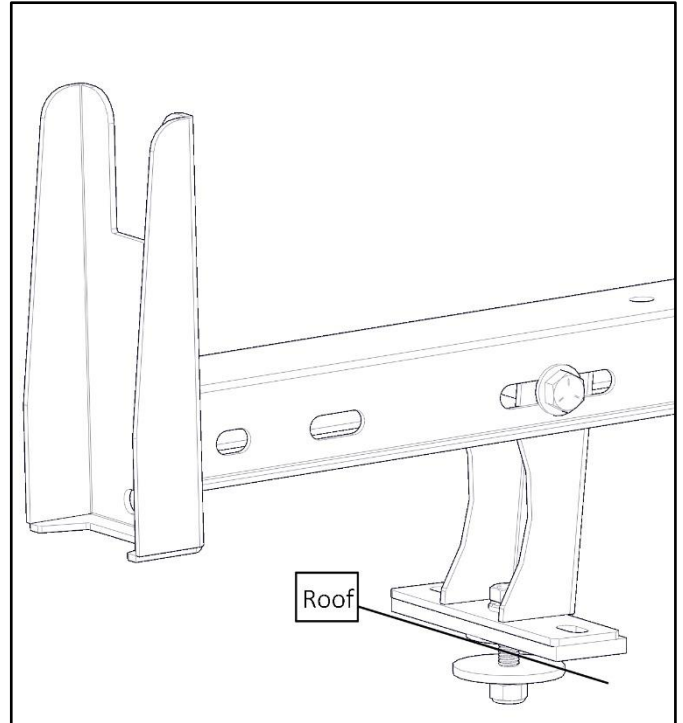
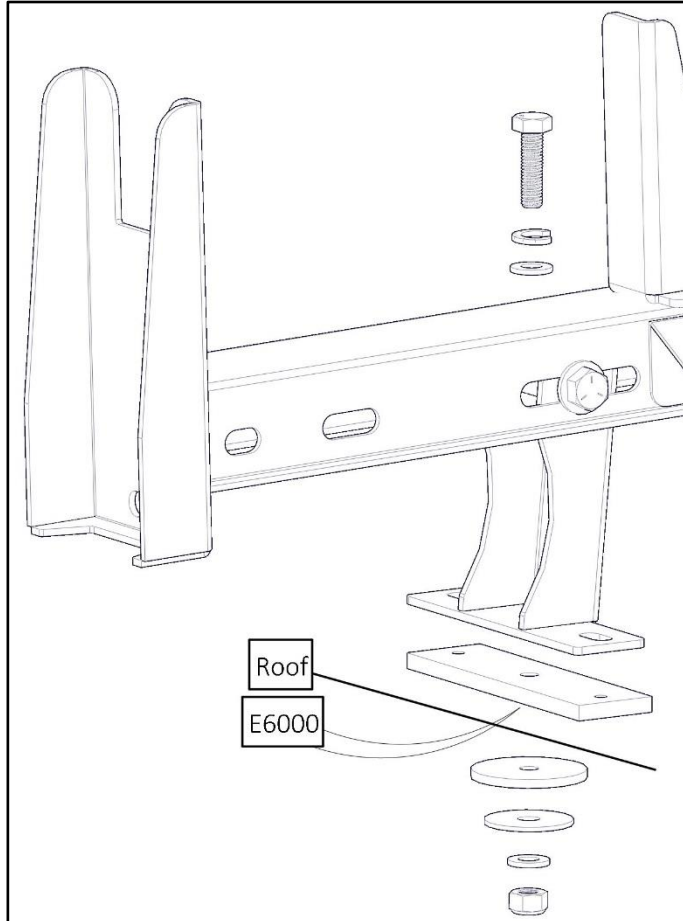

Step 3

- Go back and tighten all bolts including nuts and bolts on the rack itself.

Transit

Step 1 -

- Remove plugs from desired mounting location in the roof of van.

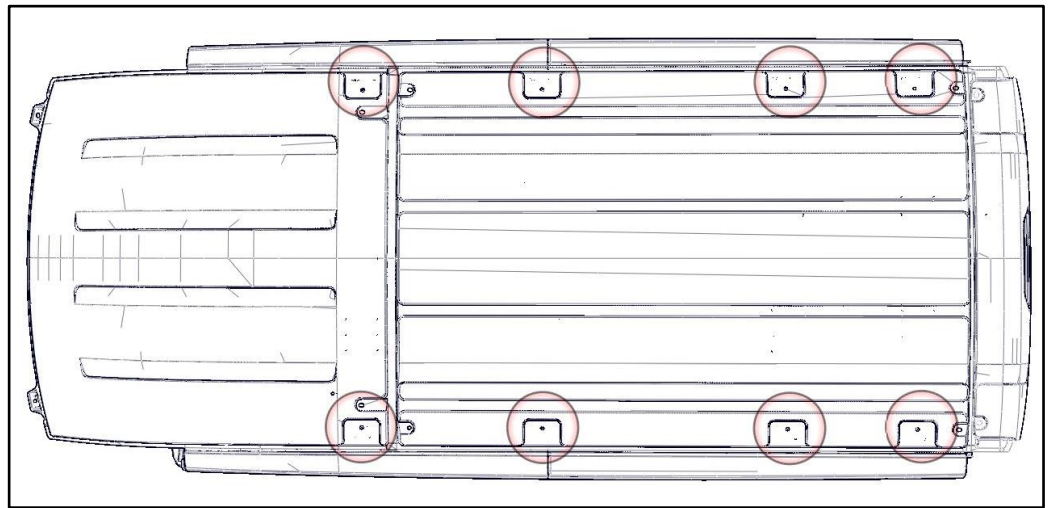

Step 2

- Bolt through the mount foot (B) into the exposed holes in roof using one M8 x 30mm hex head (10), one M8 lock washer (11), one M8 flat washer (12), a metal plate (19) and a rubber pad (18). In the order shown.
- Be sure to put rubber pad (18) and metal plate (19) in between mount foot (B) and roof of van as shown below. The rubber pad goes on the roof.
- Place E6000 between rubber pad and roof of van and around threads to ensure no water leaks into van.

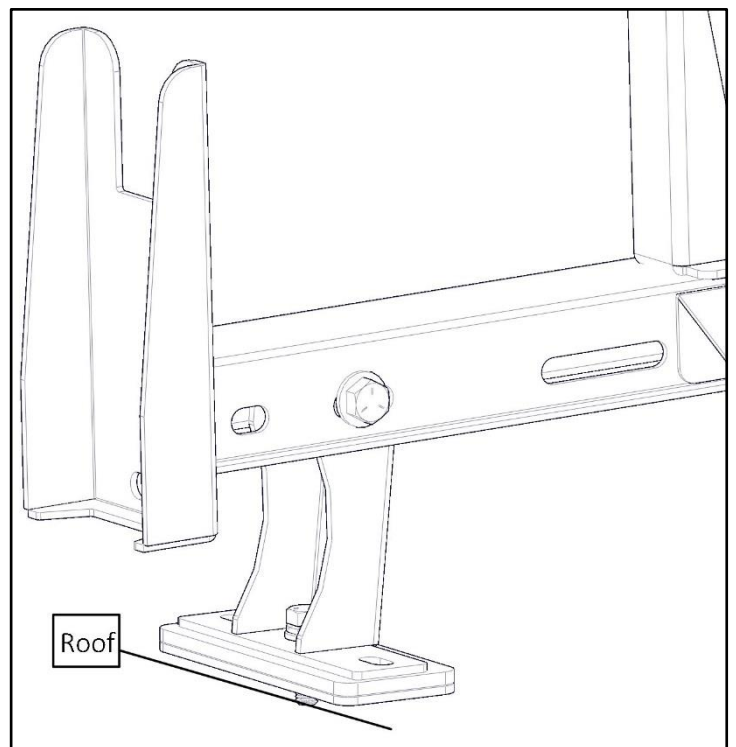
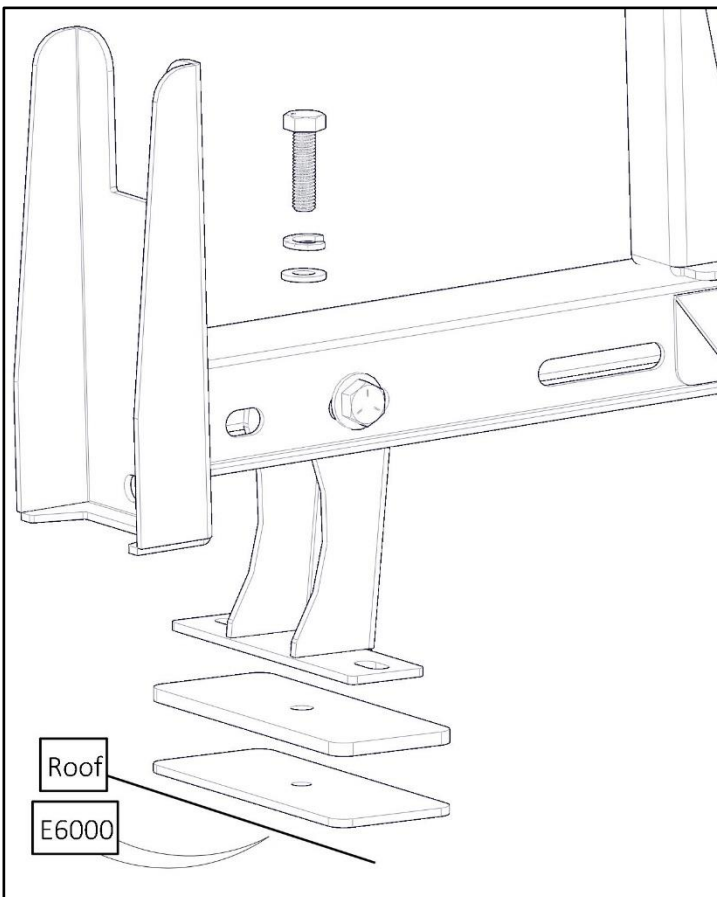

Step 3

Go back and tighten all bolts including nuts and bolts on the rack itself.

Promaster City

Step 1

- Remove plugs from desired mounting location in the roof of van.

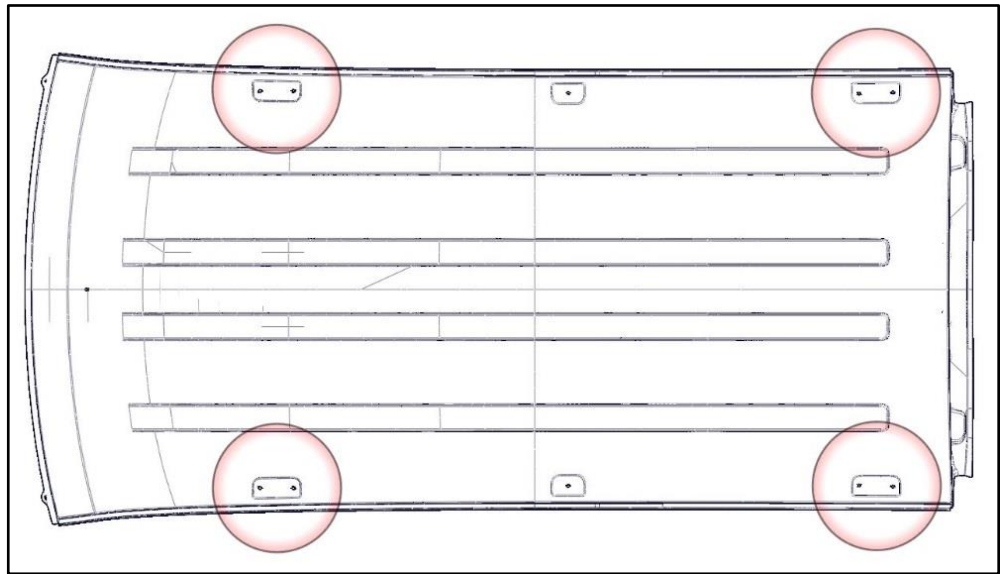

Step 2

- Bolt through the mount foot (B) into the exposed holes in roof using one M6 x 20mm hex head (6), one M6 lock washer (7), one M6 flat washer (8) and a rubber spacer (16). In the order shown.
- Be sure to put rubber spacer (16) in between mount foot (B) and roof of van as shown below.
- Place E6000 between rubber spacer and roof of van and around threads to ensure no water leaks into van.

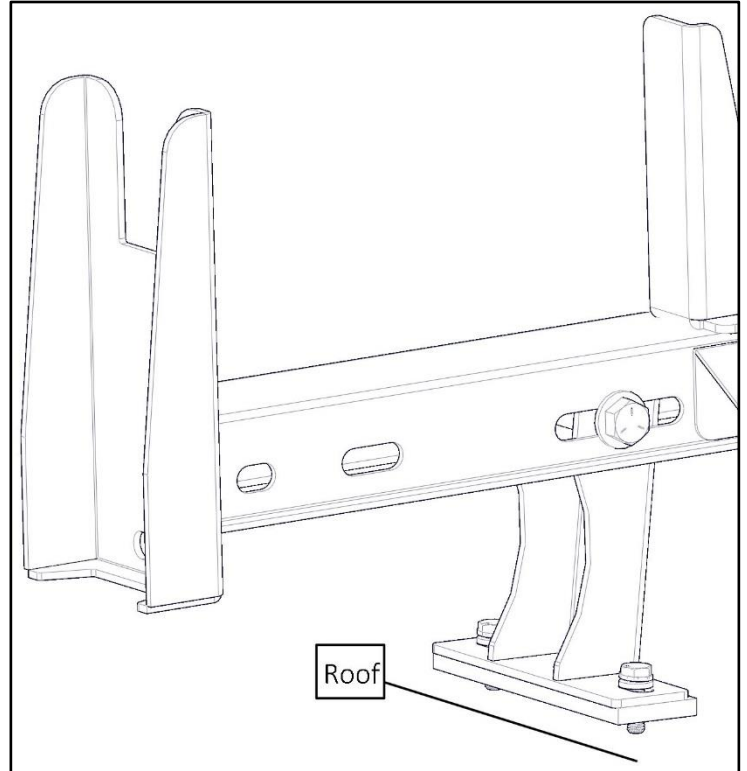
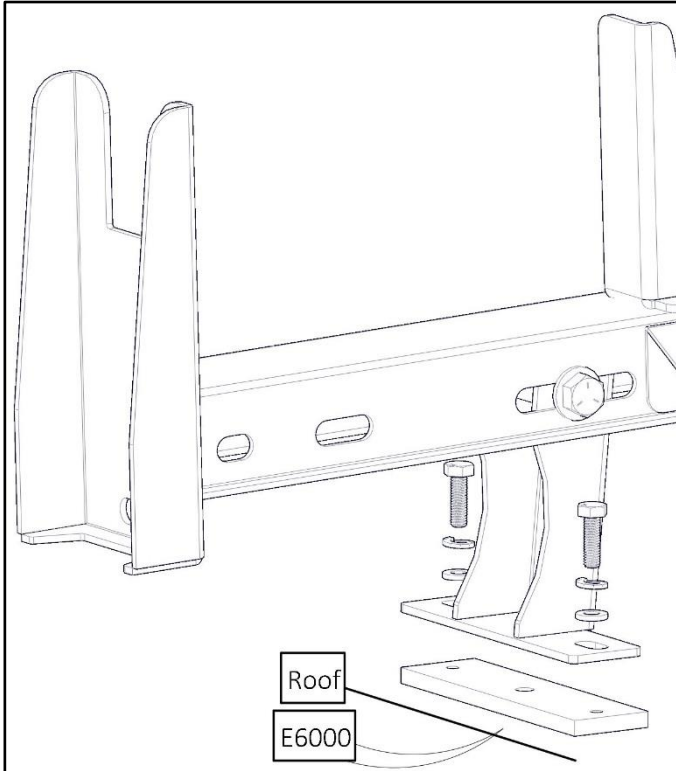

Step 3

- Go back and tighten all bolts including nuts and bolts on the rack itself.

NV200/Chevy City Express

Step 1

- Remove plugs from desired mounting location in the roof of van.

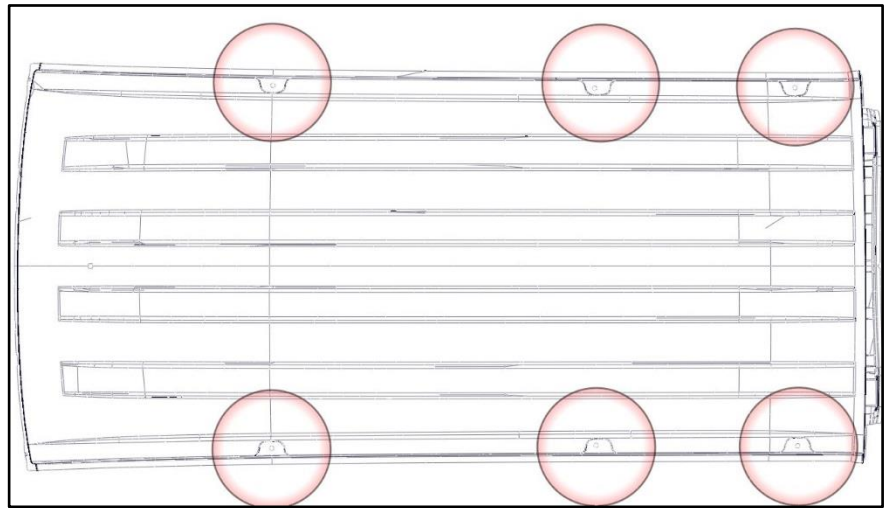

Step 2

- Bolt through the mount foot (B) into the exposed holes in roof using one M8 x 30mm hex head (10), one M8 lock washer (11), one M8 flat washer (12) and a rubber washer (17). In the order shown.
- Be sure to put rubber washer (17) in between mount foot (B) and roof of van as shown below.
- Place E6000 between rubber spacer and roof of van and around threads to ensure no water leaks into van.

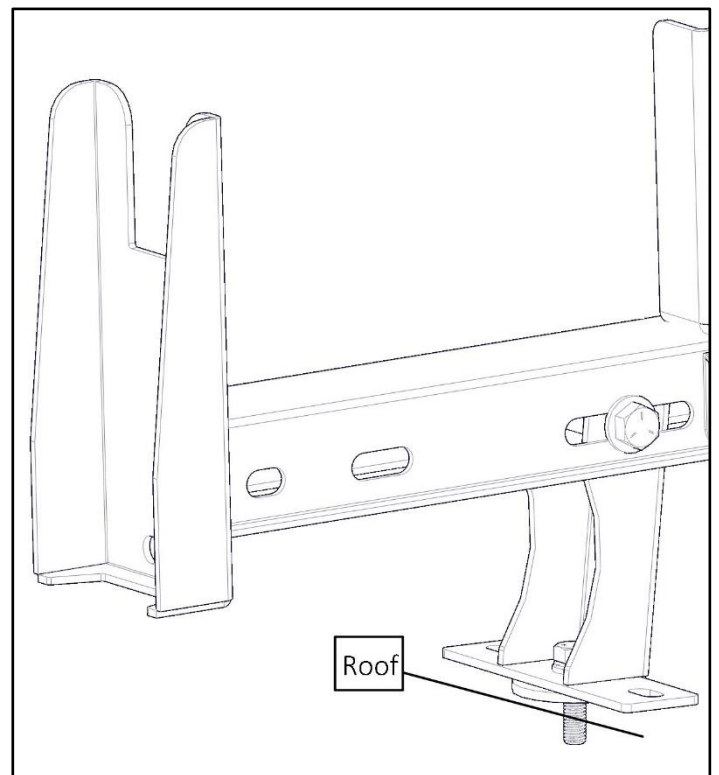
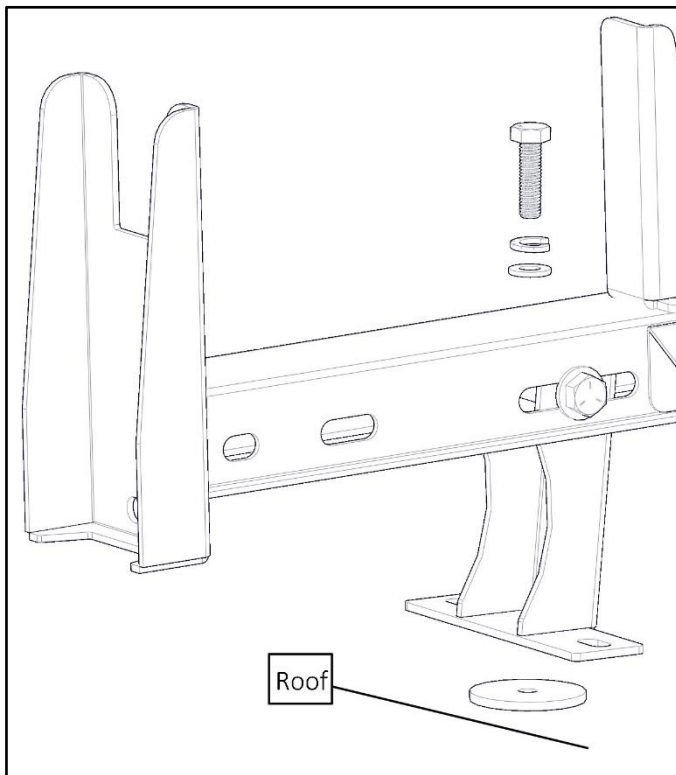

Step 3

- Go back and tighten all bolts including nuts and bolts on the rack itself.

Metris

Step 1

- Remove plugs from desired mounting location in the roof of van.

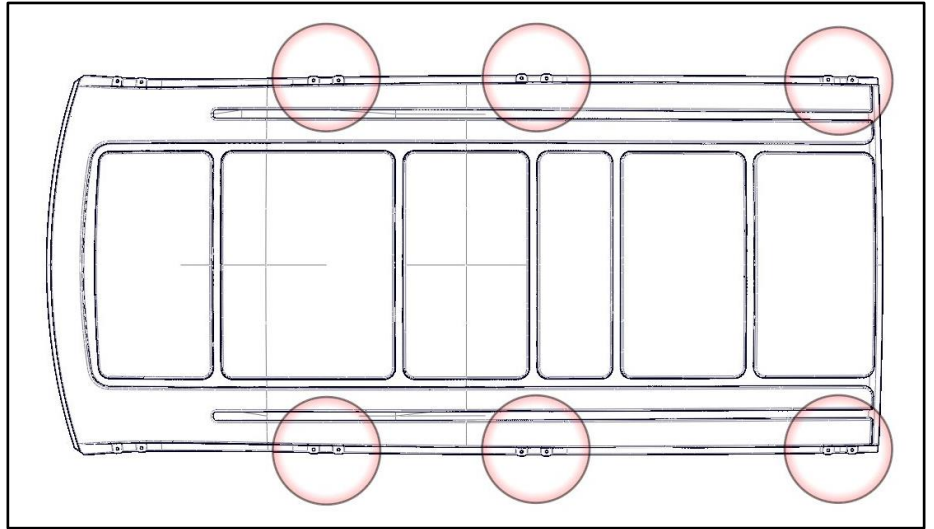

Step 2

- Bolt through the mount foot (B) into the exposed holes in roof using one M6 x 20mm hex head (6), one M6 lock washer (7), one M6 flat washer (8) and a rubber spacer (16). In the order shown.
- Be sure to put rubber spacer (16) in between mount foot (B) and roof of van as shown below.
- Place E6000 between rubber spacer and roof of van and around threads to ensure no water leaks into van.

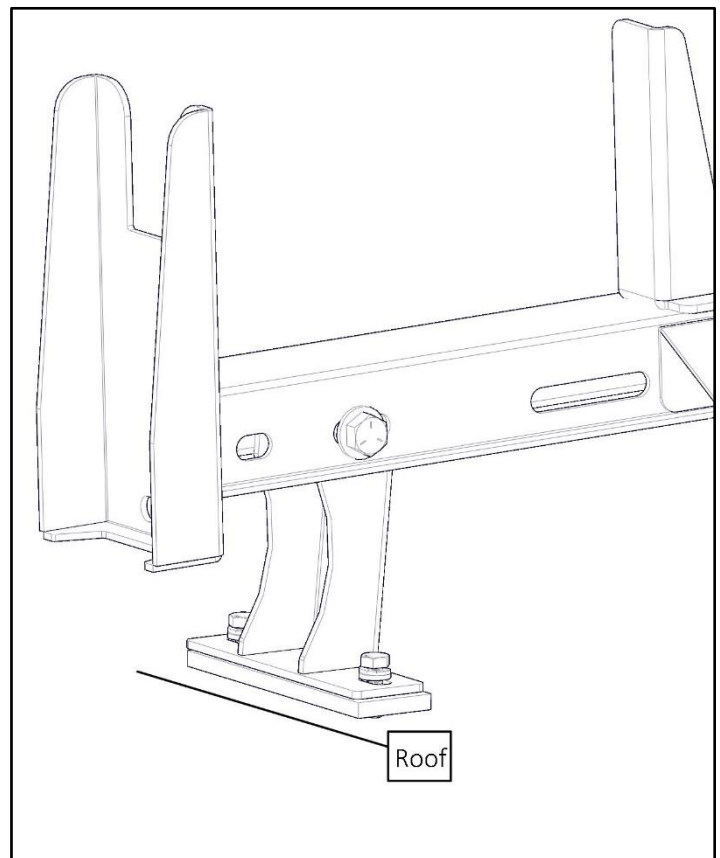
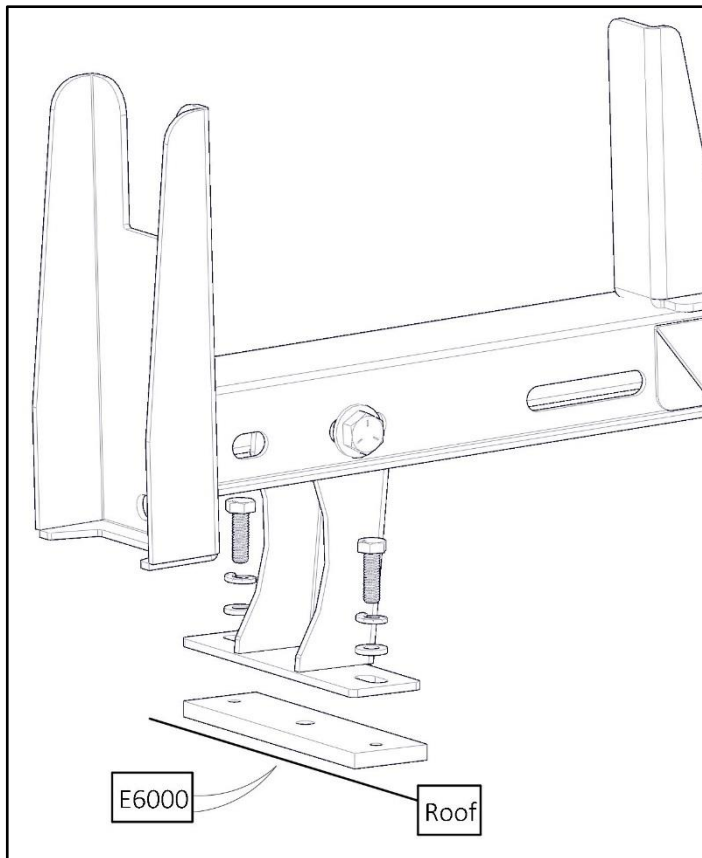

Step 3

- Go back and tighten all bolts including nuts and bolts on the rack itself.

NV

Step 1

- Locate desired mounting location in the roof of van.

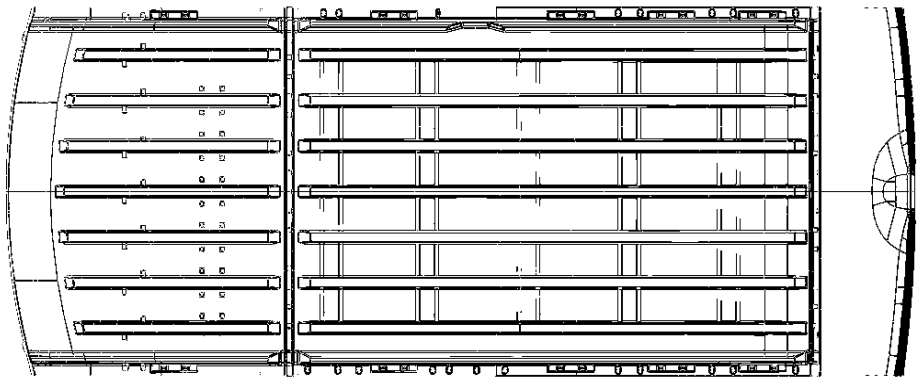

Step 2

- Install M8 U-Nuts (13) as shown.

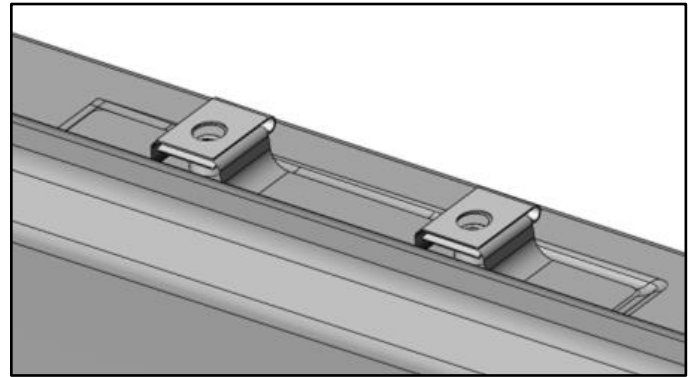
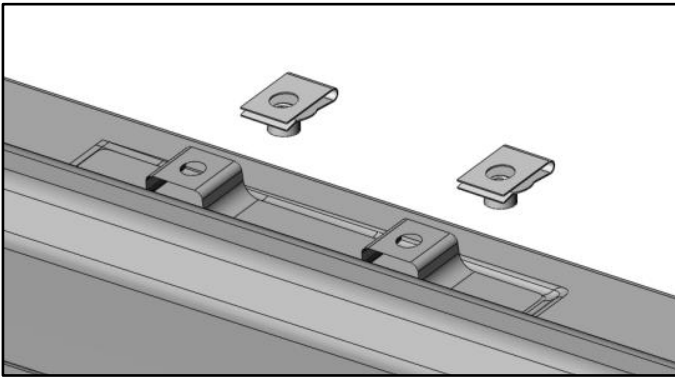

Step 3

- Bolt through the mount foot (B) into the previously installed M8 U-nuts using M8 x 20mm hex head (9), M8 lock washer (11) and M8 flat washer (12).

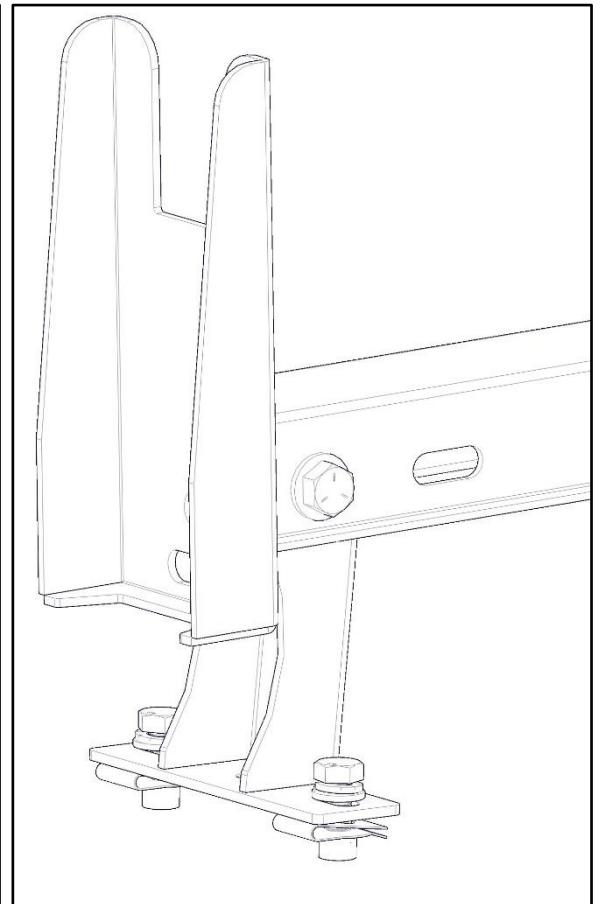
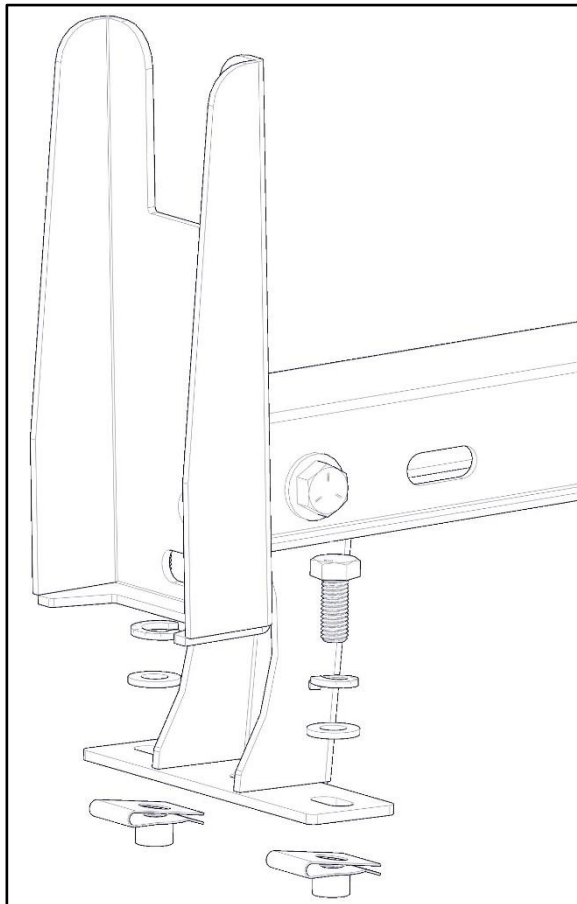

Step 4

- Go back and tighten all bolts including nuts and bolts on the rack itself.