

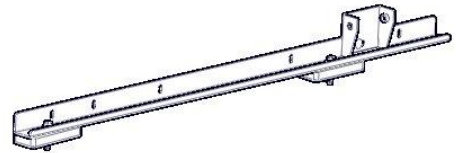

WE PUT EVERYTHING WITHIN REACH.

Installation Guide

408TC

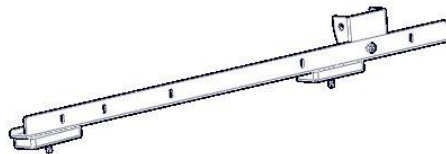

***PLEASE READ ALL INSTRUCTIONS AND WARNINGS PRIOR TO ASSEMBLING,
INSTALLING, AND USING THIS PRODUCT***

Warning



Always check for wires, fuel tanks and lines, brake lines and other important vehicle functionality items prior to drilling and installing all products.

Tools Needed

13mm Wrench and Socket	1/2" Wrench and Socket
5mm Allen Hex	9/16" Wrench and Socket

Before You Begin

- Read ALL instructions prior to installation.
- Feet mount locations will vary based on size of van and rack type.

***When installing on Ford Transit, be sure to put sealant around exposed threads in roof.**





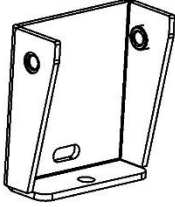
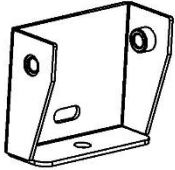
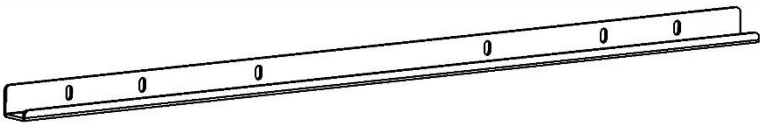
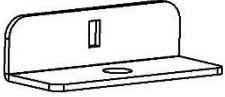
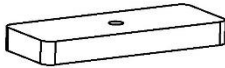

Seal between the roof and the rubber pad.

Put some on the threads of the bolt going into roof*

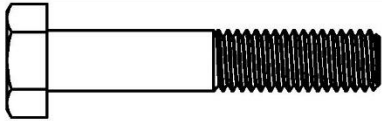
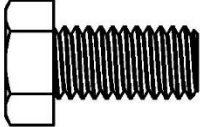
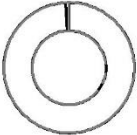
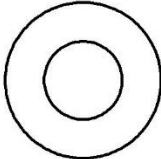
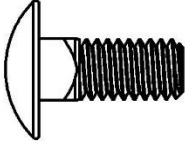
Parts

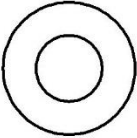
ITEM NO.		PART NUMBER	DESCRIPTION	QTY.
A		40800-17	Tall Foot (Rear Foot)	2
B		408TC-00-001	Short Foot (Front Foot)	2
C		4A901-10-001	Front Rail	2
D		4A9ST-00-001	RR BRK	2
E		T249-01	Thick Plate	4
		18-408TC	Hardware	1

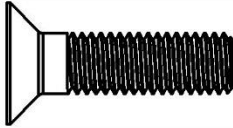
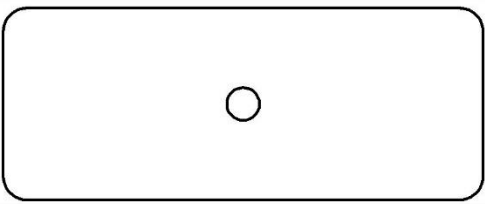
Hardware

ITEM NO.	TO SCALE	PART NUMBER	DESCRIPTION	QTY.
1		95327A569	M8 x 45mm Hex Head	4
2		92865A622	3/8" x 3/4" Hex Head	8
3		91102A760	3/8" Split Lock Washer	8
4		90126A031	3/8" Flat Washer	8
5		90185A581	5/16"-18 x 3/4" Carriage Bolt	4
6		95615A160	5/16" Nyloc	4
7		90850A150	5/16" Flat Washer	8
8		91104A030	5/16" Split Lock Washer	4
9		91263A845	M8 x 30mm Flat Head	2
10		T249-02	EPDM Rubber 3MM Scale 1:2	6
11		BH-821	SEALANT	1

Ford Transit (EXCLUDING High Roof EXT)

Step 1 - Rear Foot Mounting

- Locate threaded emboss at rear of van. Plugs will need to be removed.

130" Wheel Base

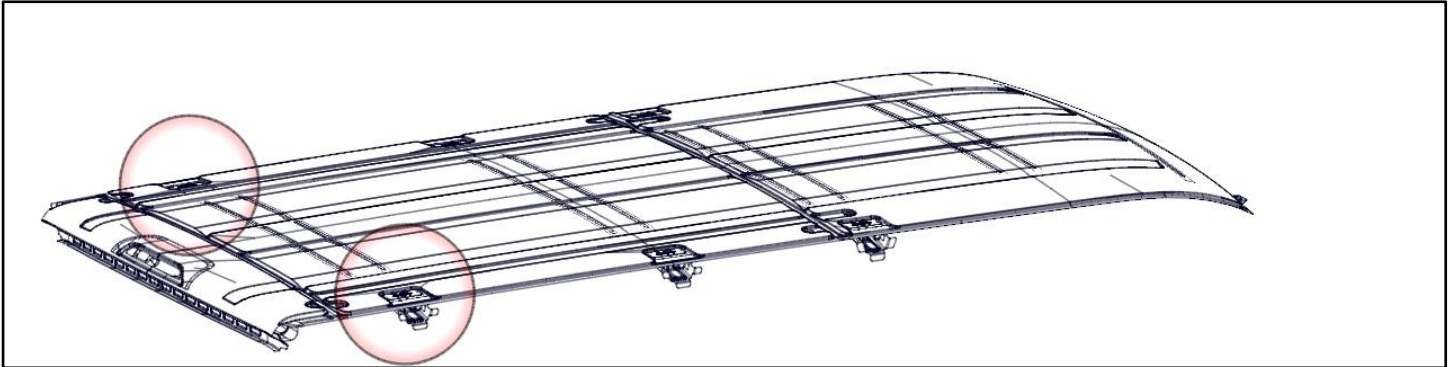

148" Wheel Base

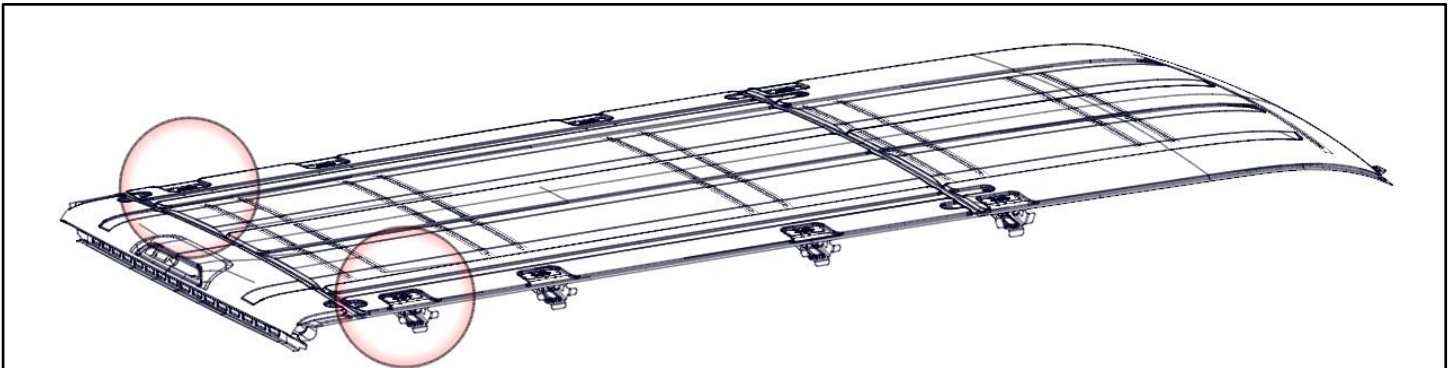

- Mount the rear mount bracket with M8 x 30mm Flat Head bolts. Place rubber pad between the bracket and the roof of the van. Place the bracket parallel with the length of the van.
- Have the flange on the bracket towards the outside of the van as shown.
- Passenger side shown, repeat on driver side.
- **Be sure to place sealant around the threads and under the rubber pad to ensure no water can leak into the cabin of the van.**
- Tighten.

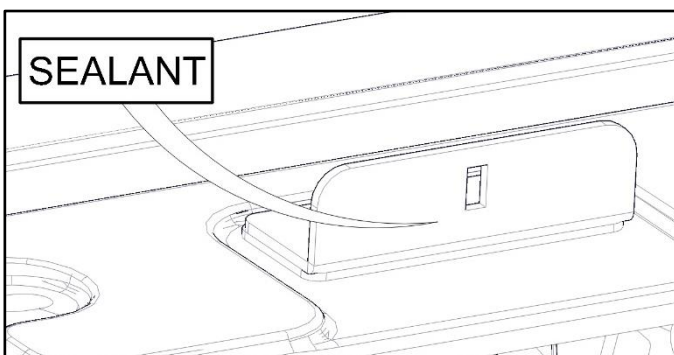
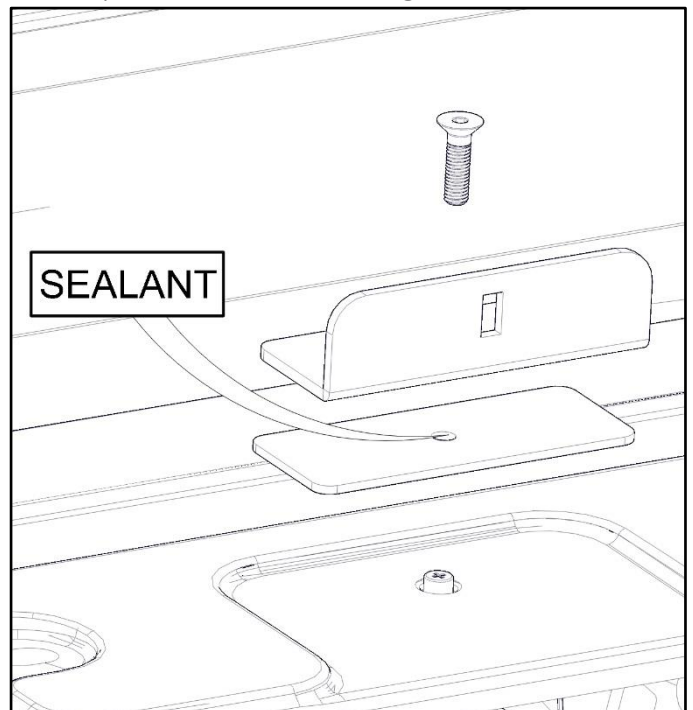

Step 2A – Front Mount on 130” WB (Low/Mid Roof)

- Locate the other threaded emboss at the front of van. Plugs will need to be removed.

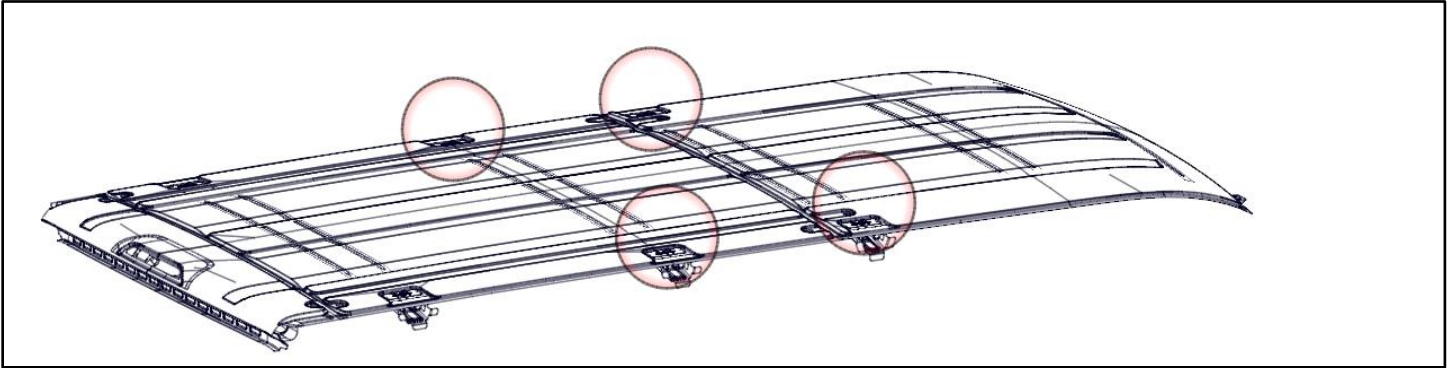

- Place the long mount rail with the tall flange to the center of the van.
- Bolt through the farthest rear slot and the corresponding front slot in the rail using M8 x 45mm bolts with lock washers and flat washers.
- The rail should be offset to the front of the van.
- The picture shown here is the rear most mount on the rail.
- **Be sure to place sealant around the threads and under the rubber pad to ensure no water can leak into the cabin of the van.**

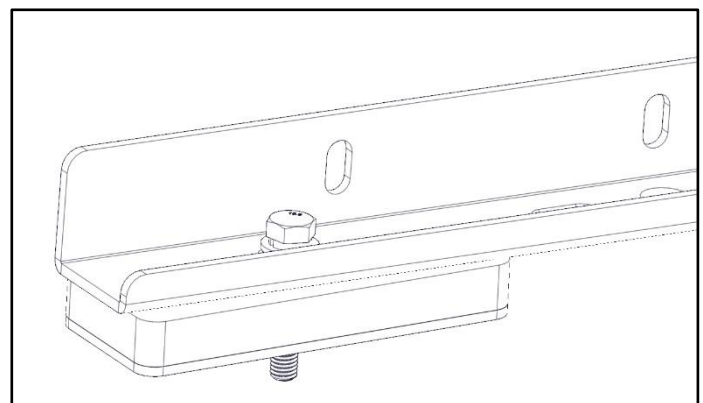
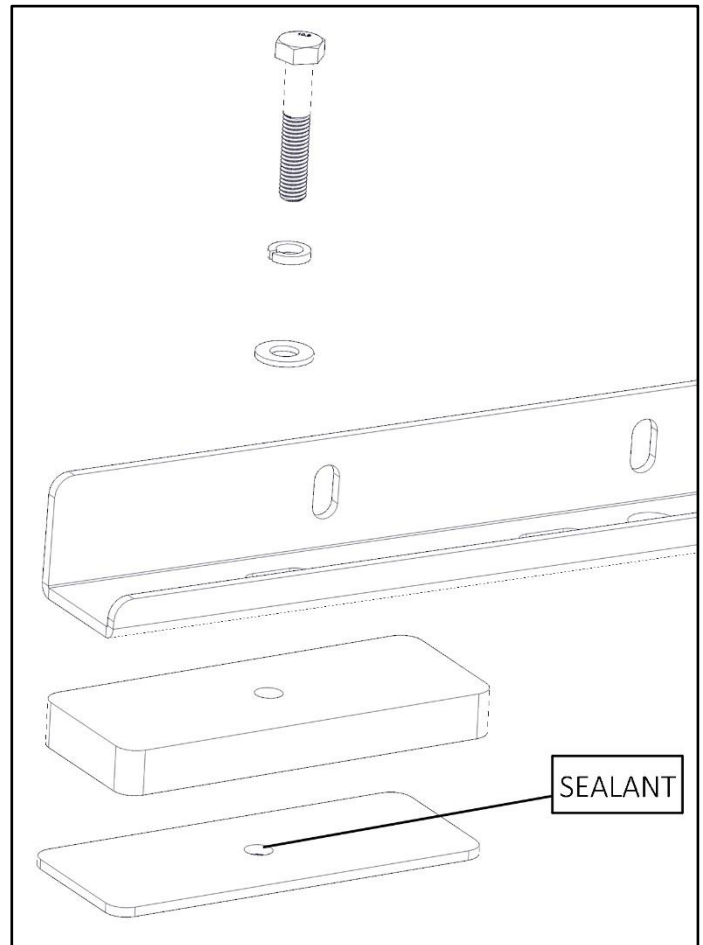

- Passenger side shown, repeat on driver side.
- Snug Tighten

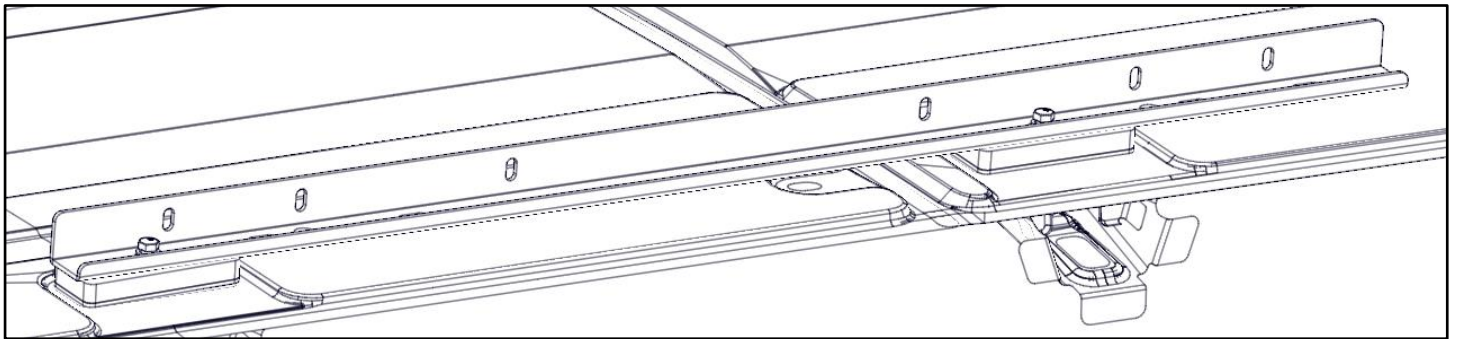
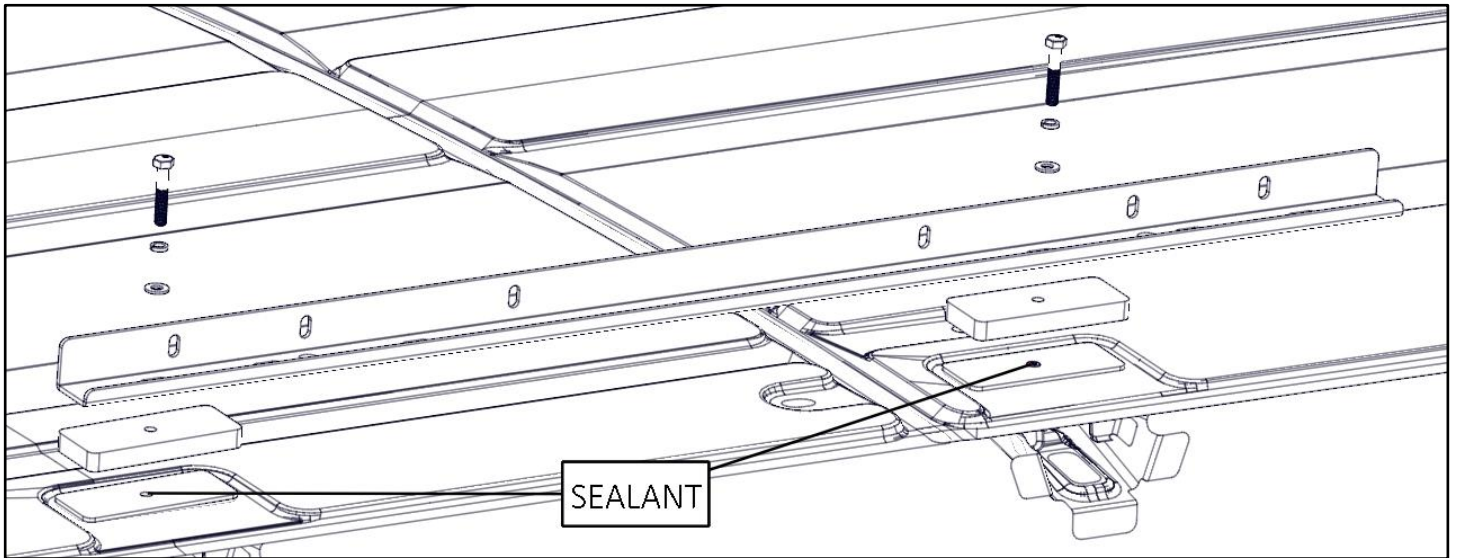

Step 2B – Front Mount on 148” WB (Low/Mid/High Roof exclude EXT)

- Locate the other threaded emboss at front of van. Plugs will need to be removed

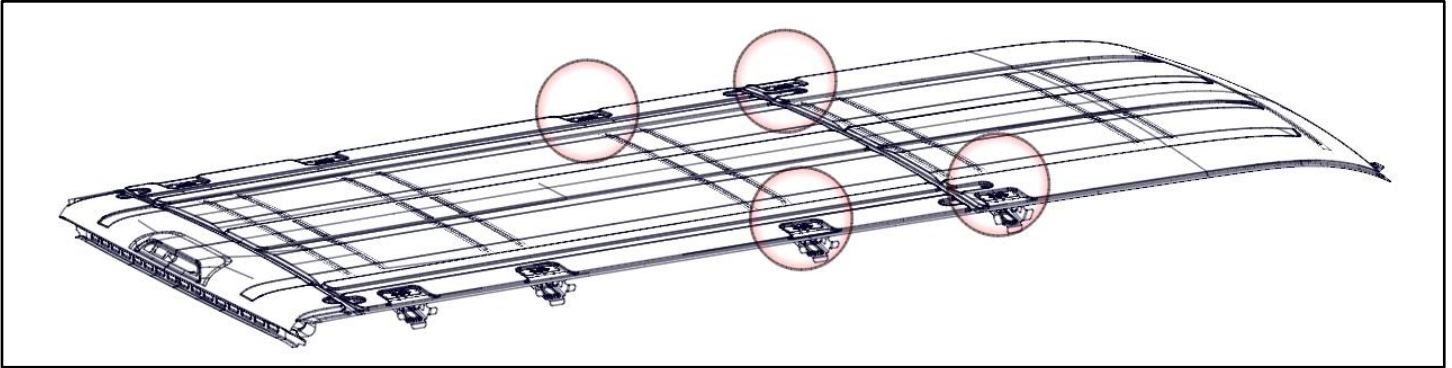

- Place the long mount rail with the tall flange to the center of the van.
- Bolt through the farthest rear slot and the corresponding front slot in the rail using M8 x 45mm bolts with lock washers and flat washers.
- The rail should be offset to the front of the van.
- The picture shown here is the rear most mount on the rail.
- **Be sure to place sealant around the threads and under the rubber pad to ensure no water can leak into the cabin of the van.**

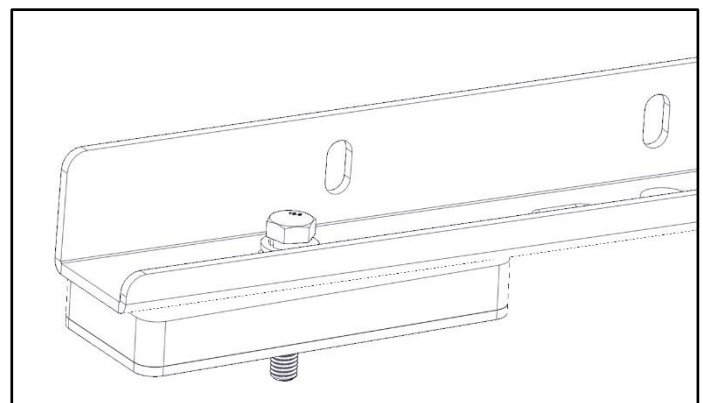
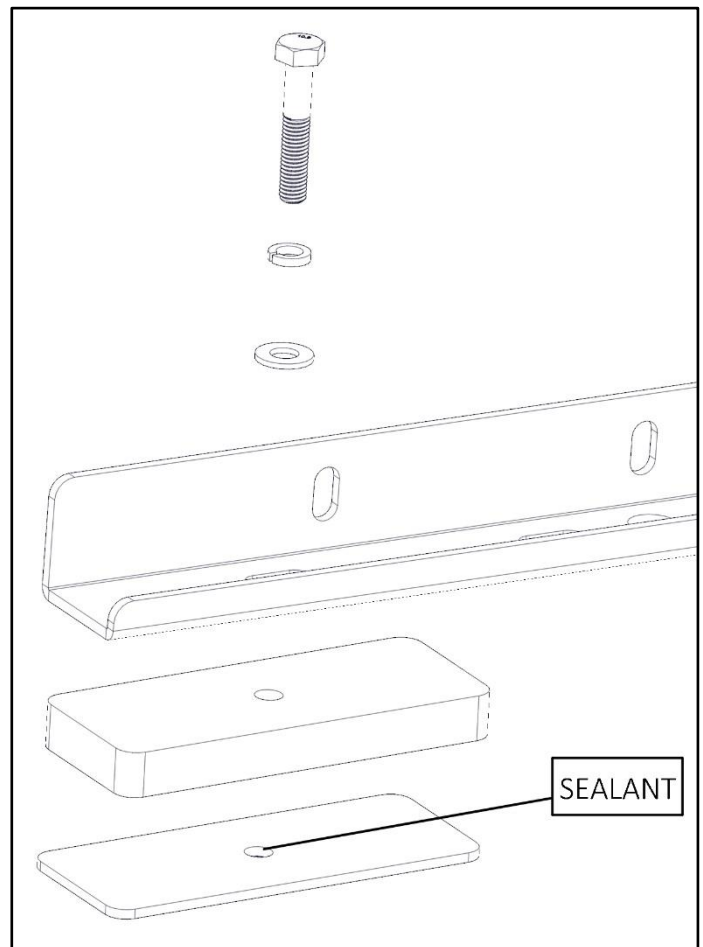

- Passenger side shown, repeat on driver side.
- Snug Tighten

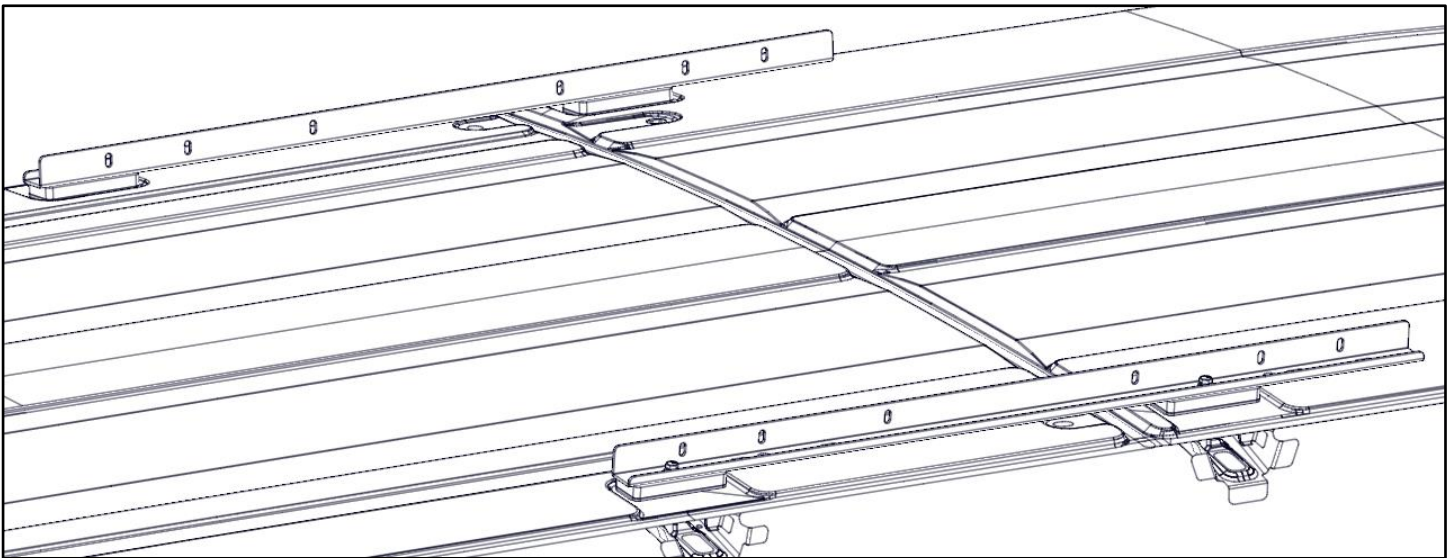
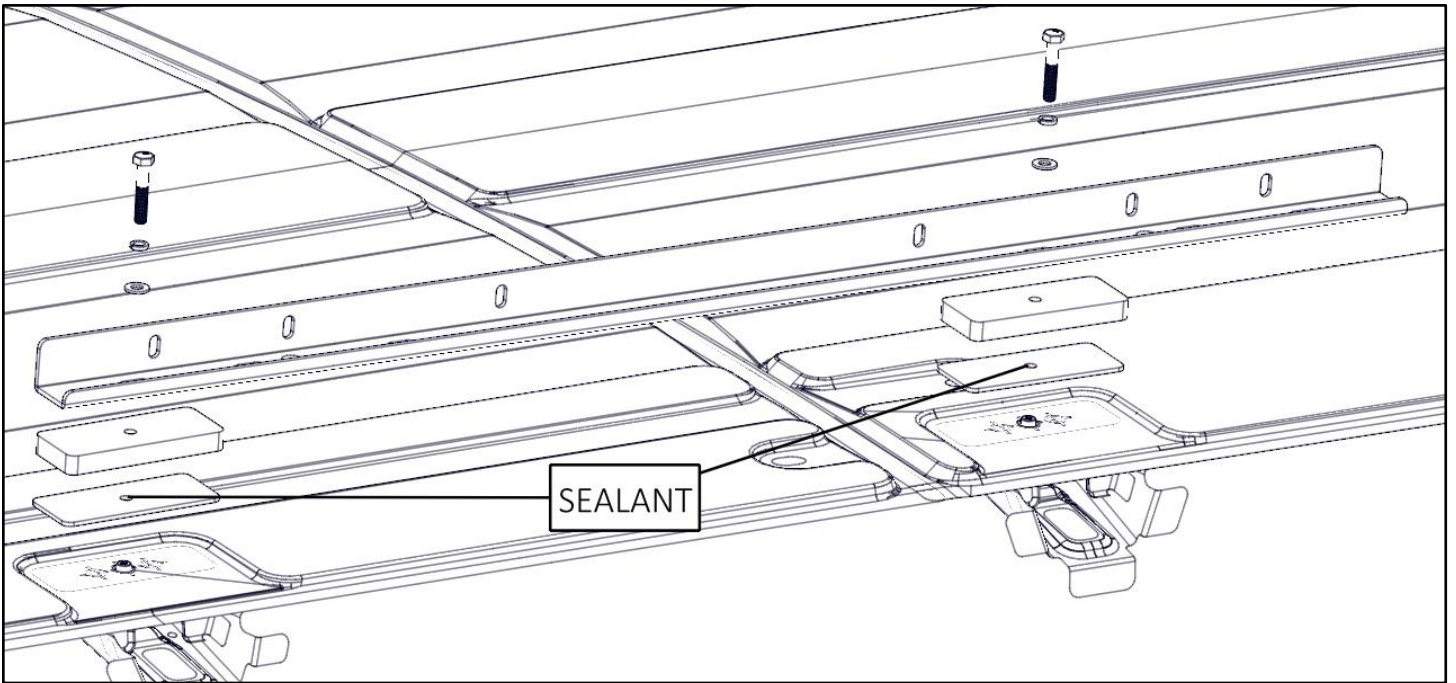

Transit 148" Wheelbase, High Roof, EXT

Step 3A- EXT Rear Foot Mounting

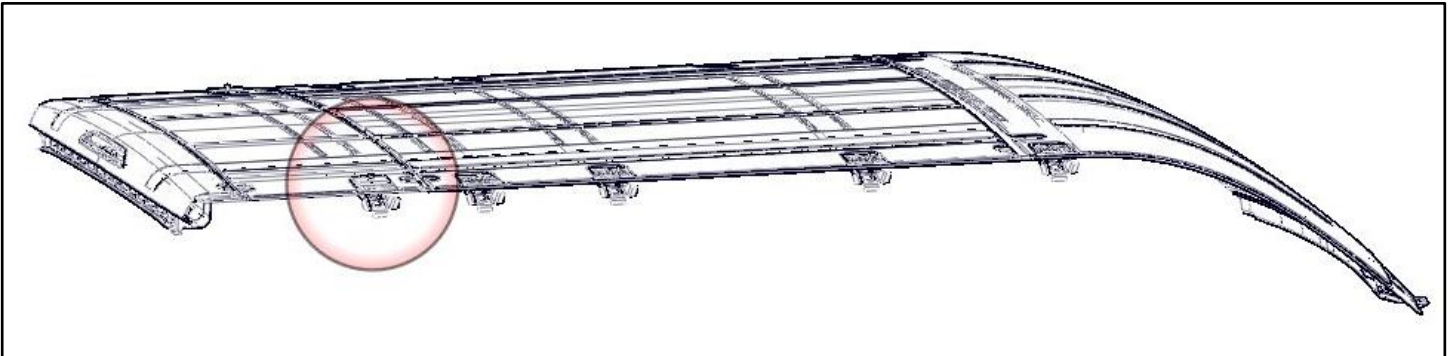

- Mount the rear mount bracket with M8 x 30mm Flat Head bolts. Place rubber pad between the bracket and the roof of the van. Place the bracket parallel with the length of the van.
- Have the flange on the bracket towards the outside of the van as shown.
- Passenger side shown, repeat on driver side.
- **Be sure to place sealant around the threads and under the rubber pad to ensure no water can leak into the cabin of the van.**
- Tighten.

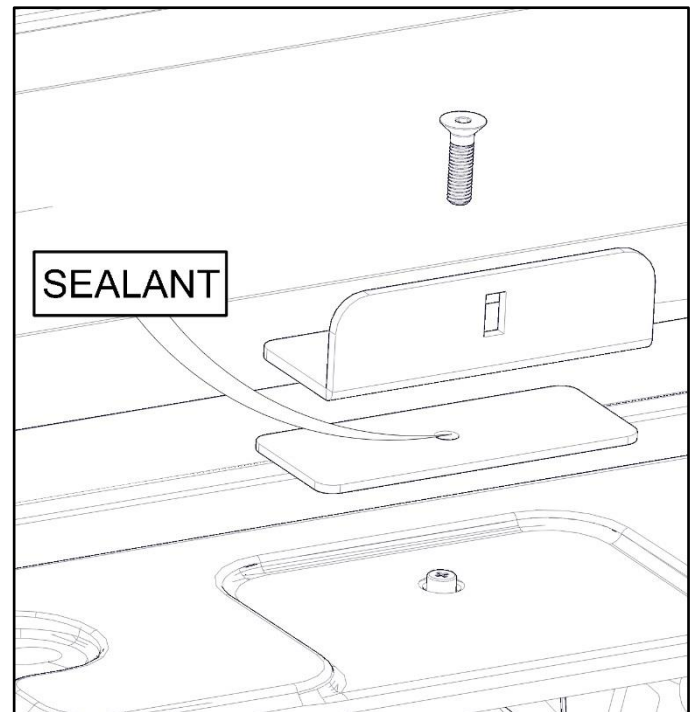
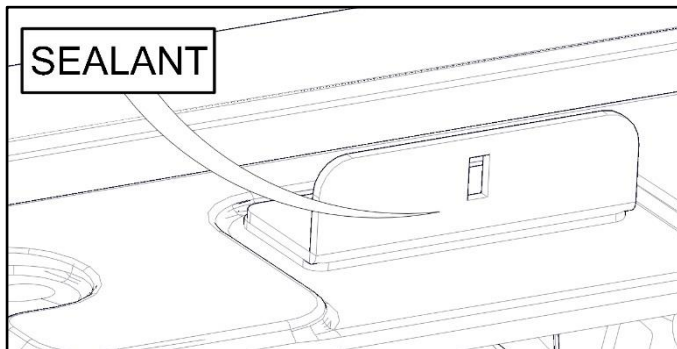

Step 3B- EXT Front Mount

- Locate other two threaded emboss at front of van. A plug will need to be removed.

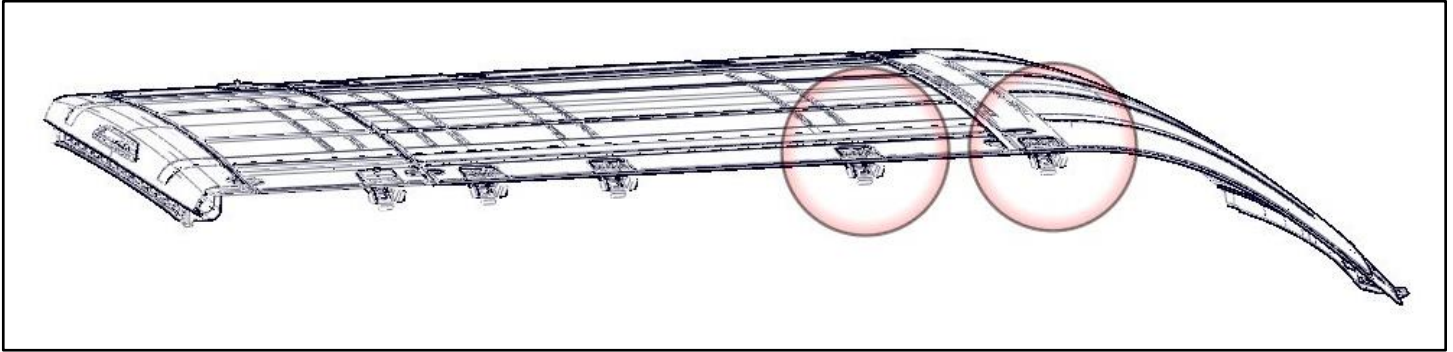

- Place the long mount rail with the tall flange to the center of the van.
- Bolt through the farthest rear countersunk hole and the 2nd slot from the front using M8 x 45mm bolts with lock washers and flat washers.

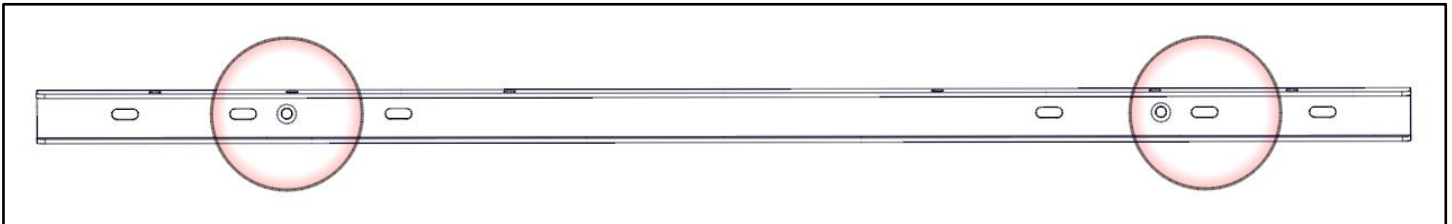

- The picture shown here is the rear most mount on the rail. (through the countersunk hole)
- Passenger side shown, repeat on driver side.
- **Be sure to place sealant around the threads and under the rubber pad to ensure no water can leak into the cabin of the van.**
- Snug Tighten.

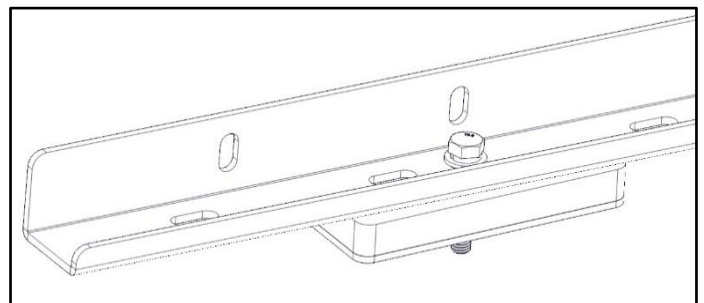
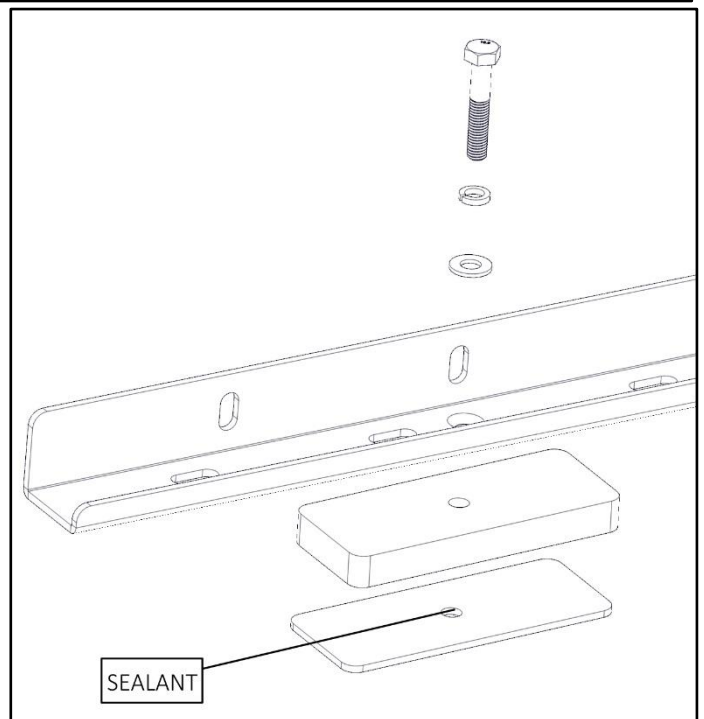

Installing Feet

- Have rack assembled.
- Measure width between the mounts on the van.
- On the cross bows, use the slots that correspond to the measured distance between rails.
- Bolt feet to bows as shown, DO NOT TIGHTEN at this point.
- Feet can be installed as shown or reverse depending on how you mounted the rail.
- Use a 3/8" x 3/4" hex head bolt, 3/8" lock washers and a 3/8" flat washer to bolt feet to crossmembers. Snug Tighten, but allow movement.
- Design of feet may vary, but all mounting is the same.

The tall feet will be installed on the rear bow

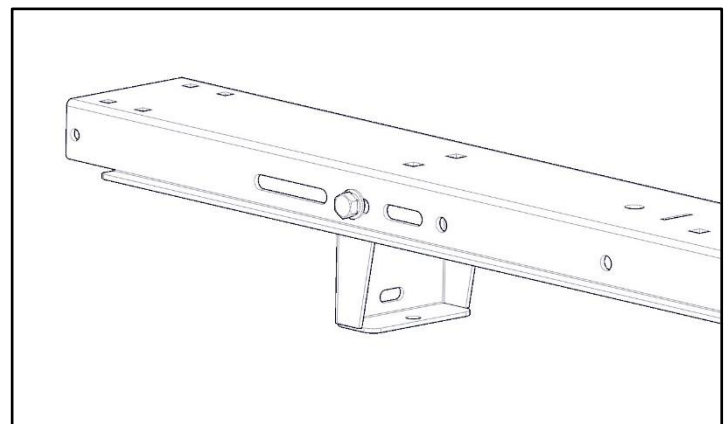
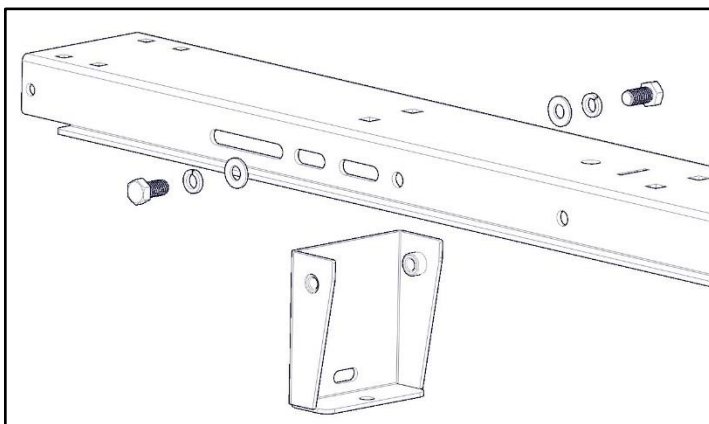
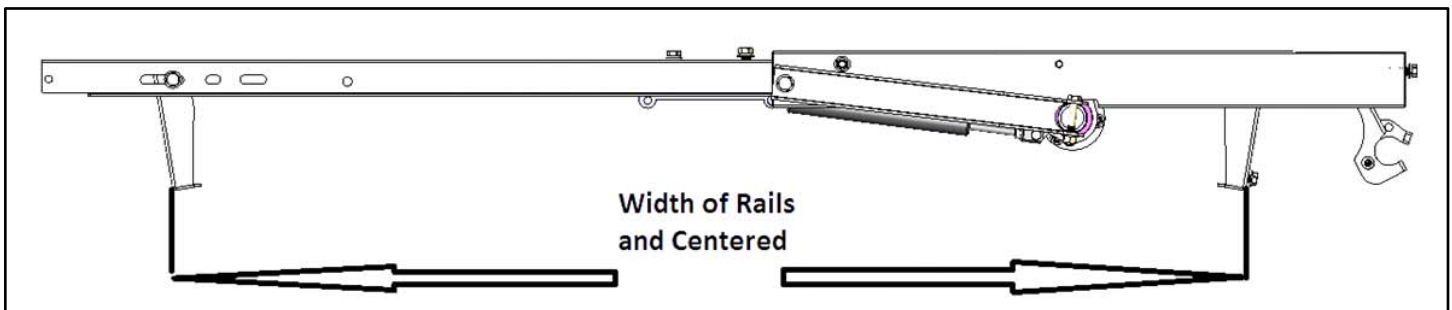

Installing Rack on Van

- First, line the rear foot up with the rear mount of van.
- Bolt rear foot to rear mount using 5/16" x 3/4" carriage bolts, 5/16" flat washers and a 5/16" nyloc nuts. (Driver Side Shown without roof and rack for clarity)
- In the front of the van, mount foot to previously installed rail using a 5/16" 3/4" carriage bolts, 5/16" flat washers and a 5/16" nyloc nuts
- Adjust as necessary.
- Notice, the tall feet are installed at the rear.

Shown without rack and roof for clarity

REAR

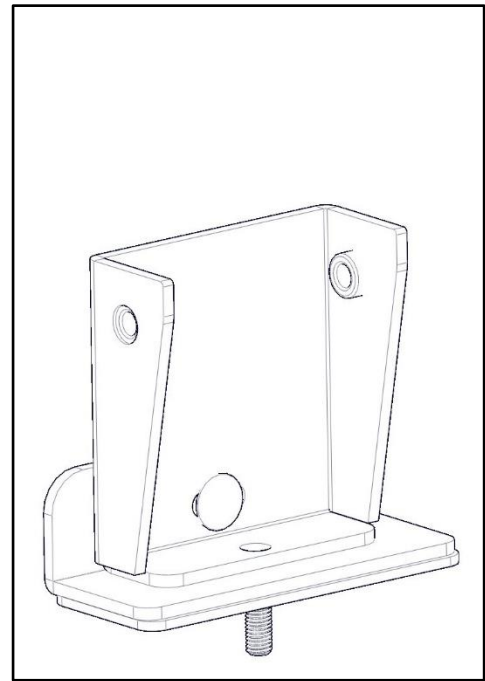
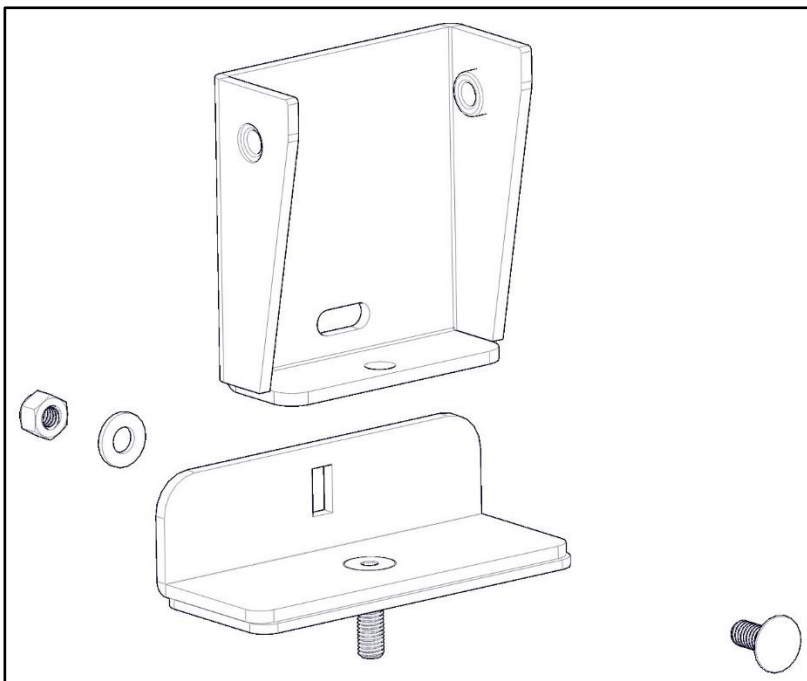

FRONT

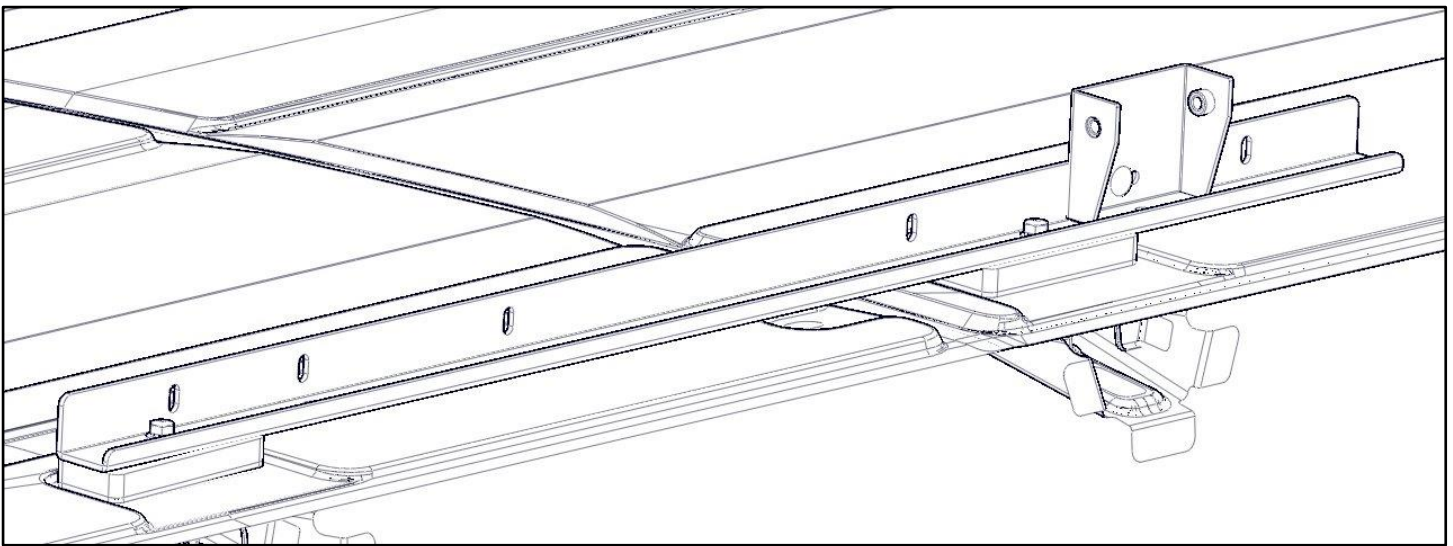
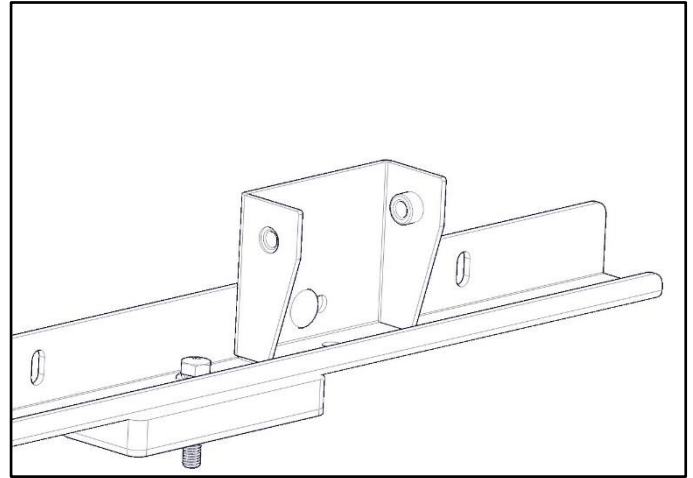
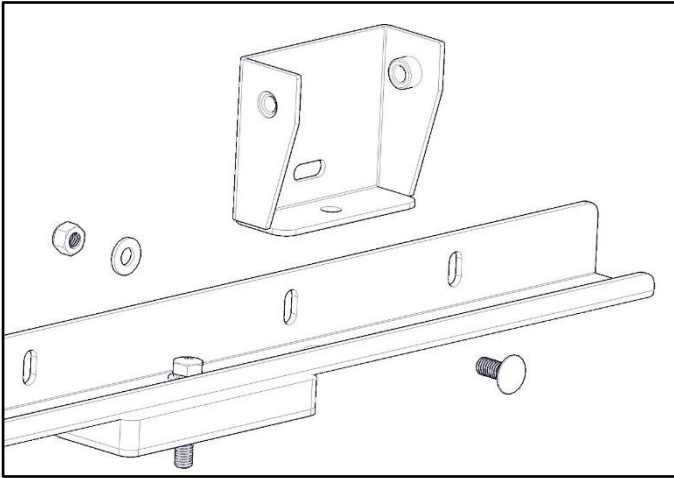

Notice the short feet are installed at the front.

Go back and ensure all hardware is tight. This includes into the roof, within the rack assembly and the mounting of the rack to roof brackets.

Your installation is complete.

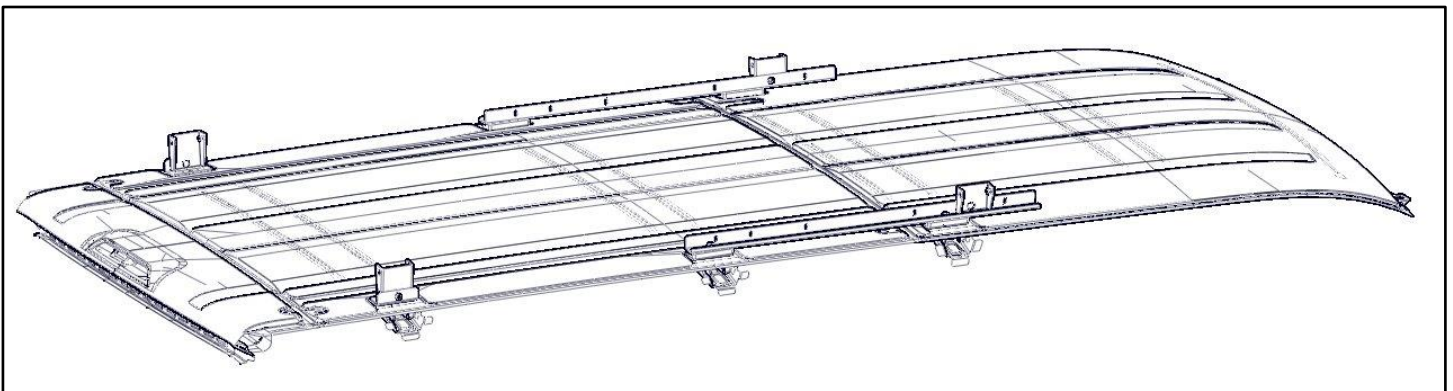

KARGO MASTER®

WE PUT EVERYTHING WITHIN REACH.

Instruction Guide

4082L

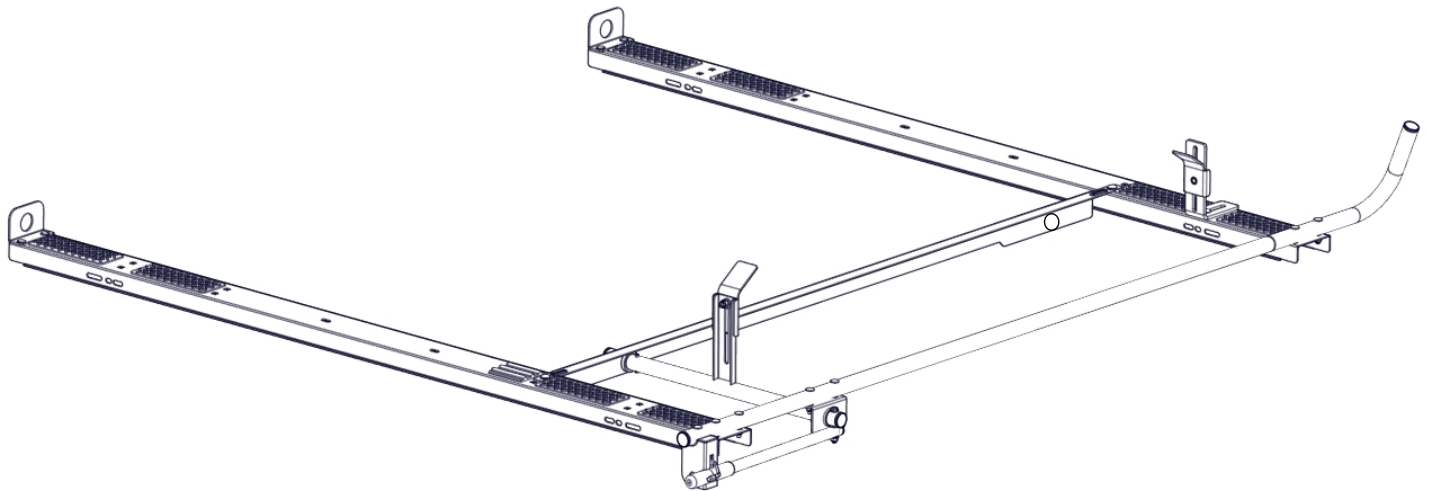

*PLEASE READ ALL INSTRUCTIONS AND WARNINGS PRIOR TO ASSEMBLING,
INSTALLING, AND USING THIS PRODUCT*

Warning



Always check for wires, fuel tanks and lines, brake lines and other important vehicle functionality items prior to drilling and installing all products.



Tools Needed

9/16" Socket and Wrench	1/2" Socket and Wrench
-------------------------	------------------------



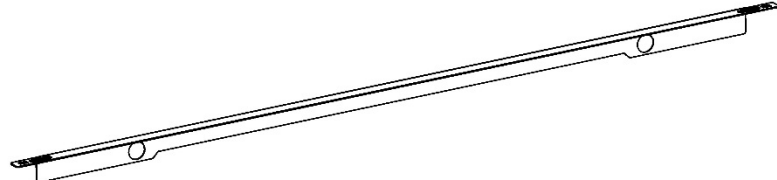
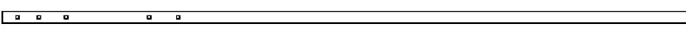

Before You Begin

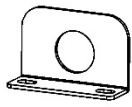
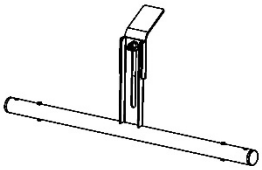
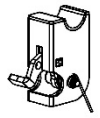
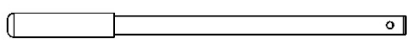
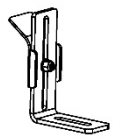
- Read all instructions. Find your vehicle roof rail mounting prior to rack assembly.
 - Most times it is easier to install on top of roof, after the mount kit has been installed.
 - Be sure to put E6000 sealant around all threads entering cargo area and between the rubber spacer and roof of vehicle to prevent water from leaking into cargo area.
 - **DO NOT EXCEED MANUFACTURERS WEIGHT CAPACITY FOR ROOF**
-

Parts

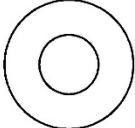
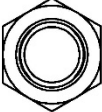
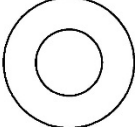
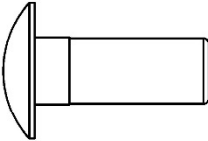
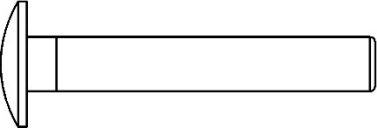
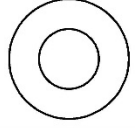
ITEM NO.		PART NUMBER	DESCRIPTION	QTY.
A		4090L-10-001	BOW W/ PADS	2
B		11-03005-R2	LONG ANGLE BRK	1
C		40800-50-001	PS TUBE	1
D		40800-50-002-R1-R	PS BEND TUBE	1
E		11-03027	ANGLE BRK	3
F		13-03007-R1	PIVOT LADDER CLAMP ASM	1
G		40813-44	HANDLE CLAMP ASM	1
H		13-03008-R2	HANDLE ASM	1
J		13-03009	LADDER CLAMP ASM	1
		18-4820L	MOUNT HARDWARE	1

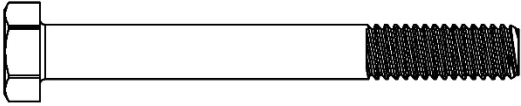
Hardware (18-40800)

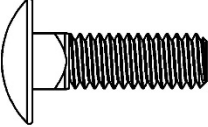
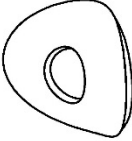
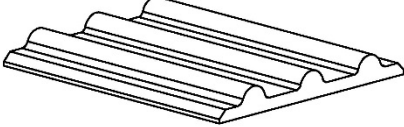
ITEM NO.	TO SCALE	PART NUMBER	DESCRIPTION	QTY.
1		90295A160	.06x.34x.75 Nylon Washer	2
2		.375-16 NYLOC	3/8-16 Nyloc Nut	3
3		.375 FLAT WASHER	3/8 Flat Washer	3
4		.375-16 x 1 Carriage	3/8-16x1 Carriage Bolt	3
5		.312-18x2.0 CARRIAGE BOLT	5/16-18x2.0 Carriage Bolt	7
6		96659A107	5/16 FLAT WASHER	12
7		91831A030	5/16 NYLOC	12
8		.312-18 X 2.75 HEX BOLT	5/16-18x2 3/4 Hex Bolt	1
9		40800-10-007	PLASTIC BUSHING 1:2 SCALE	2
10		90185A583	5/16 x 1 CARRIAGE	4
11		91844A230	5/16 CONTOUR WASHER	1
12		Extra Rubber Pad	1:2 SCALE	1

Step 1 – Ladder Stops

- Bolt ladder hooks to one end of each bow.
- Use a 5/16" carriage bolt, 5/16" washers and a 5/16" nylock.
- TIGHTEN. Skip if adding 4081L.

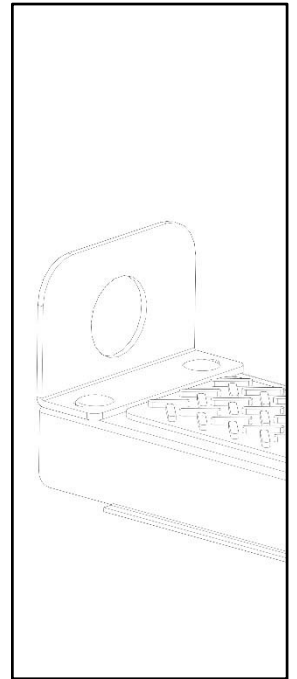
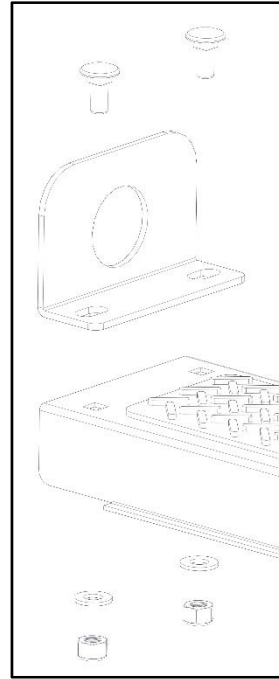
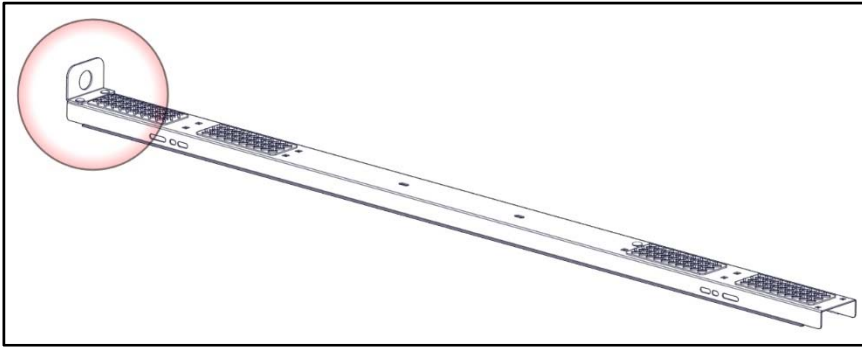

Step 2 – Bows to Feet

- Place both bows on top of installed rails. Bolt feet to rails. Use hardware from mount kits.
- Put the ladder hooks on the driver side of vehicle.
- Snug Tighten, but allow movement.

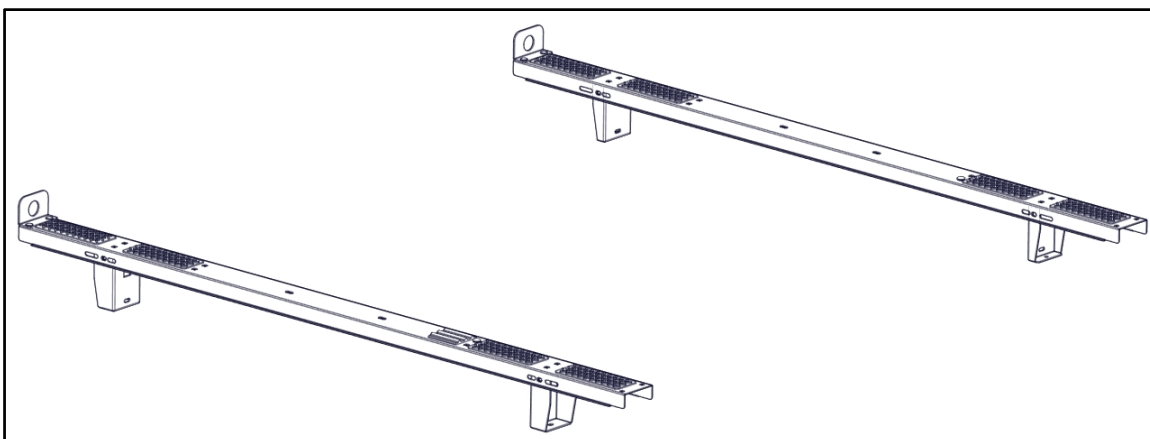
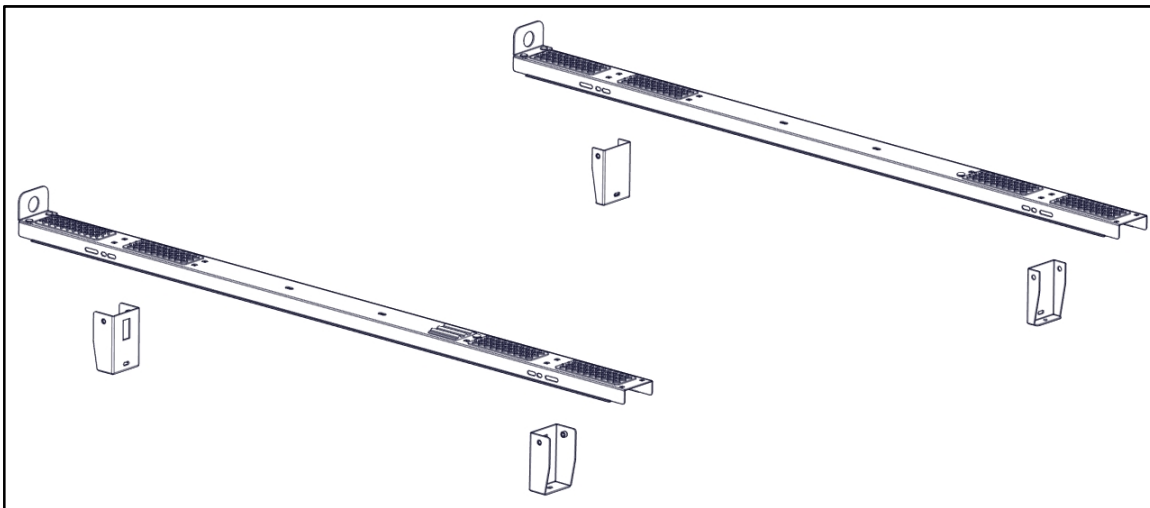

Step 3 – Mount Side Tube

- Place side tube on top of installed bows.
- Have the bend towards the front and to the outside of the vehicle as shown.
- Mount rotation bar plate to the rear of the tube as shown.
- Leave one square slot open at the rear of the side tube.
- Bolt together using 5/16" x 1-3/4" carriage bolt, a 5/16" flat washer and a 5/16" nyloc.
- Snug Tighten, but allow movement.

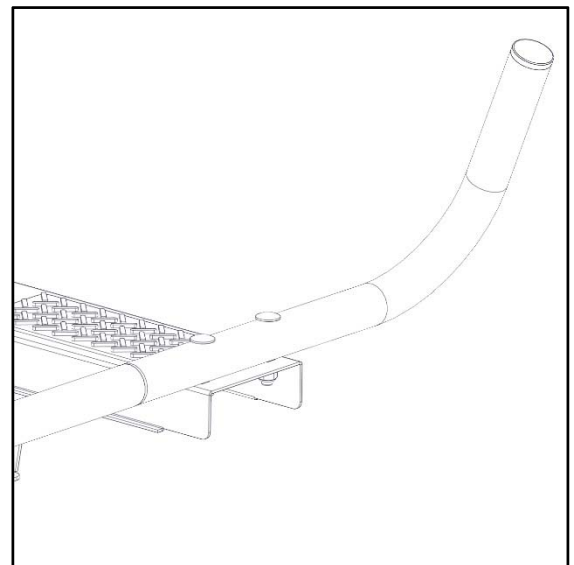
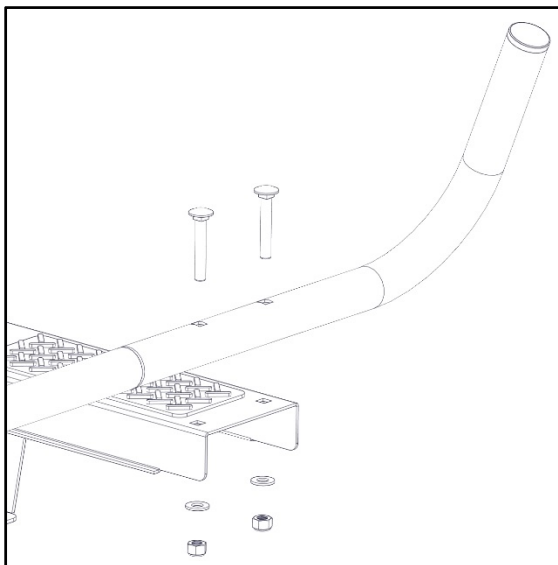
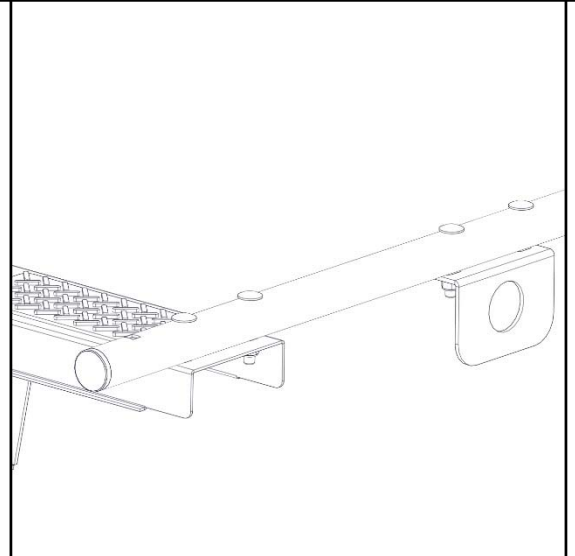
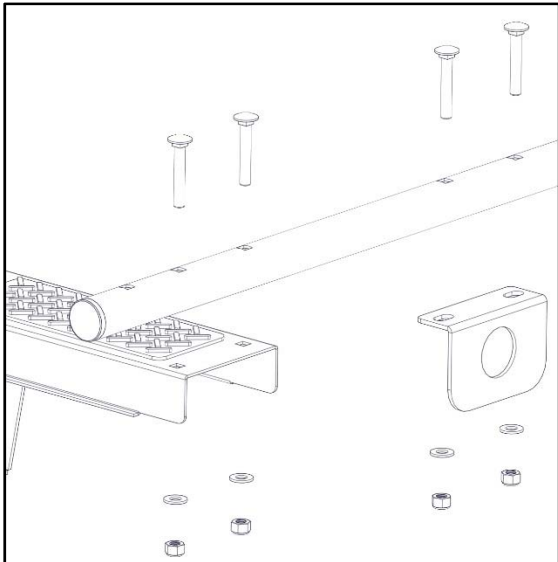
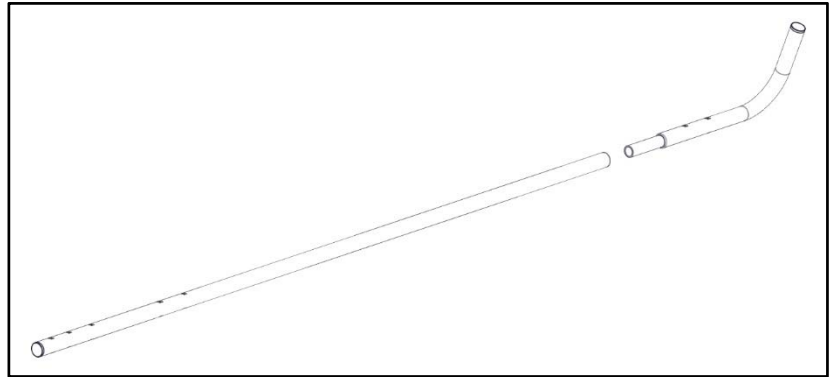
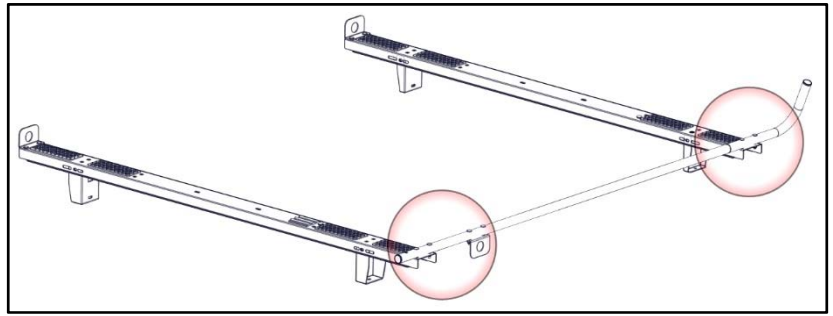

Step 4 – Mount Clamp Tube

- Place clamp and lock L bracket on top of installed bows.
- Insert plastic bushings into the clamp and lock L bracket and the rotation bar plate installed in Step 3, with flange towards each other and to the inside as shown.

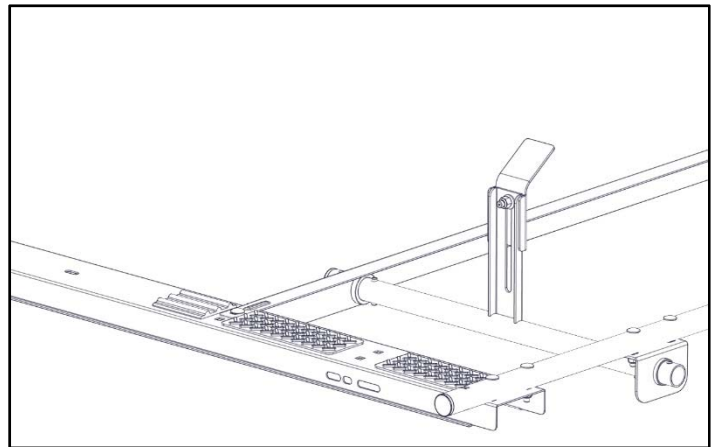
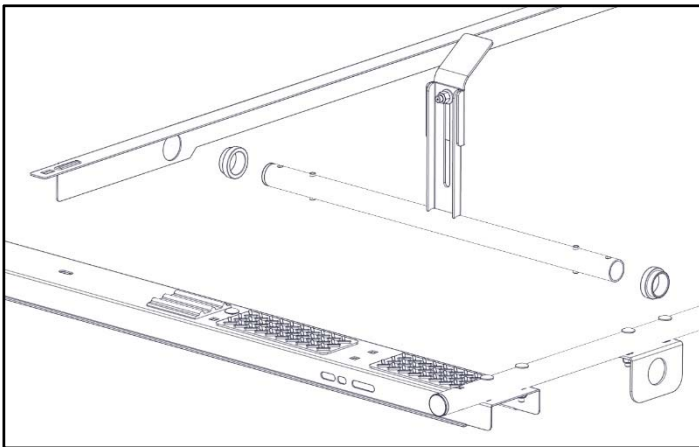
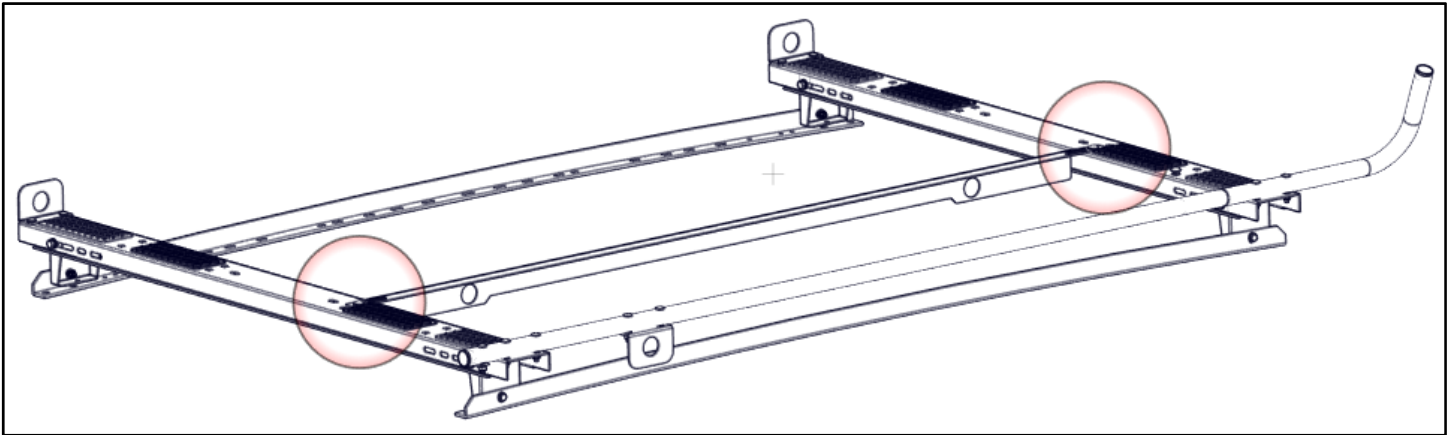

- Insert clamp tube into both plastic bushings.
- Adjust clamp on clamp tube to fit firmly against your ladder.

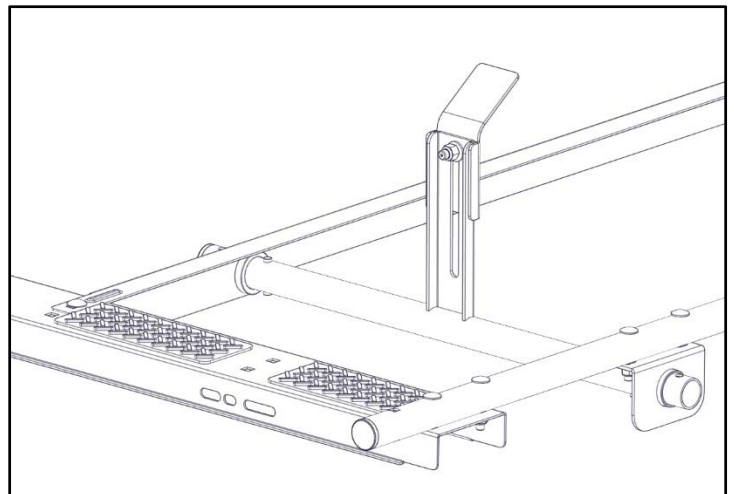
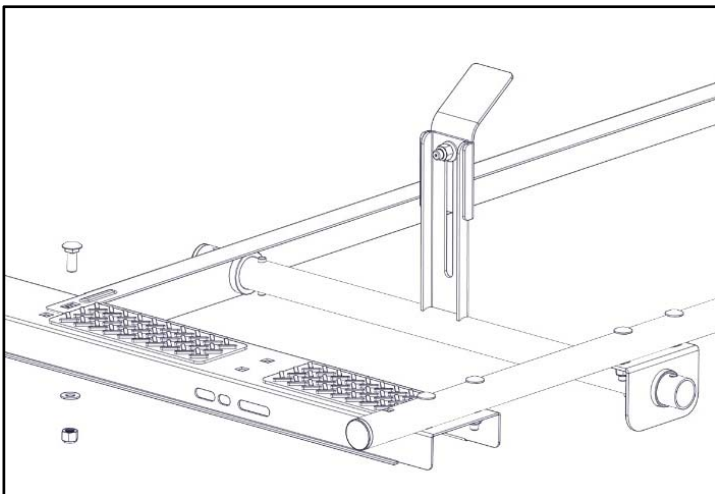

- Bolt clamp and lock L bracket to bows using 3/8" x 1" carriage bolt, 3/8" flat washer and a 3/8" nyloc as shown. (This view shown without clamp tube)
- TIGHTEN

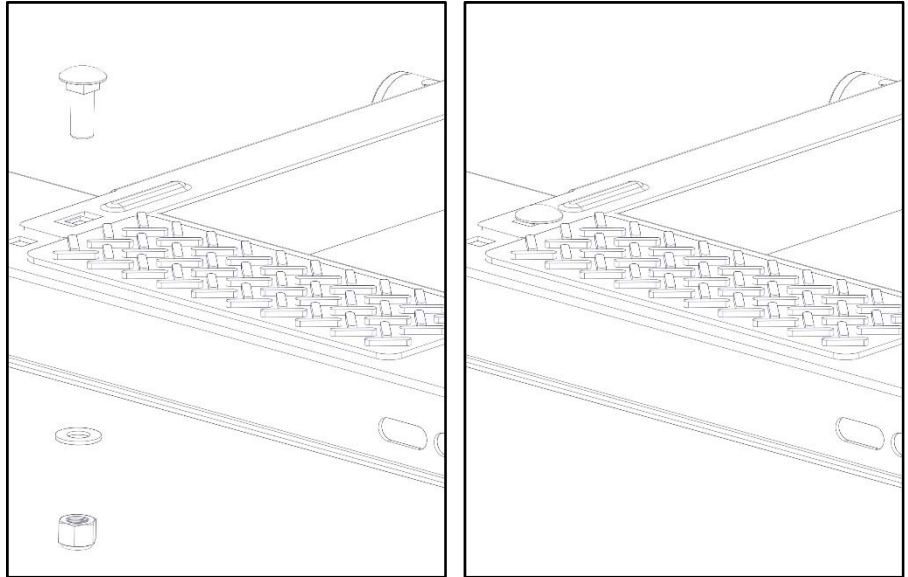

Step 5 – Mount Handle

- Bolt handle to clamp tube using a 5/16" x 2-3/4" hex head, two 5/16" flat washers, 5/16" nylon washer and 5/16" a nyloc. The nylon washer goes in between the clamp tube and handle.
- TIGHTEN

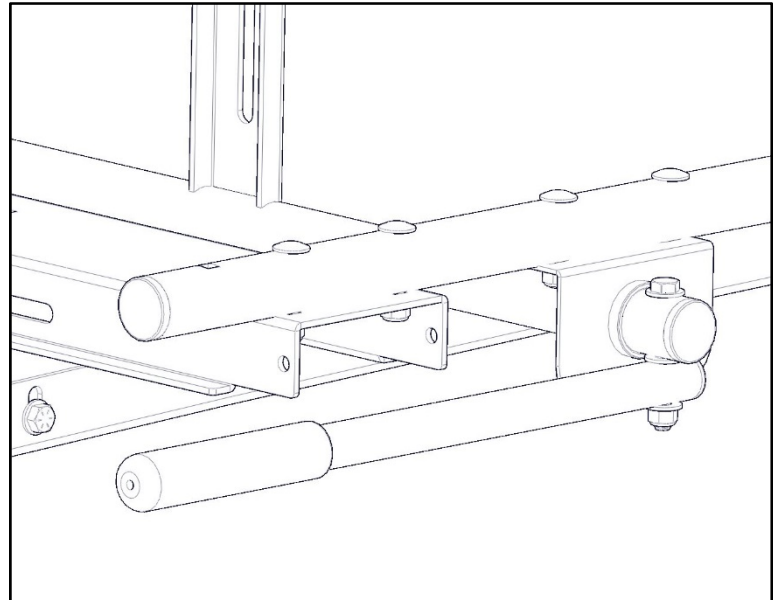
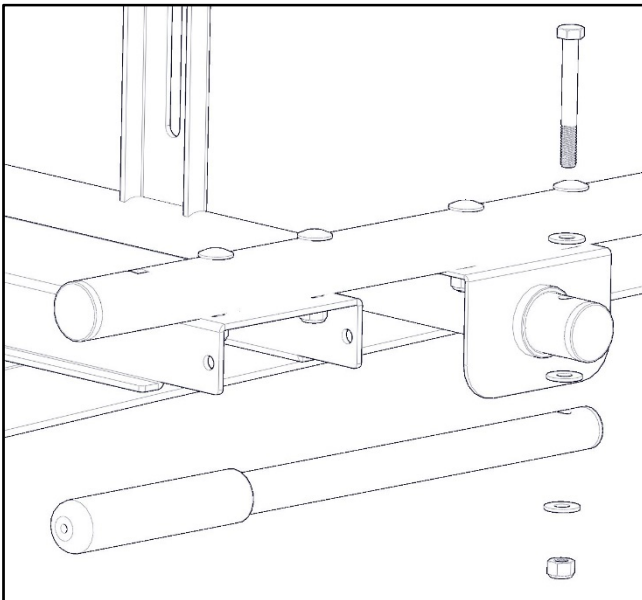

Step 6 – Mount Latch Assembly

- Bolt latch to the rear of the mount tube that was installed in Step 5 using 5/16" x 1-3/4" carriage bolt, 5/16" curved washer and a 5/16" nyloc.
- TIGHTEN

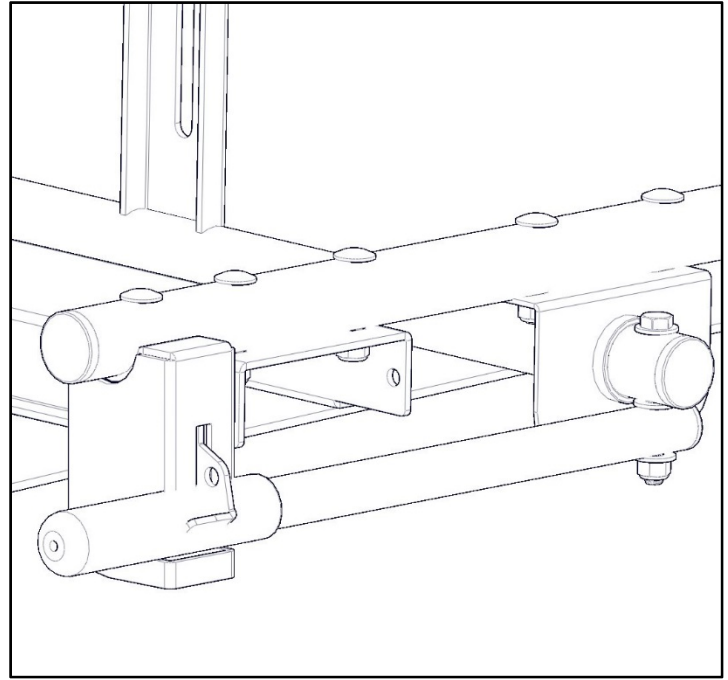
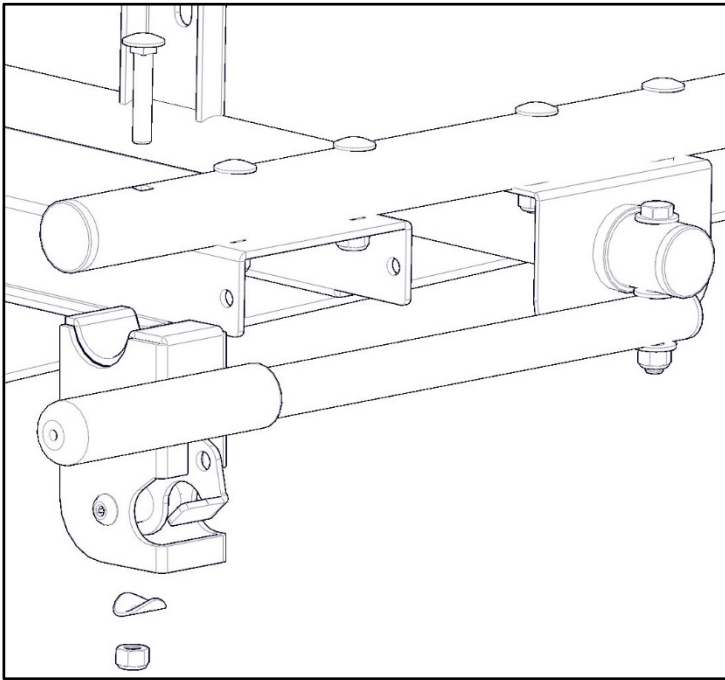

Step 7 – Mount Ladder Hook Bracket to Bow

- Bolt ladder hook bracket to the bow in the orientation shown using a 3/8" x 1" carriage bolt, a 3/8" flat washer and a 3/8" nyloc. Be sure the bracket is square to the bow.
- Adjust clamp on bracket to fit firmly against your ladder.
- TIGHTEN

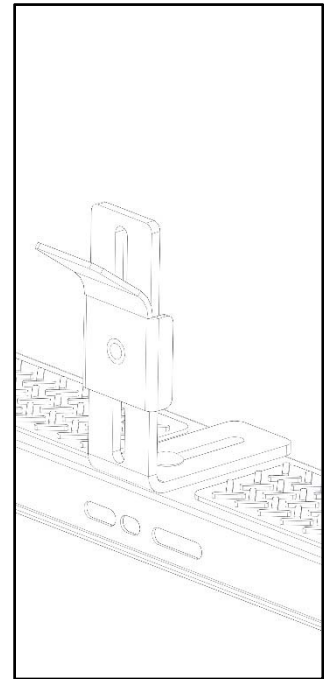
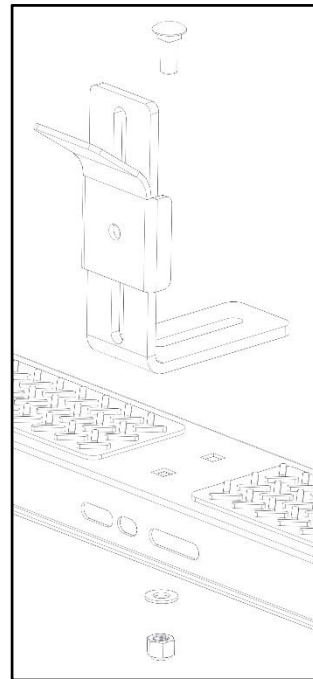

GO BACK AND ENSURE ALL HARDWARE IS TIGHT
Your installation is now complete.