

---

# KARGO MASTER®

**WE PUT EVERYTHING WITHIN REACH.**

---

## Instruction Guide

---

### 409TD

---



---

\*PLEASE READ ALL INSTRUCTIONS AND WARNINGS PRIOR TO ASSEMBLING,  
INSTALLING, AND USING THIS PRODUCT\*

---

## Warning



Always check for wires, fuel tanks and lines, brake lines and other important vehicle functionality items prior to drilling and installing all products.

---

## Tools Needed



13mm Wrench and Socket	1/2" Wrench and Socket
5mm Allen Hex	9/16" Wrench and Socket

---





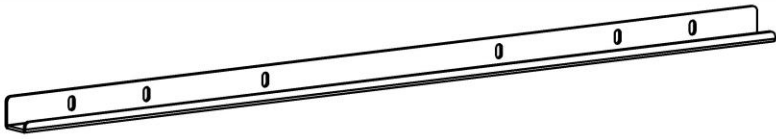
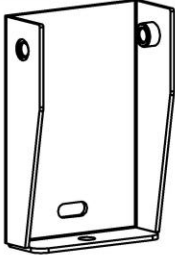
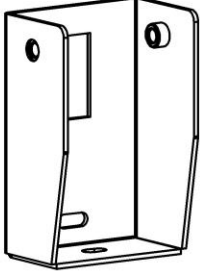

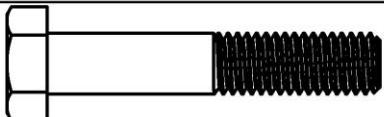
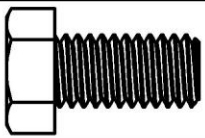

## Before You Begin

- Read ALL instructions prior to installation.
  - Mount locations will vary based on van.
  - Be sure to put sealant around exposed threads in roof. Seal between the roof and the rubber pad. Apply some sealant on the threads of all bolts going into the roof.
-

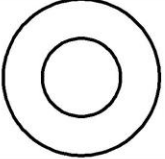
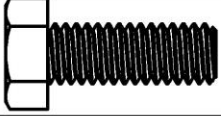
Parts

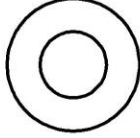
ITEM NO.		PART NUMBER	DESCRIPTION	QTY.
A		4A901-10-001	Front Rail	2
B		13-03105	Tall Foot	2
C		4090T-10-R2	Large Foot	2
D		4A9ST-00-001	Rear Mount Bracket	2
E		T249-01	Black Nylon Block	4
		18-409TD-R2	Hardware	1

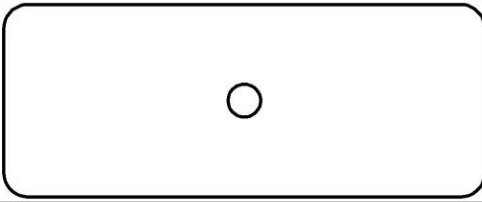
Hardware

ITEM NO.	TO SCALE	PART NUMBER	DESCRIPTION	QTY.
1		95327A569	M8x1.25 x 45mm Hex Head	4
2		92865A622	3/8" x 3/4" Hex Head	8
3		91102A760	3/8" Split Lock Washer	8
4		90126A031	3/8" Flat Washer	8
5		92865A582	5/16" x 7/8" Hex Head	4
6		95615A160	5/16" Nyloc	4
7		90126A030	5/16" Flat Washer	12
8		91102A755	5/16" Split Lock Washer	4
9		91263A845	M8x1.25 x 30mm Flat Head	2
10		T249-02	Rubber Scale 1:2	8
		BH-821	Sealant	1

## Ford Transit (EXCLUDING High Roof Extended)

### Step 1 – Rear Mounting

- Locate the threaded inserts at the rear of the van. Plugs will need to be removed.

#### 130" Wheel Base

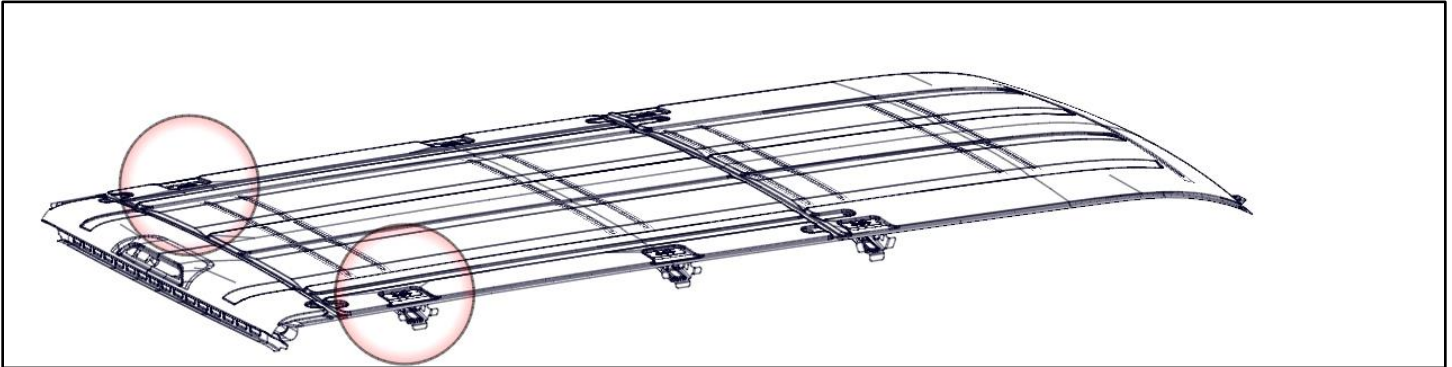

#### 148" Wheel Base

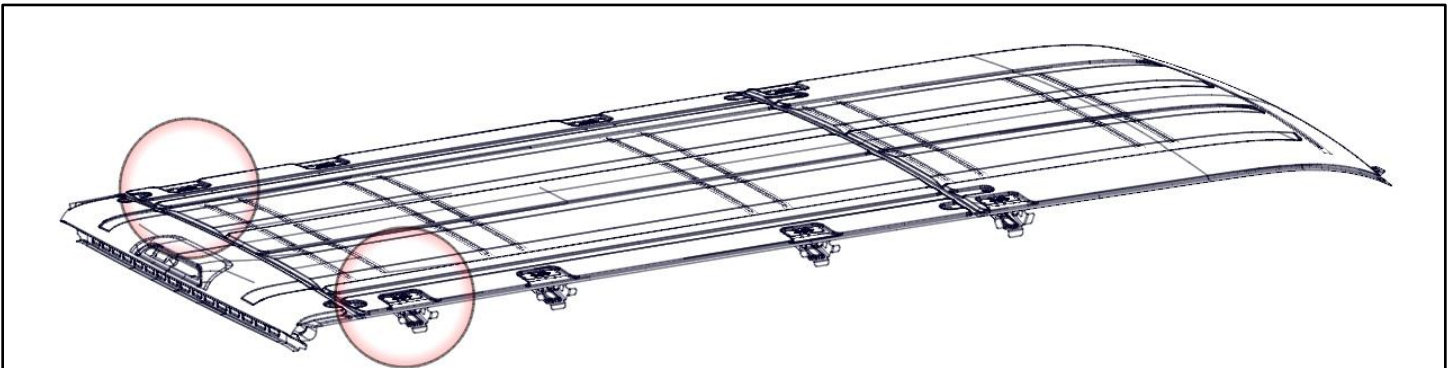

**\*\* Place sealant around the exposed holes in the roof of the van under the rubber pads to ensure no water can leak into the cabin of the van. \*\***

- Attach the rear mount bracket using M8 x 30mm flat head bolts. Place two rubber pads between the bracket and the roof of the van. The bracket should be parallel with the length of the van and the flange should be to the inside.
- Tighten. (Passenger side shown)

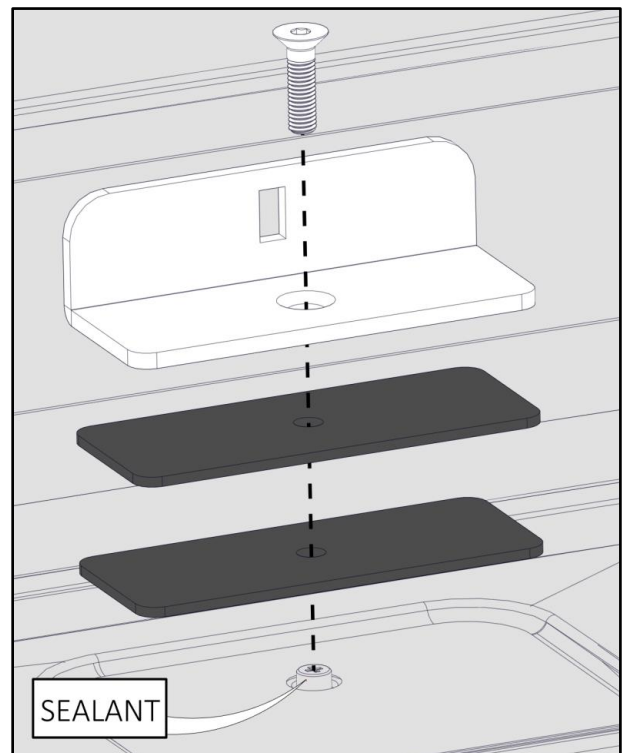

## Step 2A – Front Mount on 130” Wheel Base (Low/Mid Roof)

- Locate the other threaded inserts at the front of the van. Remove plugs.

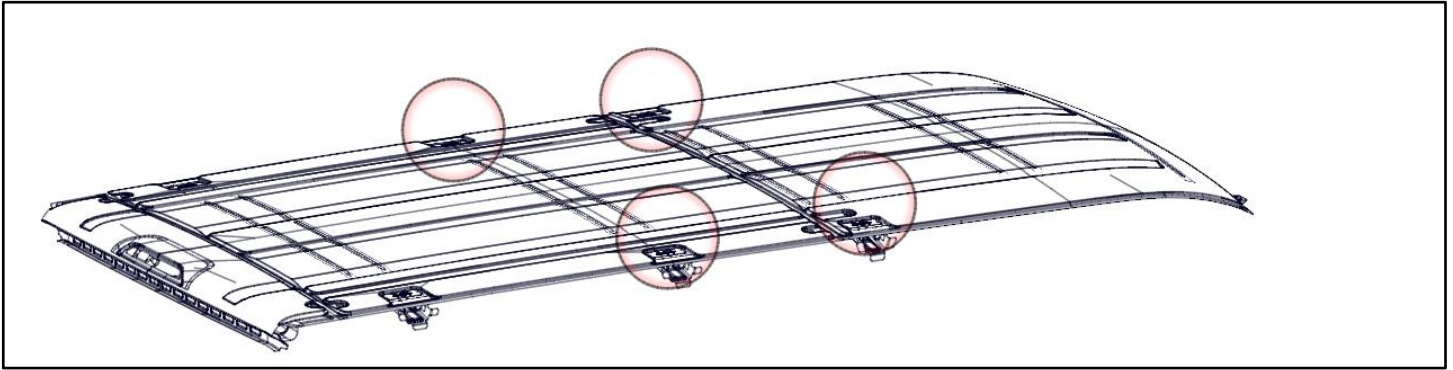

**\*\* Place sealant around the exposed holes in the roof of the van under the rubber pads to ensure no water can leak into the cabin of the van. \*\***

- Place the long mount rail with the tall flange towards the center of the van on top of the rubber pad and black nylon block.
- Bolt through farthest rear slot in the rail and the corresponding front slot using M8 x 45mm bolts with lock washers and flat washers.
- The rail should be offset to the front of the van.

(Passenger side, rear most mount on the rail shown)

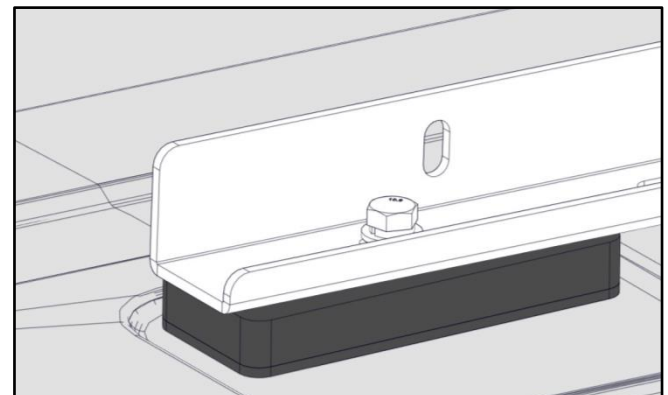
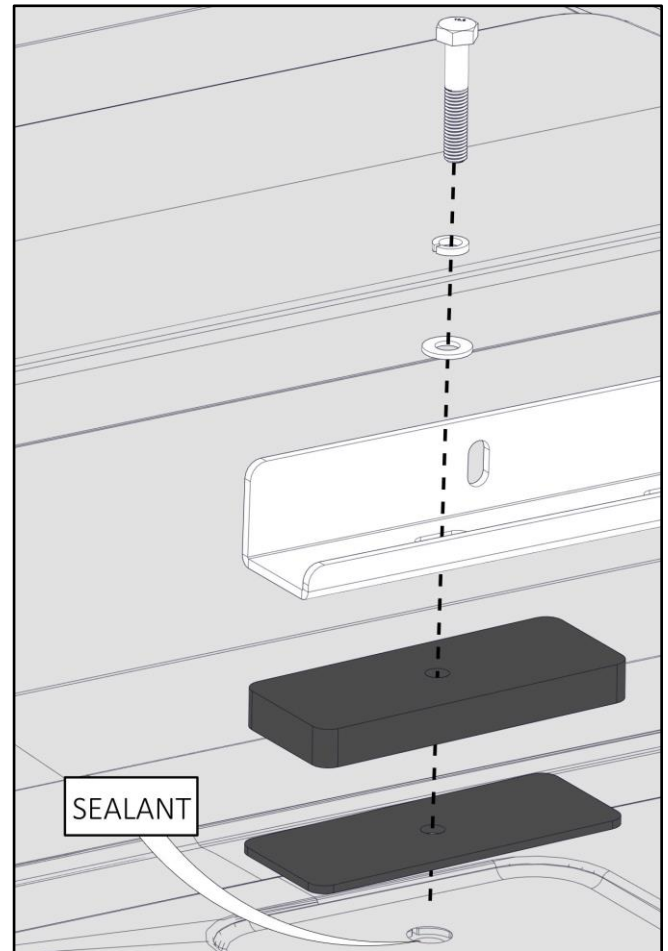



- Passenger side shown, repeat on driver side.
- Snug tighten.

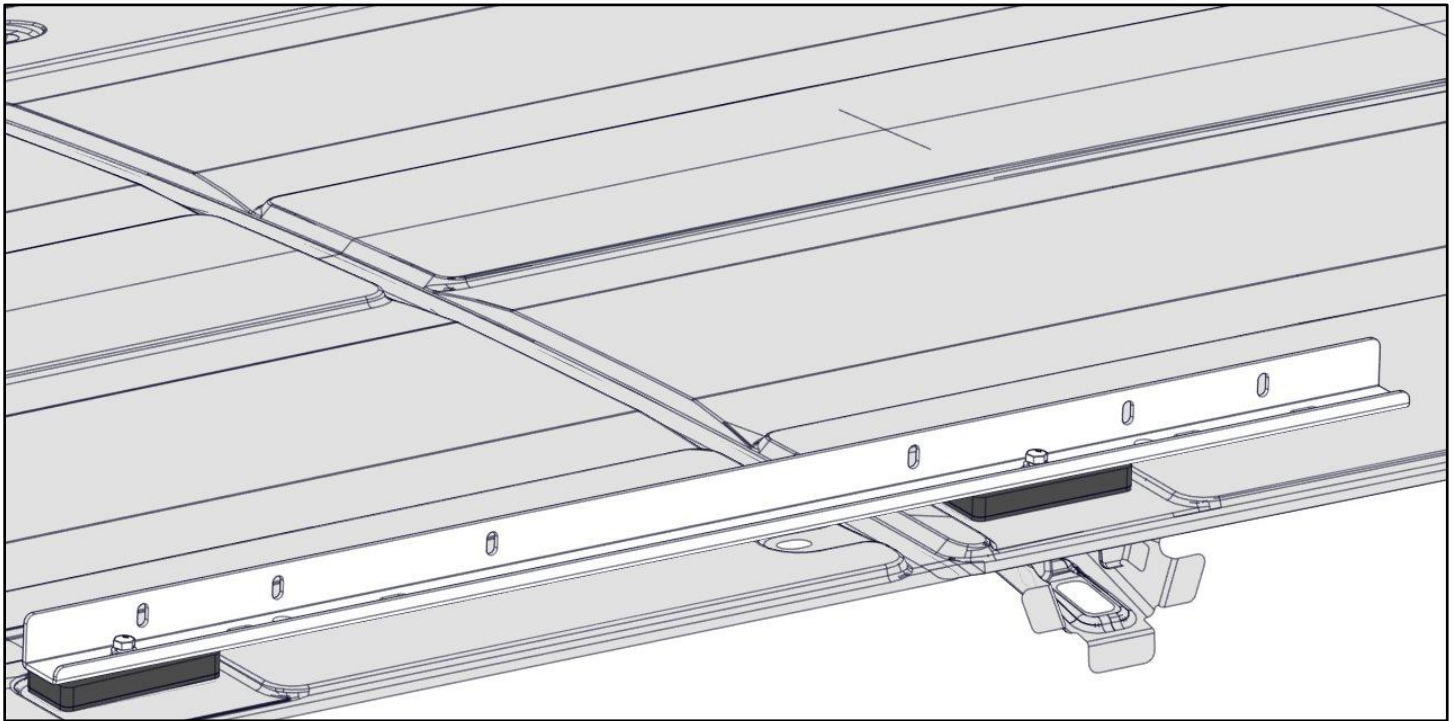
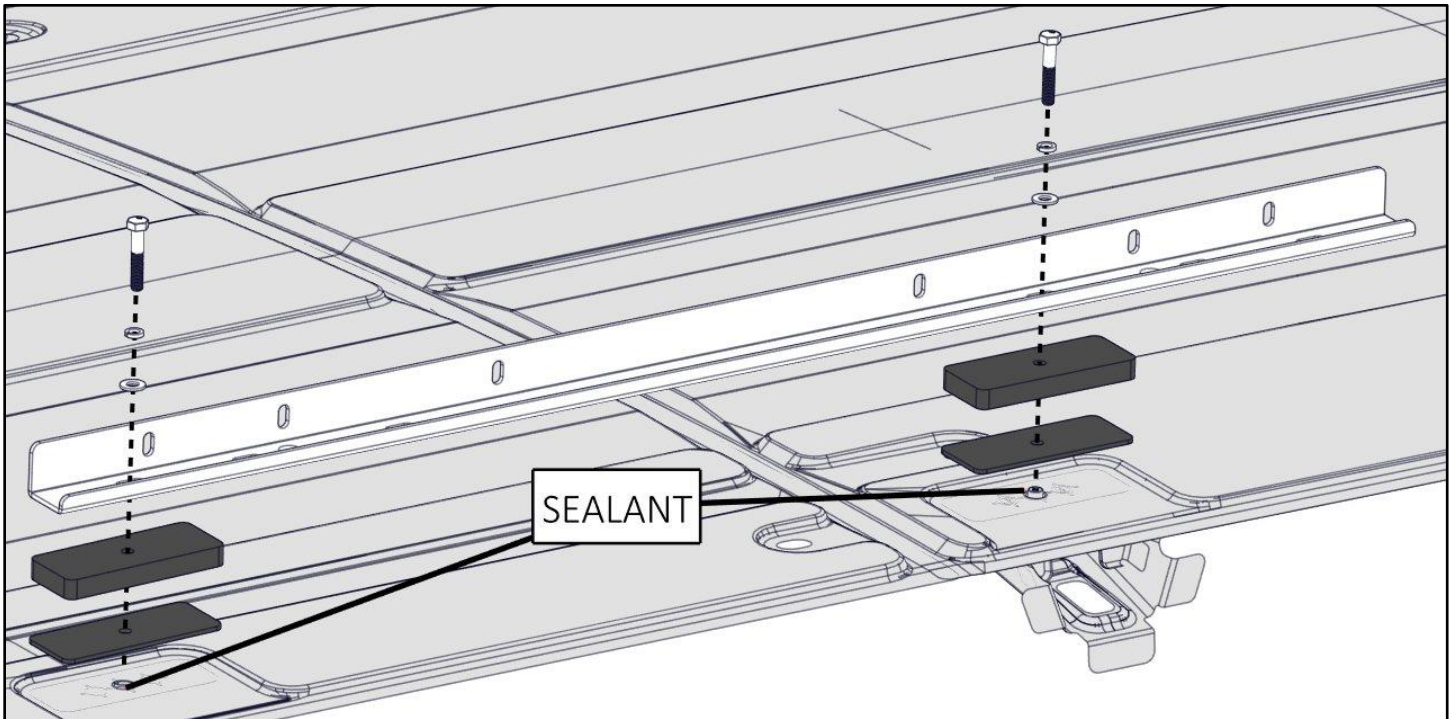

## Step 2B – Front Mount on 148” Wheel Base (Low/Mid/High Roof excluding Extended)

- Locate the other threaded inserts at the front of the van. Remove plugs.

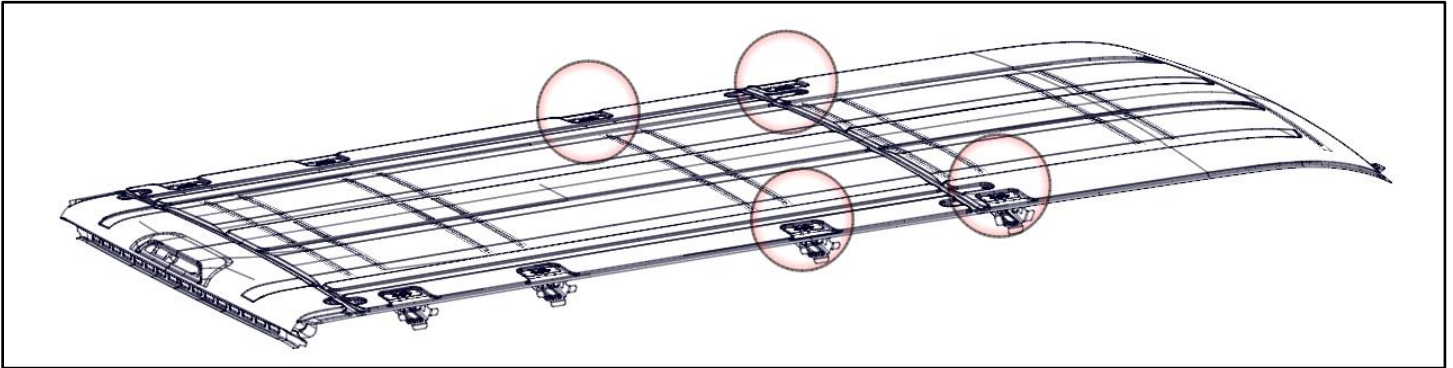

**\*\* Place sealant around the exposed holes in the roof of the van under the rubber pads to ensure no water can leak into the cabin of the van. \*\***

- Place the mount rail with the tall flange towards center of the van on top of the rubber pad and black nylon block.
- Bolt through the farthest rear slot in the mount rail and corresponding front slot in the rail using M8 x 45mm bolts with lock washers and flat washers.
- The rail should be offset to the front of the van.

(Passenger side, rear most mount on the rail shown)

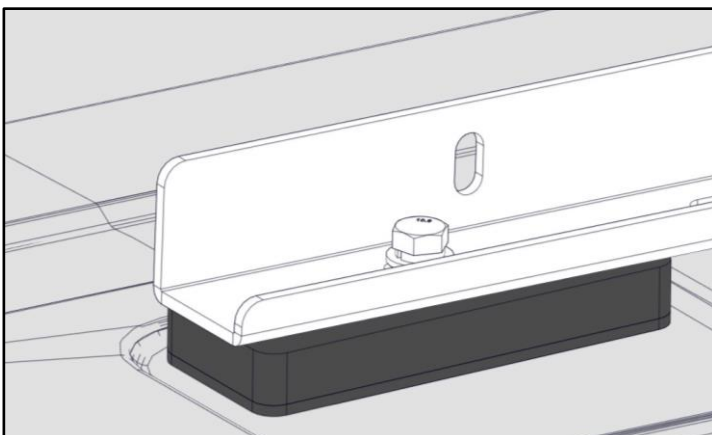
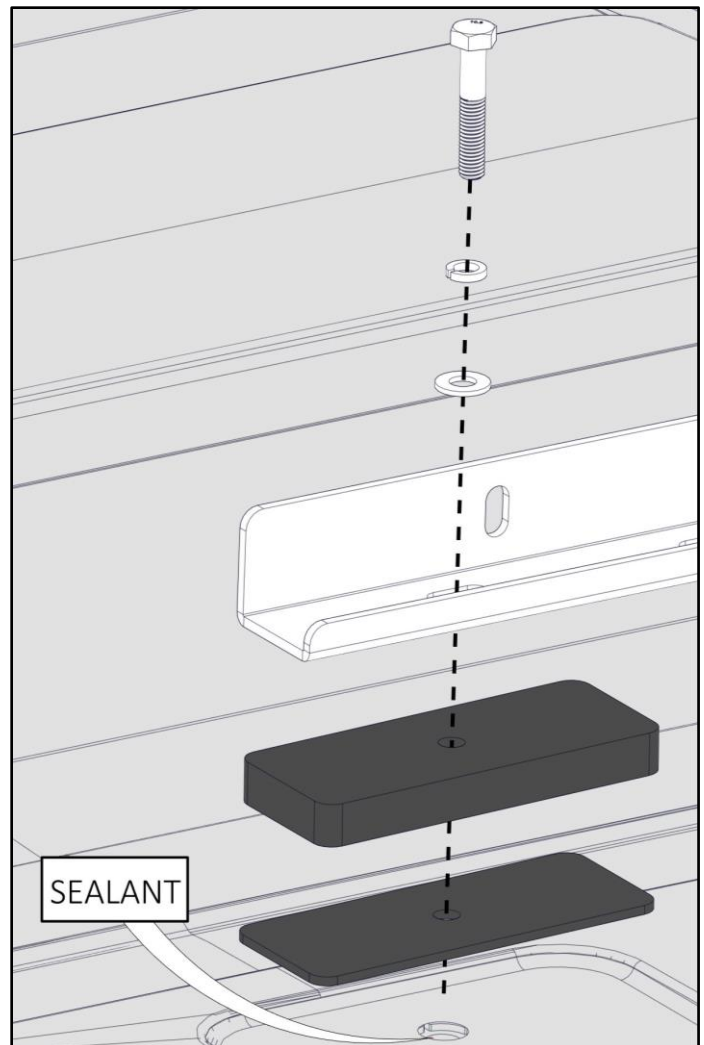



- Passenger side shown, repeat on driver side.
- Snug Tighten.

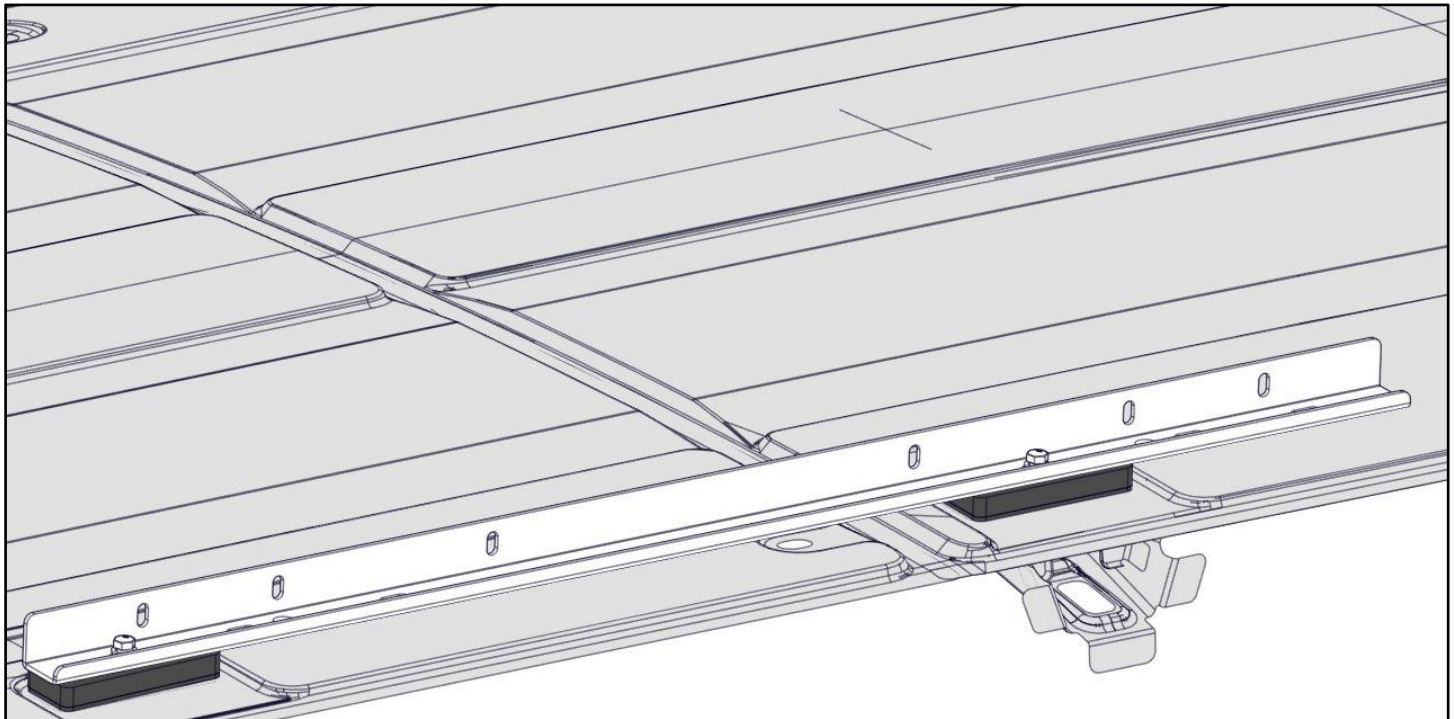
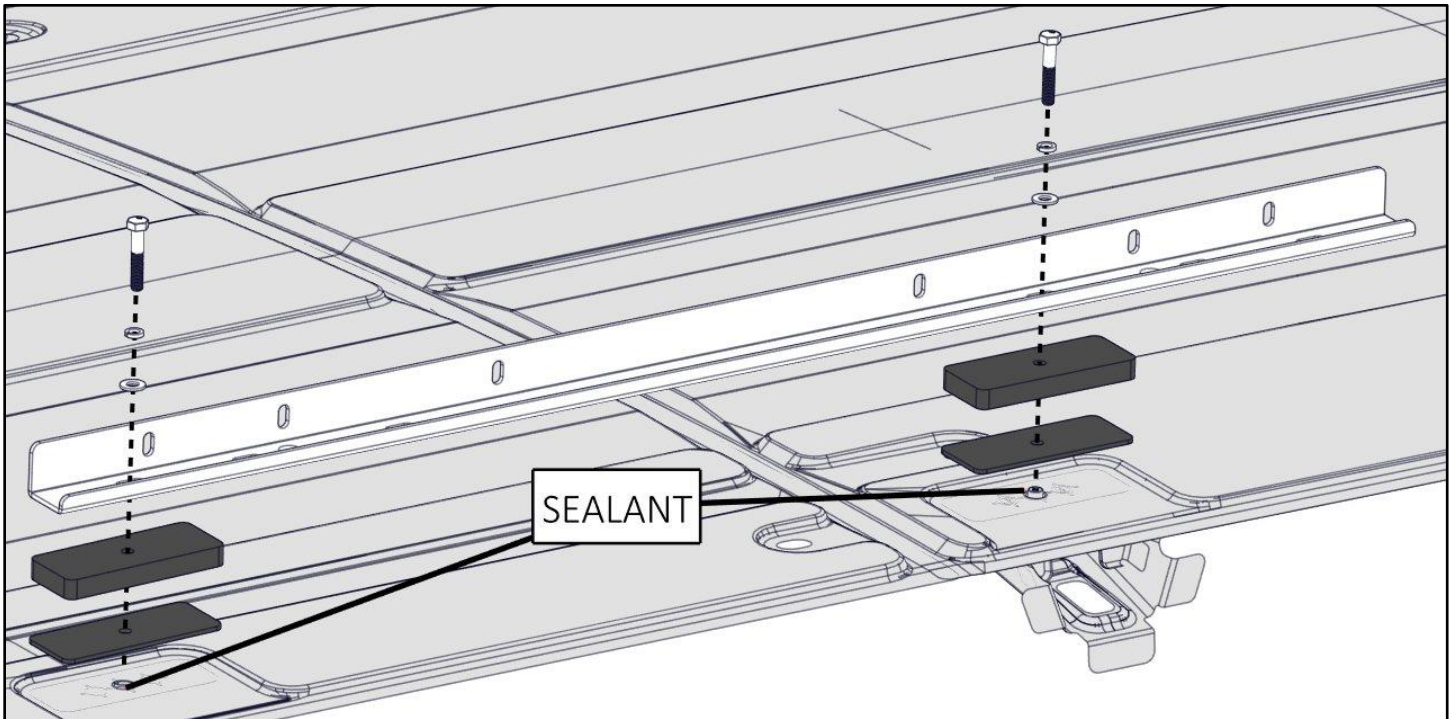

## Transit 148" Wheelbase, High Roof, Extended

### Step 3A - Extended - Rear Foot Mounting

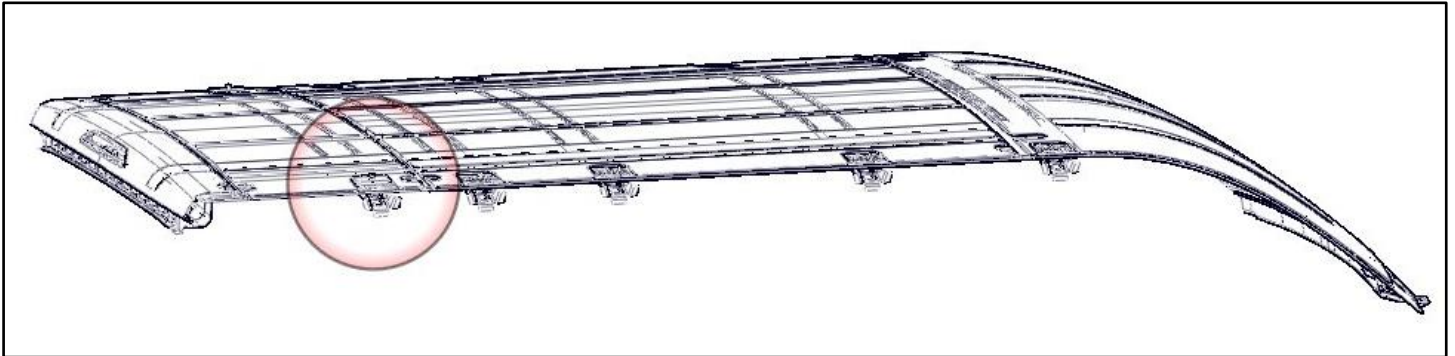

**\*\* Place sealant around the exposed holes in the roof of the van under the rubber pads to ensure no water can leak into the cabin of the van. \*\***

- Mount rear mount bracket using M8 x 30mm flat head bolts. Place two rubber pads between the bracket and the roof of the van. The bracket should be parallel with the length of the van and the flange should be towards the center as shown.

(Passenger side shown)

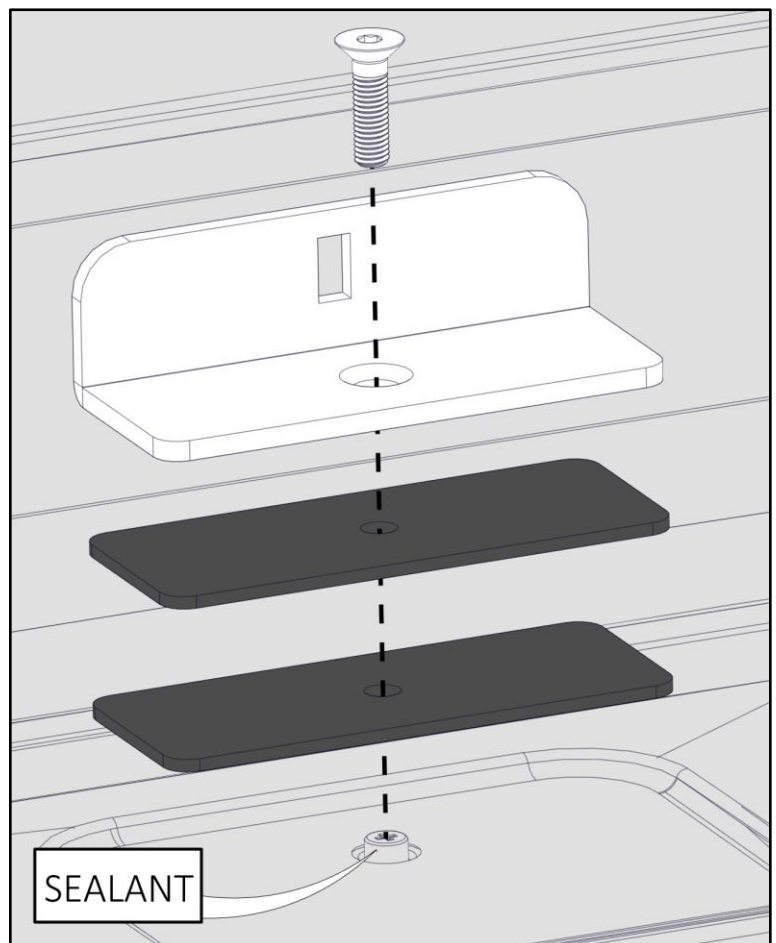

## Step 3B - Extended - Front Mount

- Locate the other two threaded inserts at the front of the van. Remove plugs.

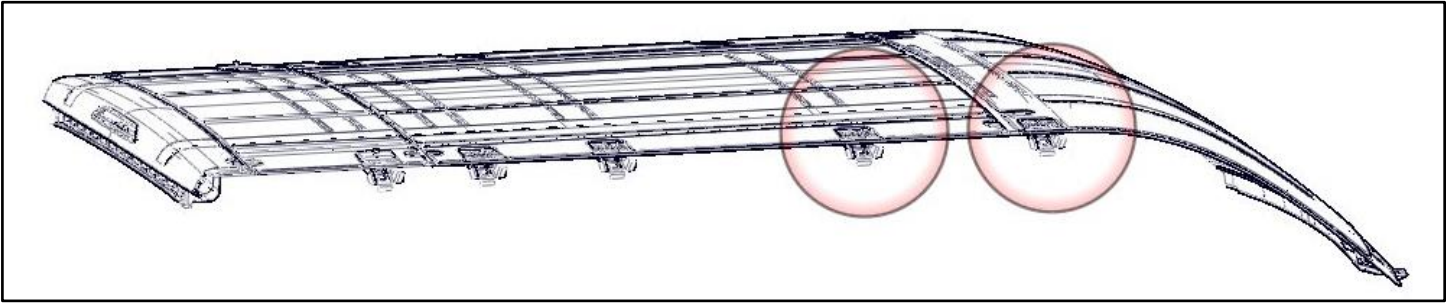

**\*\* Place sealant around the exposed holes in the roof of the van under the rubber pads to ensure no water can leak into the cabin of the van. \*\***

- Place the long mount rail with the tall flange towards the center of the van.
- Bolt through the farthest rear countersunk hole and the 2nd slot from the front using M8 x 45mm bolts with lock washers and flat washers.

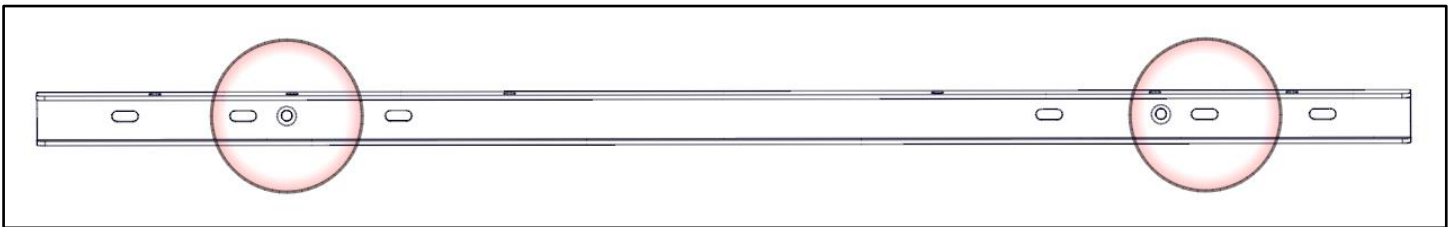

- The picture shown below is the rear most mount on the rail. (through the countersunk hole)
- Passenger side shown, repeat on driver side.
- Snug Tighten.

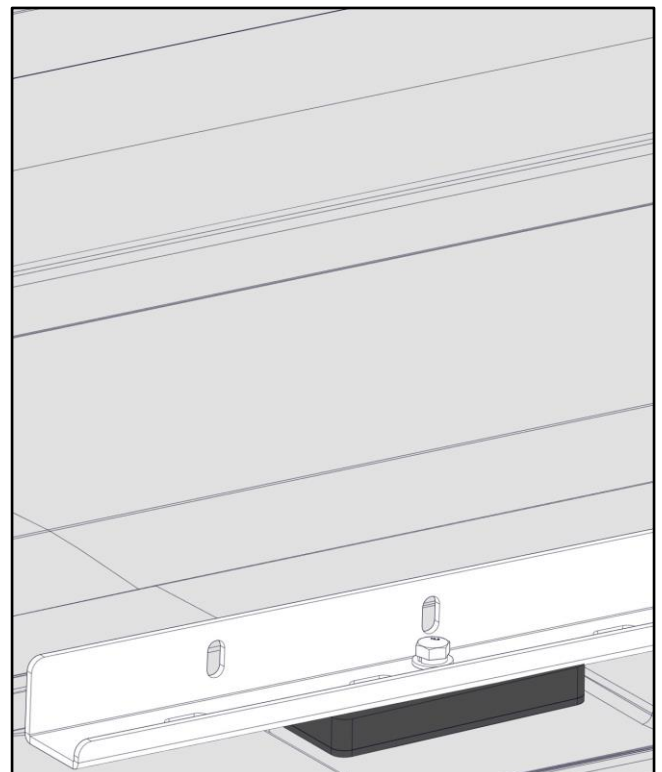
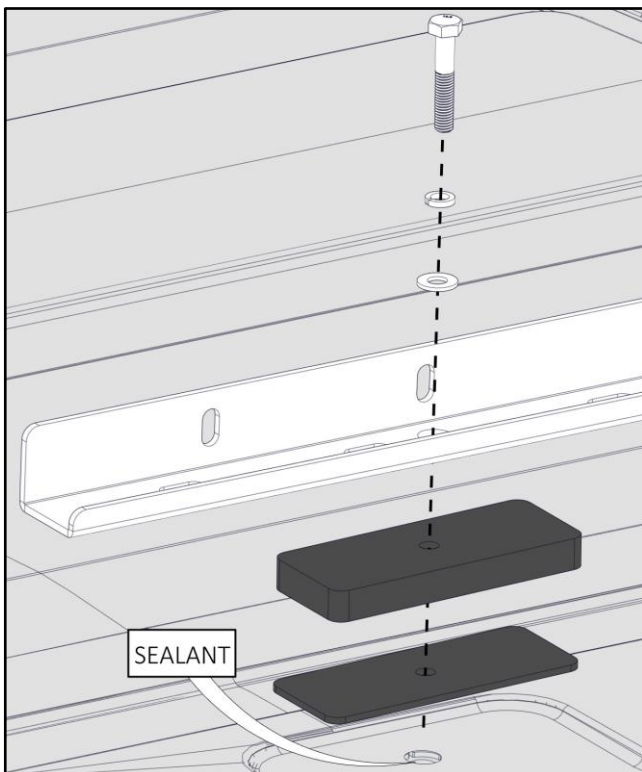



## Step 4 – Install Rear Feet

- Bolt large foot (has a cut out) to the rear mount previously installed using 5/16" x 7/8" hex head bolt, two 5/16" flat washers and a 5/16" nyloc nut. (Passenger side shown without roof and rack for clarity)

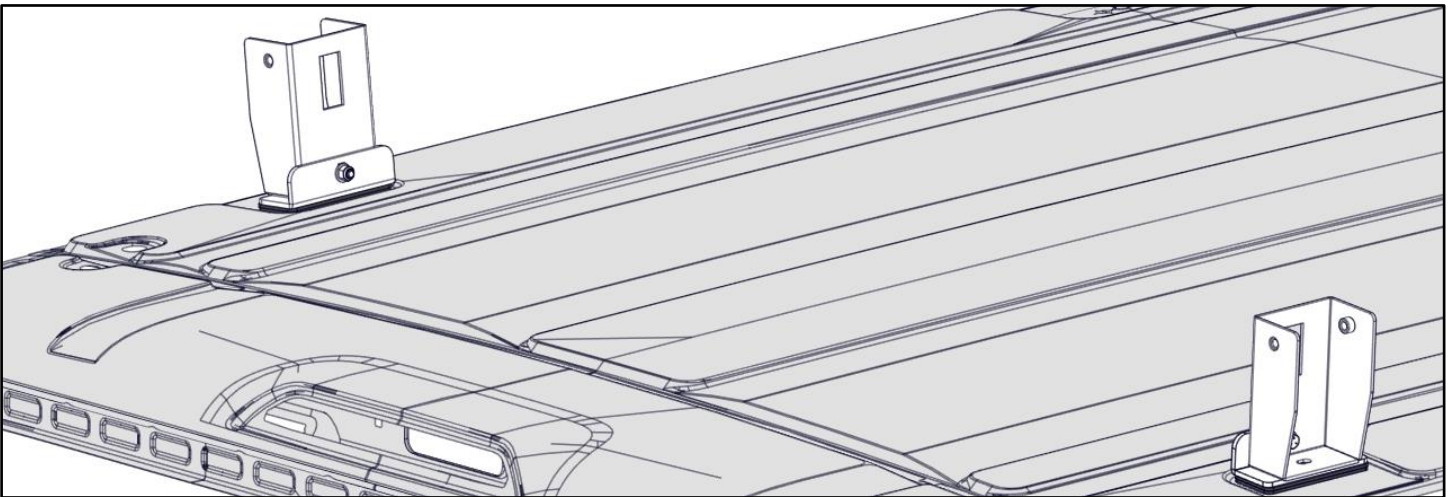
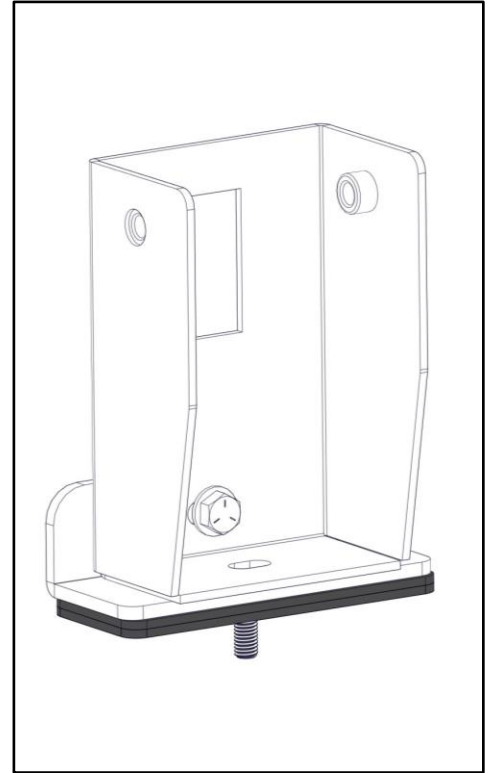
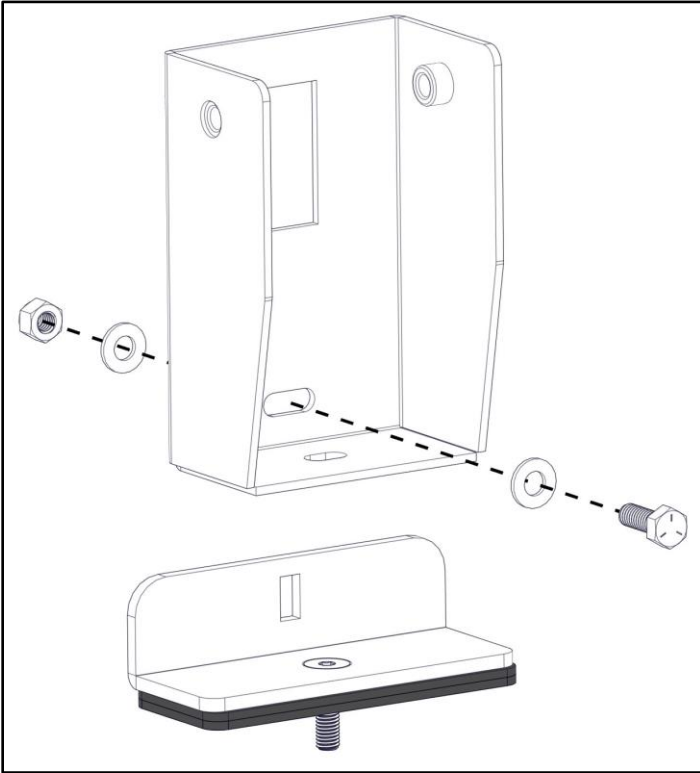

## Step 5 – Install Front Feet

- Mount the tall foot to the previously installed rail using a 5/16" x 7/8" hex head bolt, two 5/16" flat washers and a 5/16" nyloc nut.
- Be sure the distance between the two feet closely matches the distance between the bows on the ladder rack being installed. The slot used on the front rail will vary from the picture below.

Note: One may choose to install the feet on the rack prior to installing onto the vehicle. It is the installers preference.

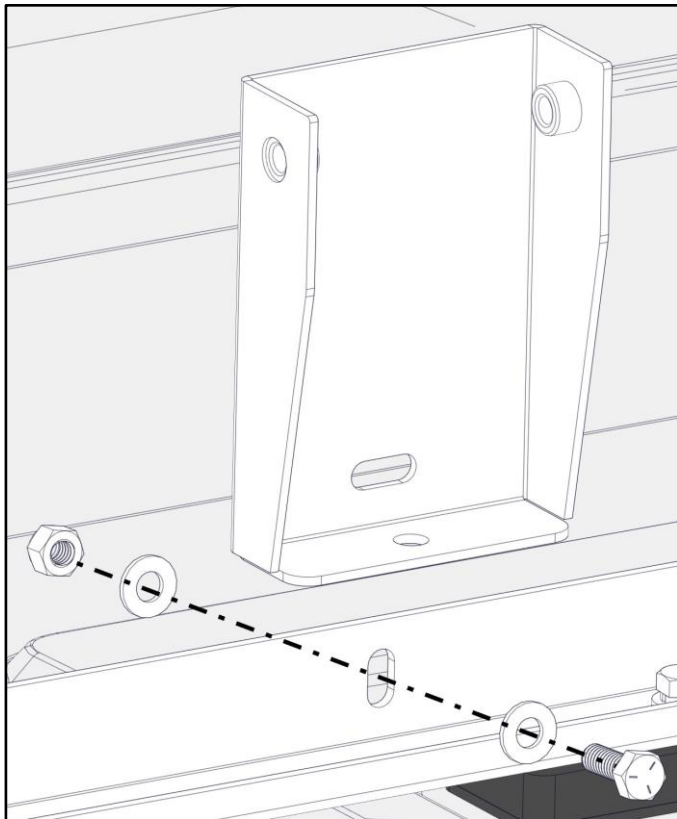
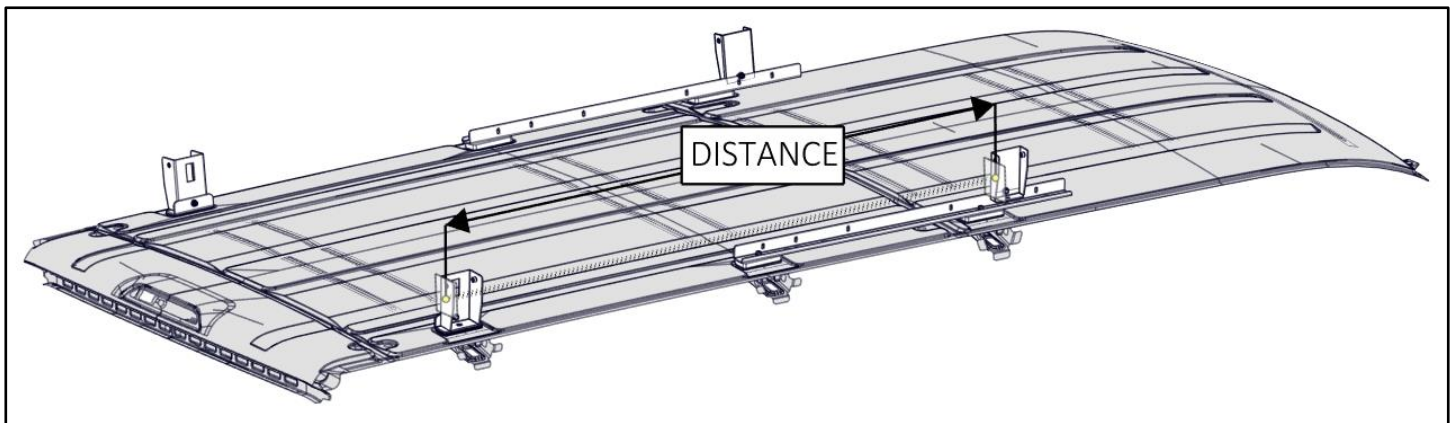



## Step 6 – Feet to Rack

- Place assembled ladder rack on top of the previously installed feet.
- Measure width between the mounts on the van.
- Center the assembled rack on top of the installed feet. Align bow with the same slot on opposite ends.
- Bolt the feet to the bows as shown using 3/8" x 3/4" hex head bolts, 3/8" lock washers and a 3/8" flat washers.

Note: One may choose to install the feet on the rack prior to installing onto the vehicle. It is the installers preference.

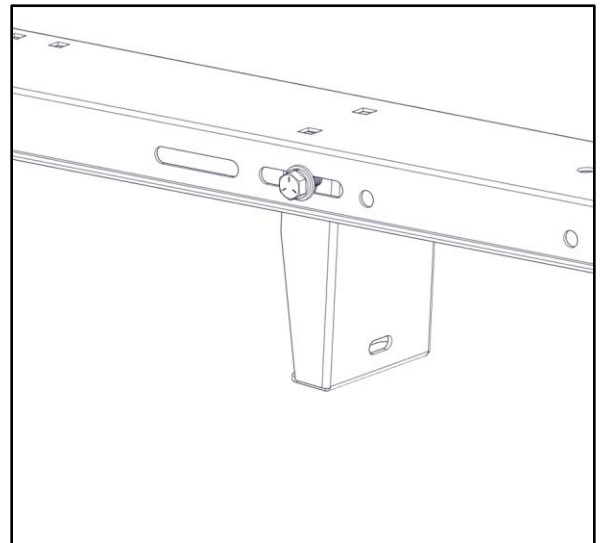
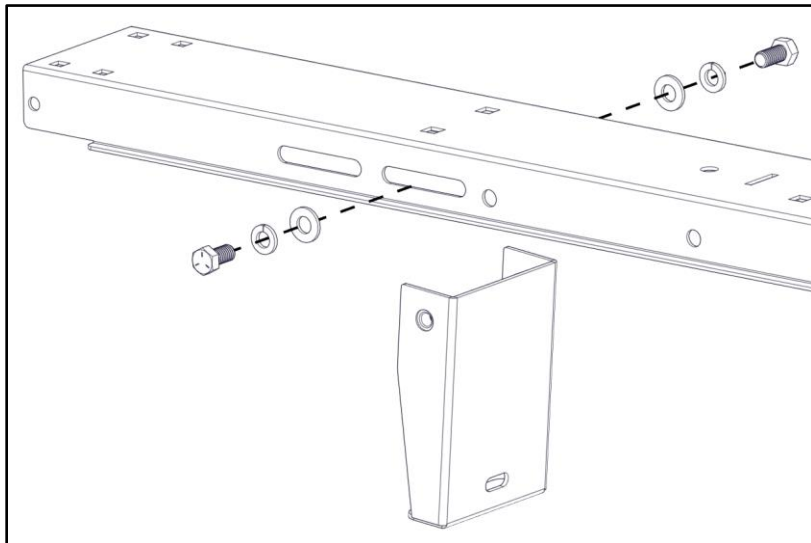
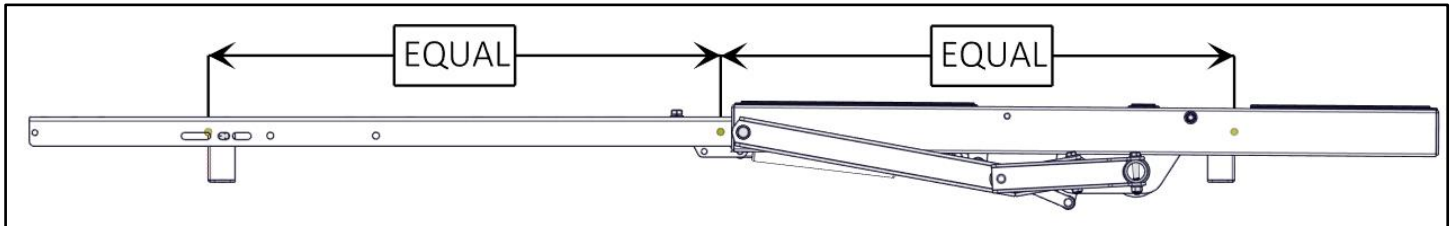
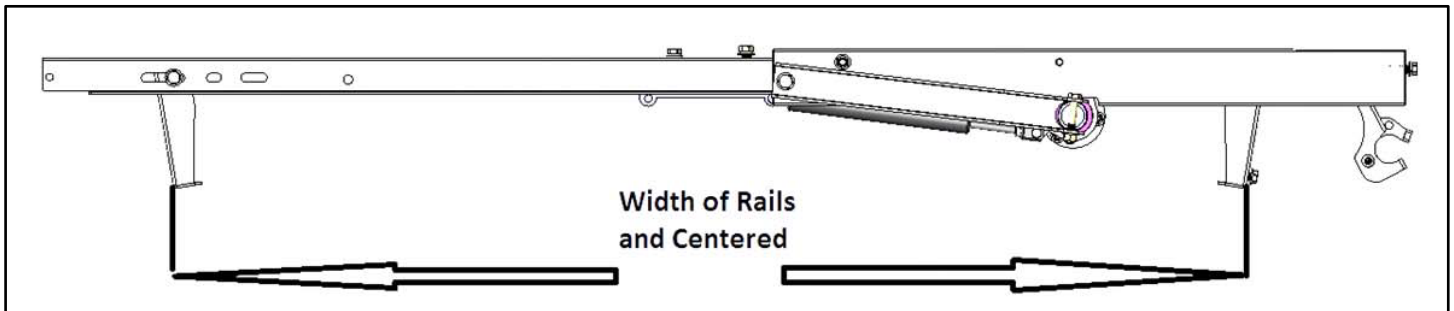

Go back and square the rack.

Ensure all hardware is tight. This includes into the roof, within the rack assembly and the mounting of the rack to roof mounts.

Your installation is complete.

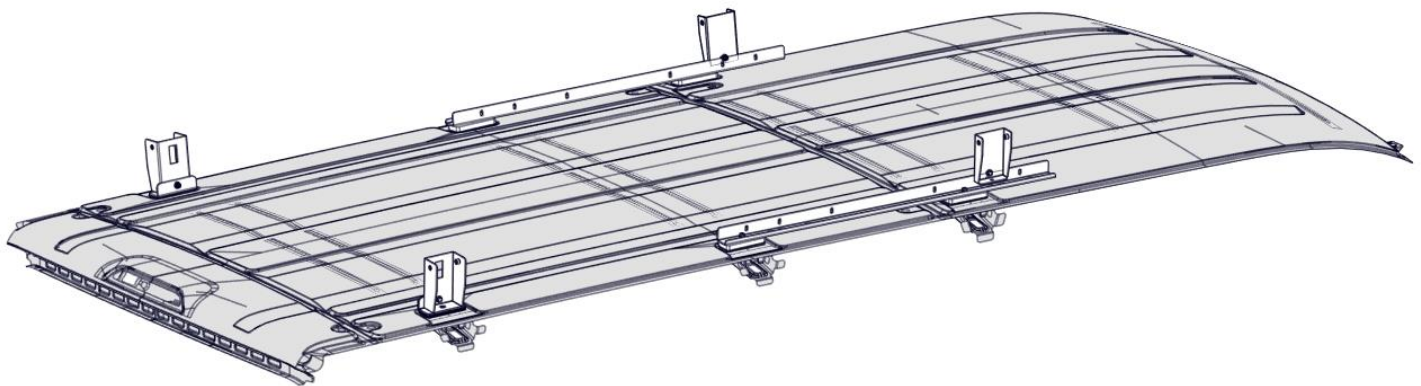

---

# KARGO MASTER®

**WE PUT EVERYTHING WITHIN REACH.**

---

## Installation Guide

---

### 4A92L

---

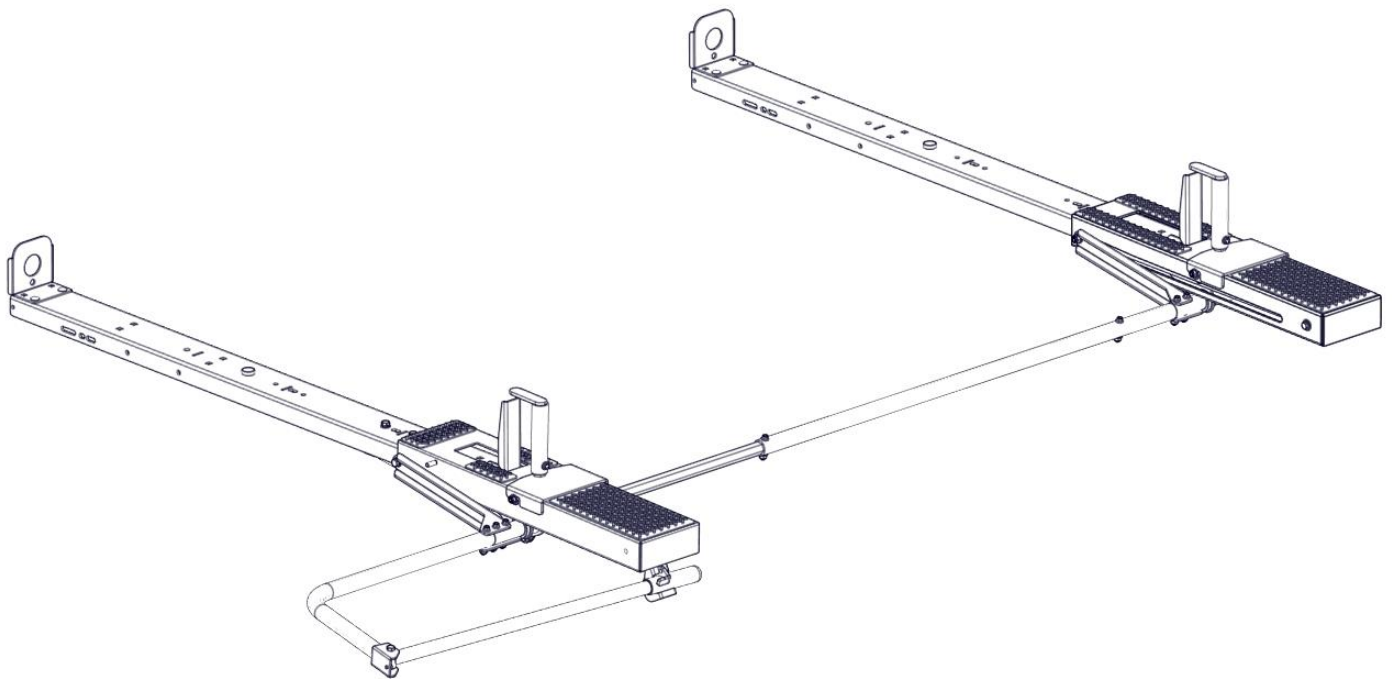

---

\*PLEASE READ ALL INSTRUCTIONS AND WARNINGS PRIOR TO ASSEMBLING,  
INSTALLING, AND USING THIS PRODUCT\*

---

### Warning



Always check for wires, fuel tanks and lines, brake lines and other important vehicle functionality items prior to drilling and installing all products.

---

### Tools Needed





5/16" Wrench and Socket	3/8" Wrench and Socket
1/2" Wrench and Socket	9/16" Wrench and Socket
Tape Measure	

---

### Before You Begin

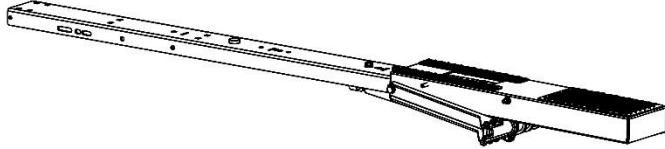
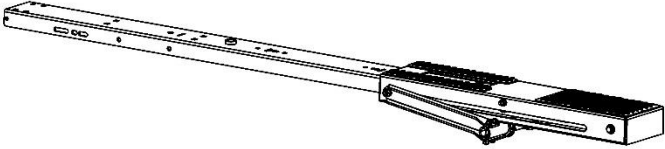
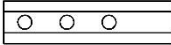
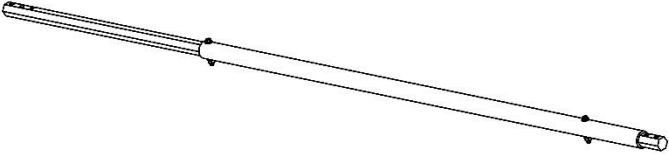
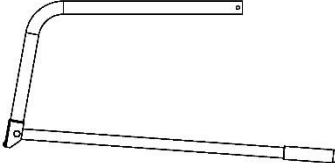

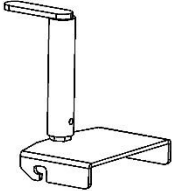
- Read all instructions.
  - Have mount kit installed on vehicle.
  - Front Bow has slot in ladder pan.
  - NEVER EXCEED MANUFACTURERS ROOF WEIGHT RATING.
-

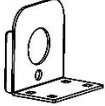
Parts

ITEM NO.		DESCRIPTION	QTY.
A		REAR BOW	1
B		FRONT BOW	1
C		3-HOLE HEX	1
D		HEX TUBE ASM	1
E		HANDLE ASM	1
F		LATCH ASM	1
G		LADDER HOOK	2
H		LADDER STOP	2
J		LOAD PLATE	2
		HARDWARE-4A92L	1

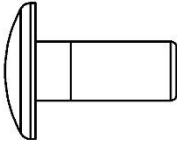

Hardware

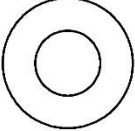
ITEM NO.	TO SCALE	DESCRIPTION	PART NUMBER	QTY.
1		5/16"-18 x 3/4" Carriage Bolt	90185A581	6
2		5/16"-18 Nyloc	95615A160	6
3		5/16" Flat Washer	98023A030	6
			ANTI-SEEZE	1

## Step 1 – Load Plates

- At the end of each bow, opposite from the pan mechanism, bolt load plates (J) using two 5/16" x 3/4" carriage bolts (1), two 5/16" flat washers (2) and two 5/16" nyloc nuts (3) in the orientation shown.
- If installing 4A963, Skip installing load plates.
- Repeat on both bows.
- Snug Tighten, but allow movement.

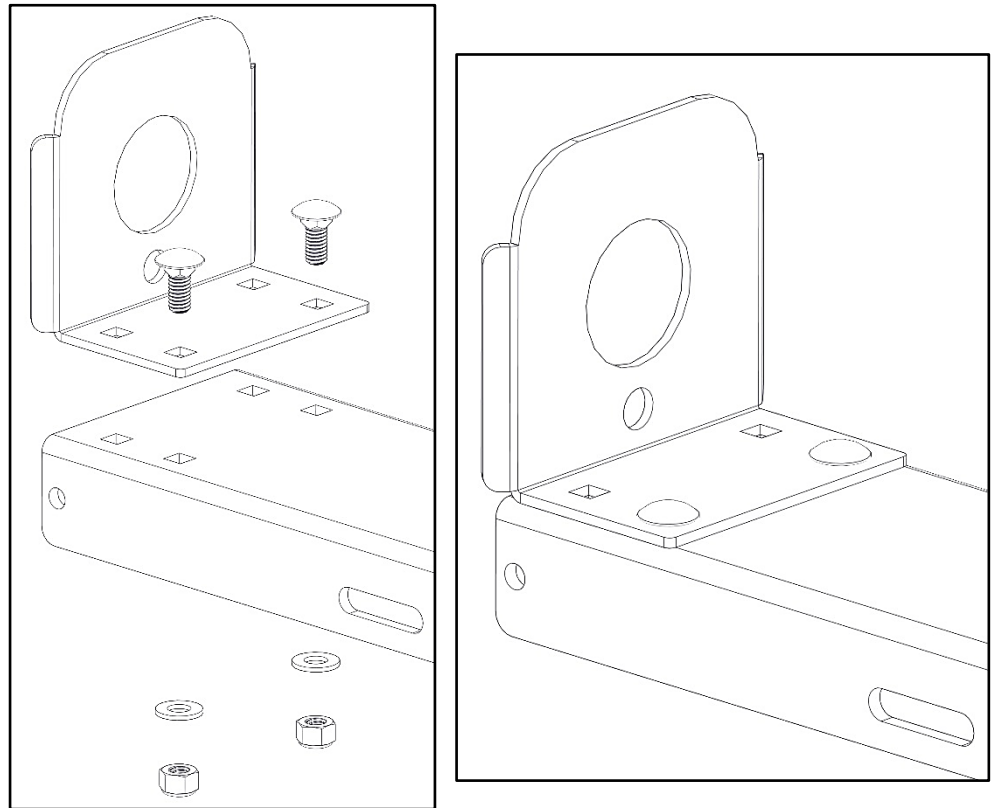

- Determine front and rear bow. The front bow will have a slot in the pan.

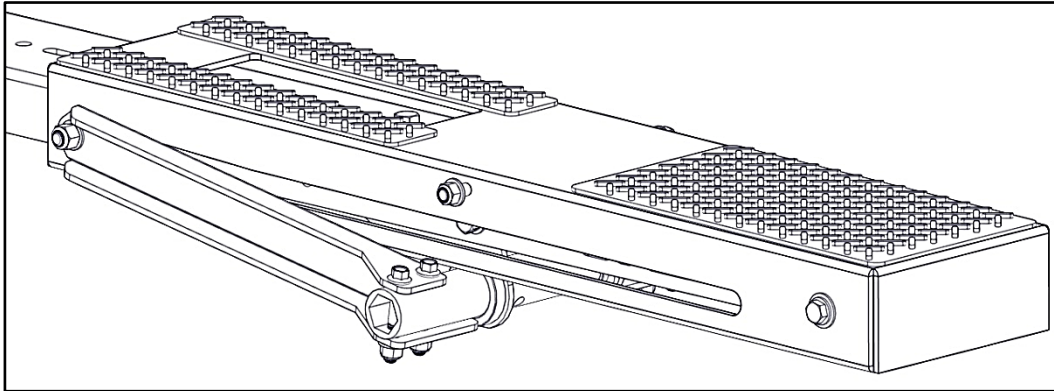

Front Bow

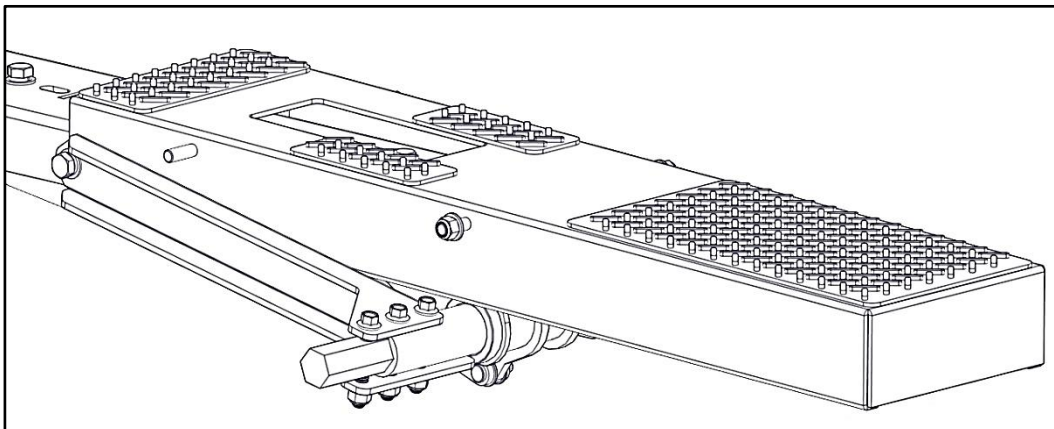

Rear Bow

## Step 2 – Pan Mount

- Set Bow Assy (A&B) on mounting feet as shown. Follow instructions from the mount kit to install on vehicle.
- Place a foam block from the packaging to hold the bow in the up position in order to access the mounting slots.

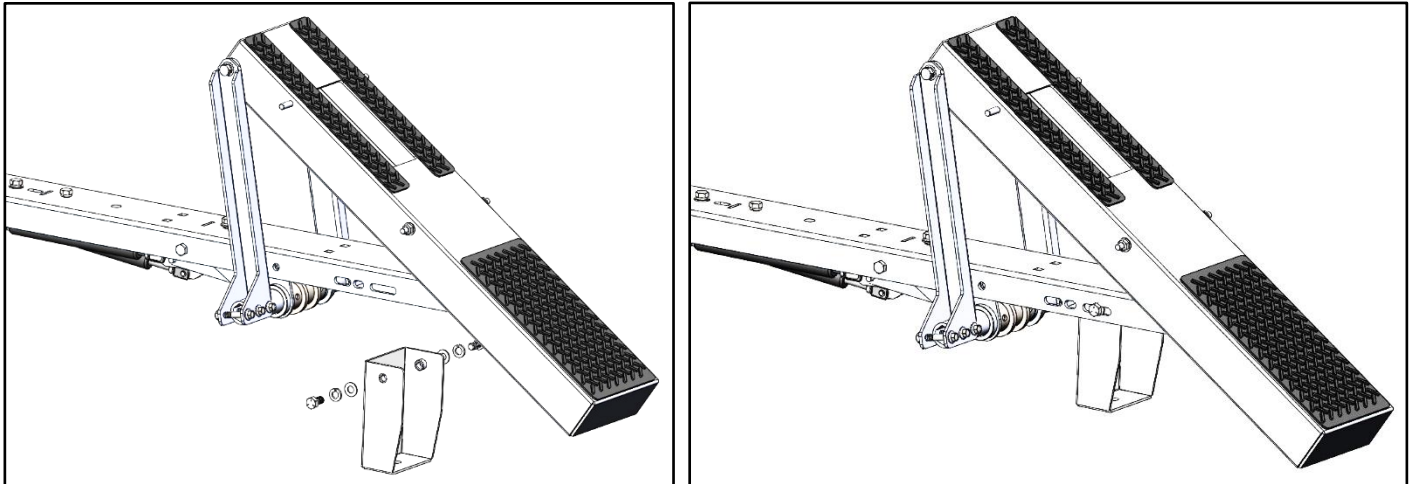

- Use 3/8" x 3/4" hex head bolts with 3/8" lock washers and 3/8" flat washers in order shown.
- Leave loose until the the rack is assembled.
- Repeat on both ends of bow.

## Step 3 – Determine Hex Tube Length

- If the distance between the two bows is greater than 43", use the long hex bar as it comes assembled.

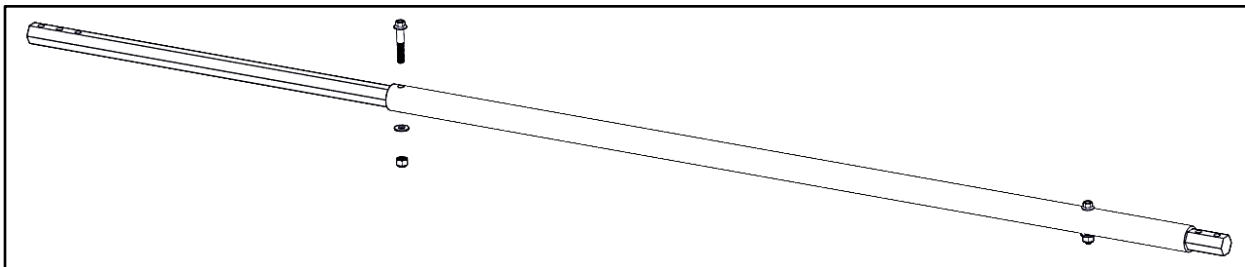

- If the distance between the two bows is approximately 43", remove the long hex tube from the assembly and use the small 3 hole hex tube (C).

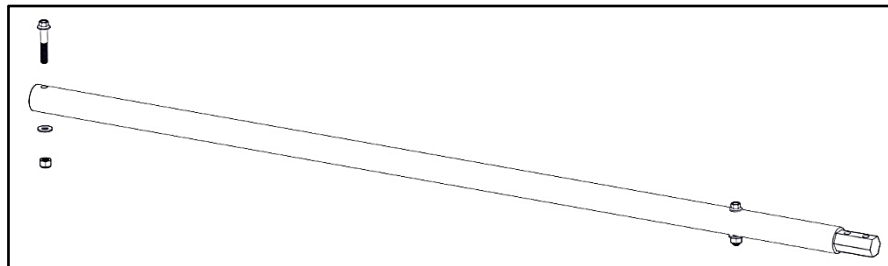

- In either case, remove bolt closest to the end of the hex sleeve that sets length of hex tube assembly, as shown.

## Step 4 – Install Hex Tube

- Install hex tube to front pan assembly.
- Use the end of the hex tube assembly with 2 exposed holes to mount into the front pan.

\*Front bow shown\*

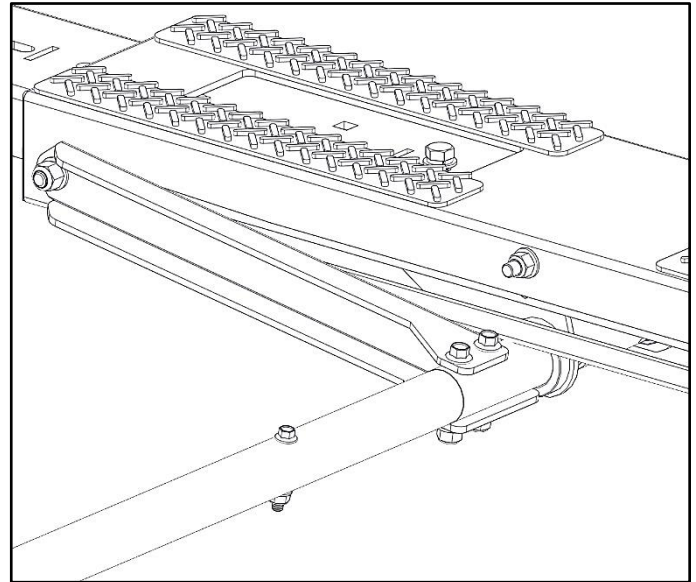
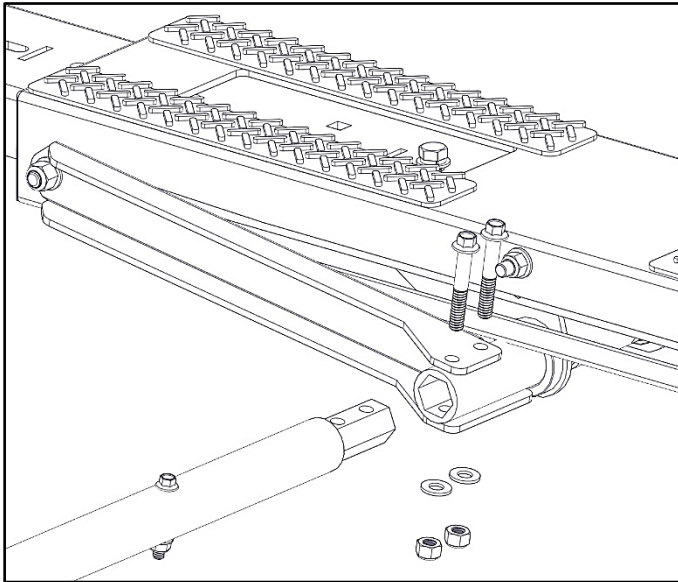

\*Rear bow shown below\*

- Slide hex tube and install on rear pan. (if distance between bows is approximately 43" use small 3 hole hex tube (C), see bottom set of pictures.)
- Bolt to rear pan using included hardware.
- Once bolted to rear pan, adjust hex tube to line holes up with the hex sleeve.
- Once aligned, bolt through both the hex sleeve and the hex tube using bolts from step 3.
- TIGHTEN all bolts from both front and rear pans.

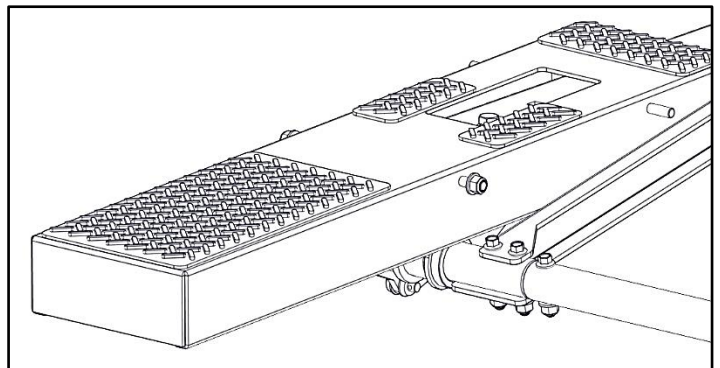
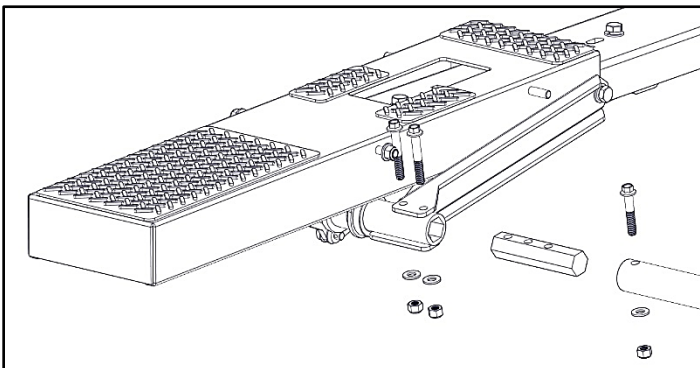
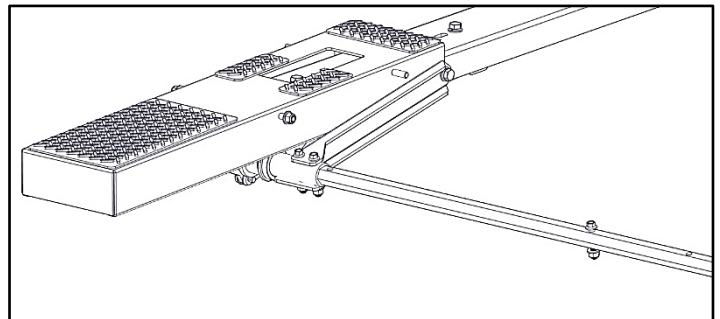
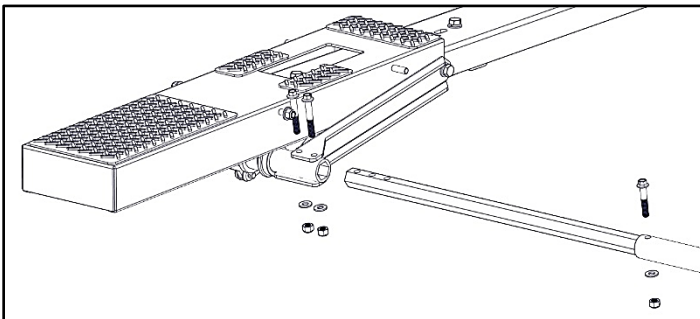

## Step 5 – Install Latch

- Move rear pan assembly out of the way to expose the end of the crossmember.
- Bolt latch assembly (F) to end of crossmember using 5/16" x 3/4" carriage bolts (1), 5/16" flat washers (2) and 5/16" nyloc nuts (3).
- Shown without pan for clarity.
- TIGHTEN

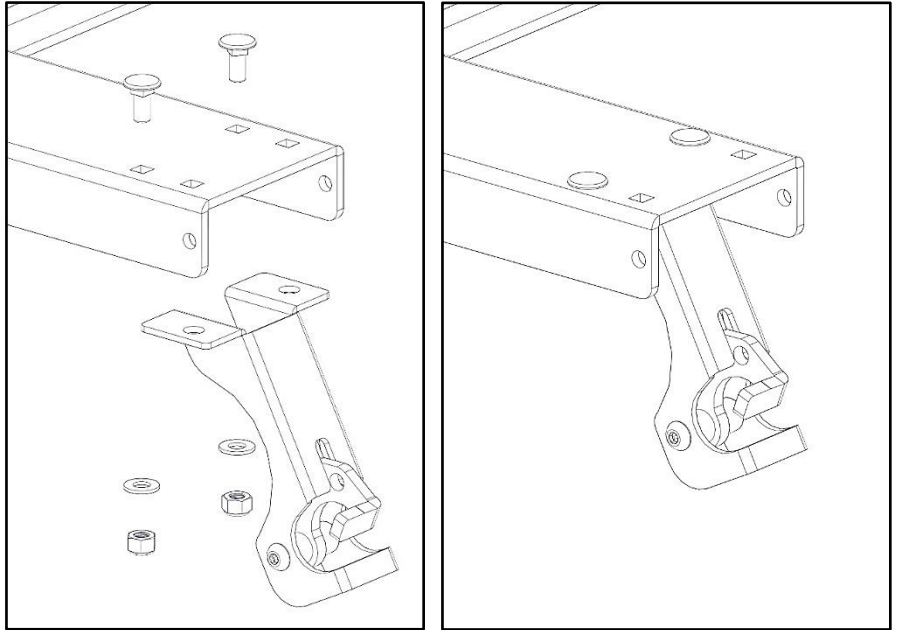

## Step 6 – Install Handle

- Using the hardware in the rear bow to bolt handle (E) into position.
- TIGHTEN

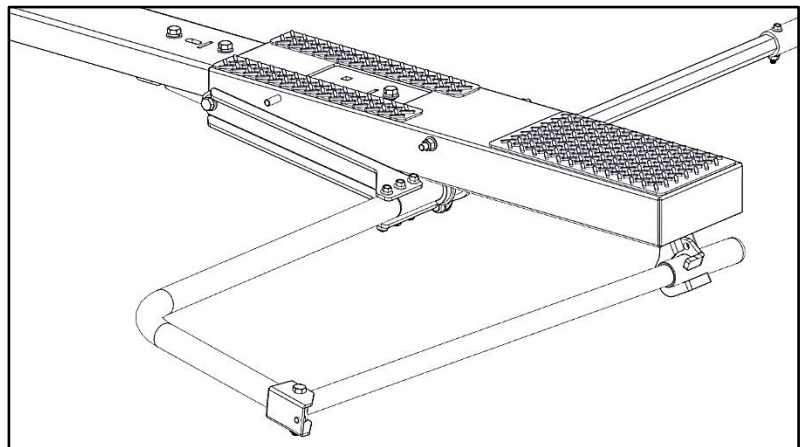
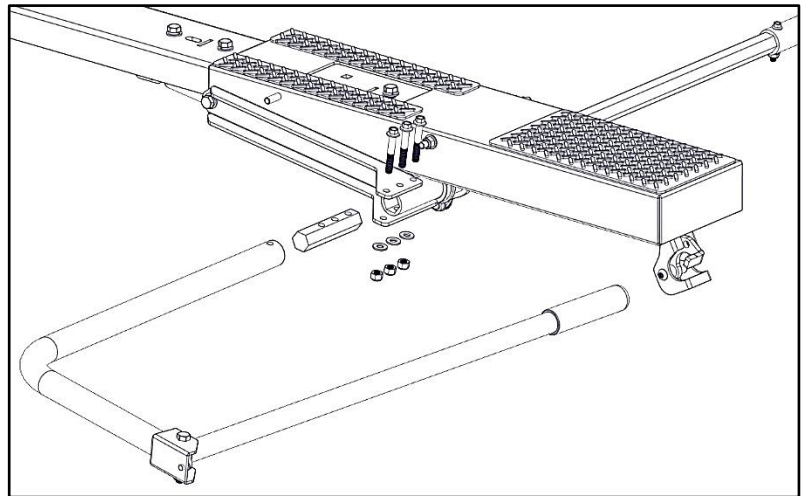



### Step 7 – Ladder Stop

- Using the hardware in both bows, bolt ladder stop (H) in orientation shown. Be sure to place the tab on the ladder stop into the slot on the bow.
- TIGHTEN

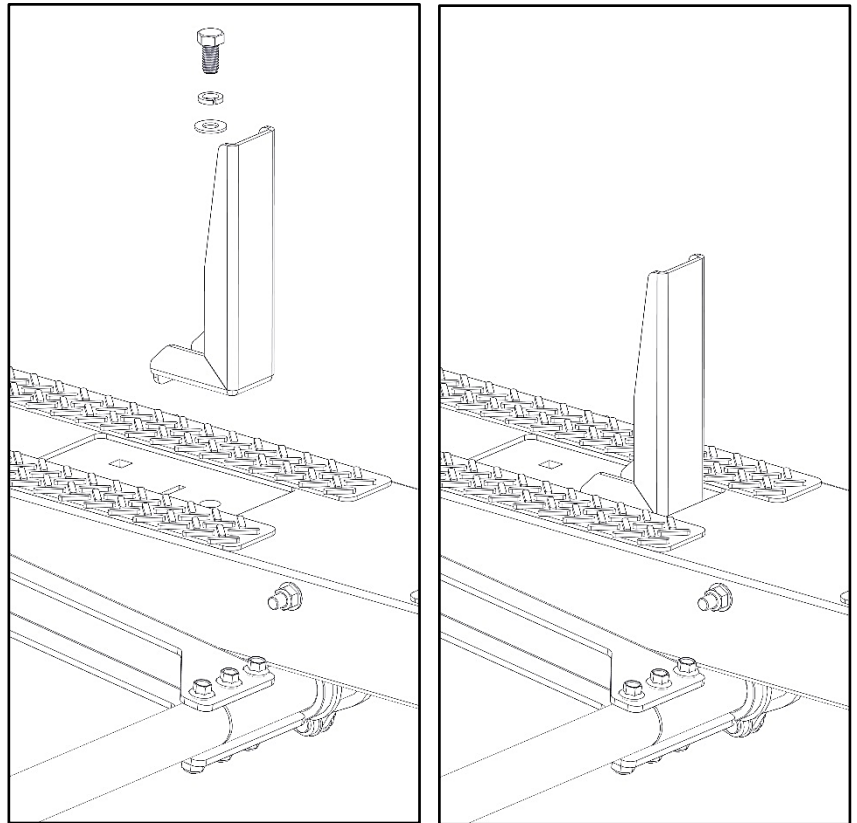

### Step 8 – Ladder Hooks

- Using the hardware and installed pem studs on both bows, loosen nuts and slide ladder hook (G) into place.
- TIGHTEN

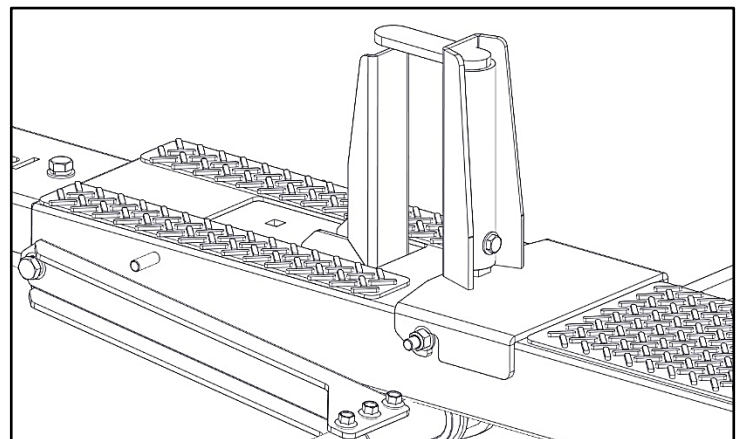
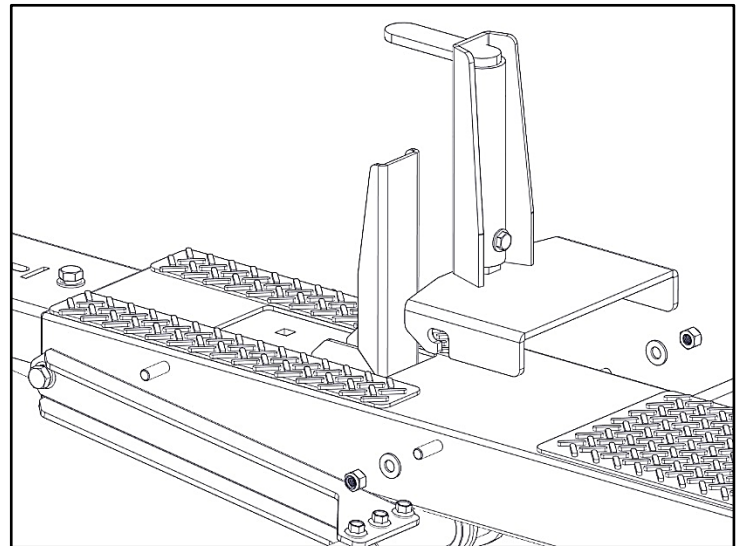

- The ladder hook may be adjusted up or down at 4 different locations.

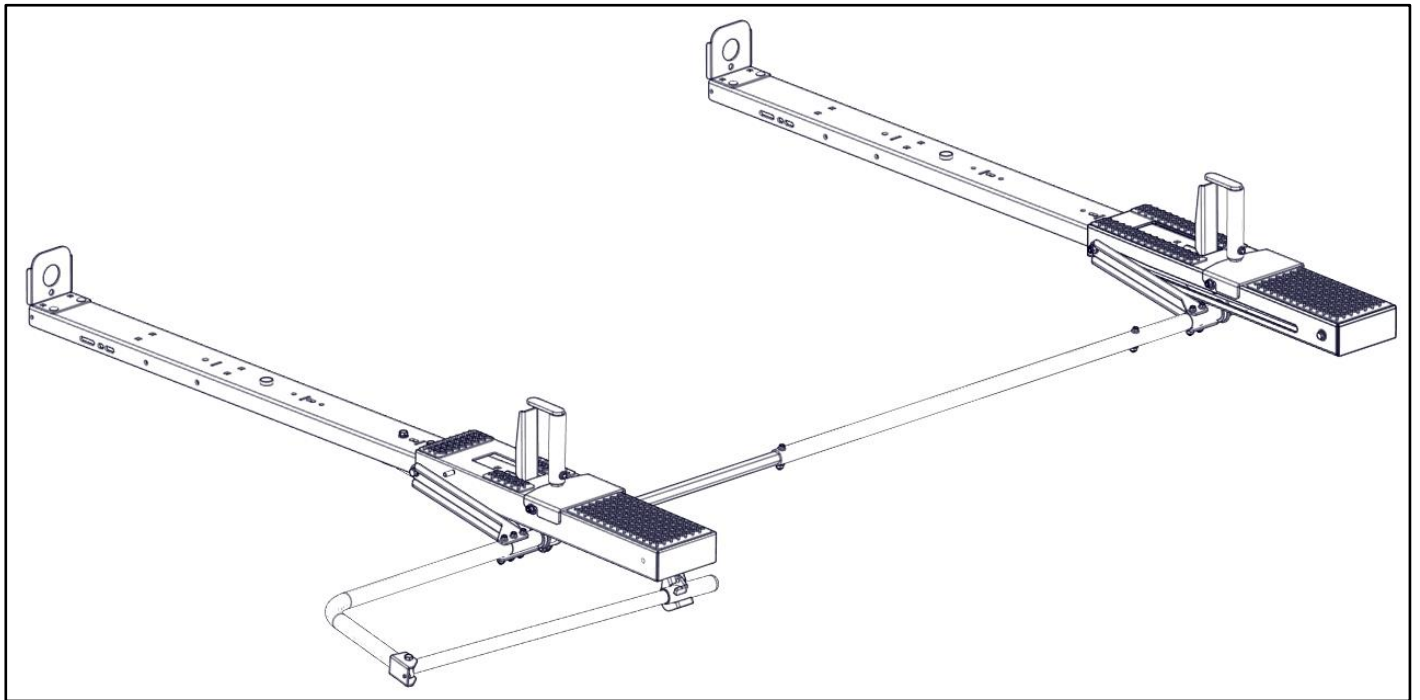
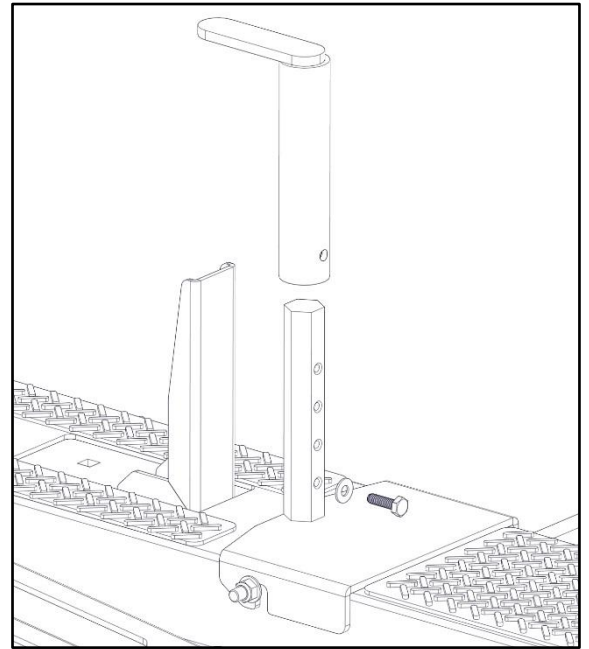

GO BACK AND TIGHTEN ALL BOLTS FROM PREVIOUS STEPS, BE SURE  
HARDWARE IN MOUNTING IS TIGHT.

YOUR INSTALLATION IS NOW COMPLETE

---

# KARGO MASTER®

**WE PUT EVERYTHING WITHIN REACH.**

---

## Instruction Guide

---

4A81L

---

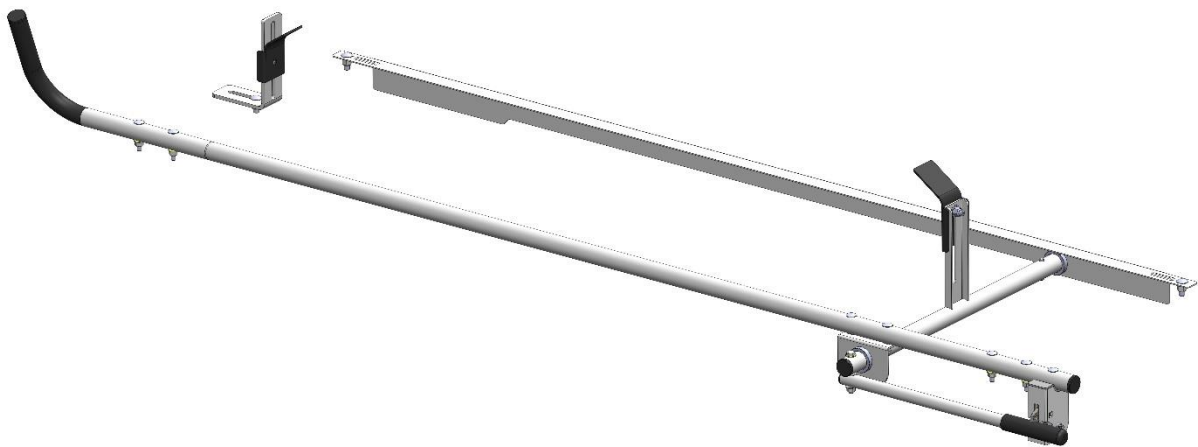

---

**\*PLEASE READ ALL INSTRUCTIONS AND WARNINGS PRIOR TO ASSEMBLING,  
INSTALLING, AND USING THIS PRODUCT\***

---

### Warning



Always check for wires, fuel tanks and lines, brake lines and other important vehicle functionality items prior to drilling and installing all products.

---

### Tools Needed





9/16" Socket and Wrench	1/2" Socket and Wrench
-------------------------	------------------------

---

### Before You Begin

- Read all instructions.
  - **DO NOT EXCEED MANUFACTURERS WEIGHT CAPACITY FOR ROOF.**
  - This kit is the Driver Side add on ONLY.
  - **BE SURE TO ADJUST LADDER CLAMPS ACCORDINGLY TO FIRMLY SECURE LADDER TO RACK.**
-

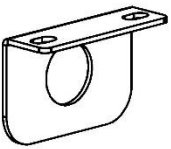
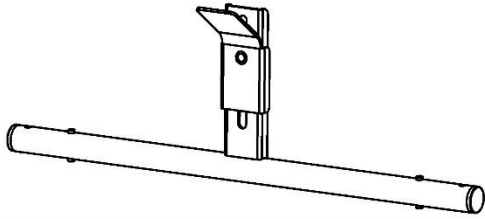
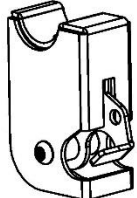
Parts

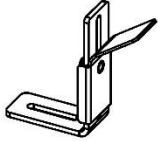
ITEM NO.		PART NUMBER	DESCRIPTION	QTY.
A		4A800-00-003-R3-L	Clamp and Lock L Bracket	1
B		4A800-50-001-R3	Side Tube	1
C		4A800-50-002-R2-L	Side Hook	1
D		11-03027A	Angle BRK	1
E		4A800-30	Clamp Tube	1
F		4A800-20	Latch Assy.	1
G		4A800-40	Handle	1
H		4A800-60	Ladder Stop Assembly	1
		18-4A81L	Hardware	1

Assembly Hardware (18-4A81L)

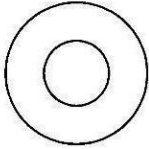
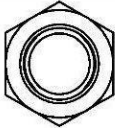
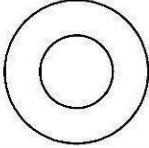
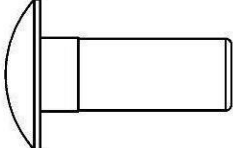
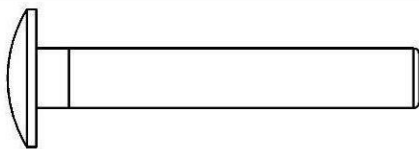
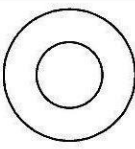
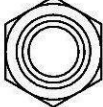
ITEM NO.	TO SCALE	PART NUMBER	DESCRIPTION	QTY.
1		90295A160	.06x.34x.75 Nylon Washer	1
2		.375-16 NYLOC	3/8-16 Nyloc Nut	3
3		.375 FLAT WASHER	3/8 Flat Washer	3
4		.375-16 x 1 Carriage	3/8-16x1 Carriage Bolt	3
5		.312-18x2.0 CARRIAGE BOLT	5/16-18x2.0 Carriage Bolt	7
6		96659A107	5/16 FLAT WASHER	8
7		91831A030	5/16 NYLOC	8

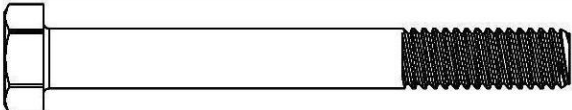
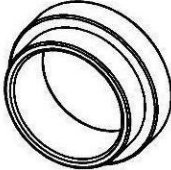
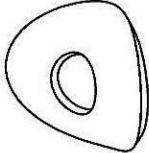
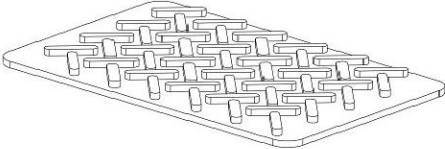
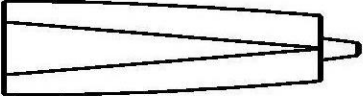

Assembly Hardware (18-4A81L) Continued

8		.312-18 X 2.75 HEX BOLT	5/16-18x2 3/4 Hex Bolt	1
9		40800-10-007	PLASTIC BUSHING  1:2 SCALE	2
10		91844A230	5/16 CONTOUR WASHER	1
11		Extra Rubber Pad	1:2 SCALE	1
		BH-821	Sealant	1

## Step 1 – Remove Ladder Stops

- If havent already done so, remove ladder stops from opposite end of both bows where the clamp and lock is installed.

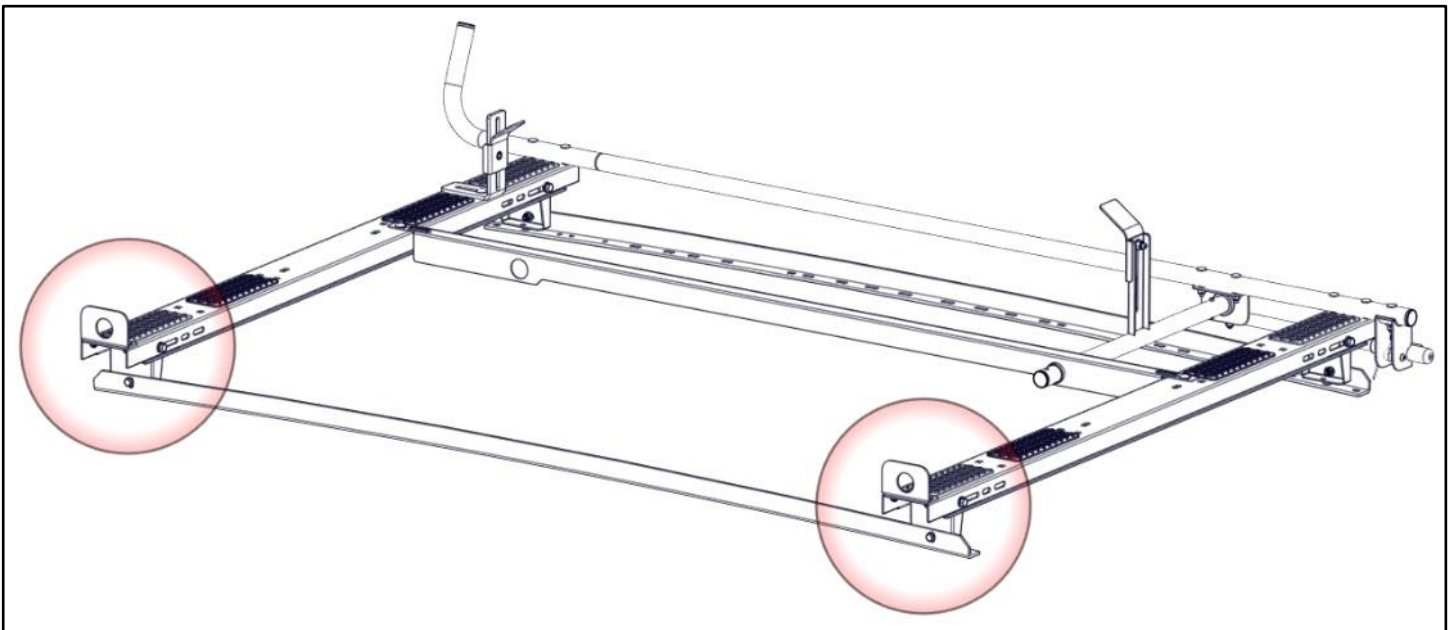
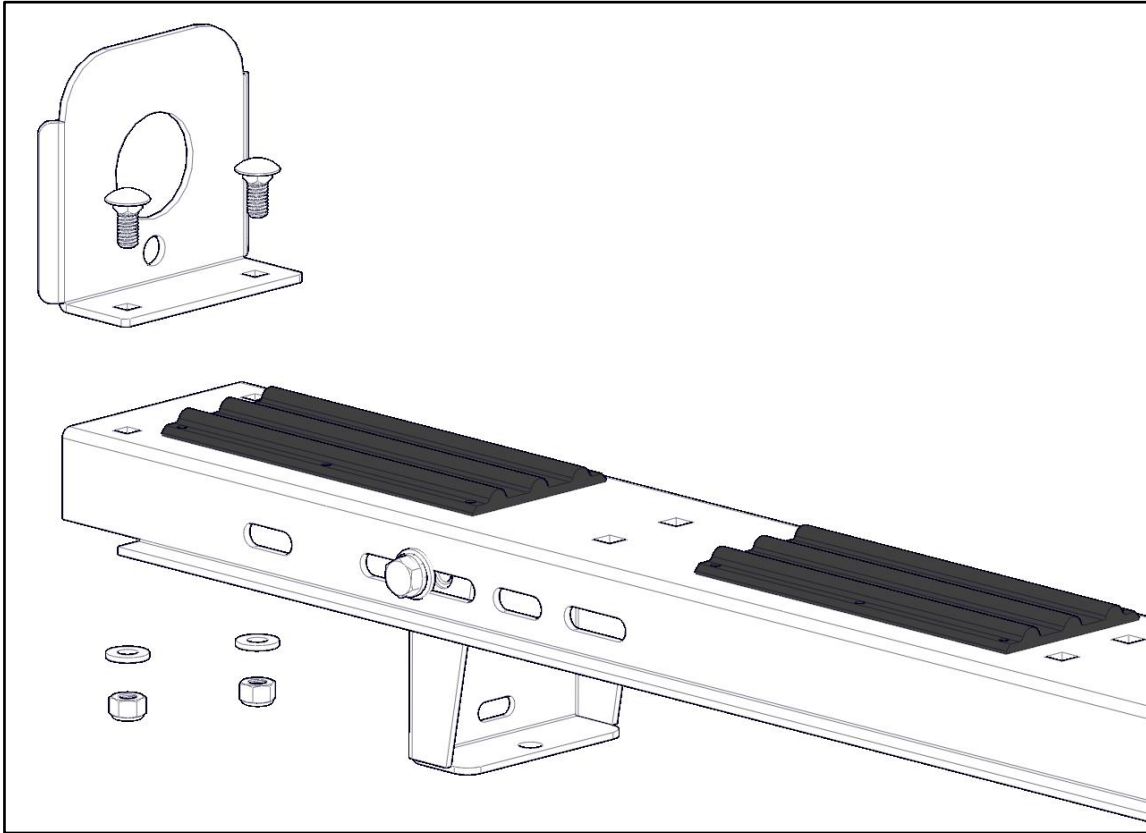

## Step 2 – Mount Side Tube

- Place a generous amount of sealant into the tube connection.
- Place side tube on top of installed bows.
- Have the bend towards the front of the vehicle as shown.
- Mount rotation bar plate to the rear of the tube as shown.
- Leave one square slot open at the rear.
- Bolt together using 5/16" x 2" carriage bolt, a 5/16" flat washer and a 5/16" nyloc.
- Snug Tighten, but allow movement.

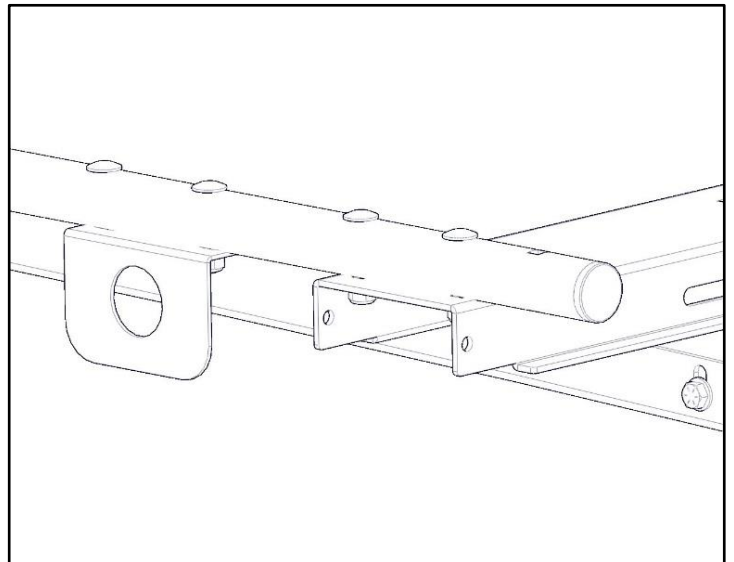
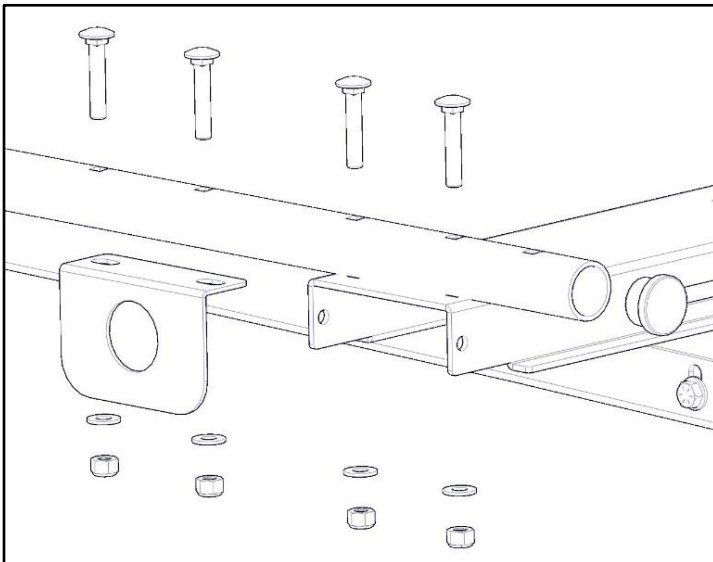
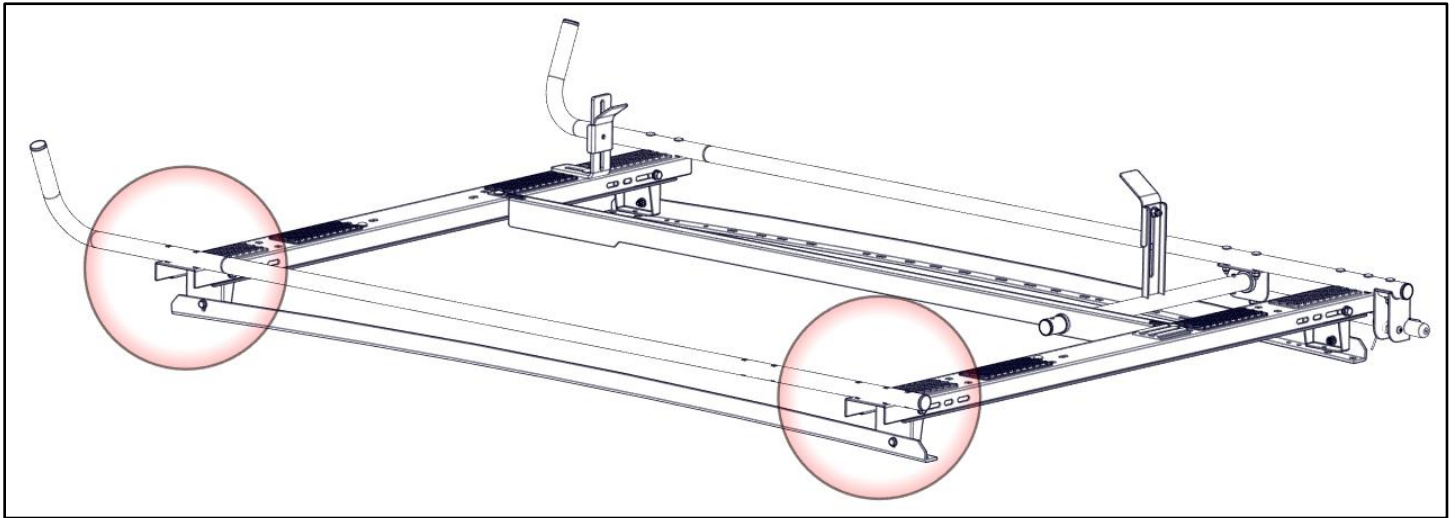
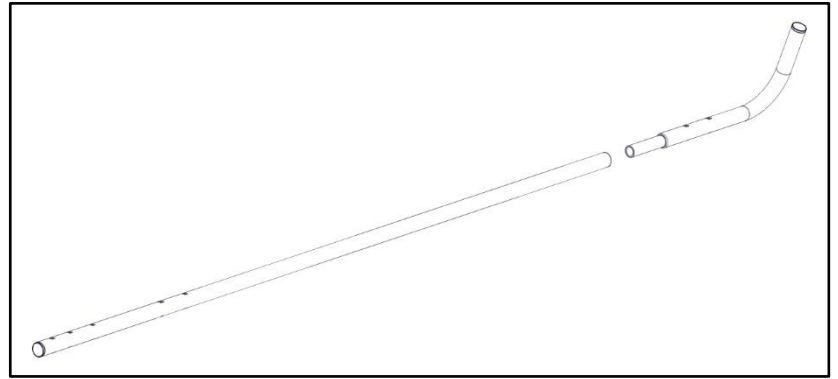

### Step 3 – Mount Clamp Tube

- Place clamp and lock L bracket on top of installed bows. Do not install hardware right now.
- Insert plastic bushings into the clamp and lock L bracket and the rotation bar plate installed in Step 2, with flanges as shown so they cannot come out at a later time. If bushings are not placed in correct orientation, they can fall out.

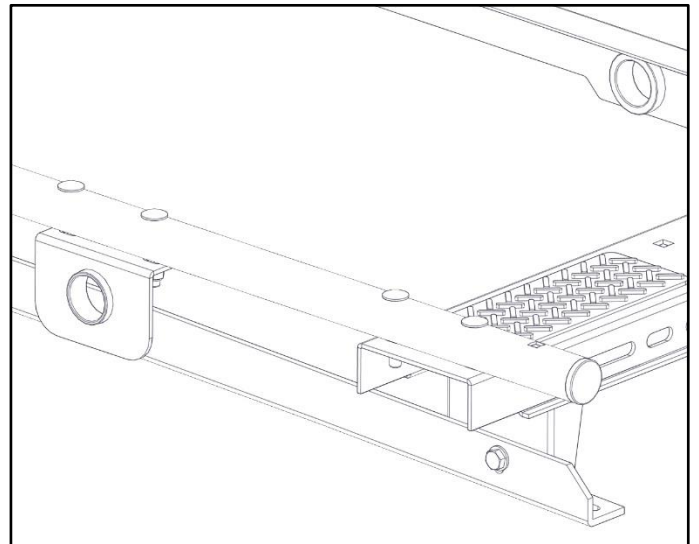
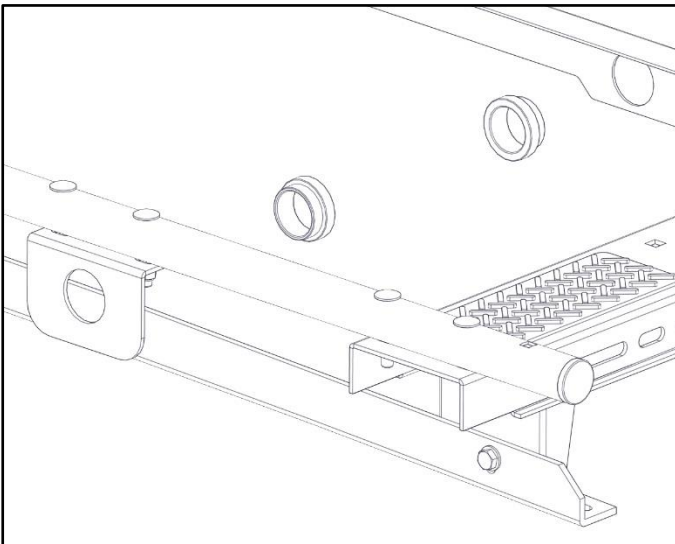
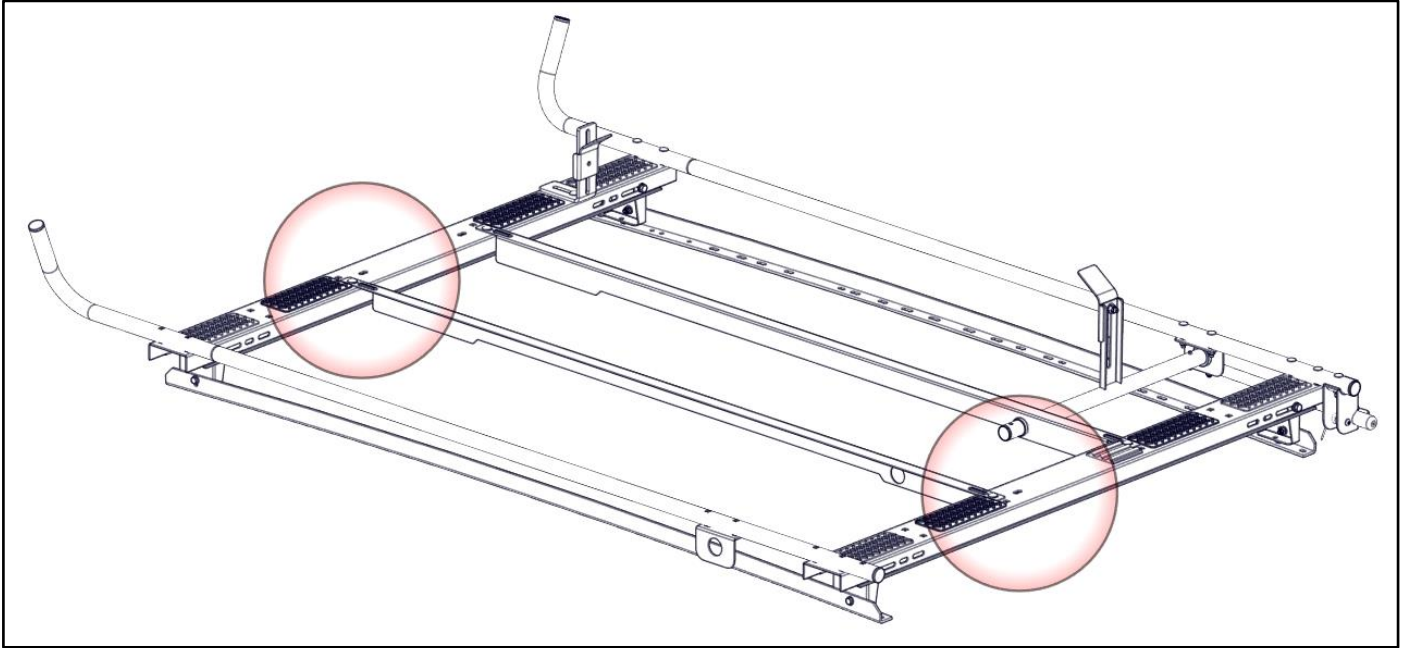

- Insert clamp tube into both plastic bushings.
- Adjust clamp on clamp tube to fit firmly against your ladder.

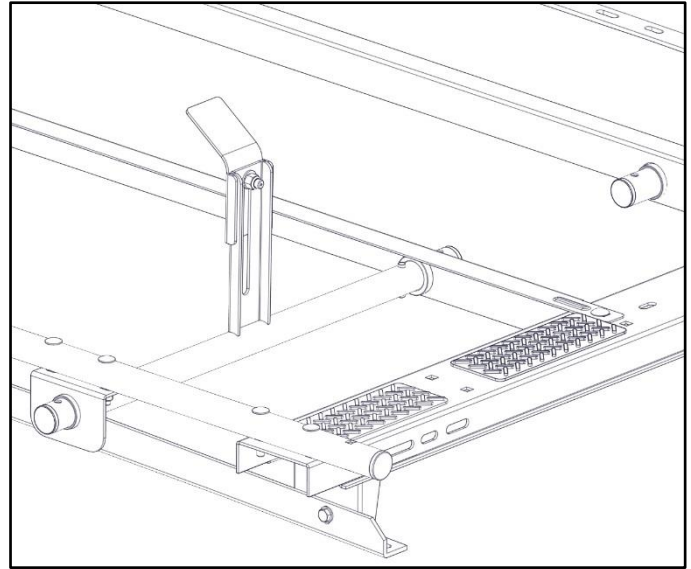
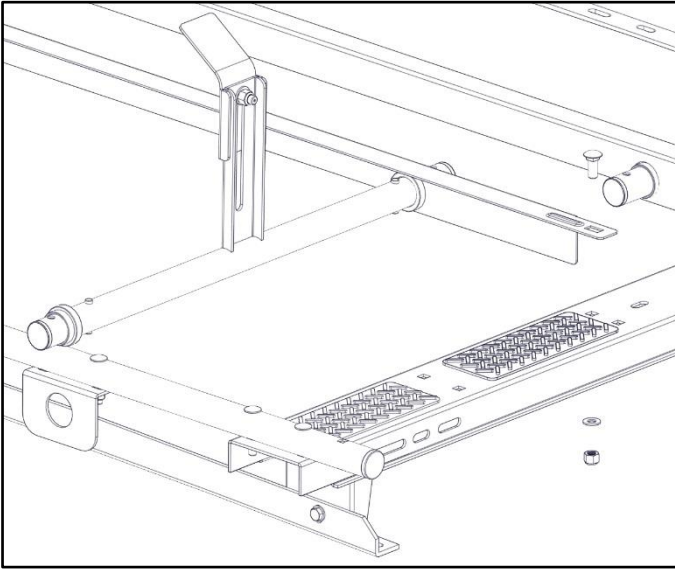

- Bolt clamp and lock L bracket to bows using 3/8" x 1" carriage bolt, 3/8" flat washer and a 3/8" nyloc as shown.
- TIGHTEN

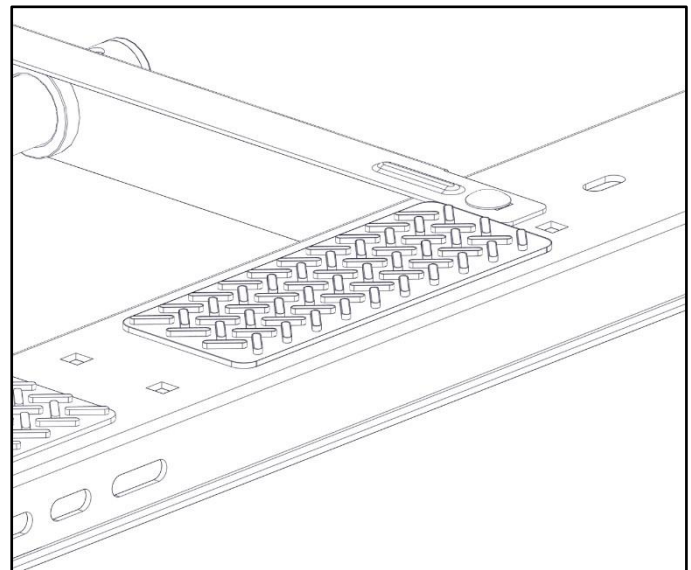
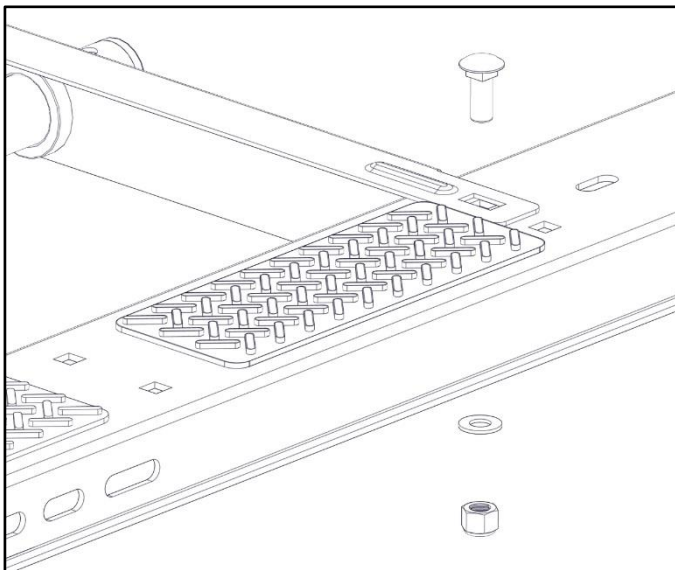



### Step 4 – Mount Handle

- Bolt handle to clamp tube using a 5/16" x 2-3/4" hex head, two 5/16" flat washers, 5/16" nylon washer and 5/16" a nyloc. The nylon washer goes in between the clamp tube and handle.
- TIGHTEN

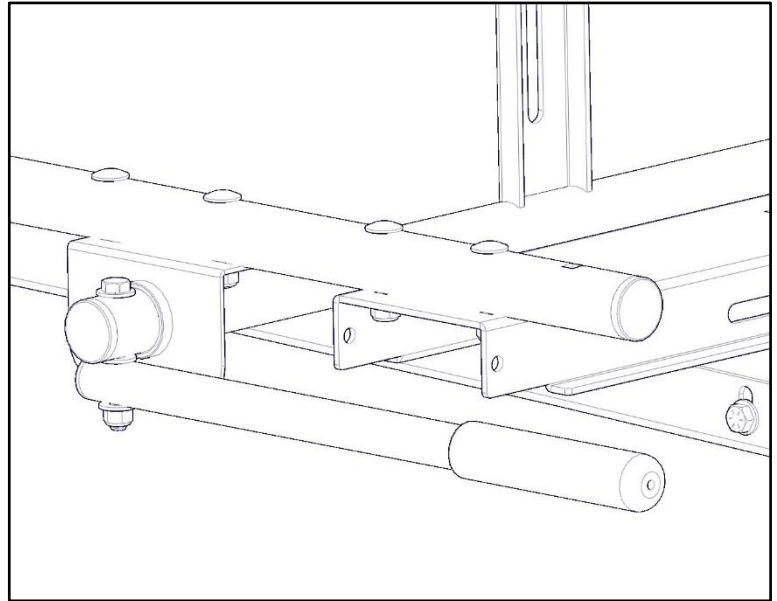
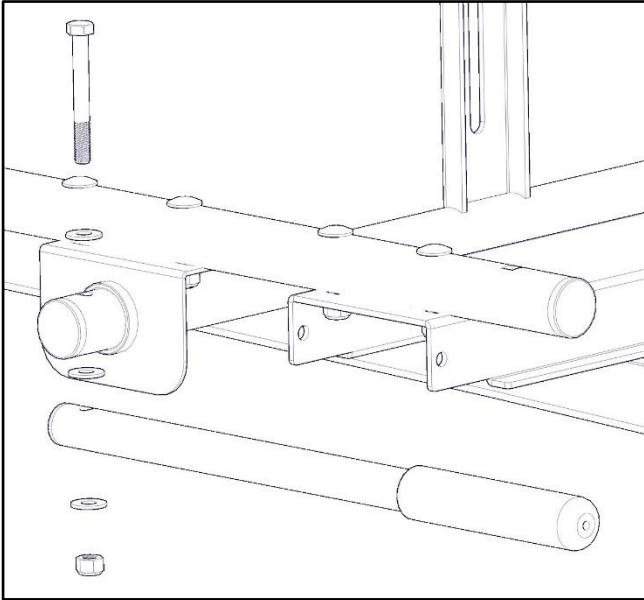

### Step 5 – Mount Latch Assembly

- Bolt latch to the rear of the mount tube that was installed in Step 5 using 5/16" x 2" carriage bolt, 5/16" curved washer and a 5/16" nyloc.
- TIGHTEN

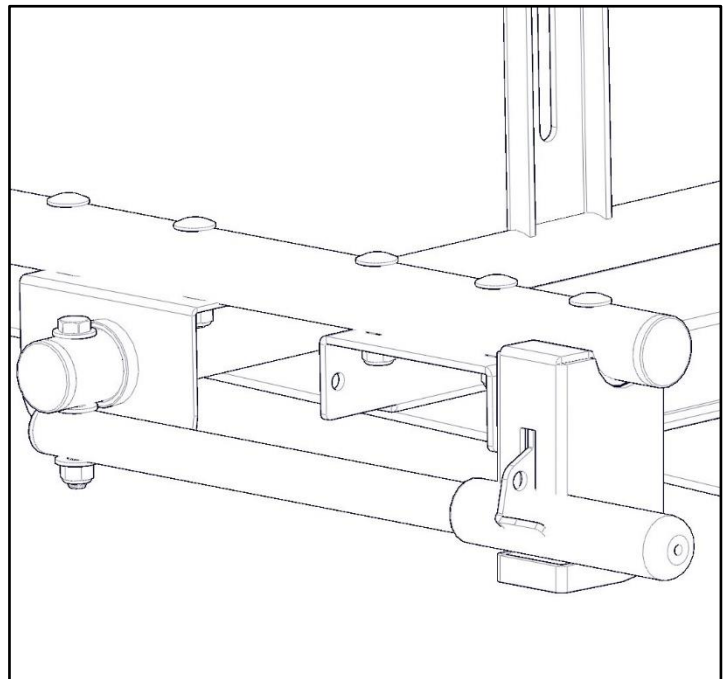
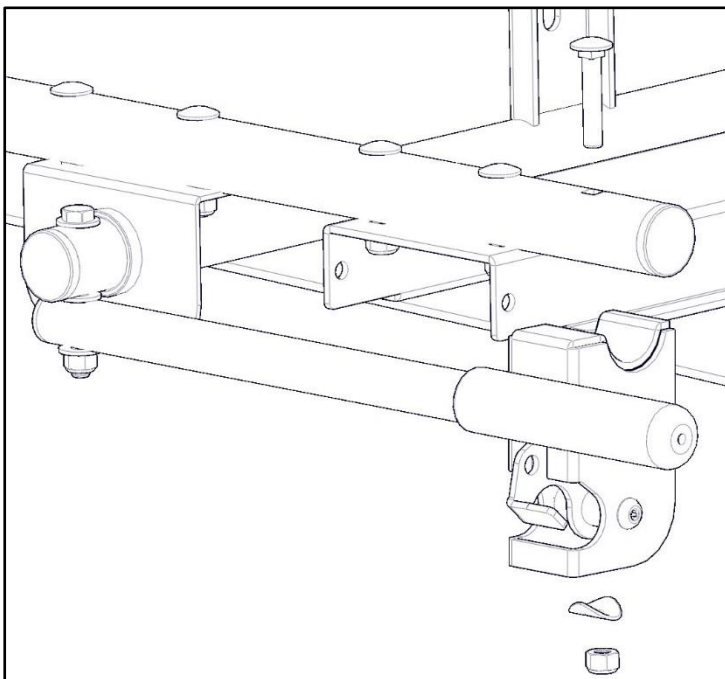

### Step 6 – Mount Ladder Hook

- Bolt ladder hook bracket to the bow in the orientation shown using a 3/8" x 1" carriage bolt, a 3/8" flat washer and a 3/8" nyloc. Be sure the bracket is square to the bow.
- Adjust clamp on bracket to fit firmly against your ladder.
- TIGHTEN

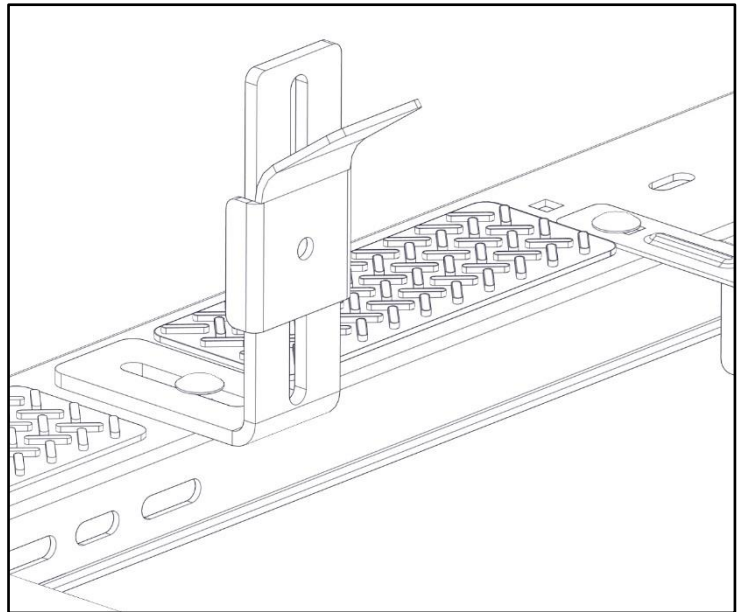
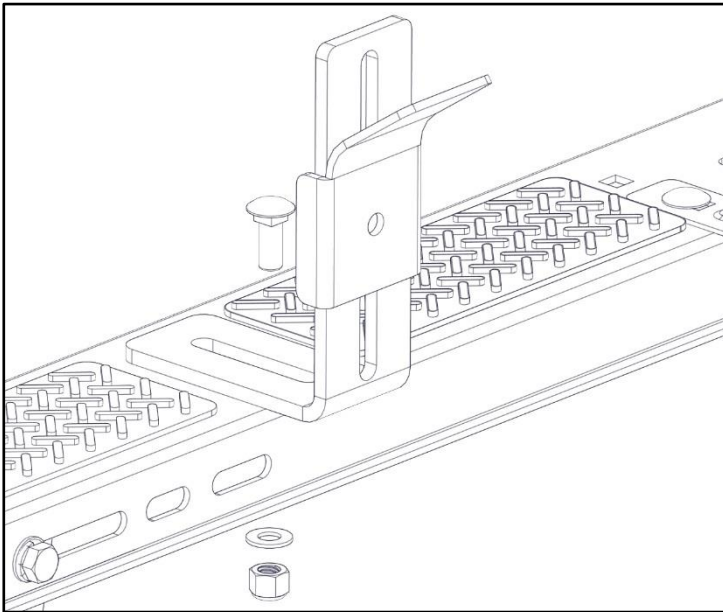

### Step 7 – Install Extra Pad

- Adjust clamp on bracket to fit firmly against your ladder.
- If ladder rests on cross bow, place extra rubber bumper to avoid scratching.

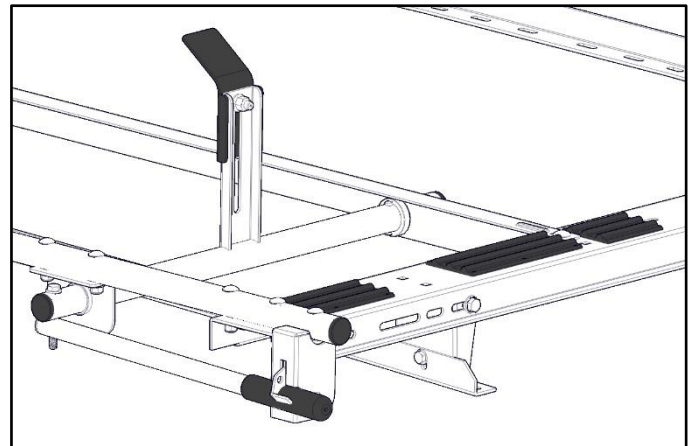
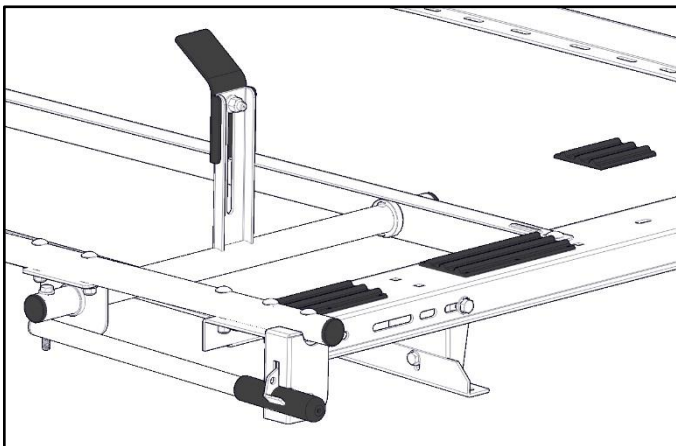

GO BACK AND ENSURE ALL HARDWARE IS TIGHT  
Your installation is now complete.

BE SURE LADDER IS SECURE PRIOR TO TRANSPORTATION

