

---

# KARGO MASTER®

**WE PUT EVERYTHING WITHIN REACH.**

---

## Instruction Guide

---

### 409TD

---



---

\*PLEASE READ ALL INSTRUCTIONS AND WARNINGS PRIOR TO ASSEMBLING,  
INSTALLING, AND USING THIS PRODUCT\*

---

## Warning



Always check for wires, fuel tanks and lines, brake lines and other important vehicle functionality items prior to drilling and installing all products.

---

## Tools Needed

13mm Wrench and Socket	1/2" Wrench and Socket
5mm Allen Hex	9/16" Wrench and Socket

---







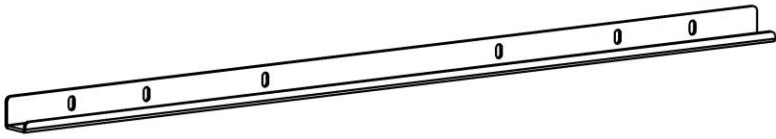
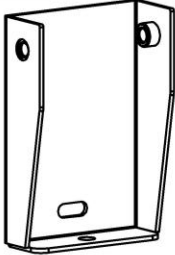
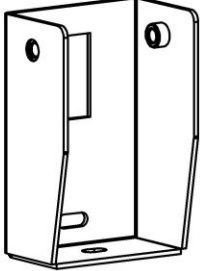
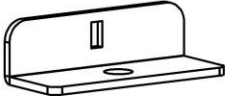
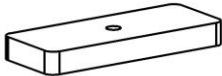

## Before You Begin

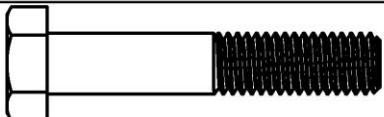
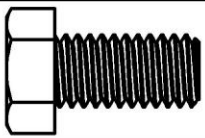
- Read ALL instructions prior to installation.
  - Mount locations will vary based on van.
  - Be sure to put sealant around exposed threads in roof. Seal between the roof and the rubber pad. Apply some sealant on the threads of all bolts going into the roof.
-

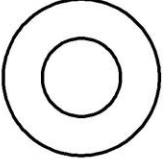
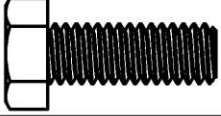
Parts

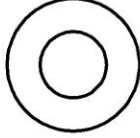
ITEM NO.		PART NUMBER	DESCRIPTION	QTY.
A		4A901-10-001	Front Rail	2
B		13-03105	Tall Foot	2
C		4090T-10-R2	Large Foot	2
D		4A9ST-00-001	Rear Mount Bracket	2
E		T249-01	Black Nylon Block	4
		18-409TD-R2	Hardware	1

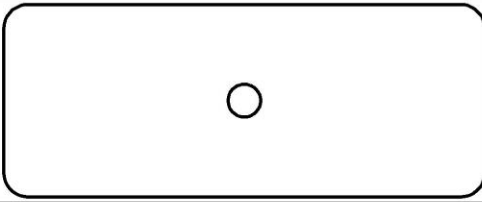
Hardware

ITEM NO.	TO SCALE	PART NUMBER	DESCRIPTION	QTY.
1		95327A569	M8x1.25 x 45mm Hex Head	4
2		92865A622	3/8" x 3/4" Hex Head	8
3		91102A760	3/8" Split Lock Washer	8
4		90126A031	3/8" Flat Washer	8
5		92865A582	5/16" x 7/8" Hex Head	4
6		95615A160	5/16" Nyloc	4
7		90126A030	5/16" Flat Washer	12
8		91102A755	5/16" Split Lock Washer	4
9		91263A845	M8x1.25 x 30mm Flat Head	2
10		T249-02	Rubber Scale 1:2	8
		BH-821	Sealant	1

## Ford Transit (EXCLUDING High Roof Extended)

### Step 1 – Rear Mounting

- Locate the threaded inserts at the rear of the van. Plugs will need to be removed.

#### 130" Wheel Base

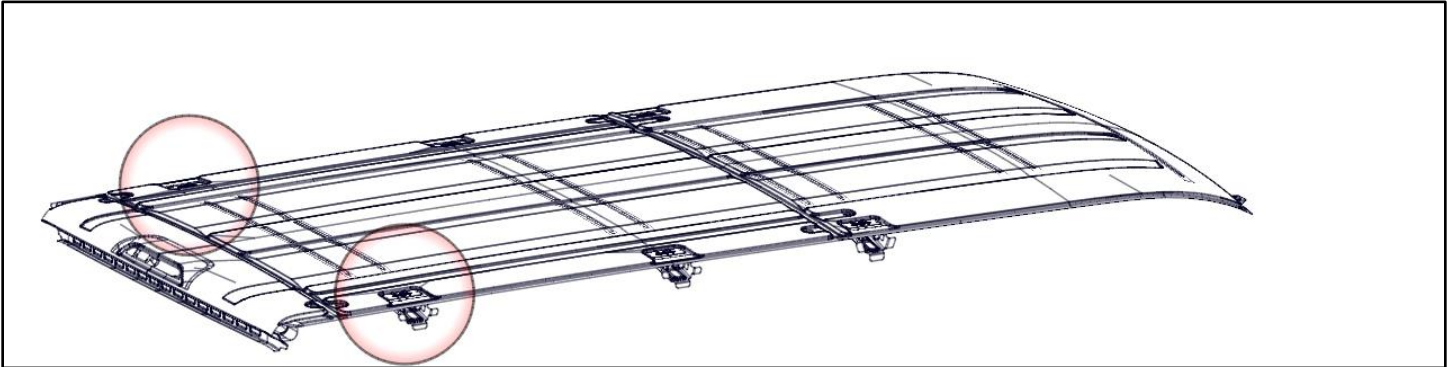

#### 148" Wheel Base

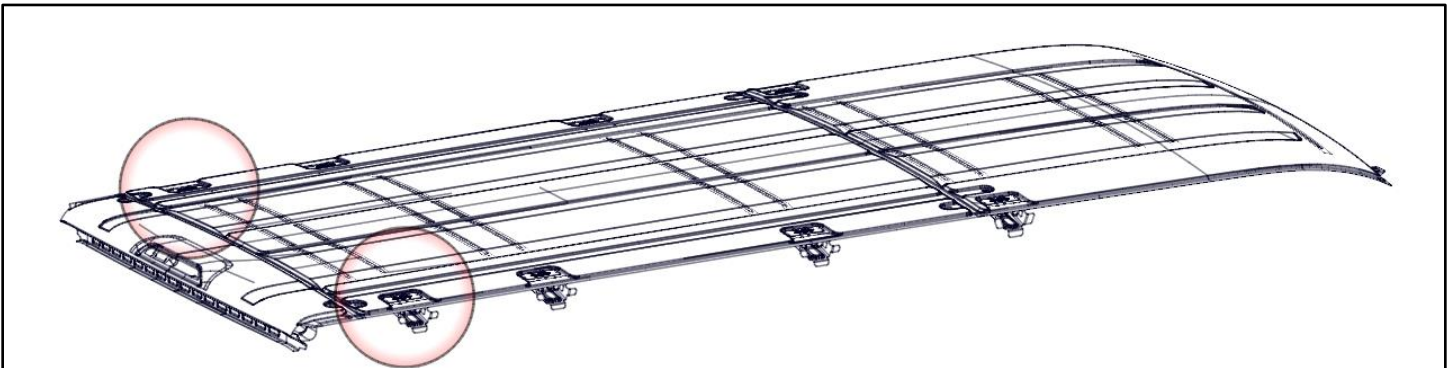

**\*\* Place sealant around the exposed holes in the roof of the van under the rubber pads to ensure no water can leak into the cabin of the van. \*\***

- Attach the rear mount bracket using M8 x 30mm flat head bolts. Place two rubber pads between the bracket and the roof of the van. The bracket should be parallel with the length of the van and the flange should be to the inside.
- Tighten. (Passenger side shown)

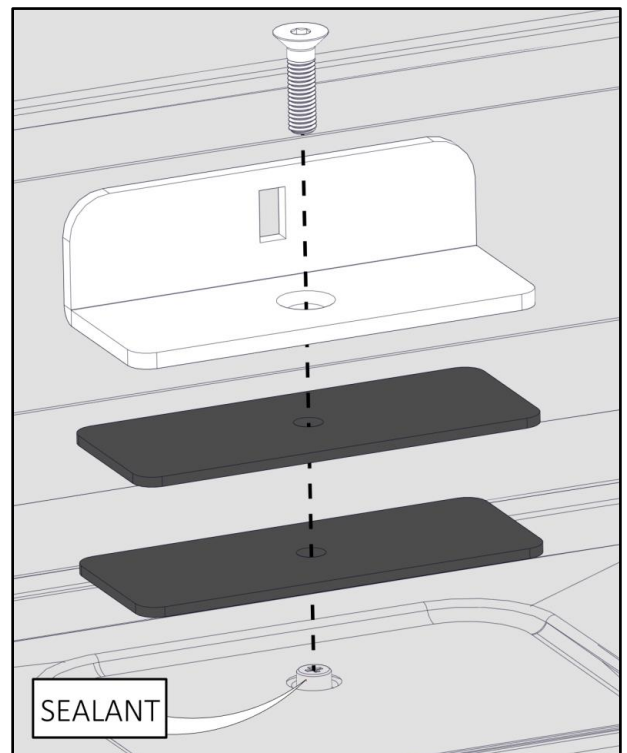

## Step 2A – Front Mount on 130” Wheel Base (Low/Mid Roof)

- Locate the other threaded inserts at the front of the van. Remove plugs.

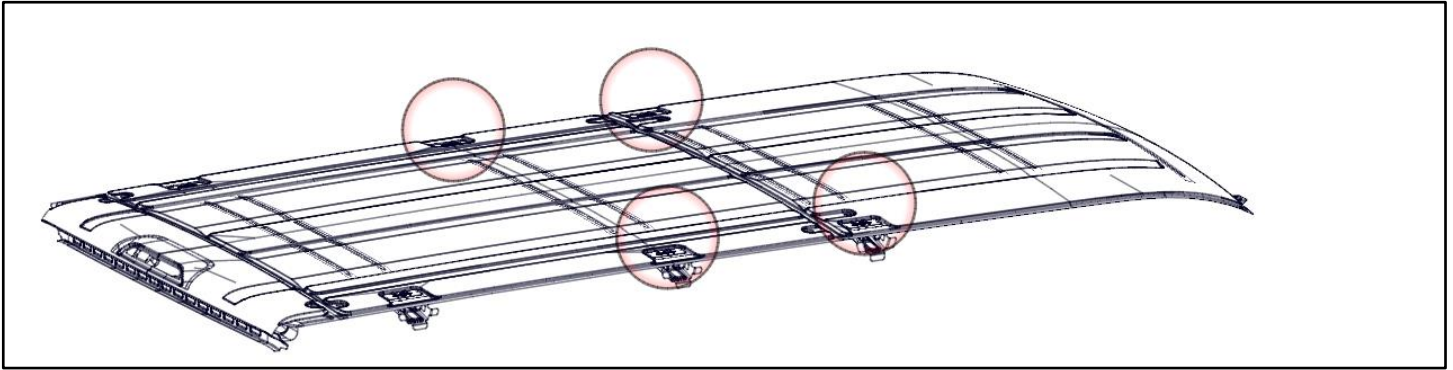

**\*\* Place sealant around the exposed holes in the roof of the van under the rubber pads to ensure no water can leak into the cabin of the van. \*\***

- Place the long mount rail with the tall flange towards the center of the van on top of the rubber pad and black nylon block.
- Bolt through farthest rear slot in the rail and the corresponding front slot using M8 x 45mm bolts with lock washers and flat washers.
- The rail should be offset to the front of the van.

(Passenger side, rear most mount on the rail shown)

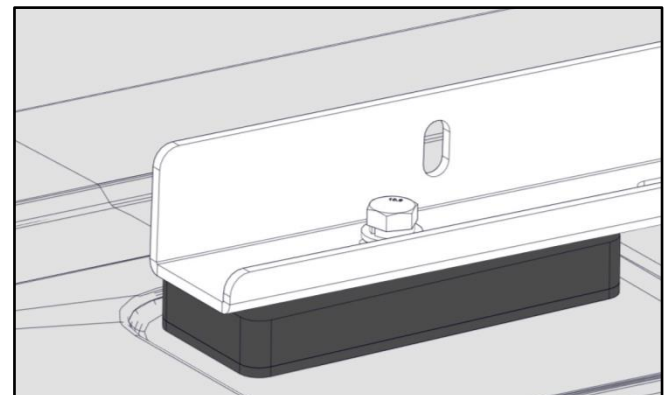
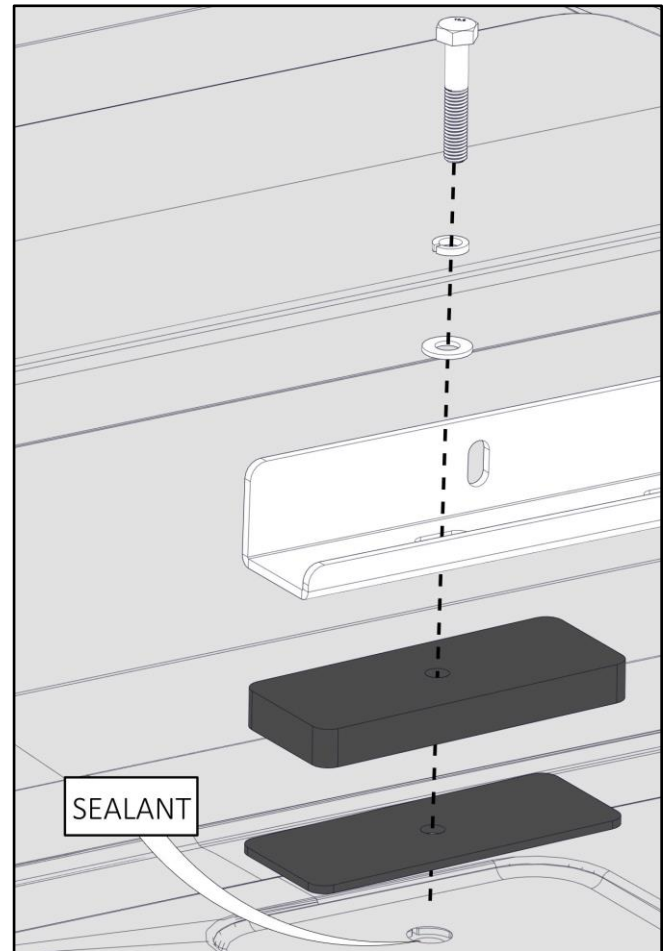

- Passenger side shown, repeat on driver side.
- Snug tighten.

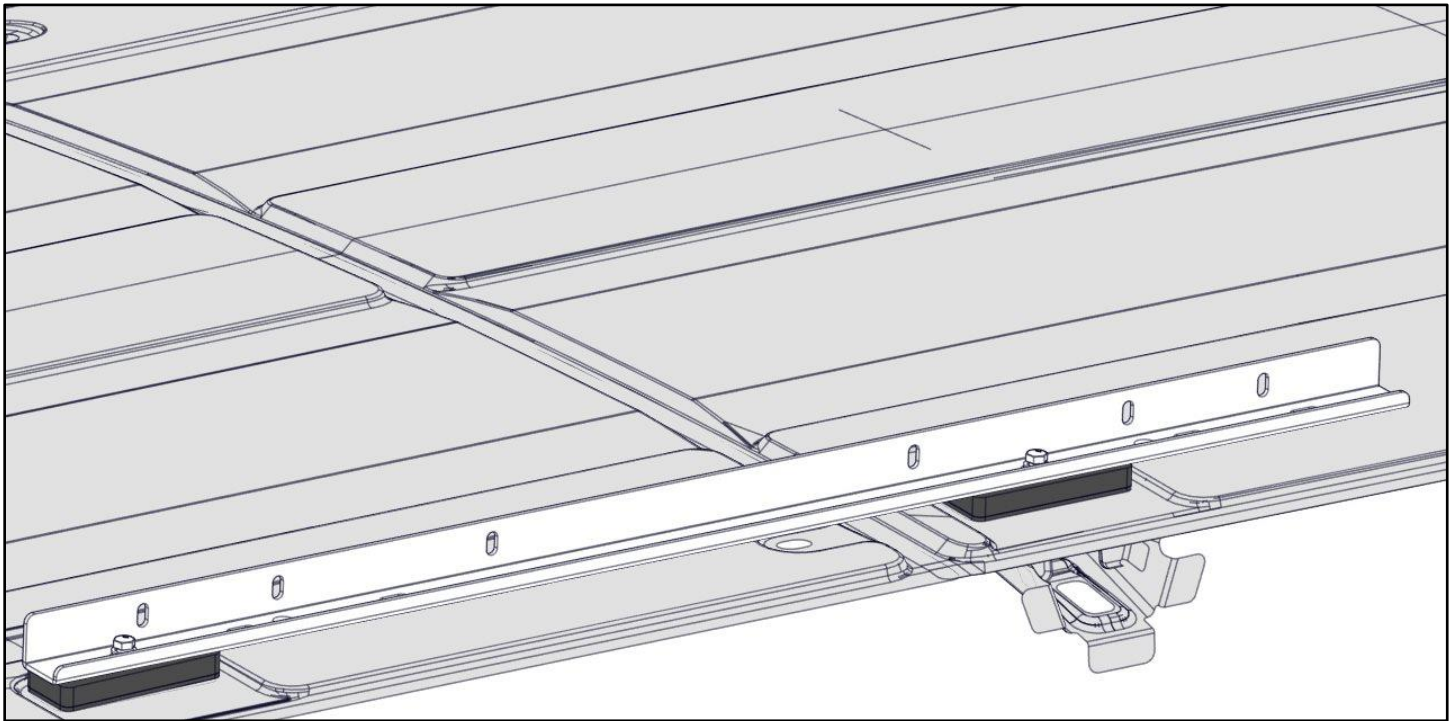
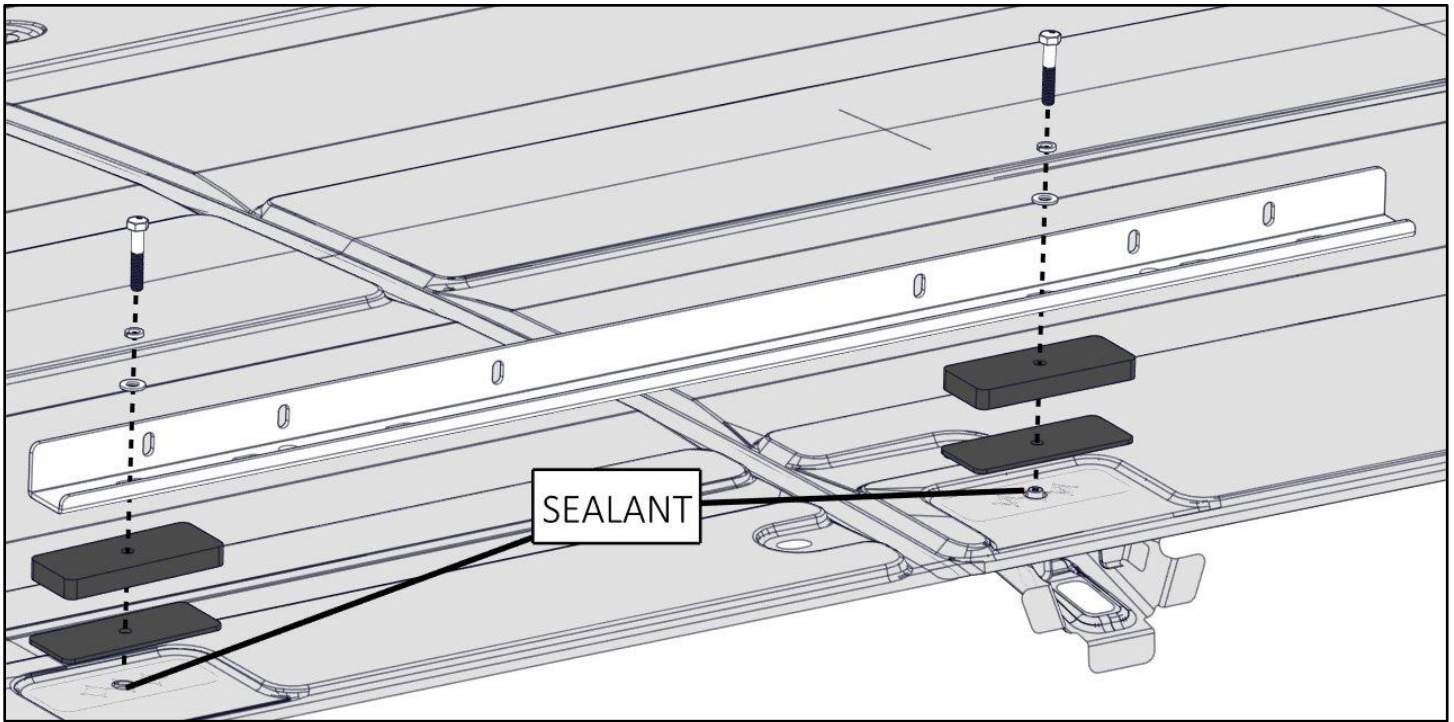

## Step 2B – Front Mount on 148” Wheel Base (Low/Mid/High Roof excluding Extended)

- Locate the other threaded inserts at the front of the van. Remove plugs.

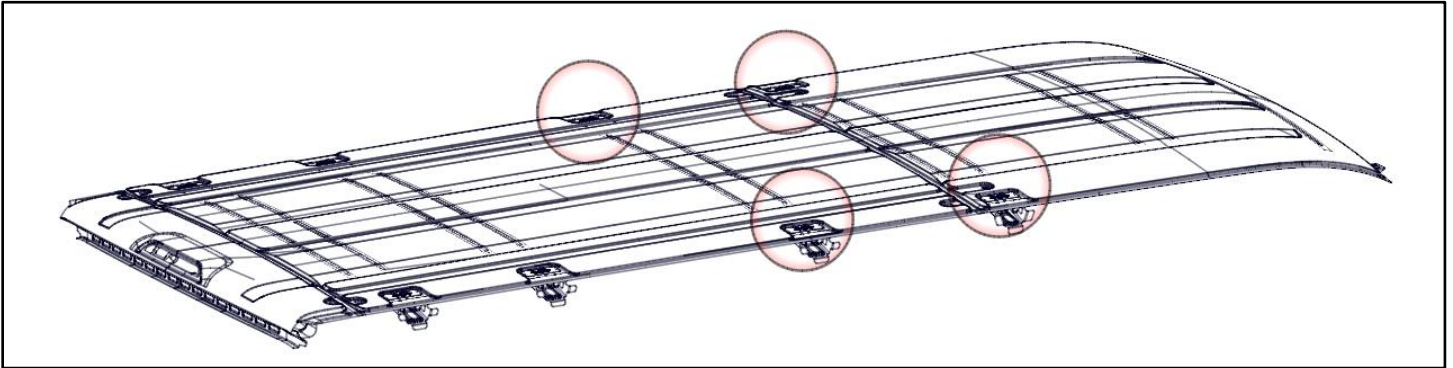

**\*\* Place sealant around the exposed holes in the roof of the van under the rubber pads to ensure no water can leak into the cabin of the van. \*\***

- Place the mount rail with the tall flange towards center of the van on top of the rubber pad and black nylon block.
- Bolt through the farthest rear slot in the mount rail and corresponding front slot in the rail using M8 x 45mm bolts with lock washers and flat washers.
- The rail should be offset to the front of the van.

(Passenger side, rear most mount on the rail shown)

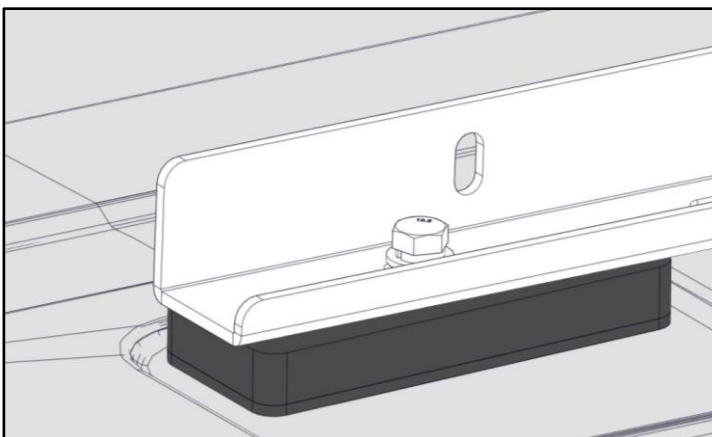
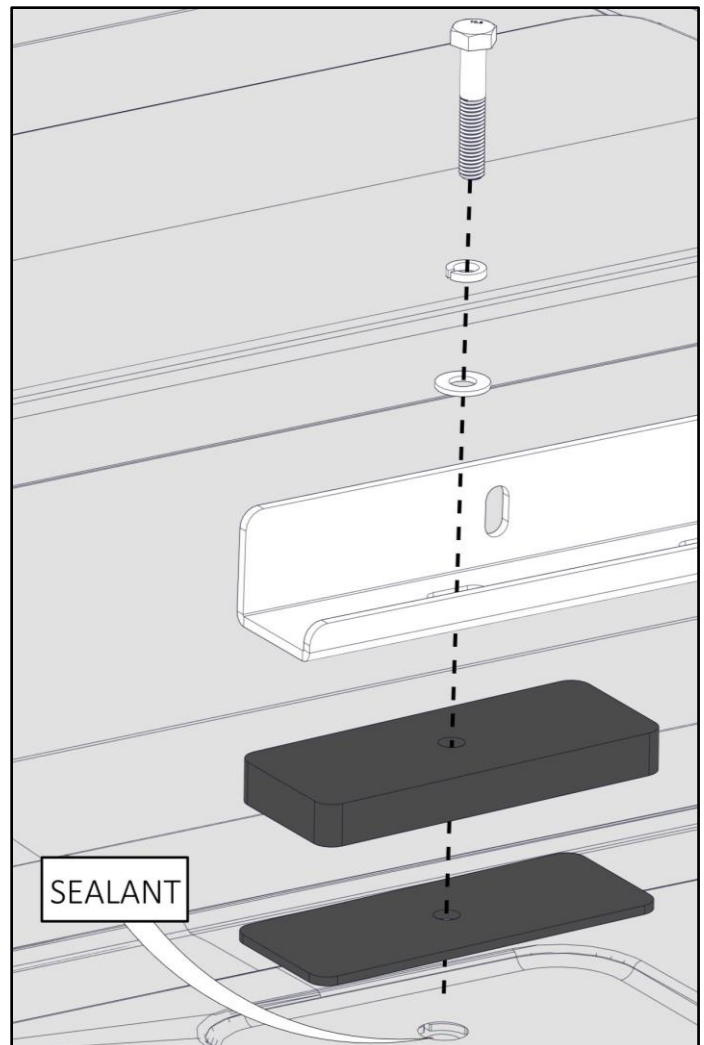



- Passenger side shown, repeat on driver side.
- Snug Tighten.

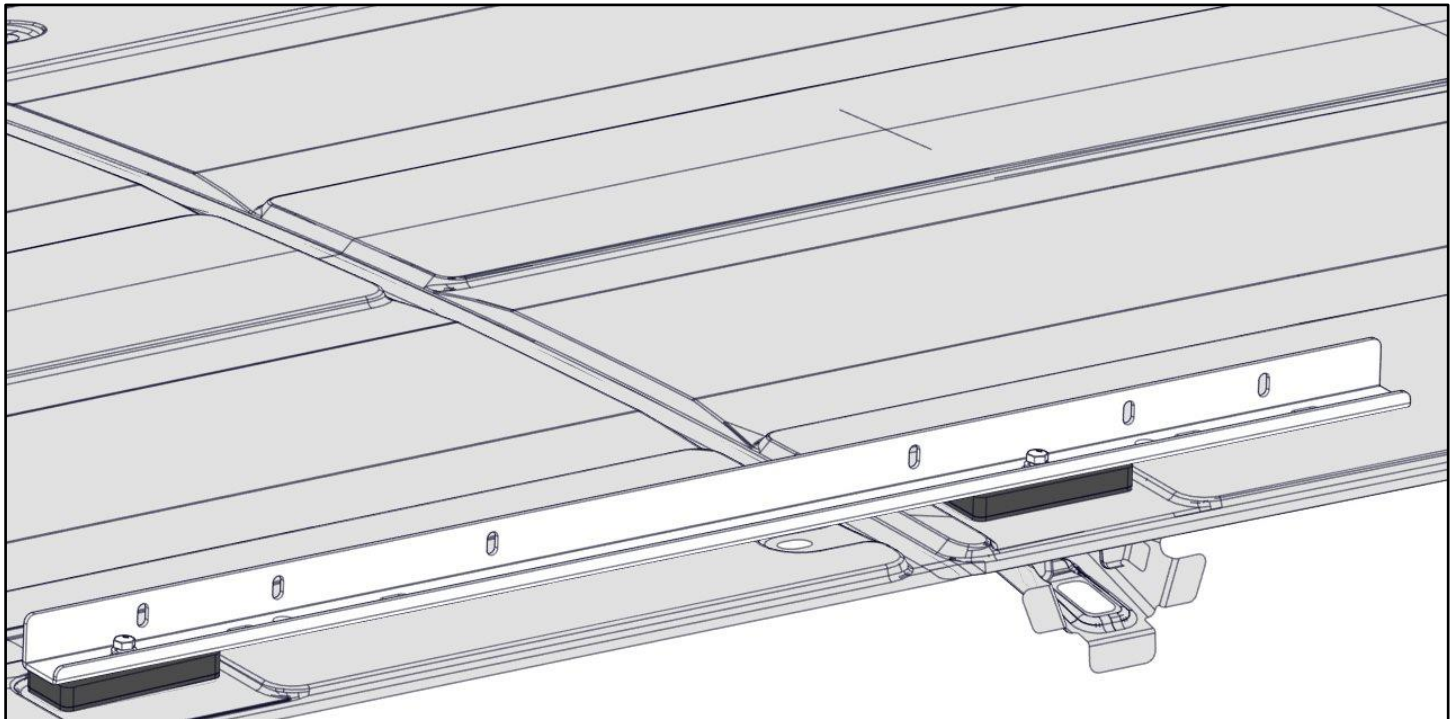
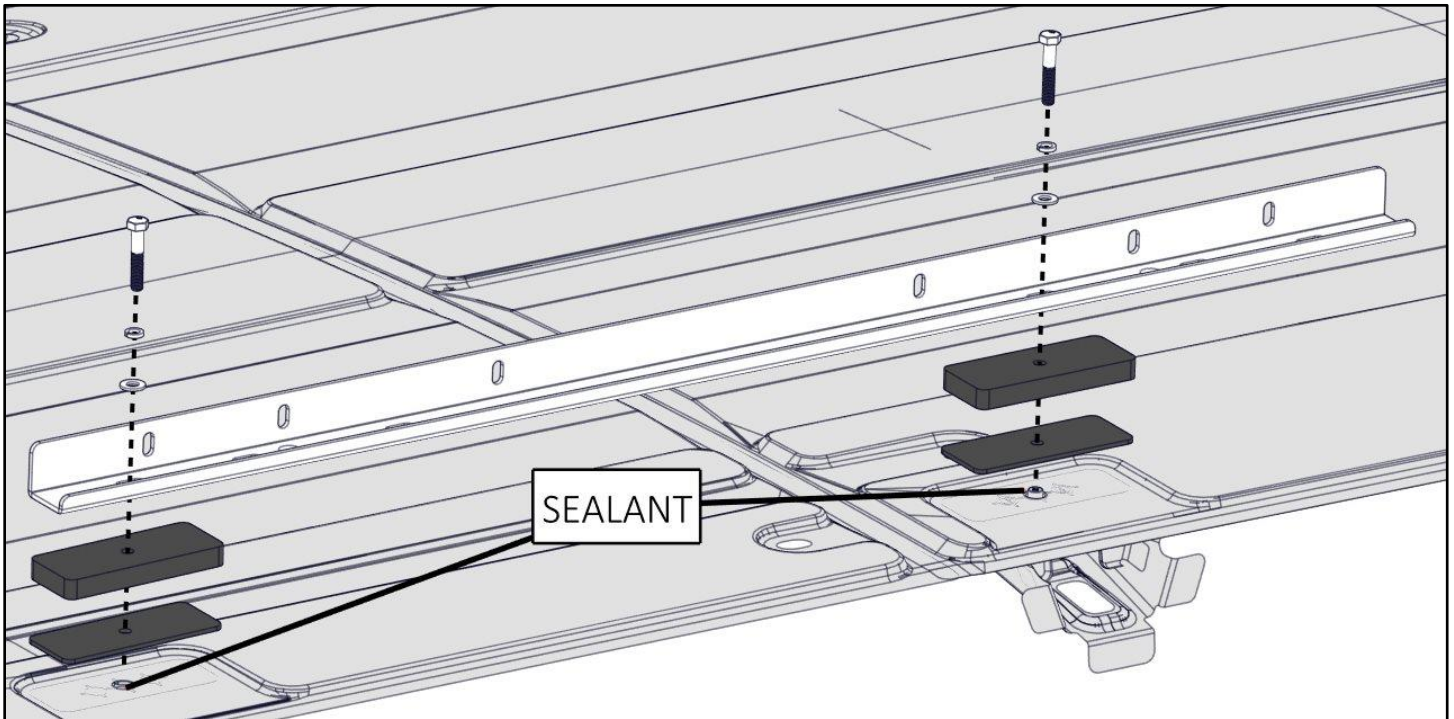

## Transit 148" Wheelbase, High Roof, Extended

### Step 3A - Extended - Rear Foot Mounting

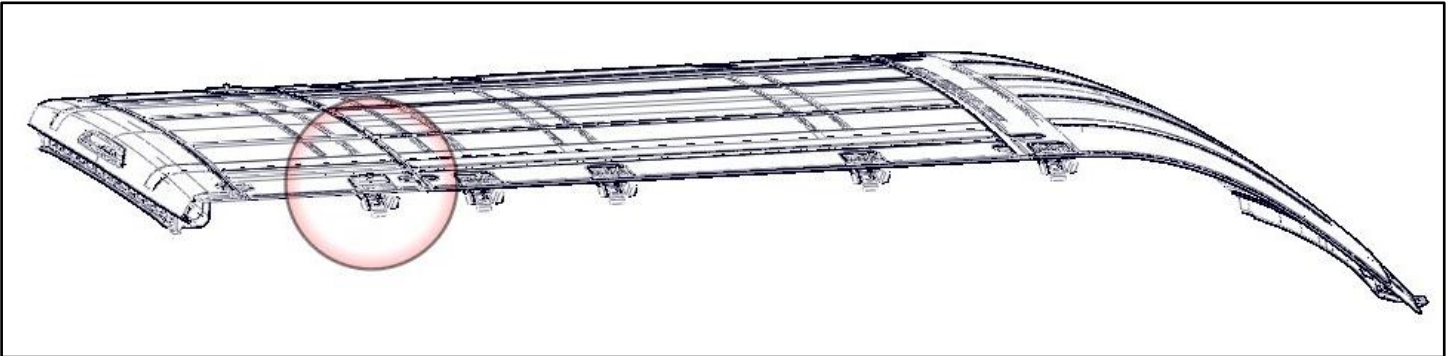

**\*\* Place sealant around the exposed holes in the roof of the van under the rubber pads to ensure no water can leak into the cabin of the van. \*\***

- Mount rear mount bracket using M8 x 30mm flat head bolts. Place two rubber pads between the bracket and the roof of the van. The bracket should be parallel with the length of the van and the flange should be towards the center as shown.

(Passenger side shown)

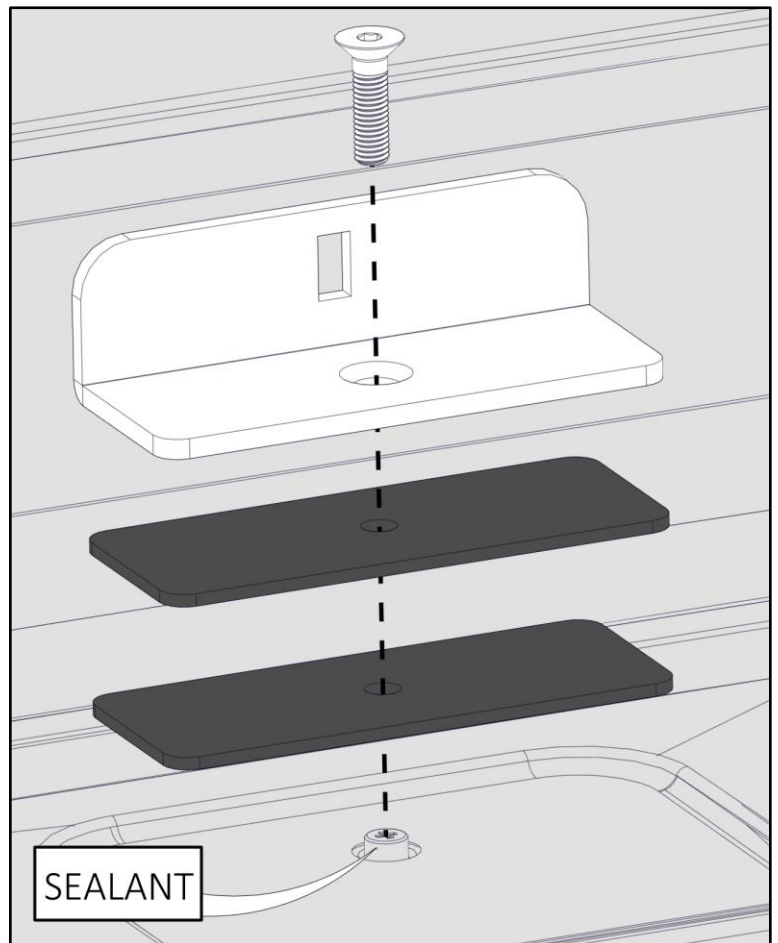

## Step 3B - Extended - Front Mount

- Locate the other two threaded inserts at the front of the van. Remove plugs.

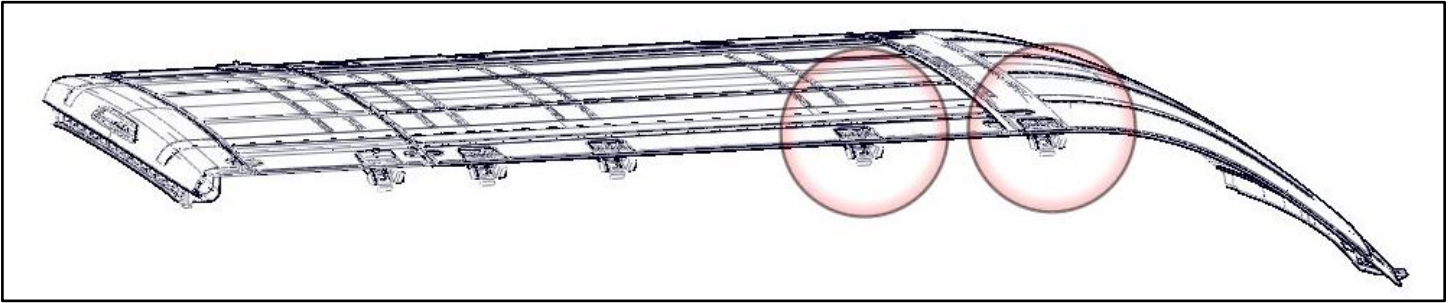

**\*\* Place sealant around the exposed holes in the roof of the van under the rubber pads to ensure no water can leak into the cabin of the van. \*\***

- Place the long mount rail with the tall flange towards the center of the van.
- Bolt through the farthest rear countersunk hole and the 2nd slot from the front using M8 x 45mm bolts with lock washers and flat washers.

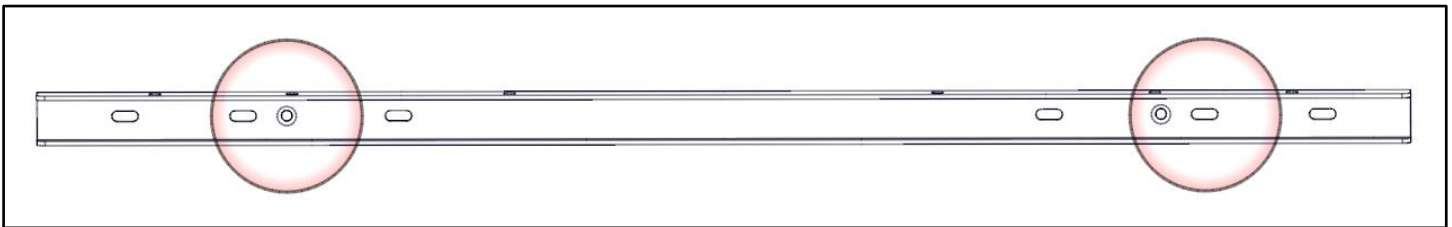

- The picture shown below is the rear most mount on the rail. (through the countersunk hole)
- Passenger side shown, repeat on driver side.
- Snug Tighten.

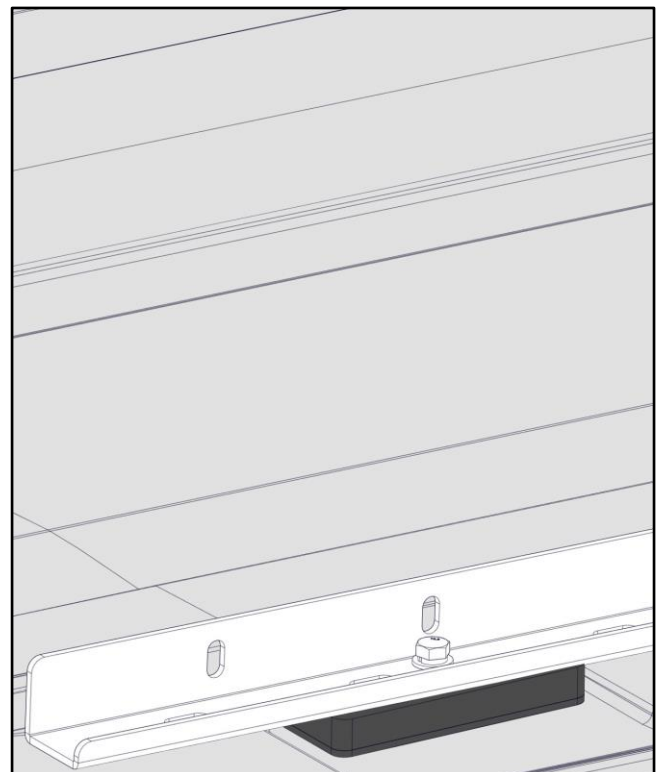
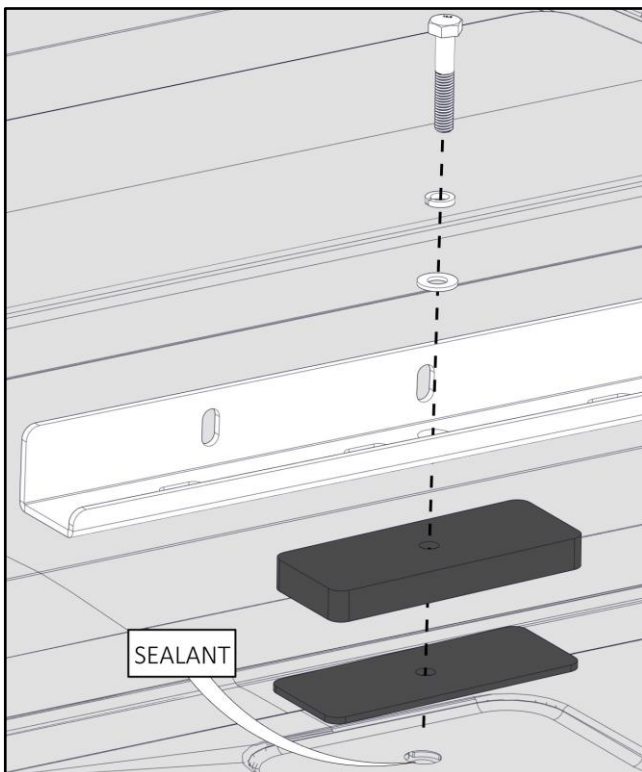

## Step 4 – Install Rear Feet

- Bolt large foot (has a cut out) to the rear mount previously installed using 5/16" x 7/8" hex head bolt, two 5/16" flat washers and a 5/16" nyloc nut. (Passenger side shown without roof and rack for clarity)

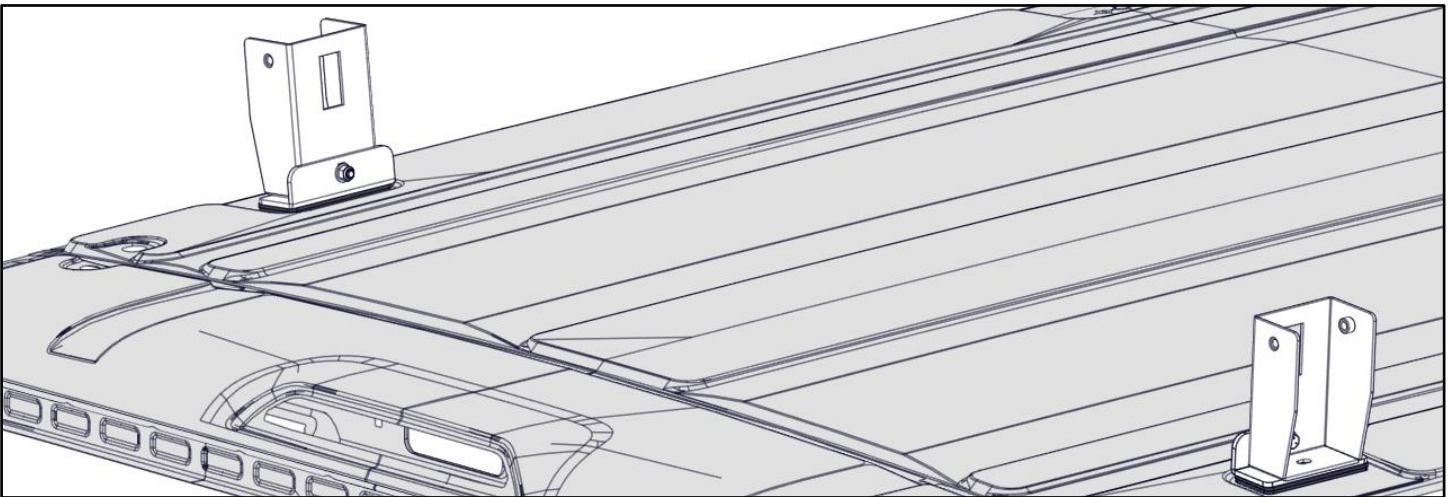
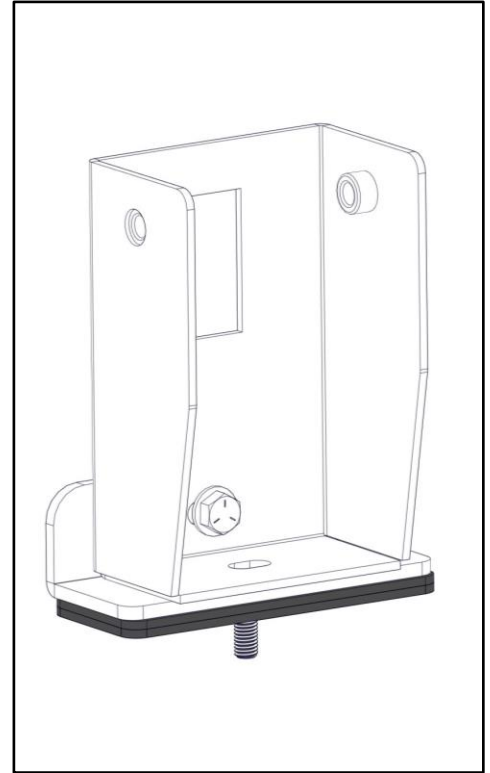
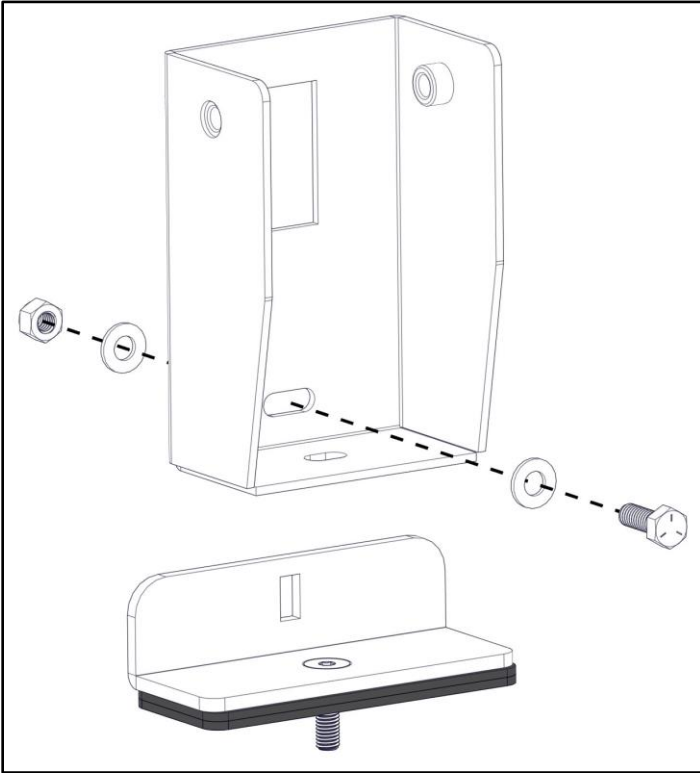

## Step 5 – Install Front Feet

- Mount the tall foot to the previously installed rail using a 5/16" x 7/8" hex head bolt, two 5/16" flat washers and a 5/16" nyloc nut.
- Be sure the distance between the two feet closely matches the distance between the bows on the ladder rack being installed. The slot used on the front rail will vary from the picture below.

Note: One may choose to install the feet on the rack prior to installing onto the vehicle. It is the installers preference.

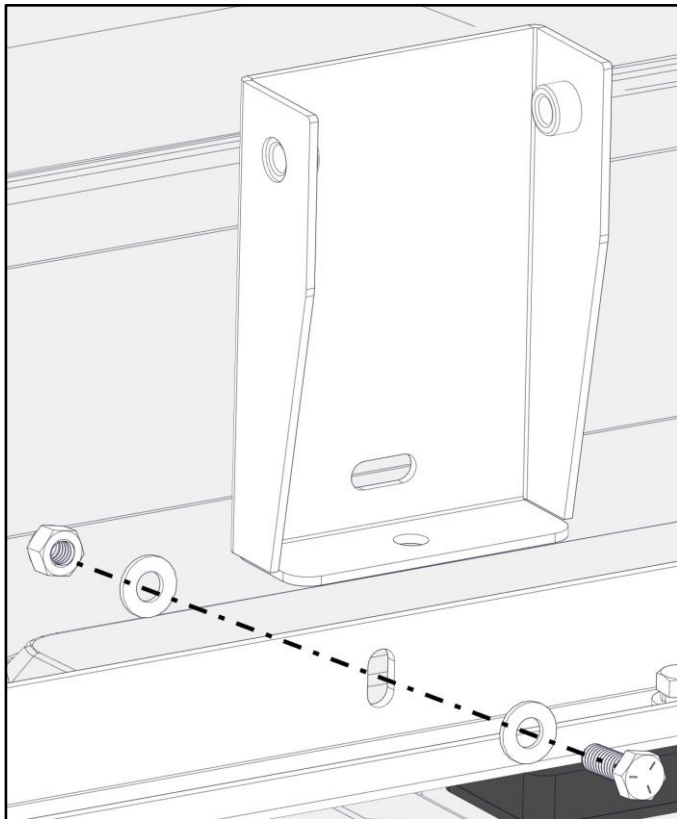
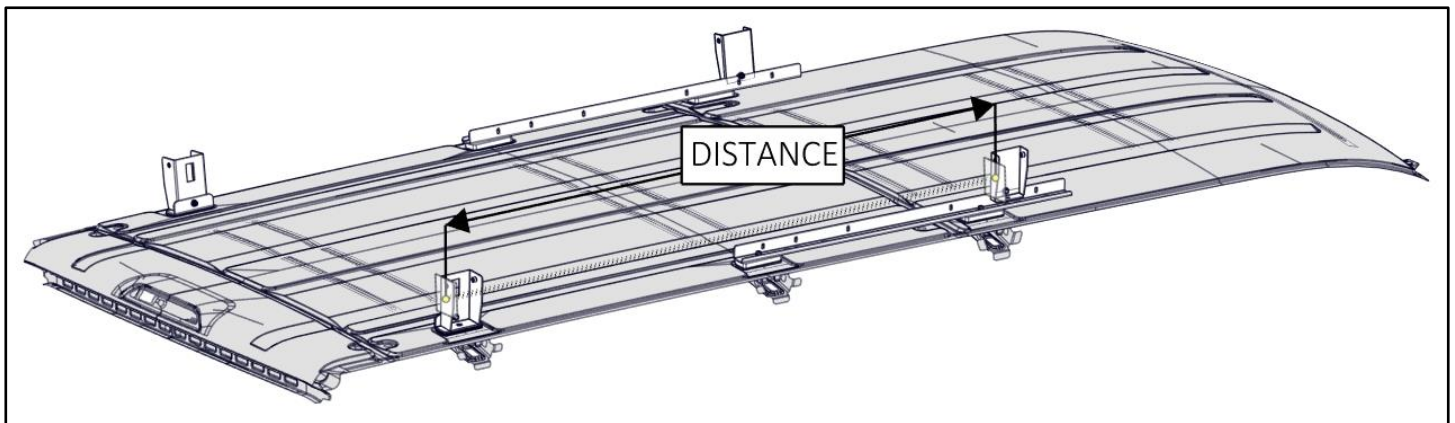

## Step 6 – Feet to Rack

- Place assembled ladder rack on top of the previously installed feet.
- Measure width between the mounts on the van.
- Center the assembled rack on top of the installed feet. Align bow with the same slot on opposite ends.
- Bolt the feet to the bows as shown using 3/8" x 3/4" hex head bolts, 3/8" lock washers and a 3/8" flat washers.

Note: One may choose to install the feet on the rack prior to installing onto the vehicle. It is the installers preference.

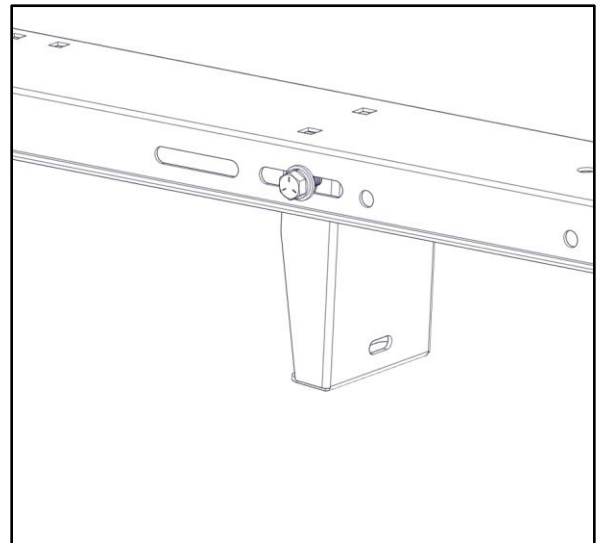
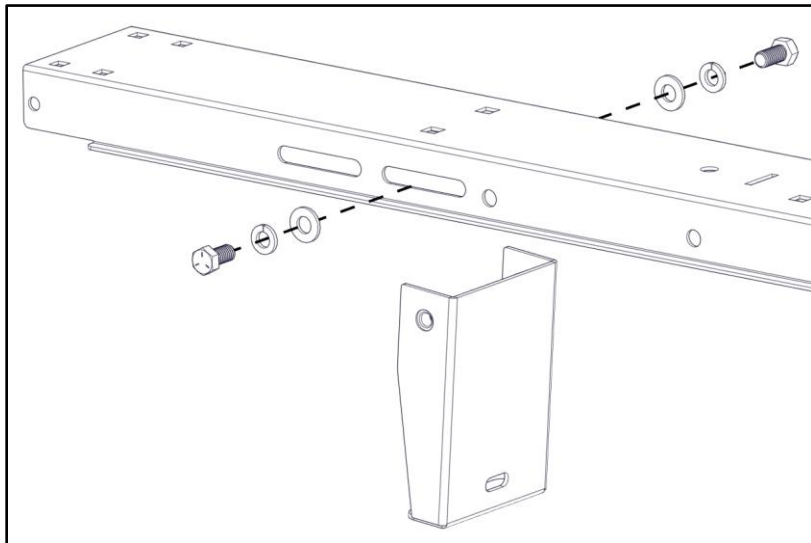
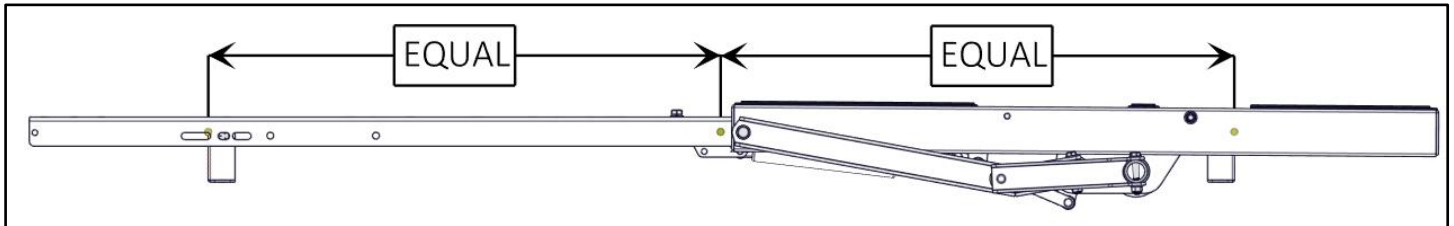
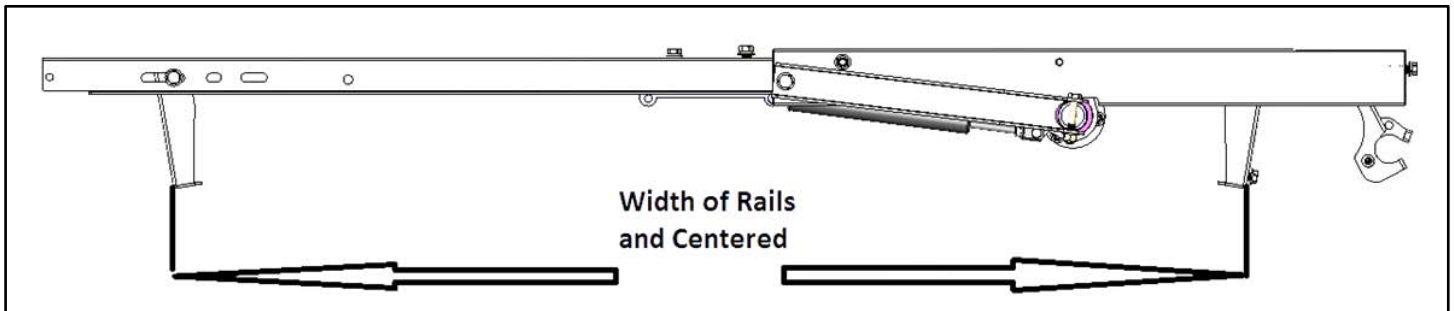

Go back and square the rack.

Ensure all hardware is tight. This includes into the roof, within the rack assembly and the mounting of the rack to roof mounts.

Your installation is complete.

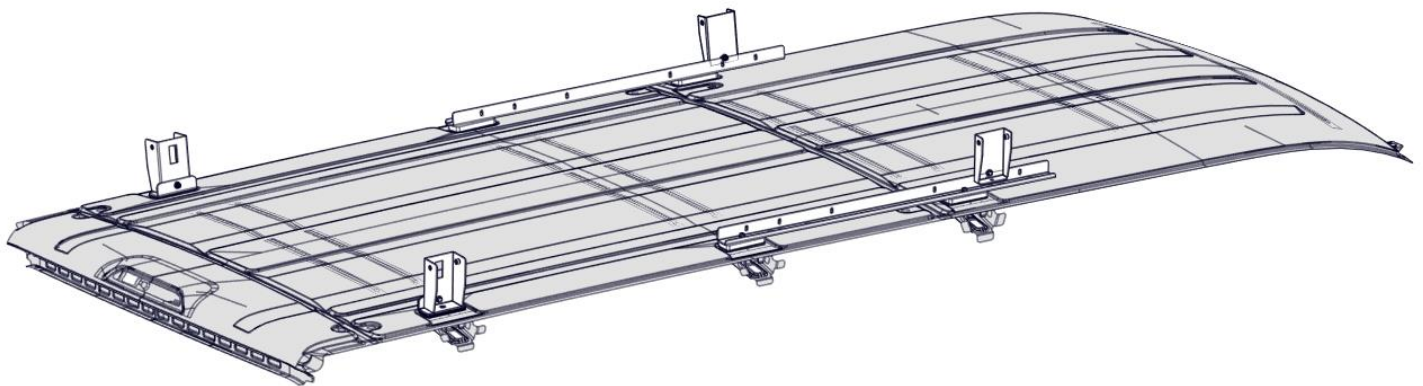

---

# KARGO MASTER®

**WE PUT EVERYTHING WITHIN REACH.**

---

## Installation Guide

---

4092L

---

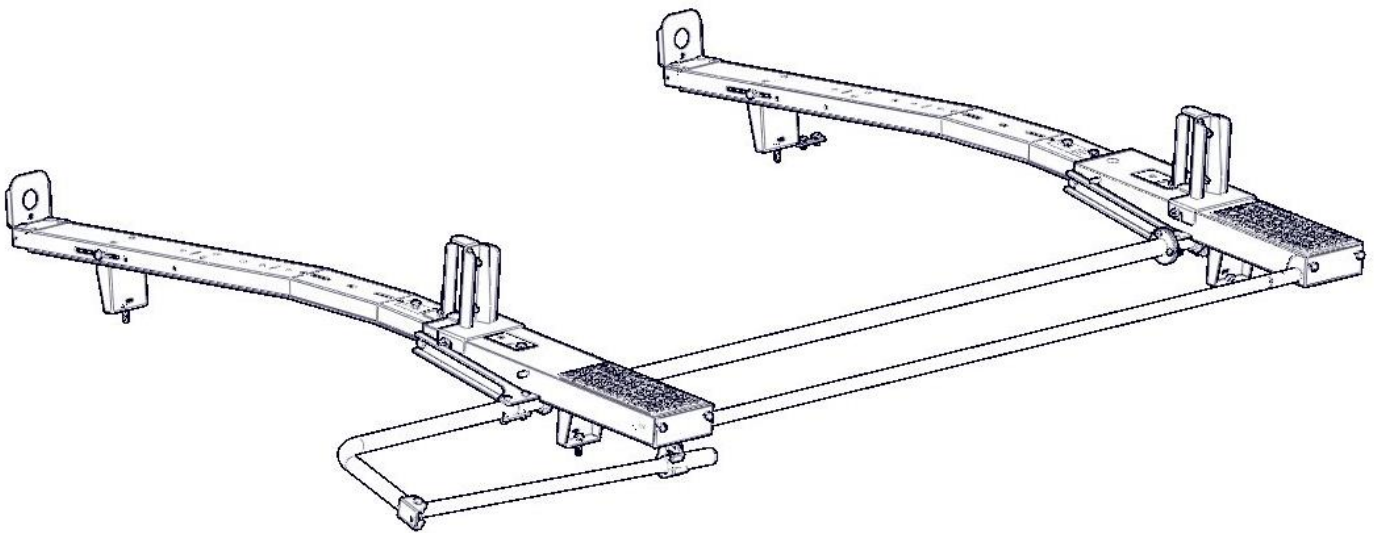



---

**\*PLEASE READ ALL INSTRUCTIONS AND WARNINGS PRIOR TO ASSEMBLING,  
INSTALLING, AND USING THIS PRODUCT\***

---

**Warning**



Always check for wires, fuel tanks and lines, brake lines and other important vehicle functionality items prior to drilling and installing all products.

---

**Tools Needed**







1/2" Wrench and Socket	7/16" Wrench and Socket
9/16" Wrench and Socket	Tape Measure

---

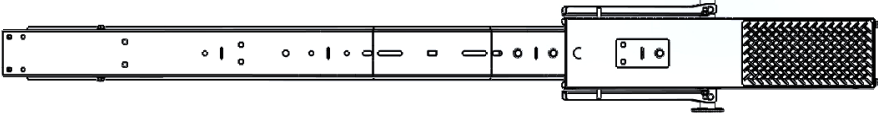
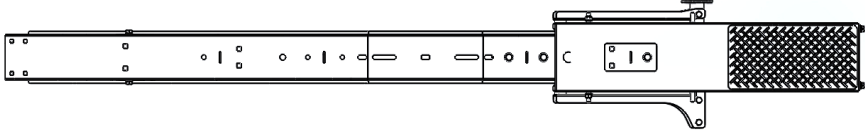

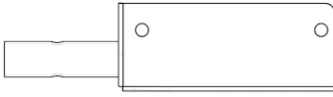

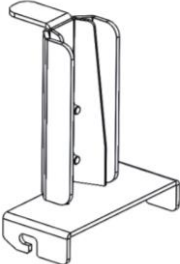
**Before You Begin**

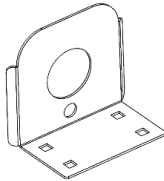
- Read all instructions.
-

Parts

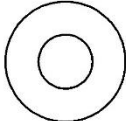
ITEM NO.	4092L PARTS	DESCRIPTION	QTY
A		Front Bow Assembly	1
B		Rear Bow Assembly	1
C		Torque Tube	1
D		Support Tube	1
E		Support Tube End	1
F		Handle	1
G		Ladder Hook	2
H		Ladder Stop	2
J		Load Plate	2
		HARDWARE	1

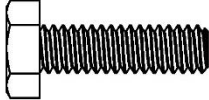
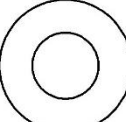
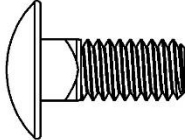
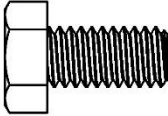
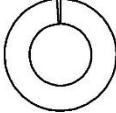
Hardware

ITEM NO.	TO SCALE	DESCRIPTION	QTY.
1		.25 flat washer	12
2		.25-20 NYLOC NUT	6
3		.25-20 x .875 HH	6
4		.312 Flat Washer	10
5		.312-18 x .75 Carriage Bolt	6
6		.312-18 x .625 HH	4
7		.312 Split Lock Washer	4
8		.312-18 Nyloc Nut	6
9		E6000	1

## Step 1 – Install Load Plate

- Next bolt the Load Plate (J) on the driver side of both bows (A&B) using .312" x .75" carriage bolts (5) with .312" nyloc nuts (8) and .312" flat washers (4) as shown.
  - The "Load Plate will NOT be used if installing a double drop down rack.

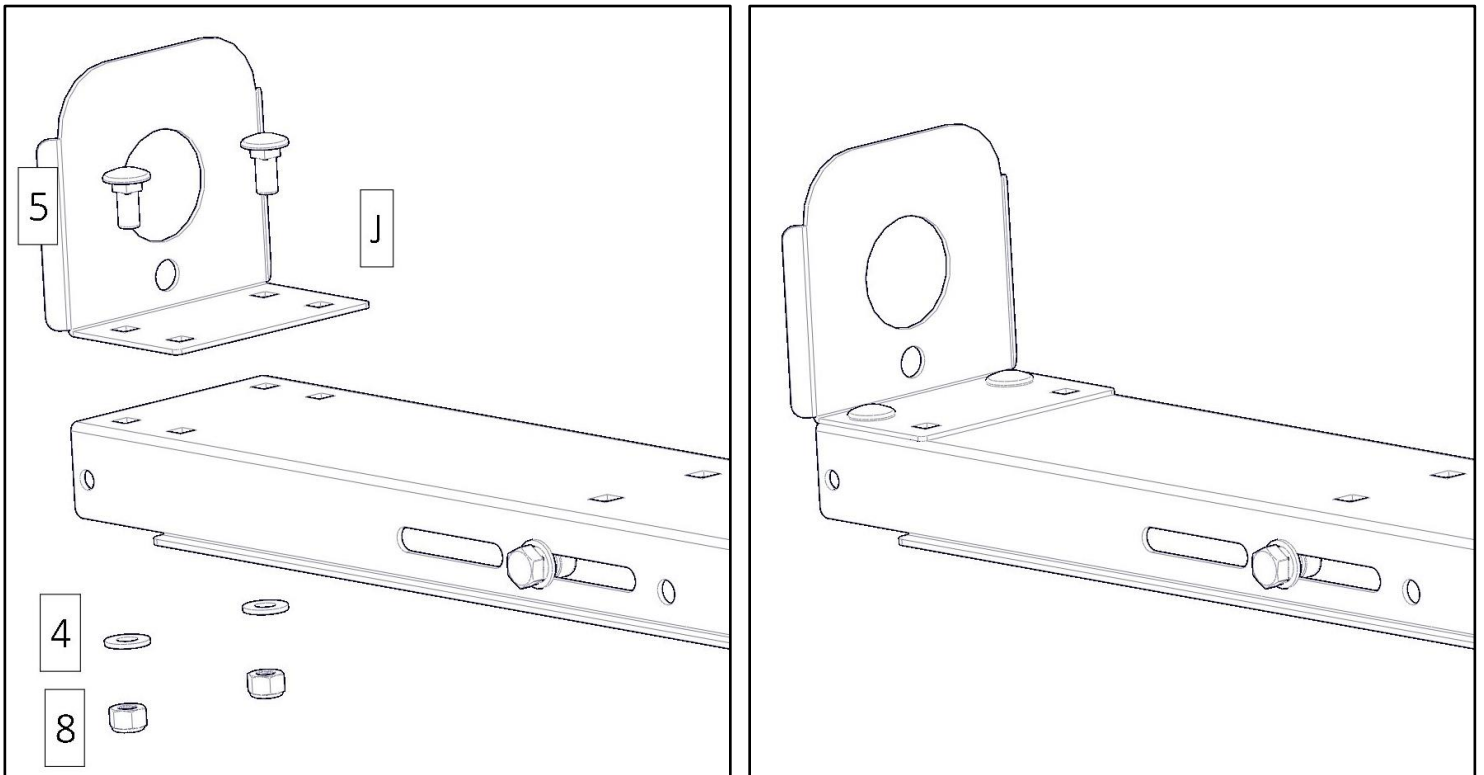

## Step 2 – Install Front and Rear Bow

- Place rear bow assembly (B) onto previously installed mount feet at the rear of the Van.
  - **\*\*Make sure the bow is centered along the van\*\***

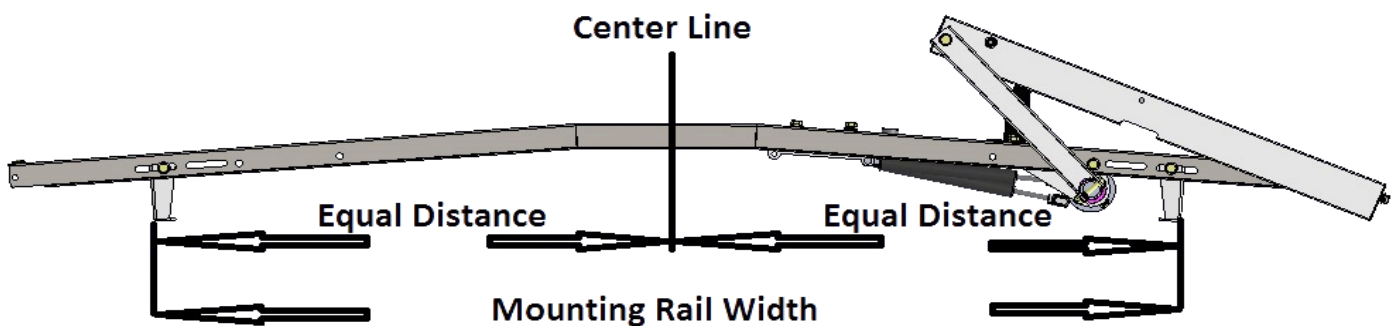

- Bolt to feet using .375" x .75" hex head bolts, .375 split lock washers and .375 flat washers.

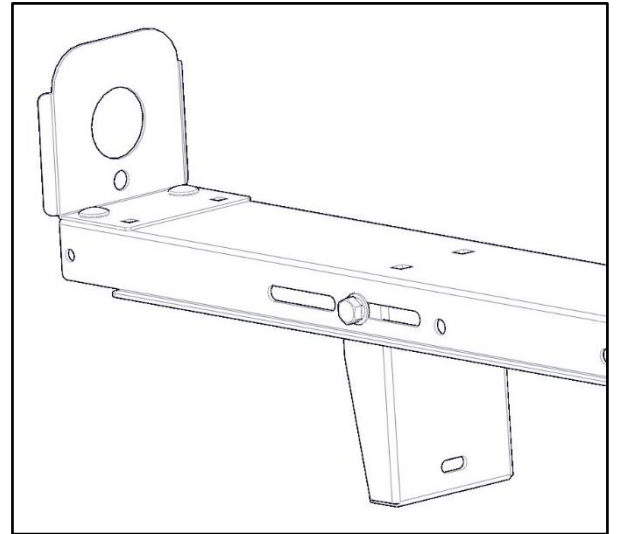
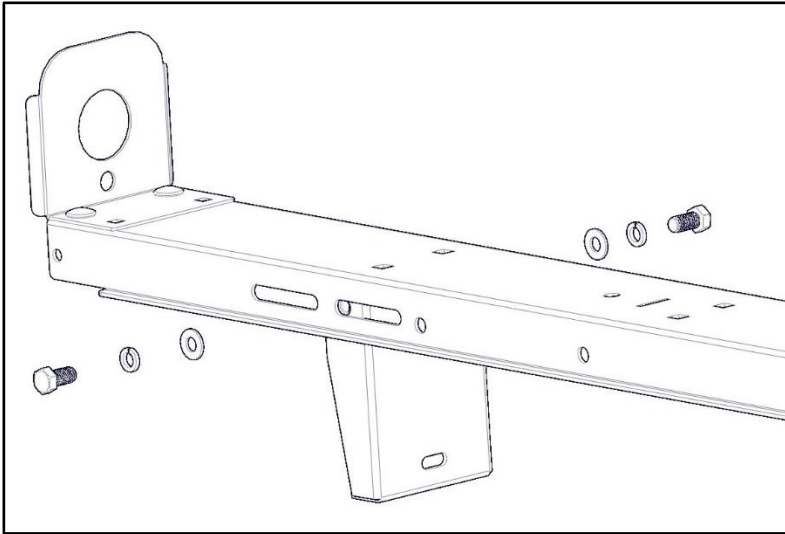

Repeat on other side.  
Repeat using front bow.

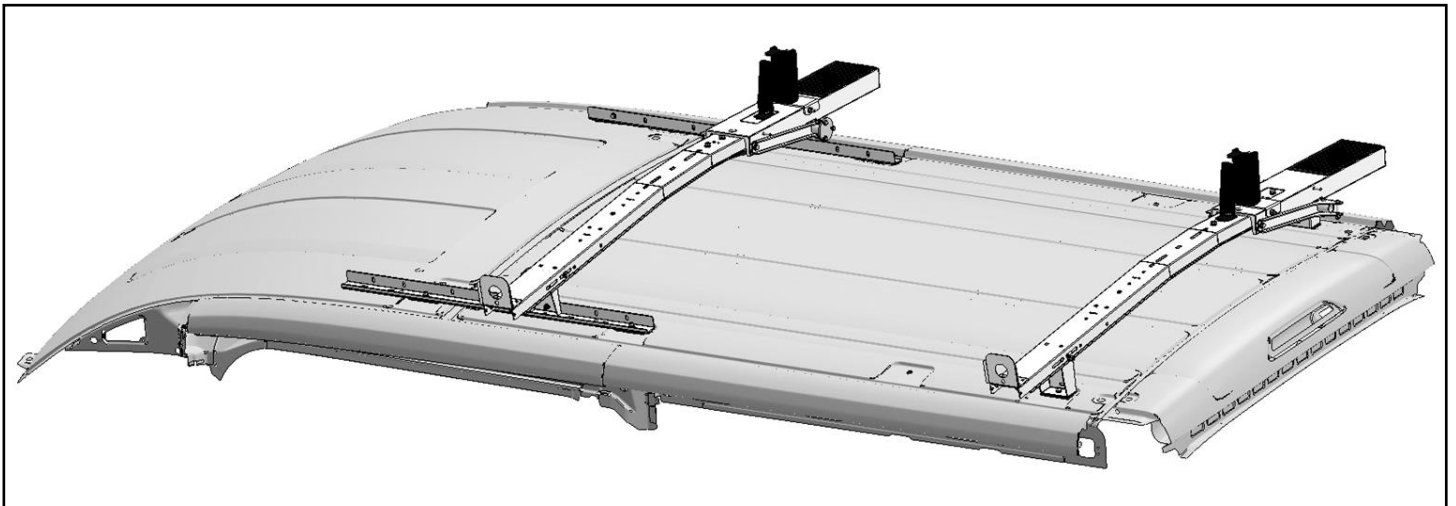

### Step 3 – Torque Tube Installation

**\*\*BE SURE THE BOTH FRONT AND REAR LADDER PANS ARE ALL THE WAY DOWN ON THE BOWS WHILE TIGHTENING\*\***

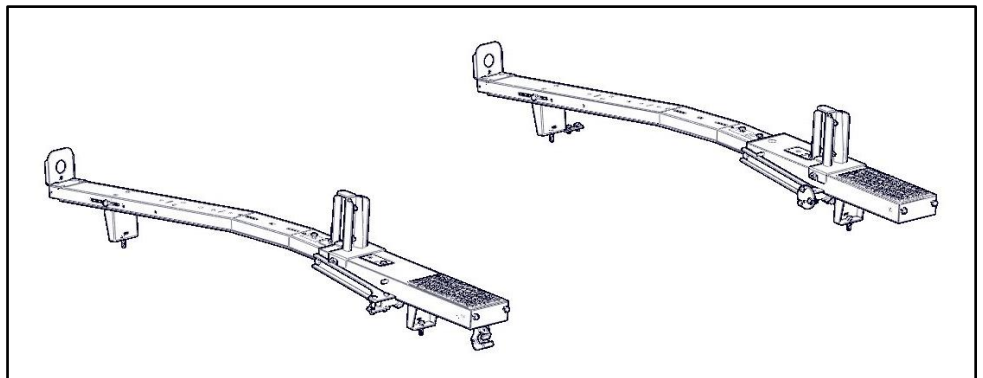

- Bolt Torque Tube(C) to Rear Bow Assy(B) using three .25" x .875" hex head bolts (3) six .25" flat washers(1) and three .25" nyloc nuts(2).

\*\*You may want to put a foam packing block under the front of torque tube (C) to make it level while tightening\*\*

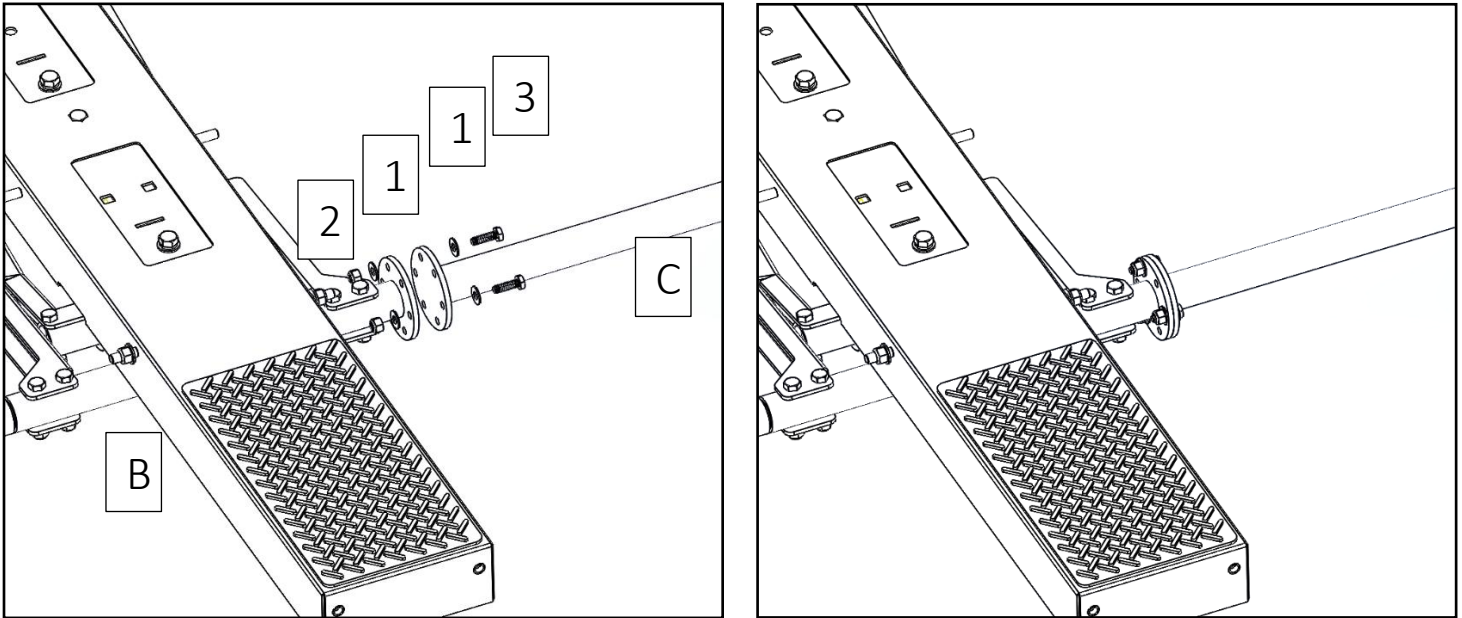

- Repeat process to bolt to the front bow assembly(A).

## Step 4 – Ladder Pan Support

### A.

- Assemble Support Tube(D&E). Put E6000(14) into tube swedge and around the bolt holes to prevent water from getting into tubes.

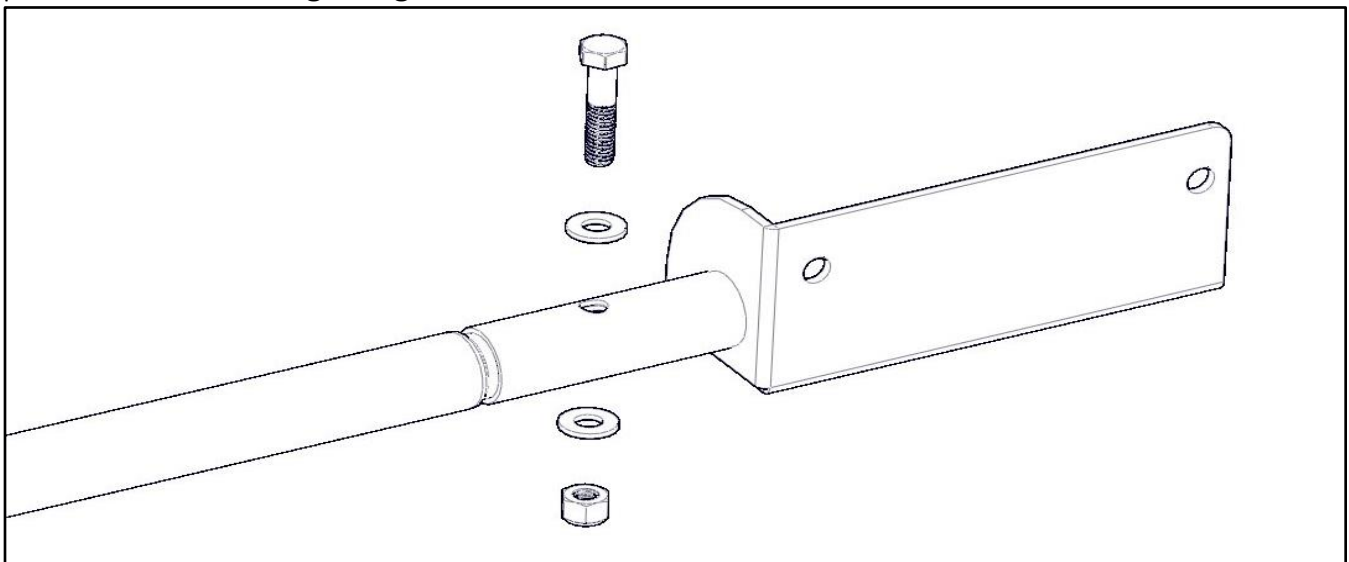

- Use .312" x 1.5" hex head, .312" flat washers and a .312" nyloc nut.

B.

- Attach Support Tube(D&E) to the Ladder pan as shown using .312" x .625 hex head (6) with .312" lock washers(7) and .312" flat washers(4).
- Repeat at front and rear bow.

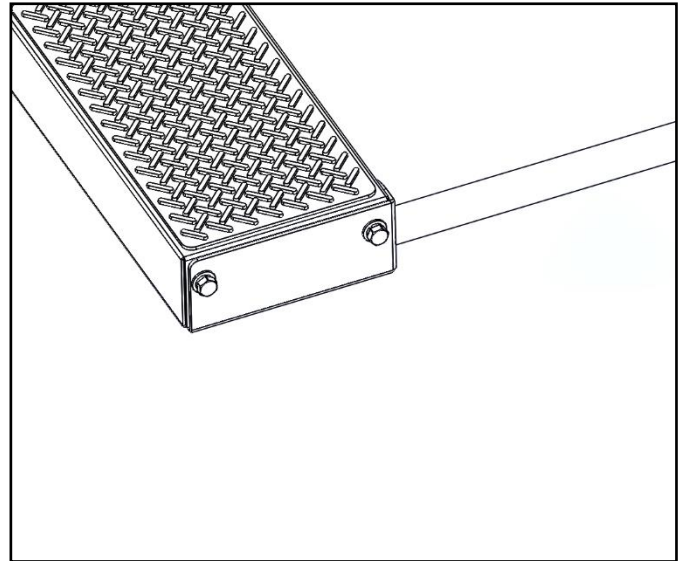
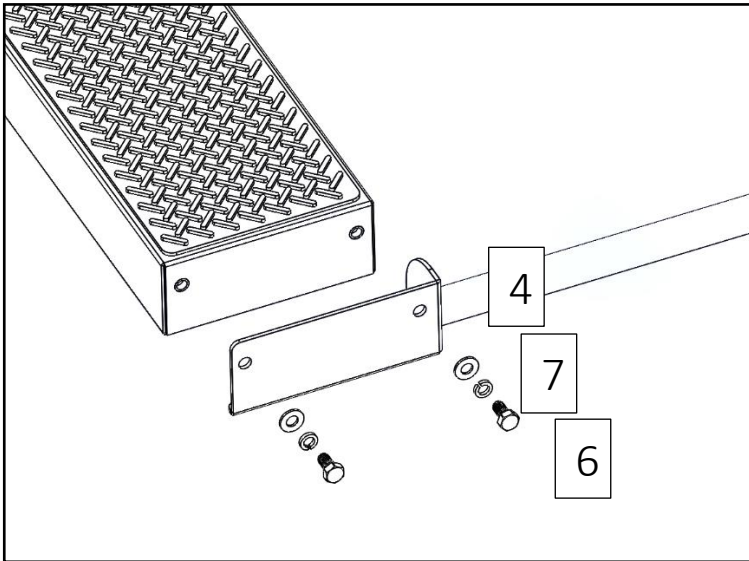

Step 5 – Ladder Stops and Hooks

- On the front bow (A), remove 3/8"x3/4" bolt, 3/8" split lock washer and 3/8" flat washer from shown location and install Ladder Stop(I)

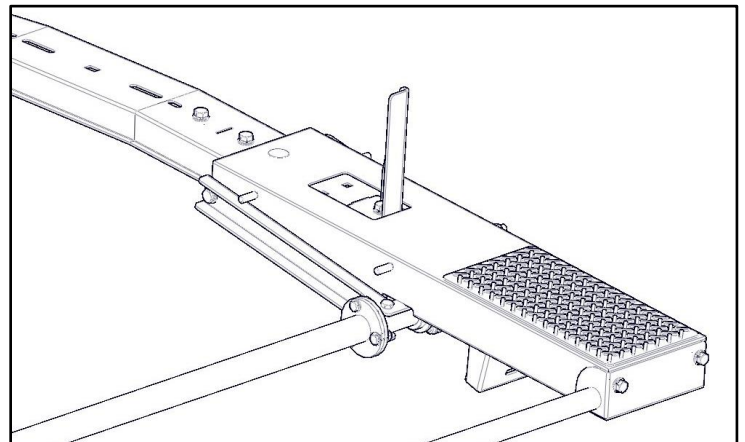
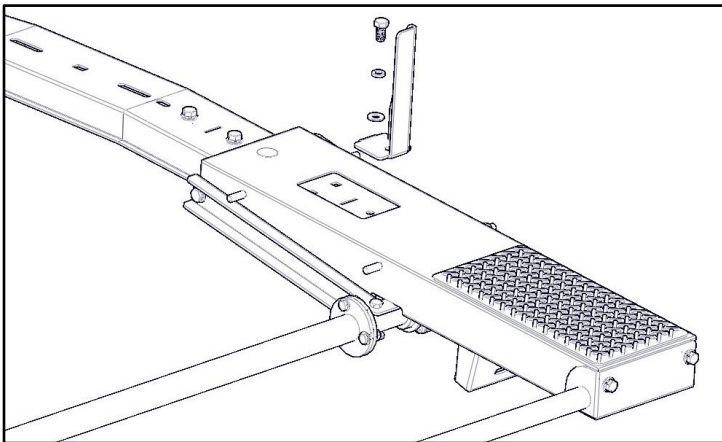

- Bolt Ladder Hook (H) to the lower position where the pem studs are installed. Use a .312 flat washer and a .312 nyloc nut .
- Repeat on both sides of ladder hook (H).

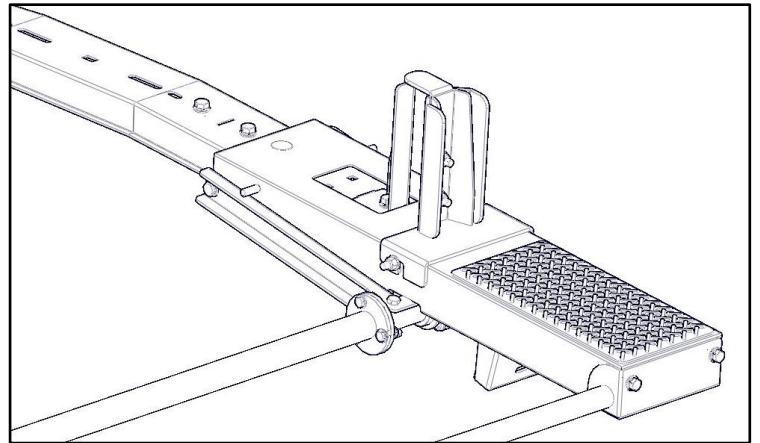
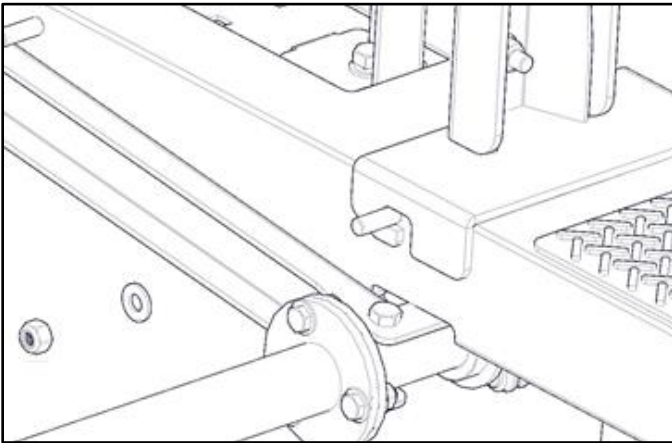

- If using an “Extension Ladder” put the Ladder Stop (I) at the same location on the Front & Rear Bow Assy.(A&B).

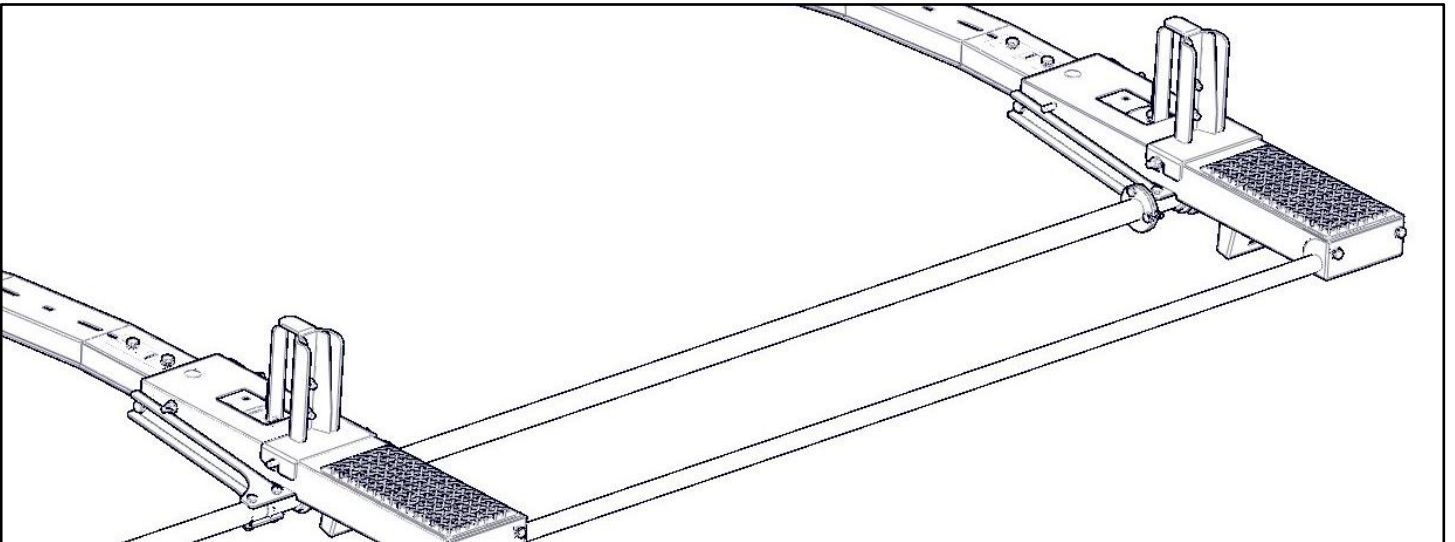

### Step Ladder Set-Up

- If installing for a “Step ladder”, The ladder hook (H) and the ladder stop (I) change positions on the rear bow.
- Both of these parts move higher up on the bow and are installed using the other pem studs.

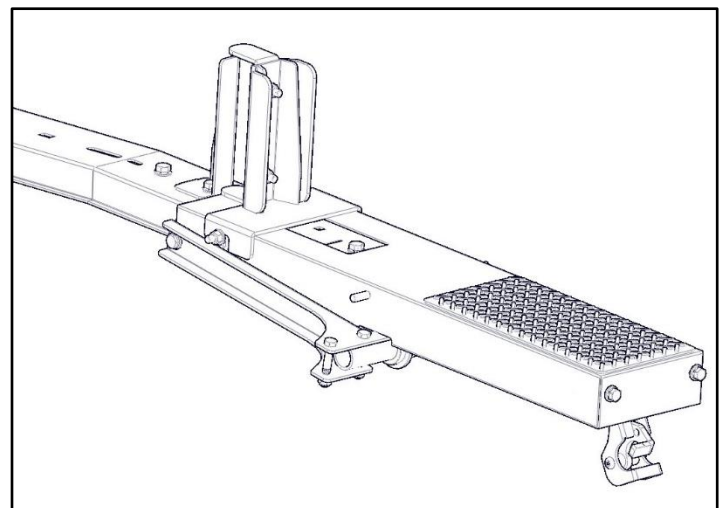
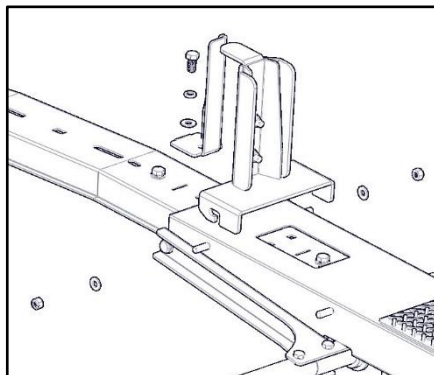



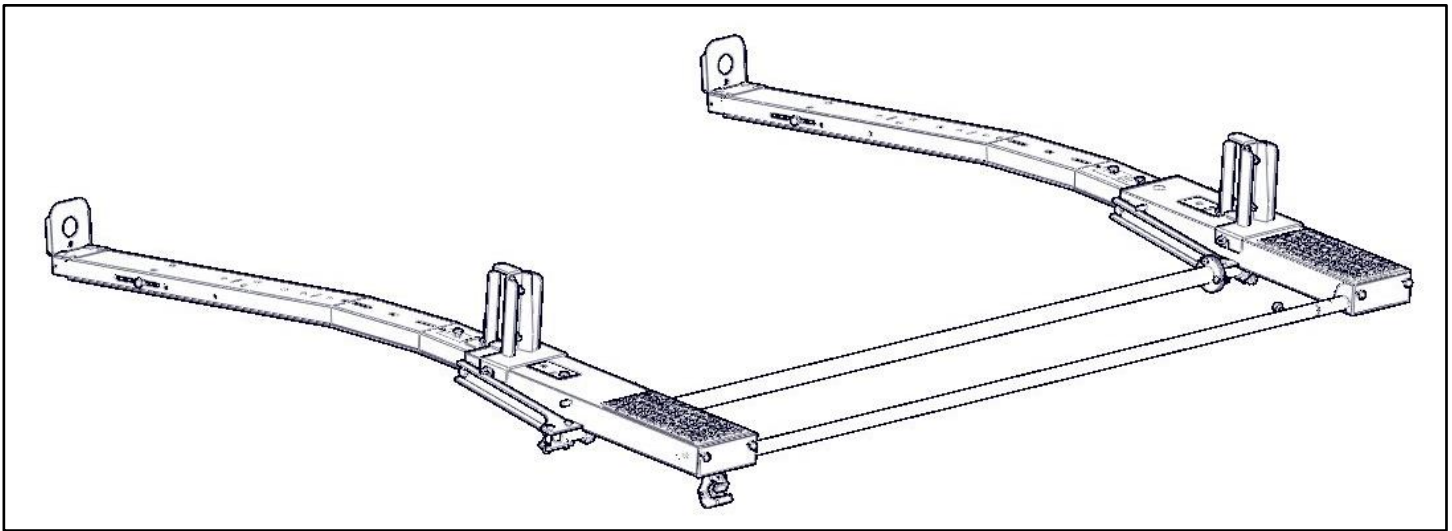

### Step 6 – Installing Handle

- Attach the handle (F) to the rear bow assembly.

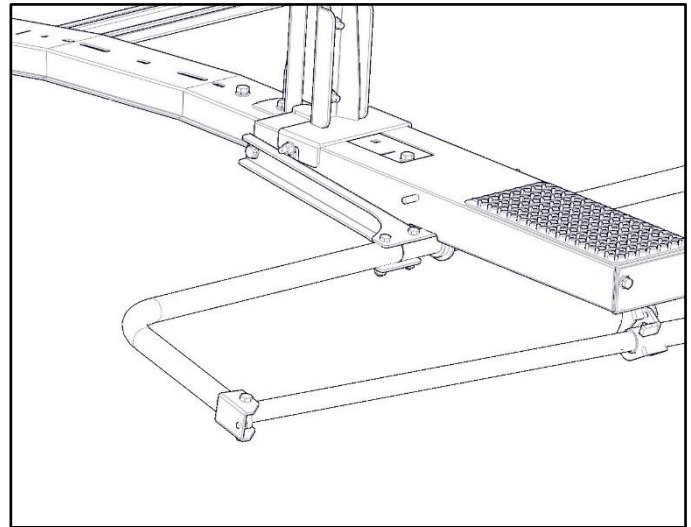
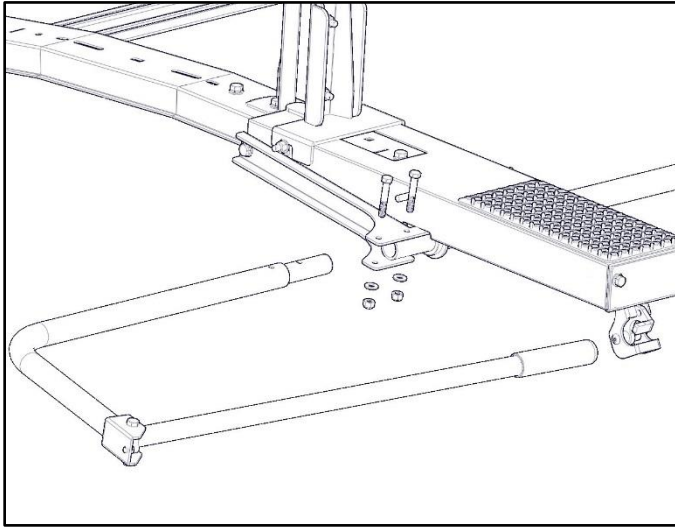

### Step 7 – Installing Rack

- If you built the rack on the bench you can now set the rack on the mounts as described in the mount kit.
- See step 2 for reference.

**GO BACK AND ENSURE ALL HARDWARE IS TIGHT**

Your installation is now complete.