KARGO MASTER®

WE PUT EVERYTHING WITHIN REACH.

Instruction Guide

409TD



*PLEASE READ ALL INSTRUCTIONS AND WARNINGS PRIOR TO ASSEMBLING,
INSTALLING, AND USING THIS PRODUCT*

Warning



Always check for wires, fuel tanks and lines, brake lines and other important vehicle functionality items prior to drilling and installing all products.



Tools Needed

13mm Wrench and Socket	1/2" Wrench and Socket
5mm Allen Hex	9/16" Wrench and Socket





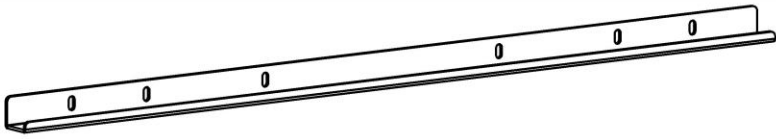
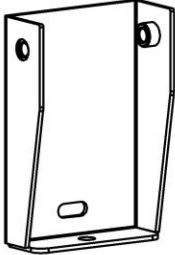
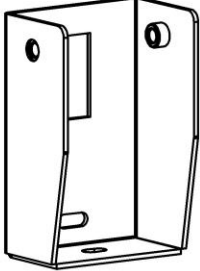

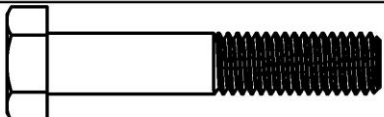
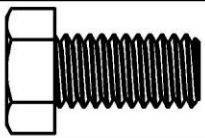

Before You Begin

- Read ALL instructions prior to installation.
 - Mount locations will vary based on van.
 - Be sure to put sealant around exposed threads in roof. Seal between the roof and the rubber pad. Apply some sealant on the threads of all bolts going into the roof.
-

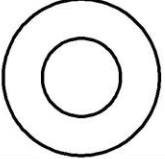
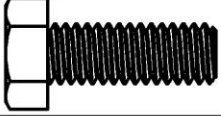
Parts

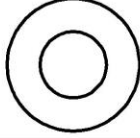
ITEM NO.		PART NUMBER	DESCRIPTION	QTY.
A		4A901-10-001	Front Rail	2
B		13-03105	Tall Foot	2
C		4090T-10-R2	Large Foot	2
D		4A9ST-00-001	Rear Mount Bracket	2
E		T249-01	Black Nylon Block	4
		18-409TD-R2	Hardware	1

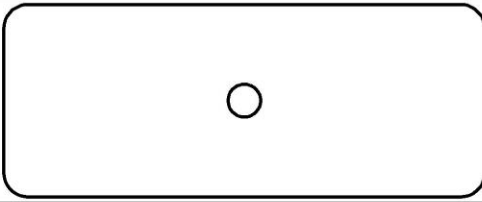
Hardware

ITEM NO.	TO SCALE	PART NUMBER	DESCRIPTION	QTY.
1		95327A569	M8x1.25 x 45mm Hex Head	4
2		92865A622	3/8" x 3/4" Hex Head	8
3		91102A760	3/8" Split Lock Washer	8
4		90126A031	3/8" Flat Washer	8
5		92865A582	5/16" x 7/8" Hex Head	4
6		95615A160	5/16" Nyloc	4
7		90126A030	5/16" Flat Washer	12
8		91102A755	5/16" Split Lock Washer	4
9		91263A845	M8x1.25 x 30mm Flat Head	2
10		T249-02	Rubber Scale 1:2	8
		BH-821	Sealant	1

Ford Transit (EXCLUDING High Roof Extended)

Step 1 – Rear Mounting

- Locate the threaded inserts at the rear of the van. Plugs will need to be removed.

130" Wheel Base

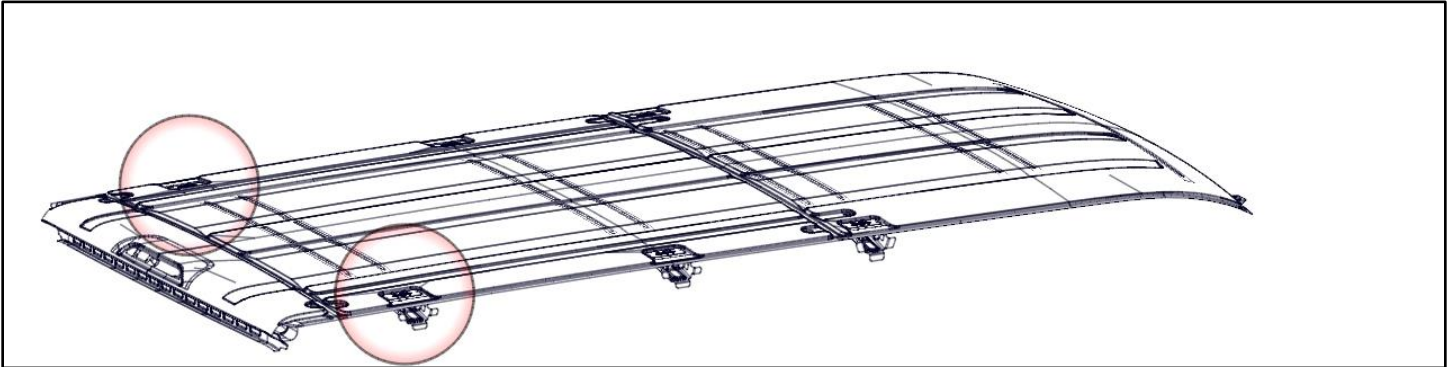

148" Wheel Base

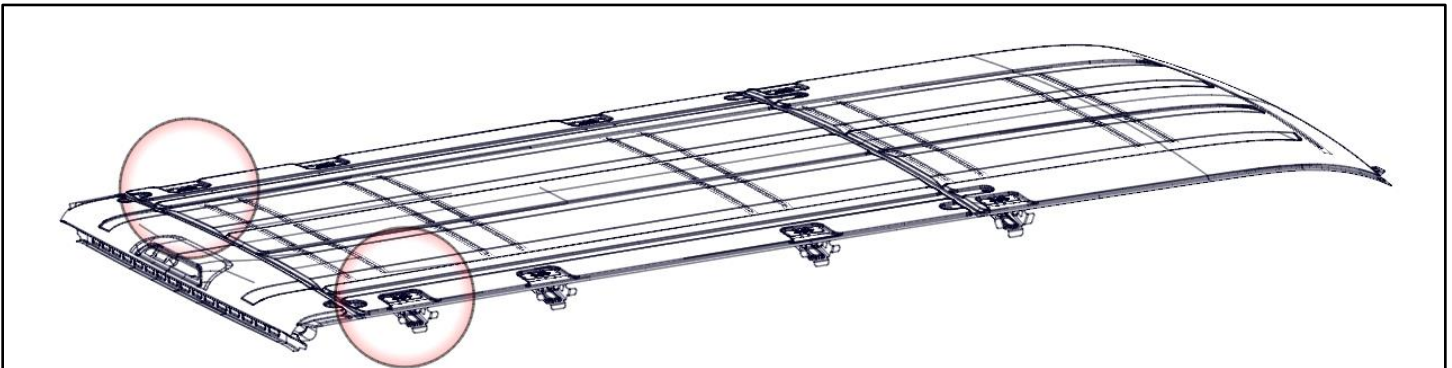

**** Place sealant around the exposed holes in the roof of the van under the rubber pads to ensure no water can leak into the cabin of the van. ****

- Attach the rear mount bracket using M8 x 30mm flat head bolts. Place two rubber pads between the bracket and the roof of the van. The bracket should be parallel with the length of the van and the flange should be to the inside.
- Tighten. (Passenger side shown)

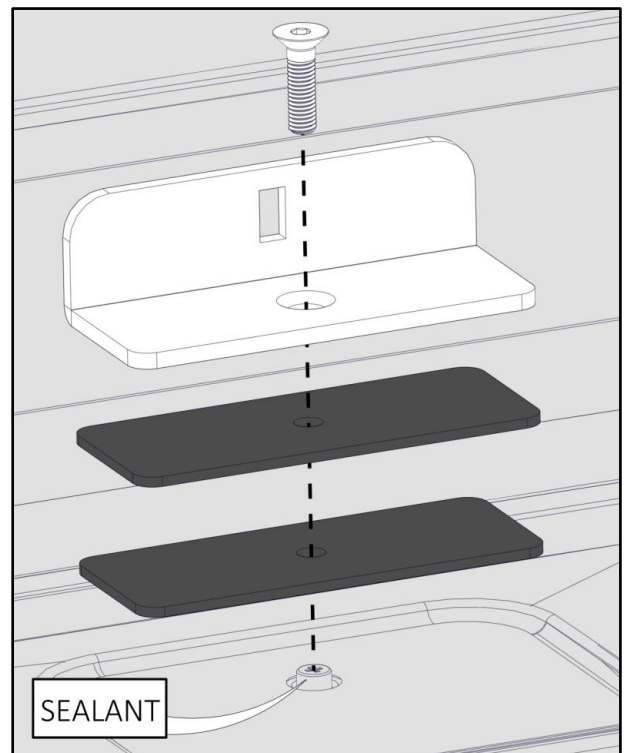

Step 2A – Front Mount on 130” Wheel Base (Low/Mid Roof)

- Locate the other threaded inserts at the front of the van. Remove plugs.

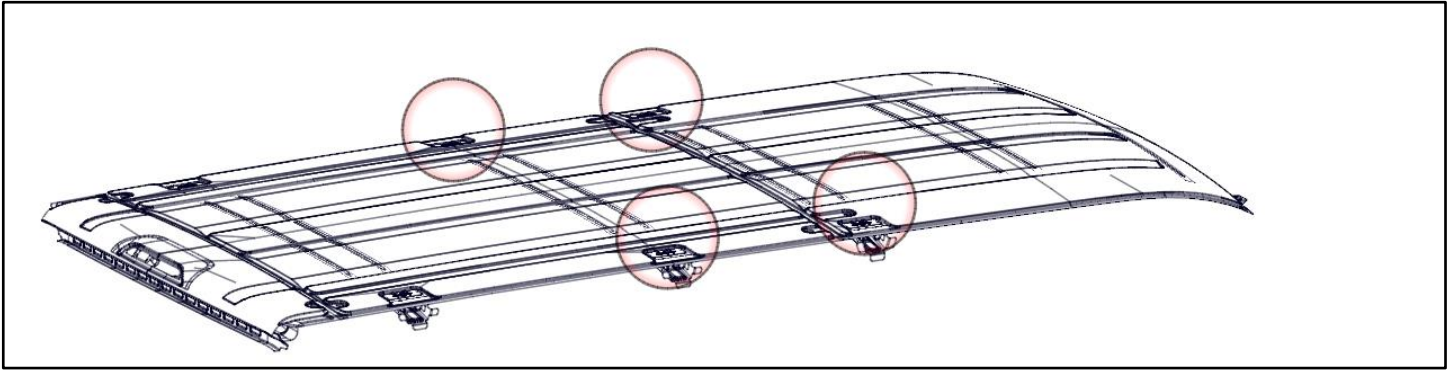

**** Place sealant around the exposed holes in the roof of the van under the rubber pads to ensure no water can leak into the cabin of the van. ****

- Place the long mount rail with the tall flange towards the center of the van on top of the rubber pad and black nylon block.
- Bolt through farthest rear slot in the rail and the corresponding front slot using M8 x 45mm bolts with lock washers and flat washers.
- The rail should be offset to the front of the van.

(Passenger side, rear most mount on the rail shown)

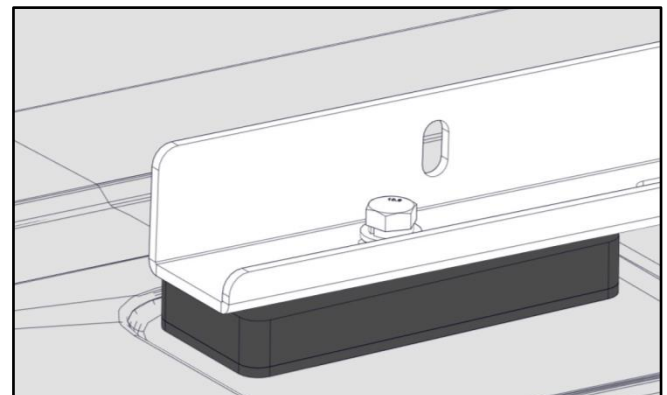
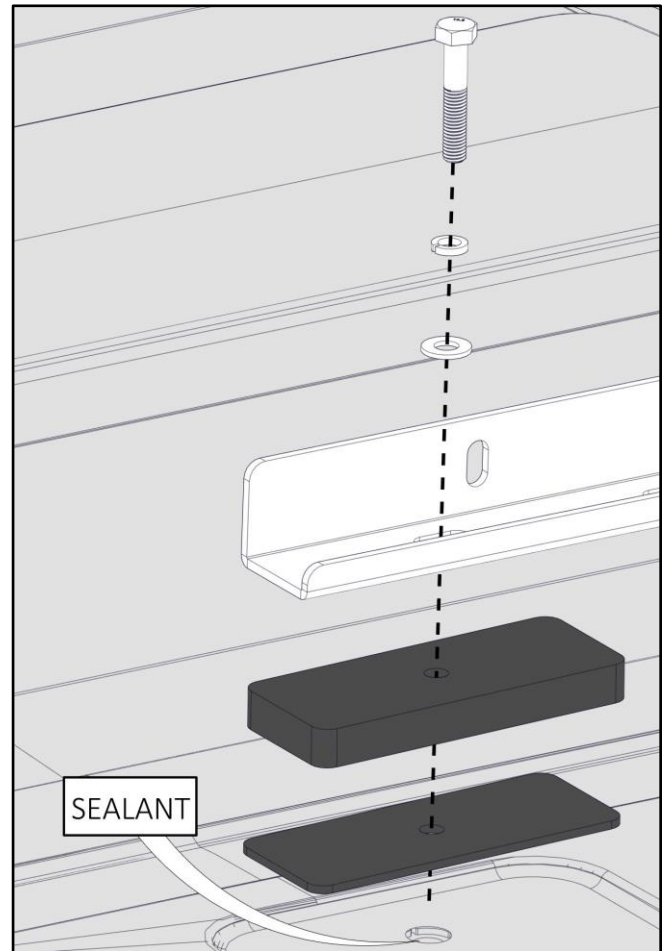

- Passenger side shown, repeat on driver side.
- Snug tighten.

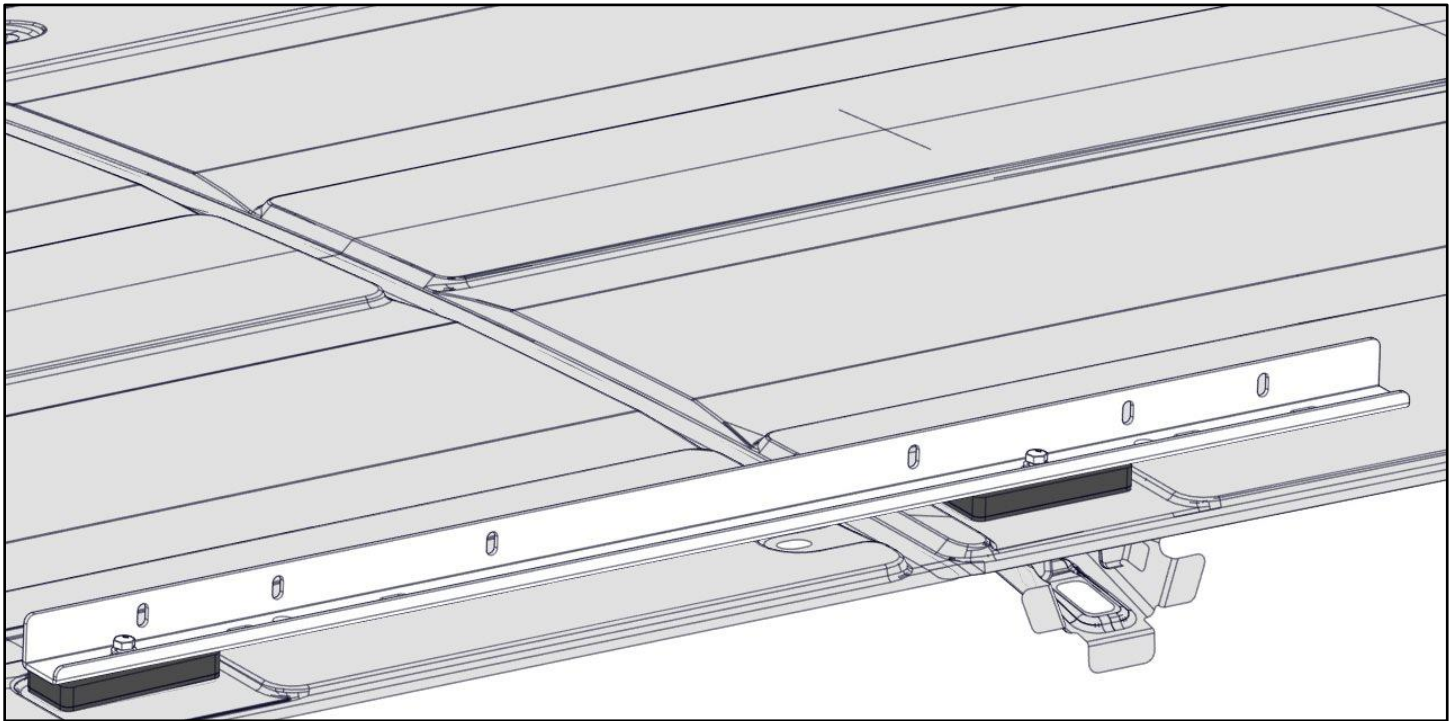
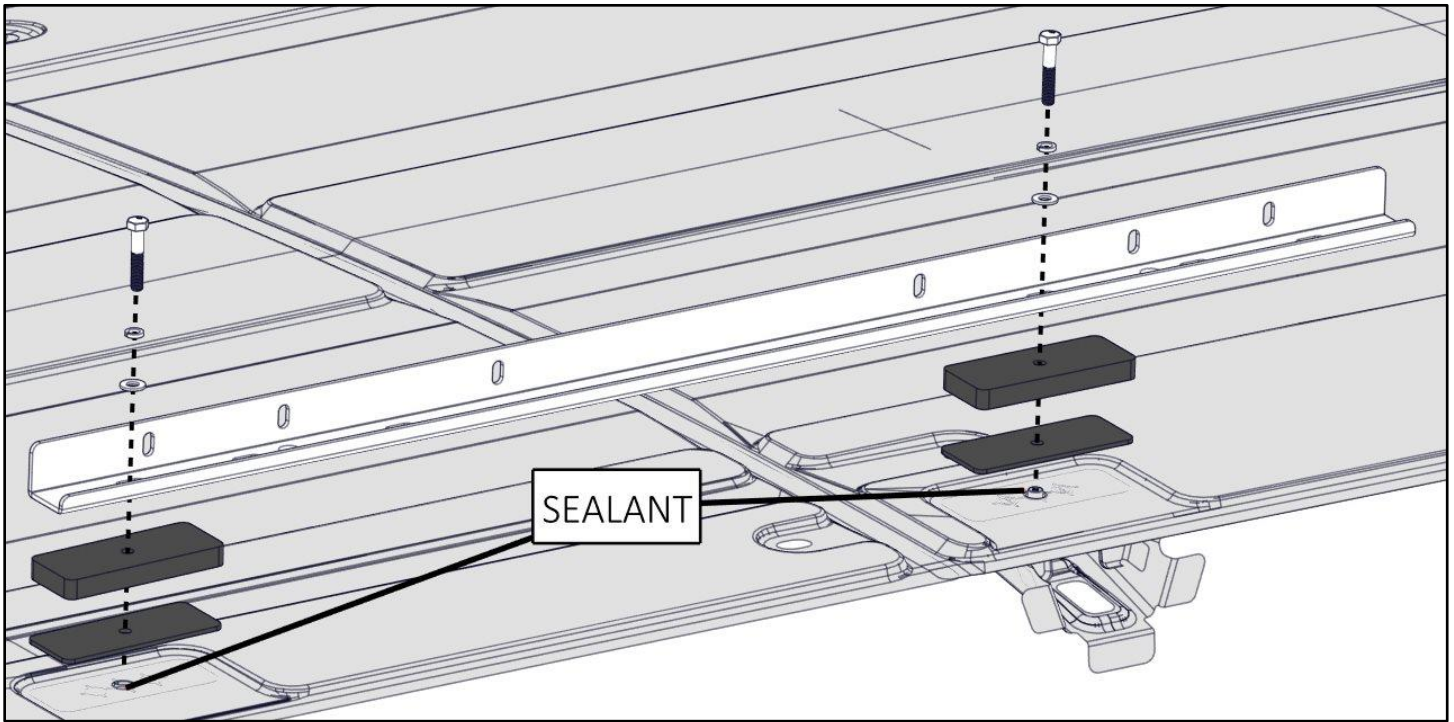

Step 2B – Front Mount on 148” Wheel Base (Low/Mid/High Roof excluding Extended)

- Locate the other threaded inserts at the front of the van. Remove plugs.

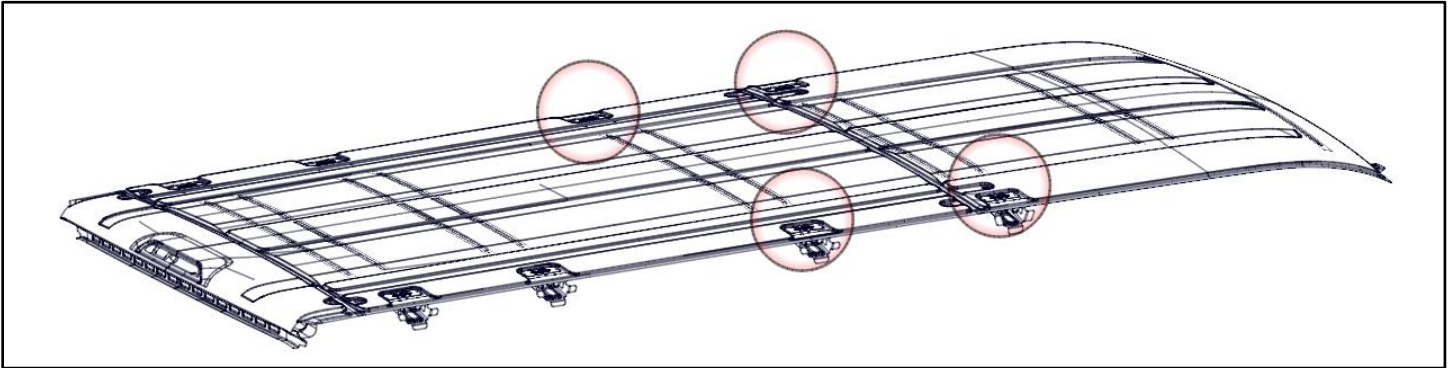

**** Place sealant around the exposed holes in the roof of the van under the rubber pads to ensure no water can leak into the cabin of the van. ****

- Place the mount rail with the tall flange towards center of the van on top of the rubber pad and black nylon block.
- Bolt through the farthest rear slot in the mount rail and corresponding front slot in the rail using M8 x 45mm bolts with lock washers and flat washers.
- The rail should be offset to the front of the van.

(Passenger side, rear most mount on the rail shown)

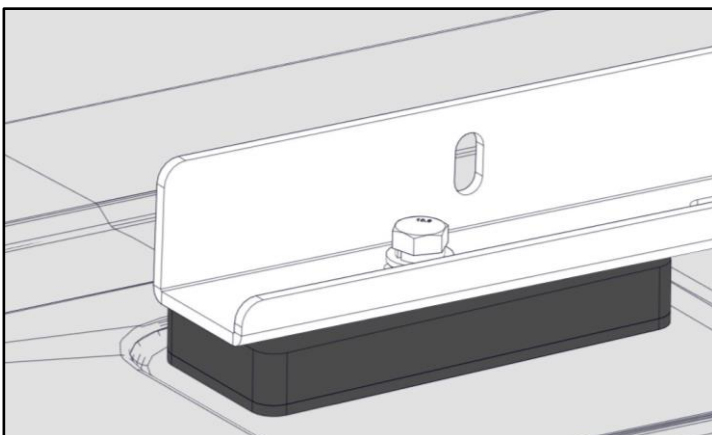
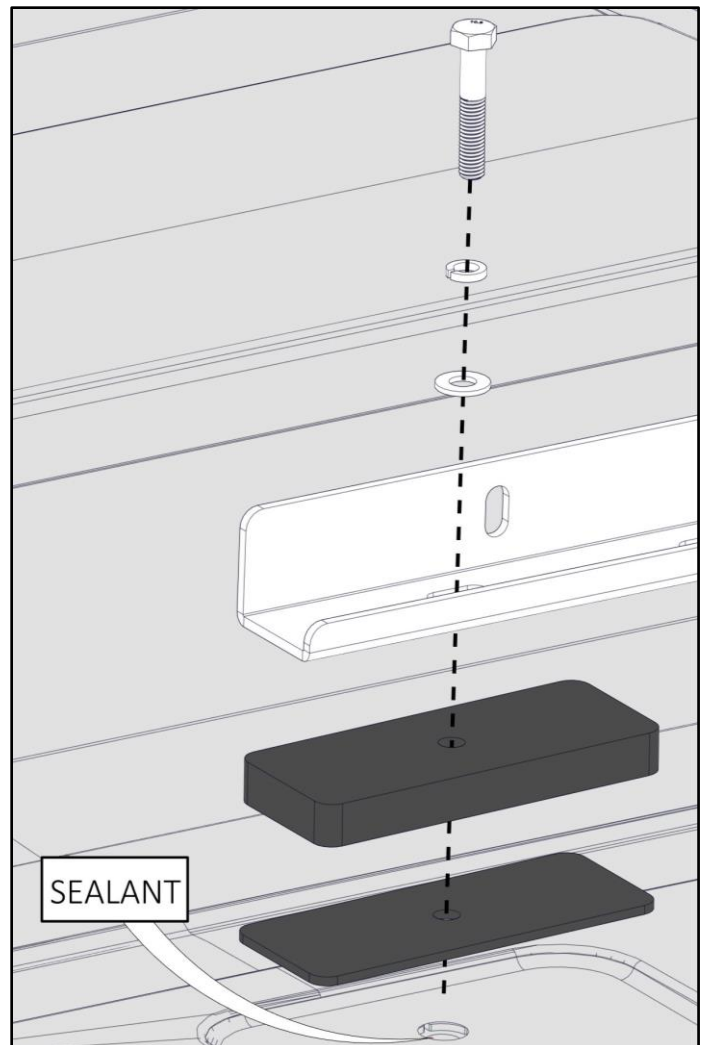

- Passenger side shown, repeat on driver side.
- Snug Tighten.

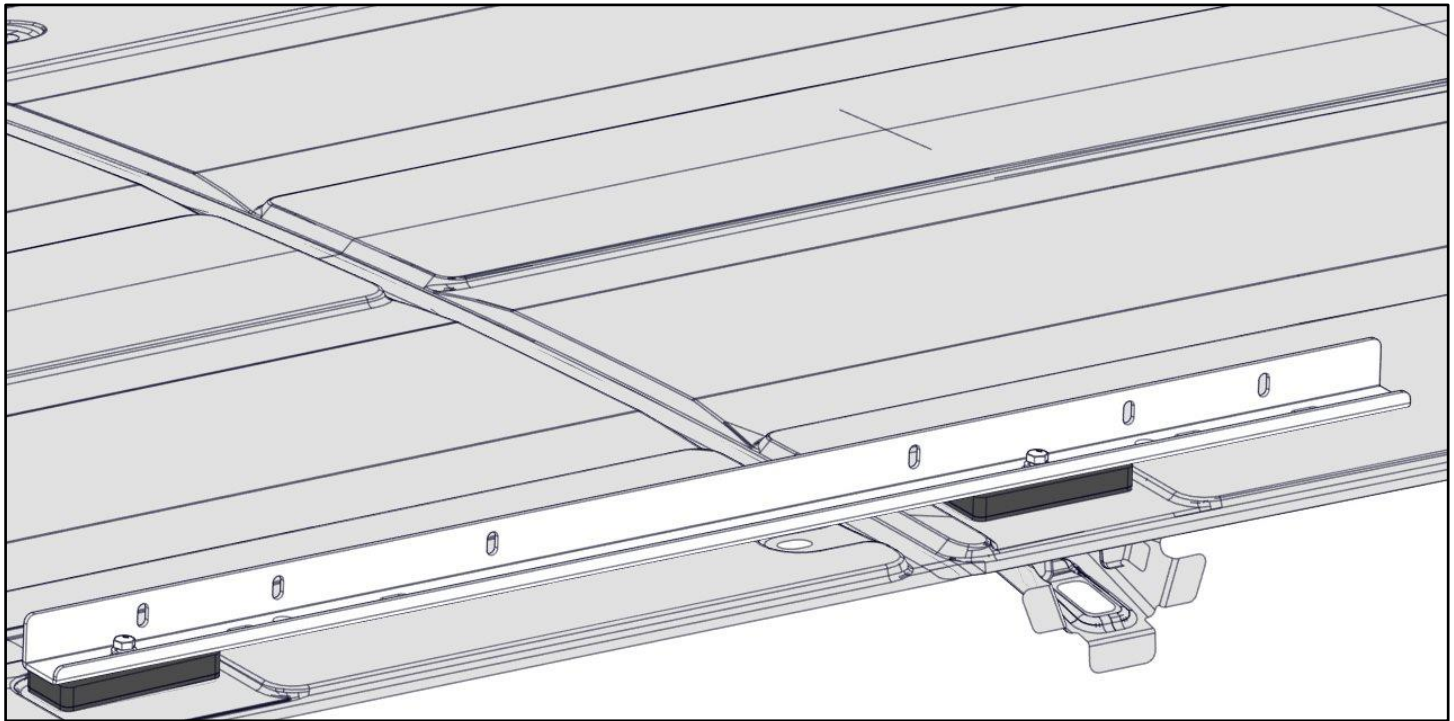
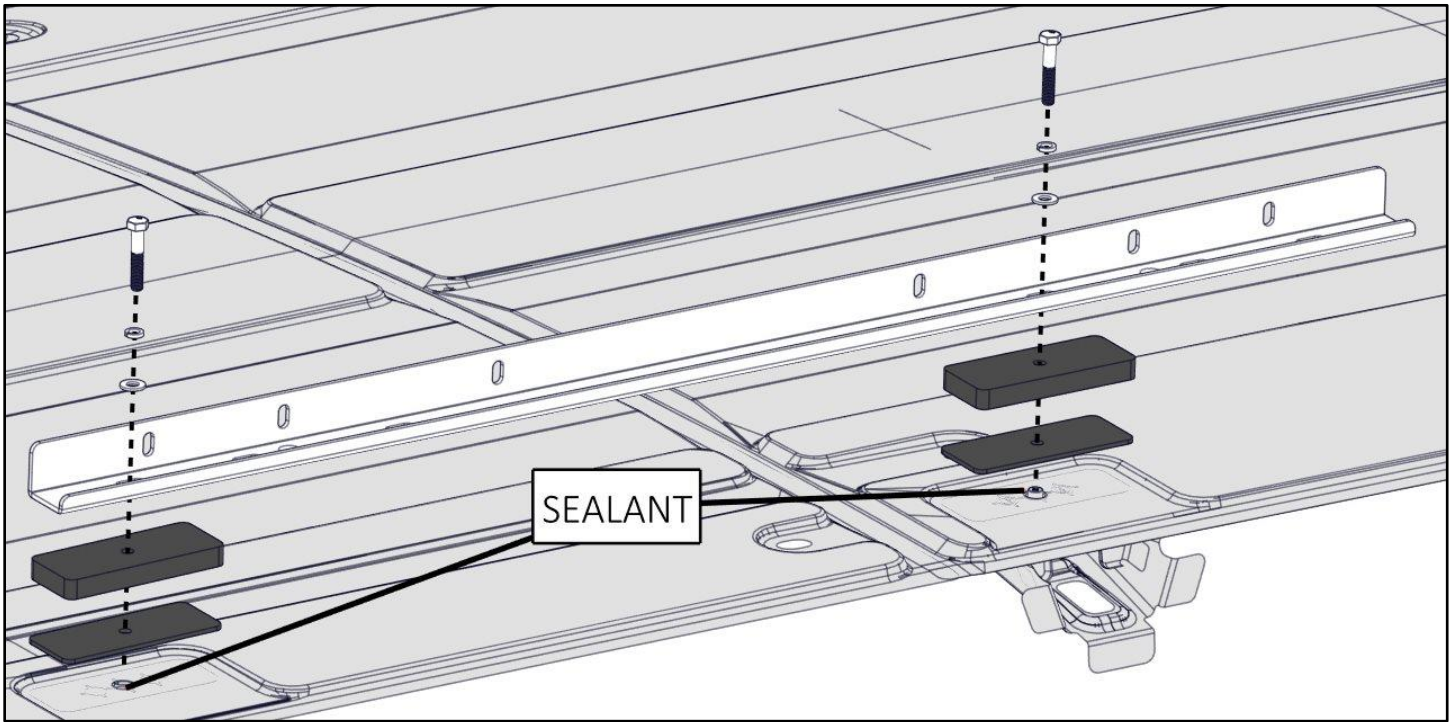

Transit 148" Wheelbase, High Roof, Extended

Step 3A - Extended - Rear Foot Mounting

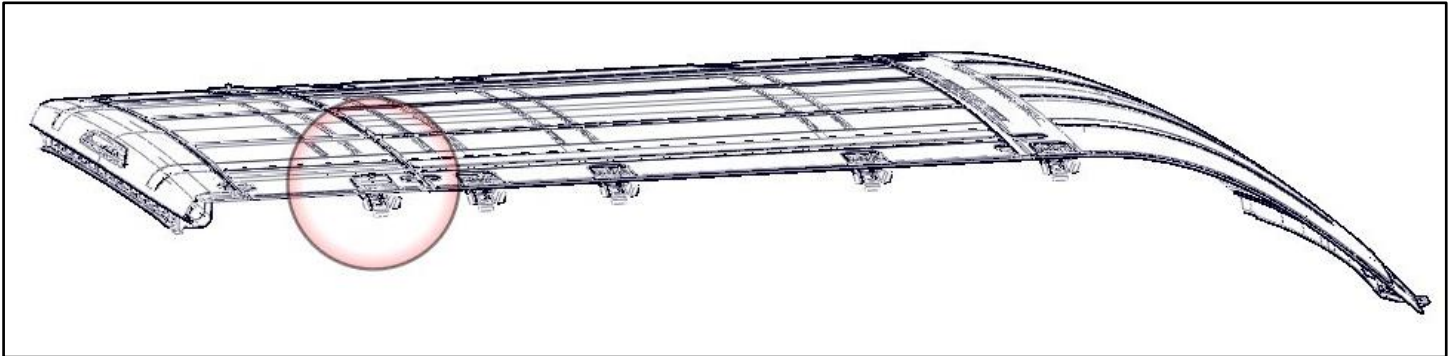

**** Place sealant around the exposed holes in the roof of the van under the rubber pads to ensure no water can leak into the cabin of the van. ****

- Mount rear mount bracket using M8 x 30mm flat head bolts. Place two rubber pads between the bracket and the roof of the van. The bracket should be parallel with the length of the van and the flange should be towards the center as shown.

(Passenger side shown)

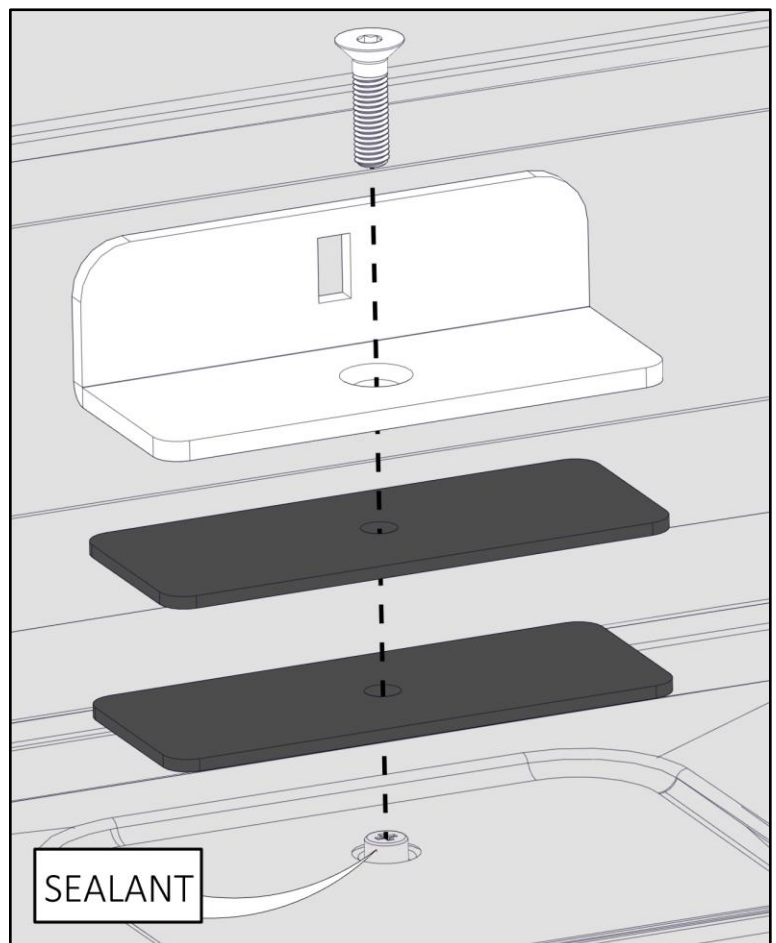

Step 3B - Extended - Front Mount

- Locate the other two threaded inserts at the front of the van. Remove plugs.

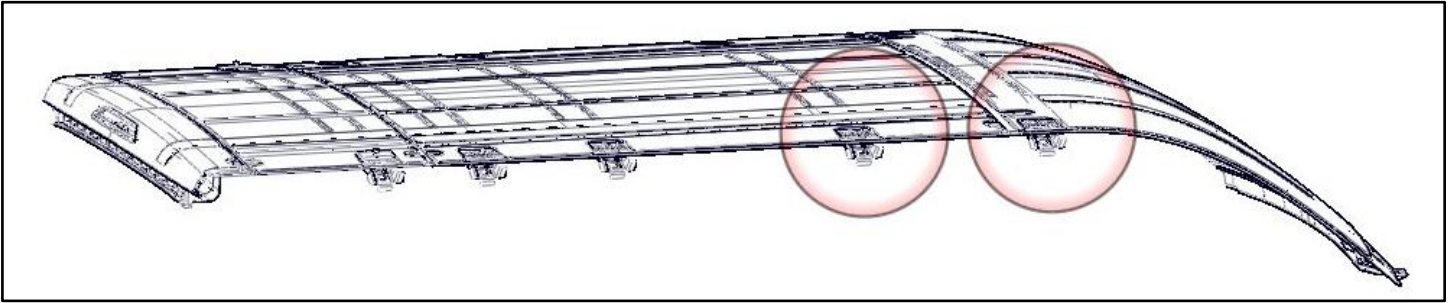

**** Place sealant around the exposed holes in the roof of the van under the rubber pads to ensure no water can leak into the cabin of the van. ****

- Place the long mount rail with the tall flange towards the center of the van.
- Bolt through the farthest rear countersunk hole and the 2nd slot from the front using M8 x 45mm bolts with lock washers and flat washers.

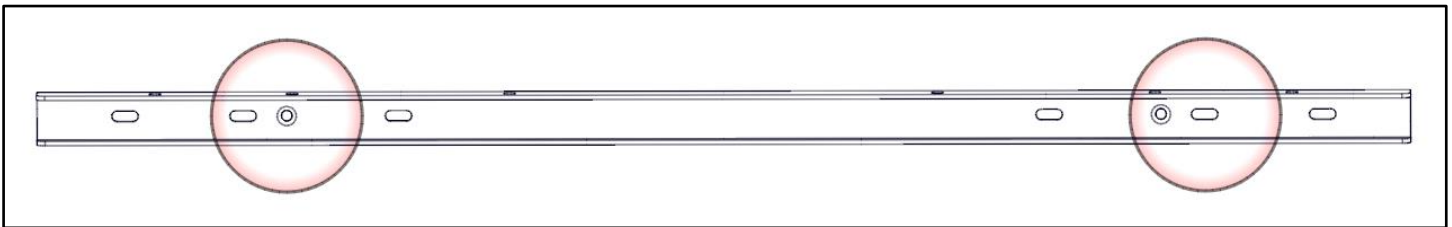

- The picture shown below is the rear most mount on the rail. (through the countersunk hole)
- Passenger side shown, repeat on driver side.
- Snug Tighten.

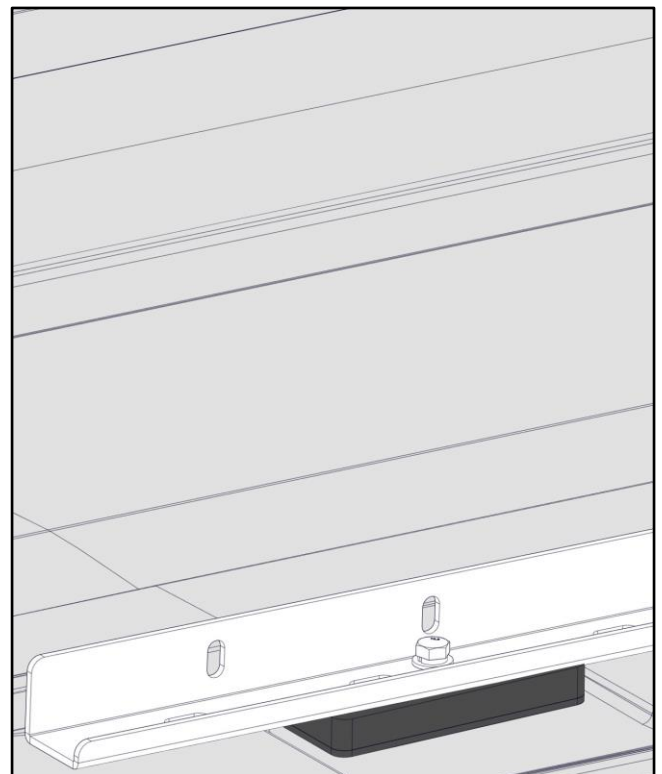
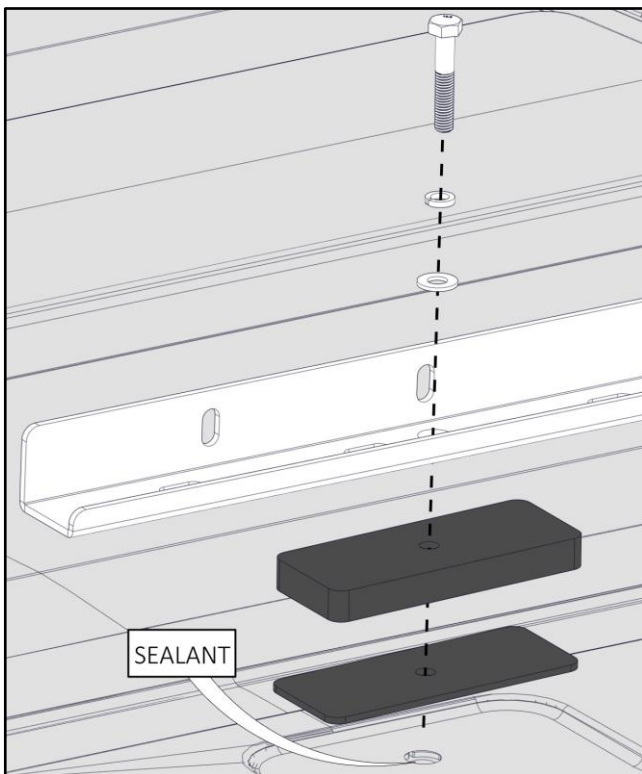

Step 4 – Install Rear Feet

- Bolt large foot (has a cut out) to the rear mount previously installed using 5/16" x 7/8" hex head bolt, two 5/16" flat washers and a 5/16" nyloc nut. (Passenger side shown without roof and rack for clarity)

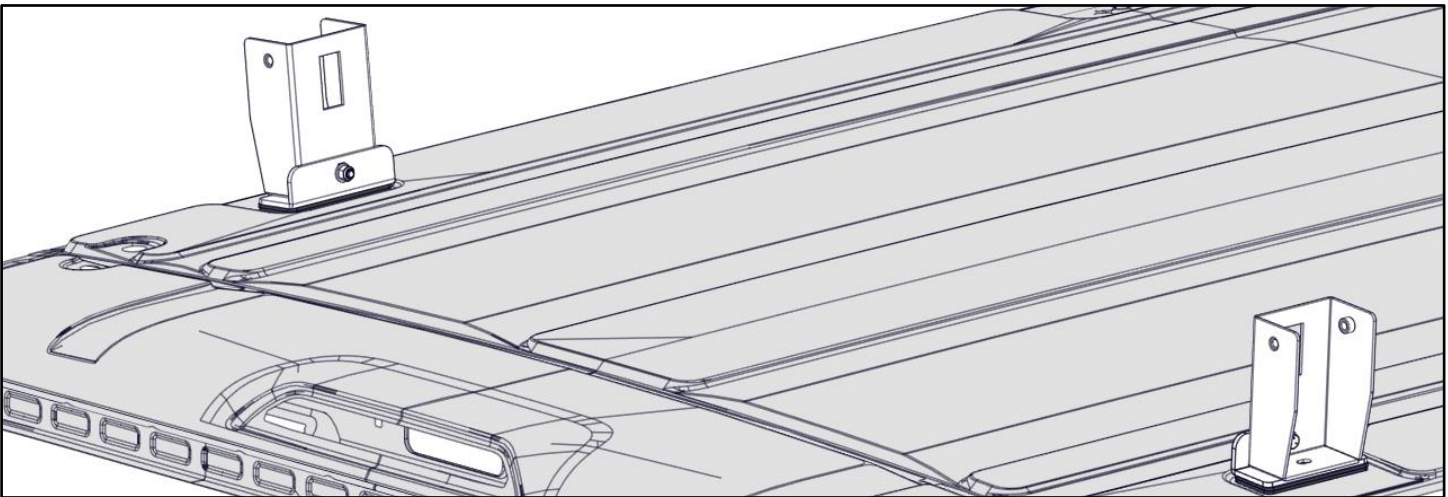
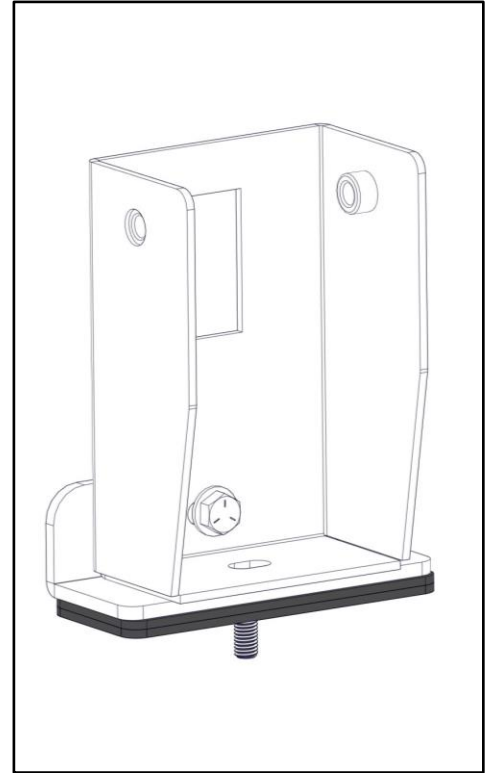
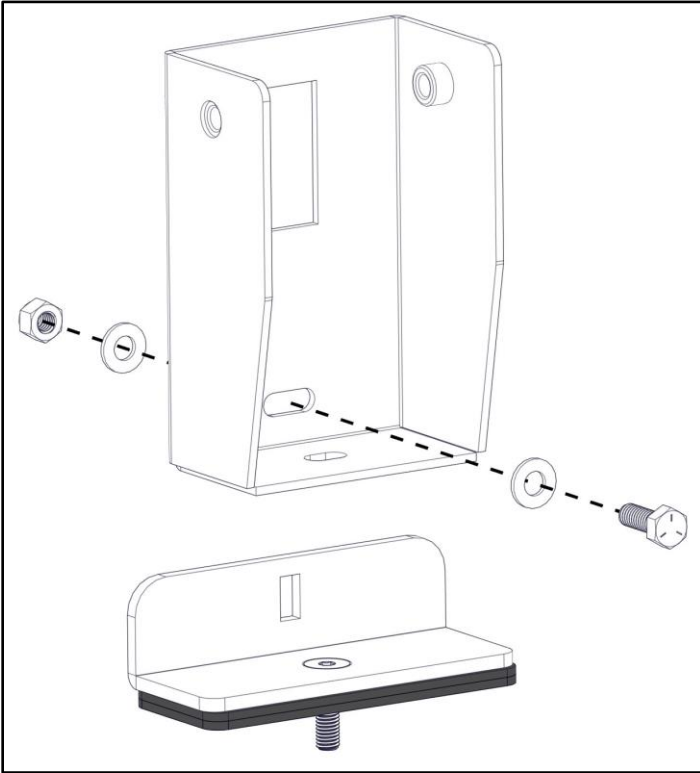

Step 5 – Install Front Feet

- Mount the tall foot to the previously installed rail using a 5/16" x 7/8" hex head bolt, two 5/16" flat washers and a 5/16" nyloc nut.
- Be sure the distance between the two feet closely matches the distance between the bows on the ladder rack being installed. The slot used on the front rail will vary from the picture below.

Note: One may choose to install the feet on the rack prior to installing onto the vehicle. It is the installers preference.

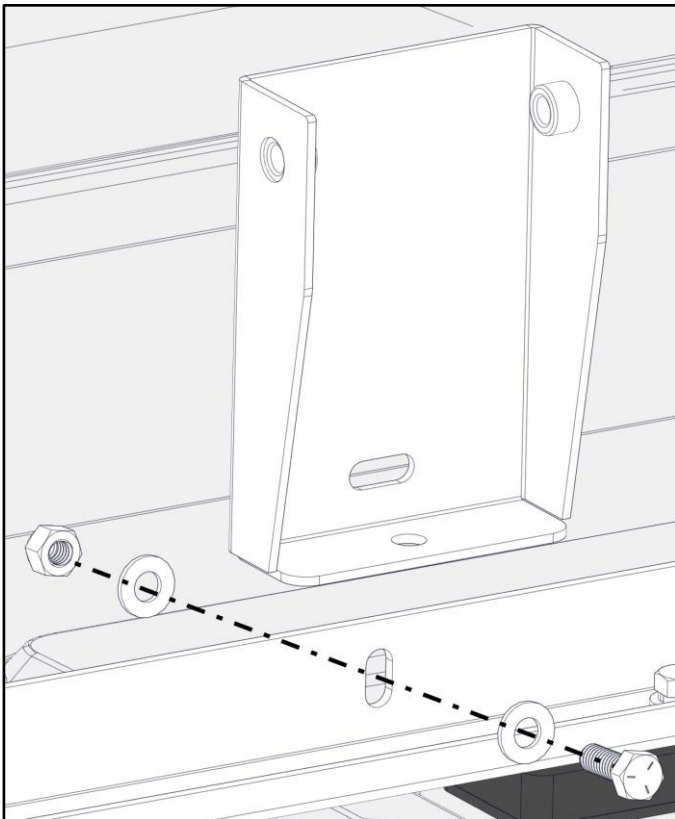
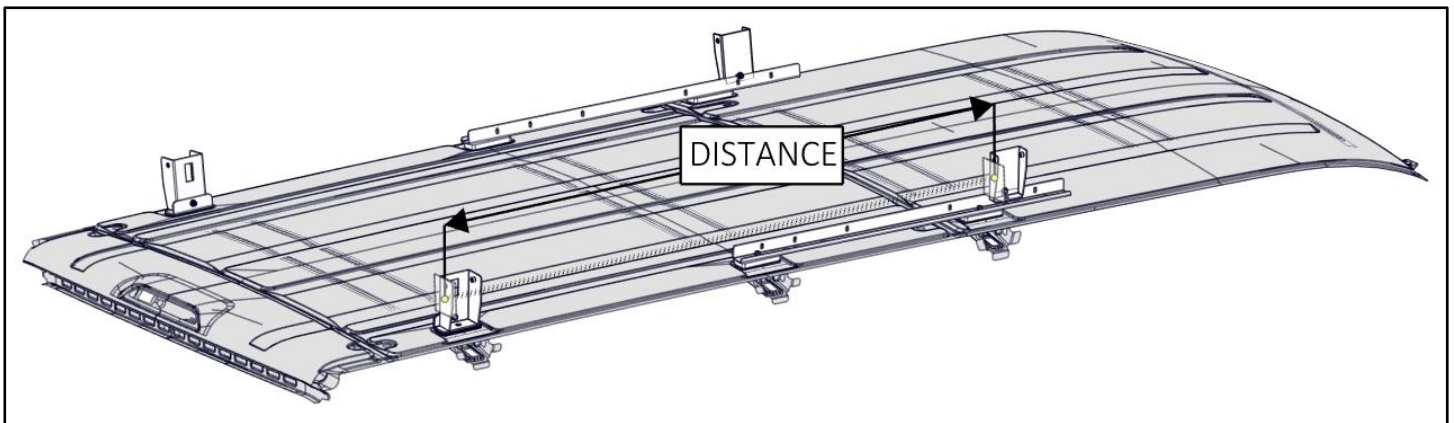

Step 6 – Feet to Rack

- Place assembled ladder rack on top of the previously installed feet.
- Measure width between the mounts on the van.
- Center the assembled rack on top of the installed feet. Align bow with the same slot on opposite ends.
- Bolt the feet to the bows as shown using 3/8" x 3/4" hex head bolts, 3/8" lock washers and a 3/8" flat washers.

Note: One may choose to install the feet on the rack prior to installing onto the vehicle. It is the installers preference.

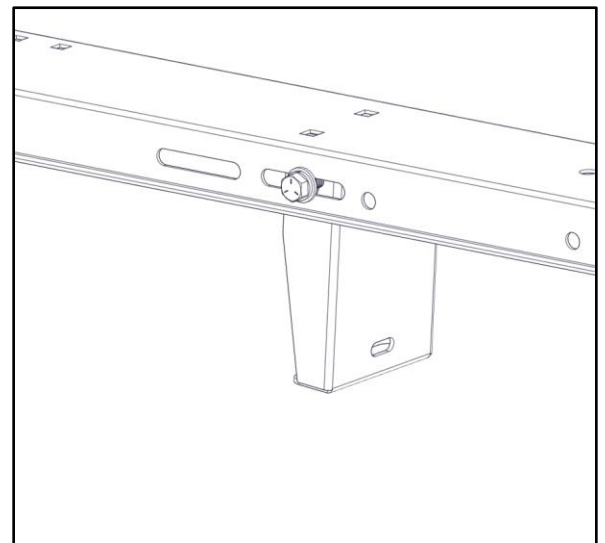
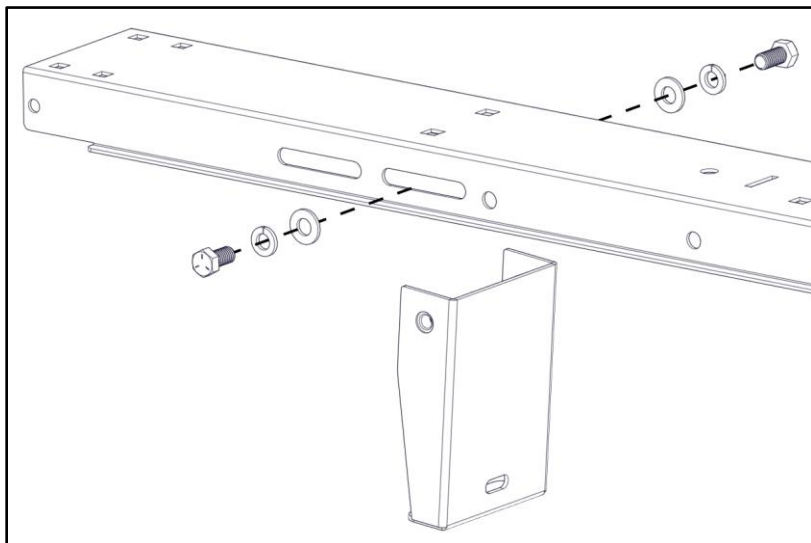
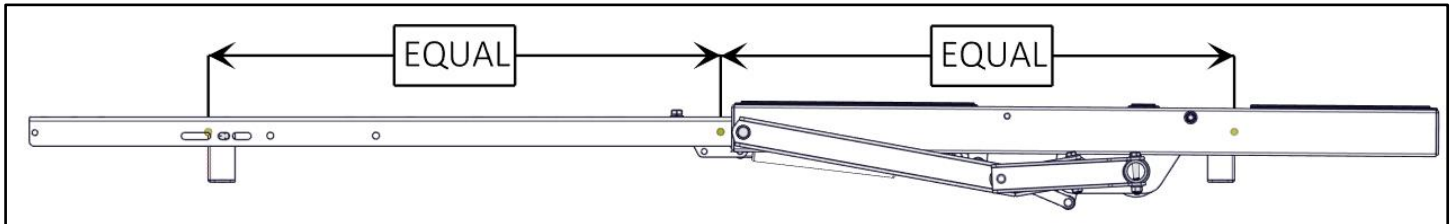
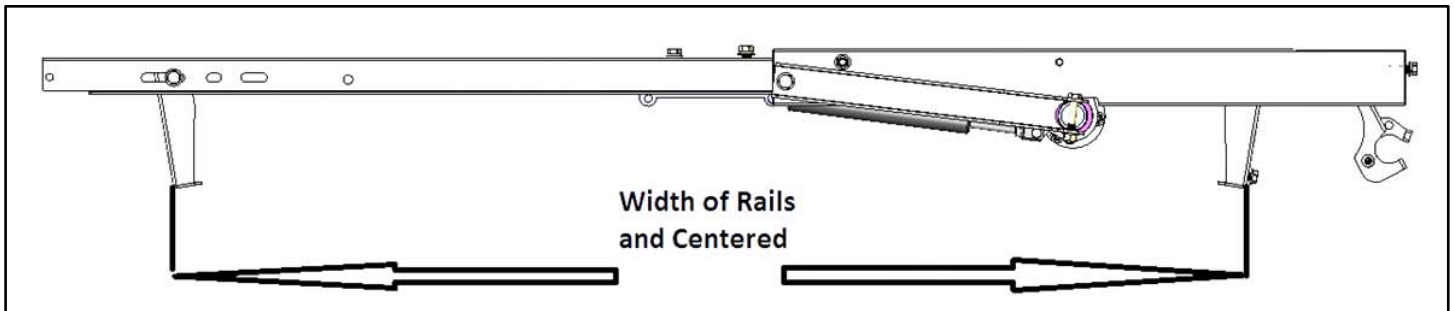

Go back and square the rack.

Ensure all hardware is tight. This includes into the roof, within the rack assembly and the mounting of the rack to roof mounts.

Your installation is complete.

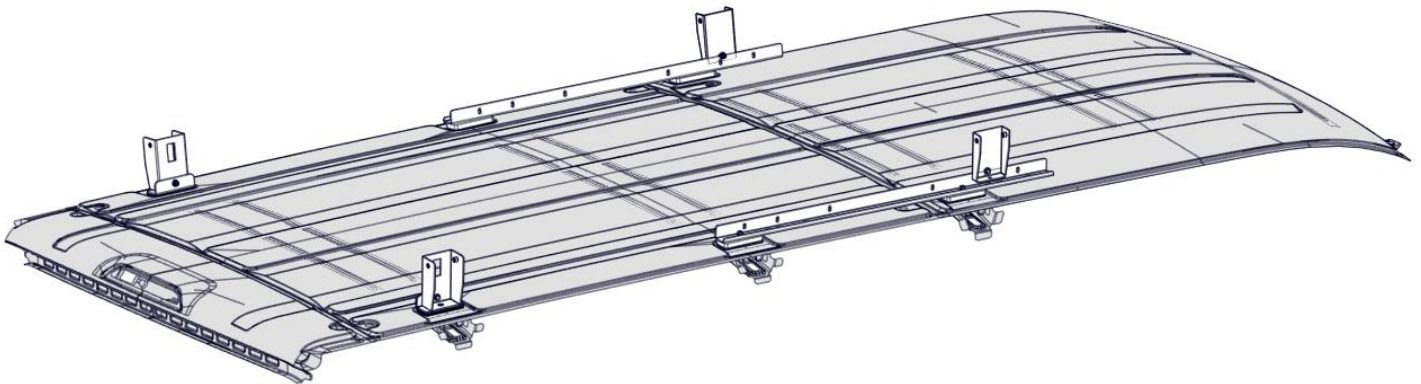

KARGO MASTER[®]

WE PUT EVERYTHING WITHIN REACH.

Instruction Guide

4A99H

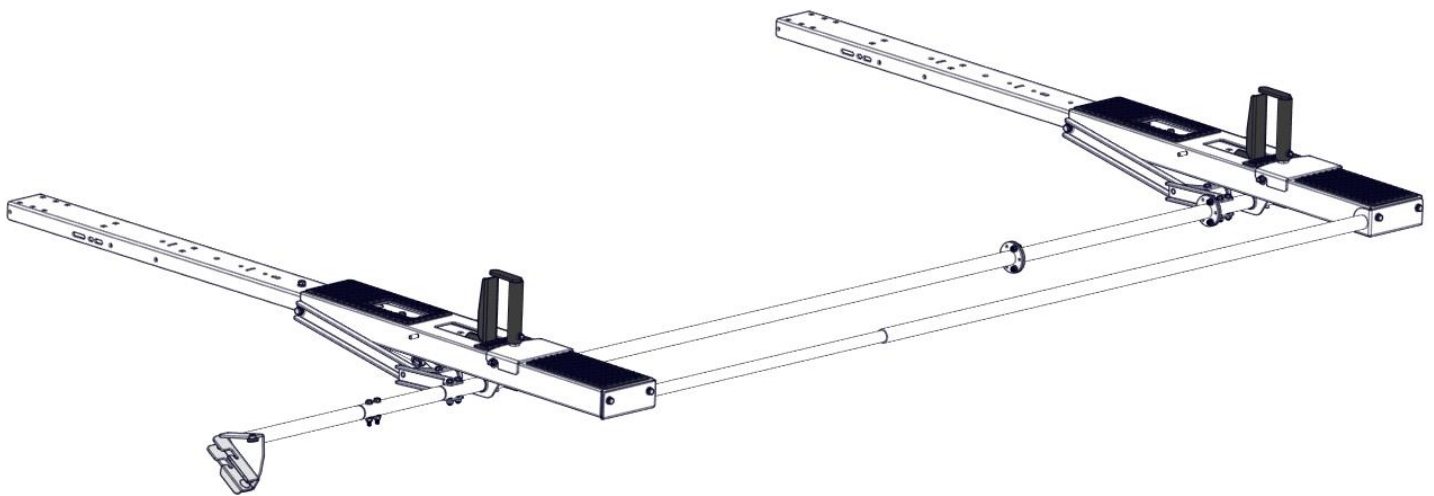

*PLEASE READ ALL INSTRUCTIONS AND WARNINGS PRIOR TO ASSEMBLING,
INSTALLING, AND USING THIS PRODUCT*

Warning



Always check for wires, fuel tanks and lines, brake lines and other important vehicle functionality items prior to drilling and installing all products.

Tools Needed

3/8" Socket and Wrench	Phillips Driver
7/16" Socket and Wrench	1/2" Socket and Wrench



Before You Begin

- Read all instructions.
 - Have vehicle specific mounting installed on vehicle.
 - **DO NOT EXCEED MANUFACTURERS WEIGHT CAPACITY FOR ROOF.**
-

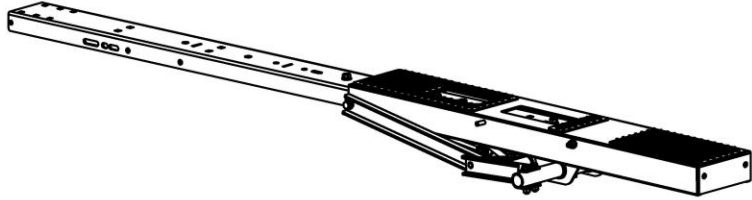
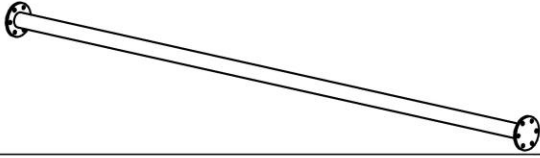
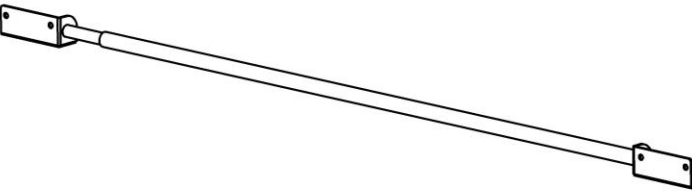
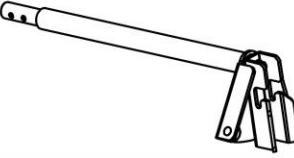
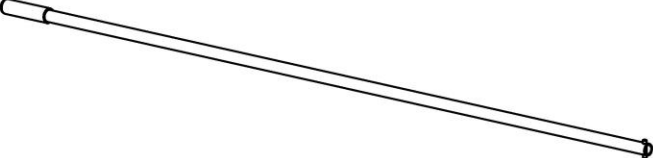
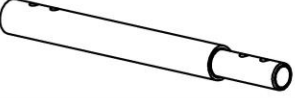
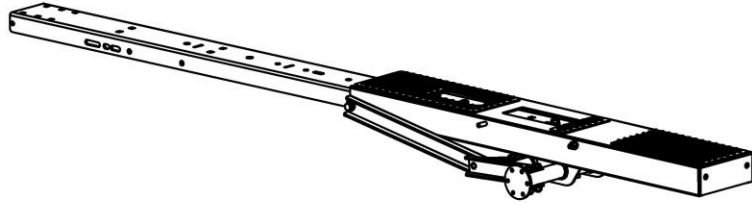
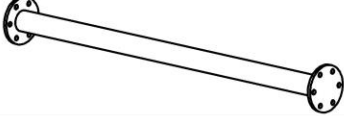



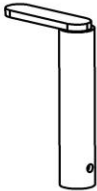
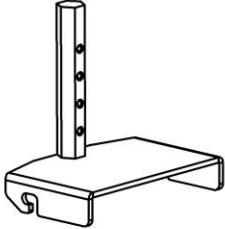

Parts 1 of 2

ITEM NO.		PART NUMBER	DESCRIPTION	QTY.
A		4A99H-Rear-1	Rear Pan Assembly	1
B		40993-24	Torque Tube	1
C		4A93L-7	End Tube Assembly	1
D		40993-43	Actuator	1
E		40993-44	Handle Assembly	1
F		40993-40-002	Acuator Extension	1
G		4A99H-Front-1	Front Pan Assembly	1
H		40993-25	Torque Tube Extension	1

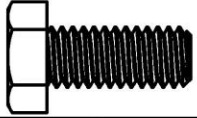
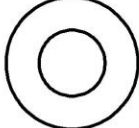
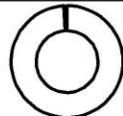
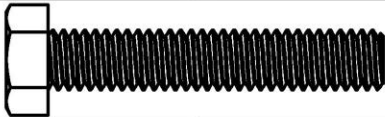
Parts 2 of 2

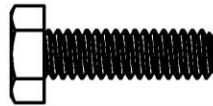
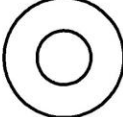
ITEM NO.		PART NUMBER	DESCRIPTION	QTY.
J		4A900-35	Ladder Hook-Top	2
K		4A900-36	Ladder Hook-Base	2
L		4A900-30-004-R3	Ladder Stop	2
		18-4A99H	HARDWARE	1

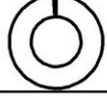
Hardware

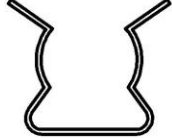
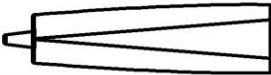
ITEM NO.	TO SCALE	PART NUMBER	DESCRIPTION	QTY.
1		91286A154	5/16"-18 x 3/4" Hex Head	4
2		90126A030	5/16" Flat Washer	8
3		91102A755	5/16" Split Lock Washer	4
4		92865A589	5/16"-18 x 1-3/4" Hex Head	2
5		95615A160	5/16"-18 Nyloc	2
6		92865A541	1/4"-20 x 7/8" Hex Head	11
7		90126A029	1/4" Flat Washer	20
8		95615A120	1/4"-20 Nyloc	9
9		91104A029	1/4" Split Lock Washer	2
10		90272A244	#10-24 x 5/8" Phillips Head	2
11		90631A011	#10-24 Nyloc	2
12		Handle Holder Clip	*not to scale*	2
		BH-821	Sealant	1

Step 1 – Place Front Bow

- Place the front bow on top of the installed feet. Be sure the bow is centered on the vehicle.

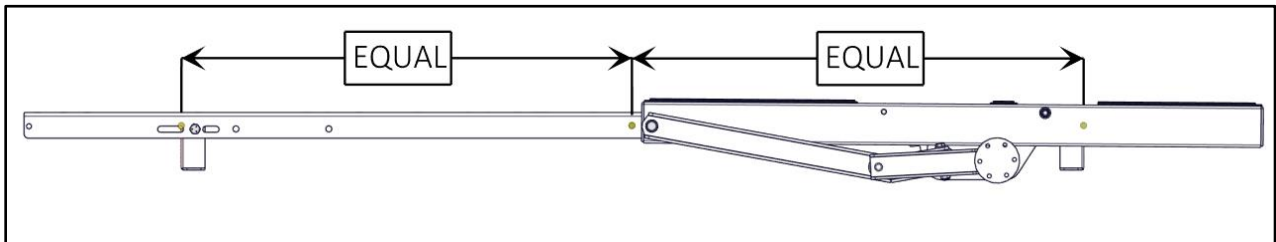
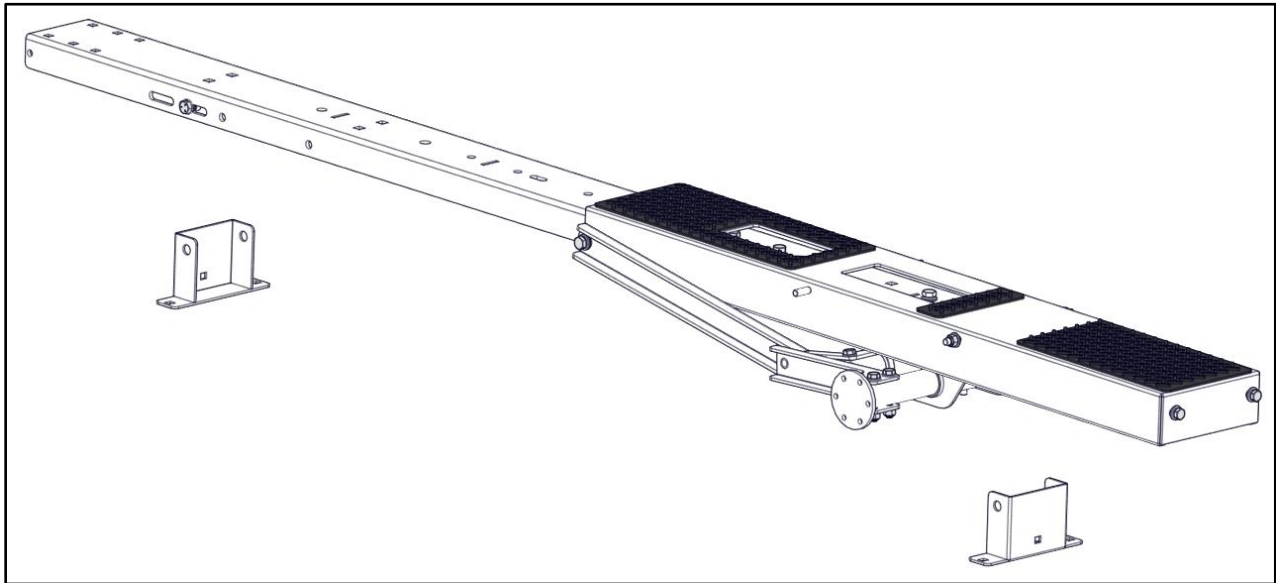

- The same slot, but on opposite sides of the bow will be used to attach the bow to the feet. These slots will vary based on which vehicle the ladder rack is being installed on.

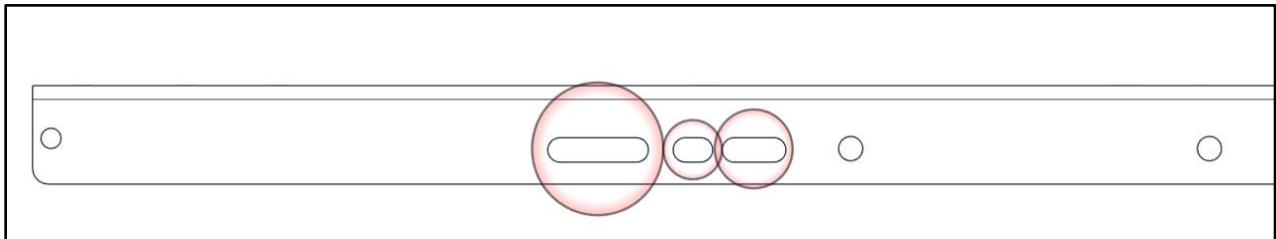

- Bolt the front bow to the feet using 3/8" x 3/4" hex head bolts, 3/8" lock washers and 3/8" flat washers that are included in the vehicle mounting kit. The ladder pan will need to be pivoted out of the way to access the mount locations on the passenger side.
- Snug tighten, but allow movement.

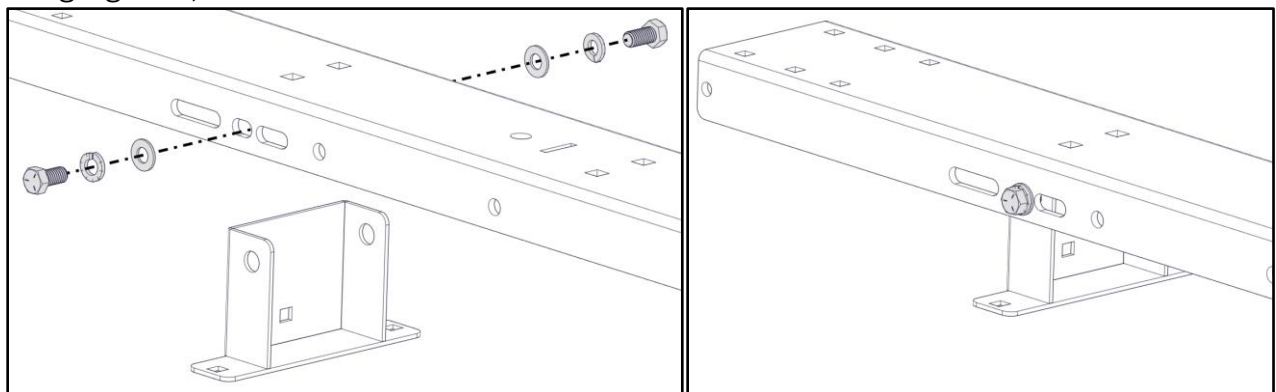

Step 2 – Place Rear Bow

- Place the rear bow on top of the installed feet. Be sure the bow is centered on the vehicle.

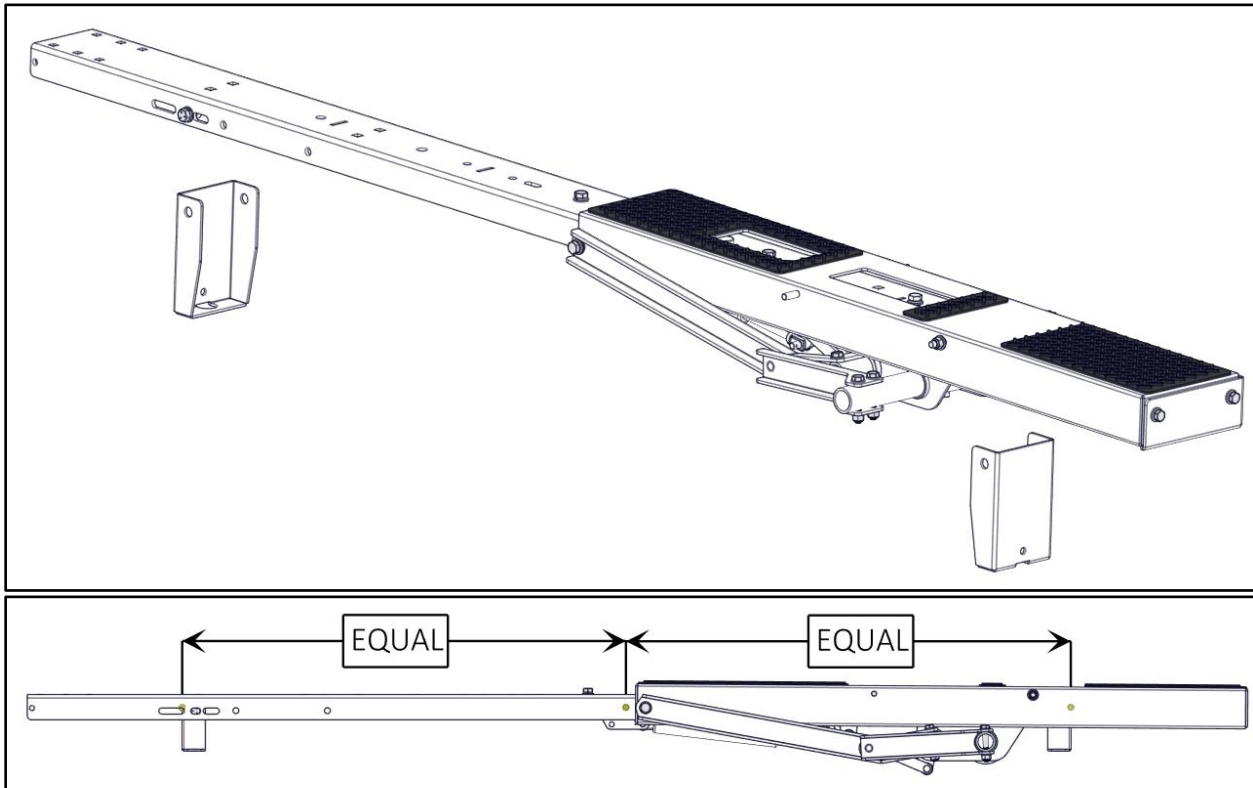

- The same slot, but on opposite sides of the bow will be used to attach the bow to the feet. These slots will vary based on which vehicle the ladder rack is being installed on.
- Bolt the rear bow to the feet using 3/8" x 3/4" hex head bolts, 3/8" lock washers and 3/8" flat washers that are included in the vehicle mounting kit. The ladder pan will need to be pivoted out of the way to access the mount locations on the passenger side.
- Snug tighten, but allow movement.

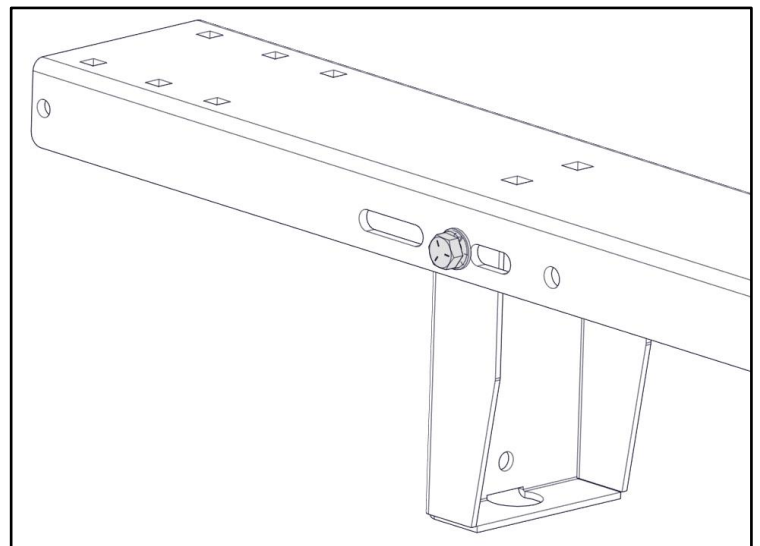
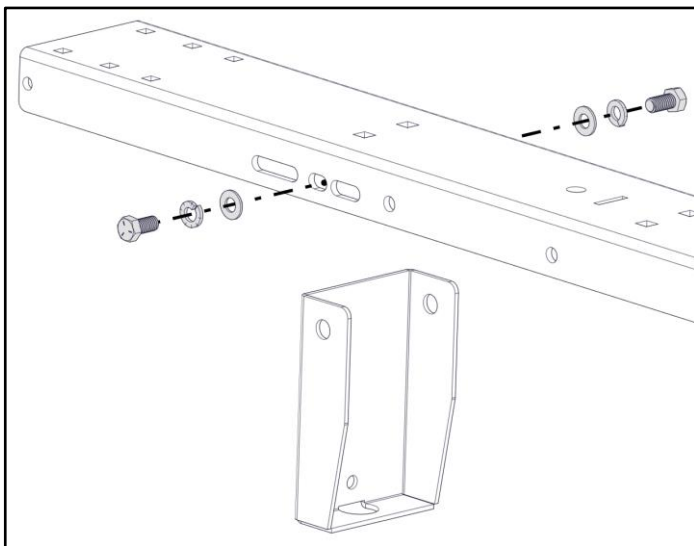

Step 3 – Install Torque Tube

- Measure the minimum distance between the front and rear bow as shown below.

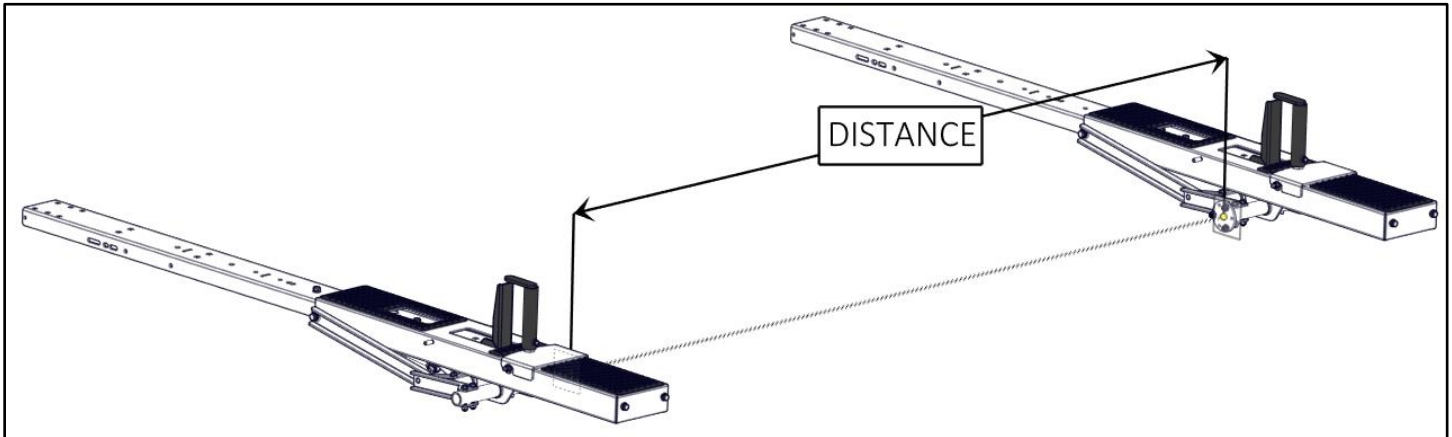

- If the distance is approximately 57", only the long torque tube will be needed. If the distance is approximately 82", the torque tube and the extension will be needed.

Note: The extension is being used in the picture below.

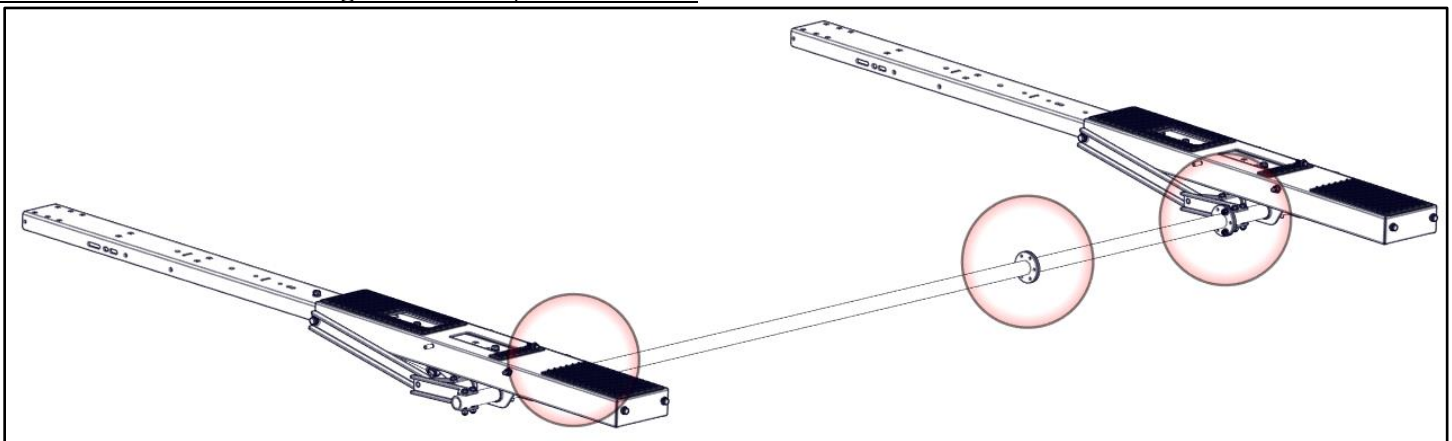

- Bolt the torque tube to the front and rear bow using 1/4" x 7/8" hex head bolts, 1/4" flat washers and 1/4" nyloc nuts. Repeat this process if the extension is being used.
- Snug tighten, but allow movement.

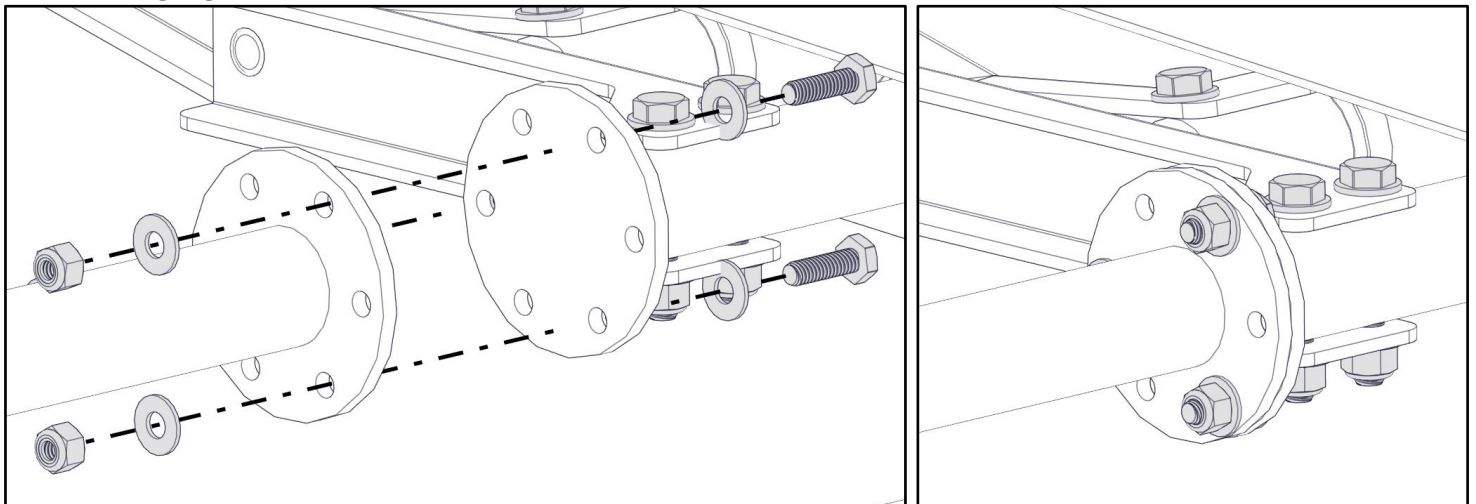

Step 4 – Install End Tube

- Bolt the end tube to the end of the pan on the front and rear bow using 5/16" x 3/4" hex head bolts, 5/16" lock washers and 5/16" flat washers.
- Snug Tighten, but allow movement.

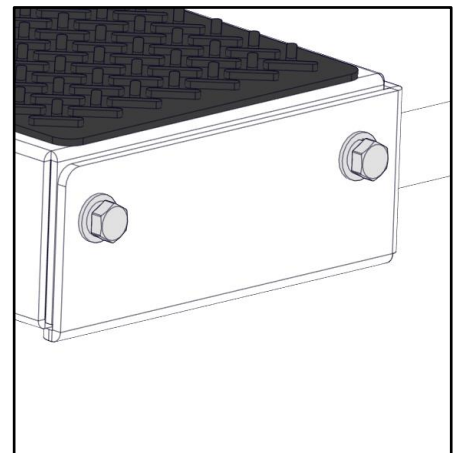
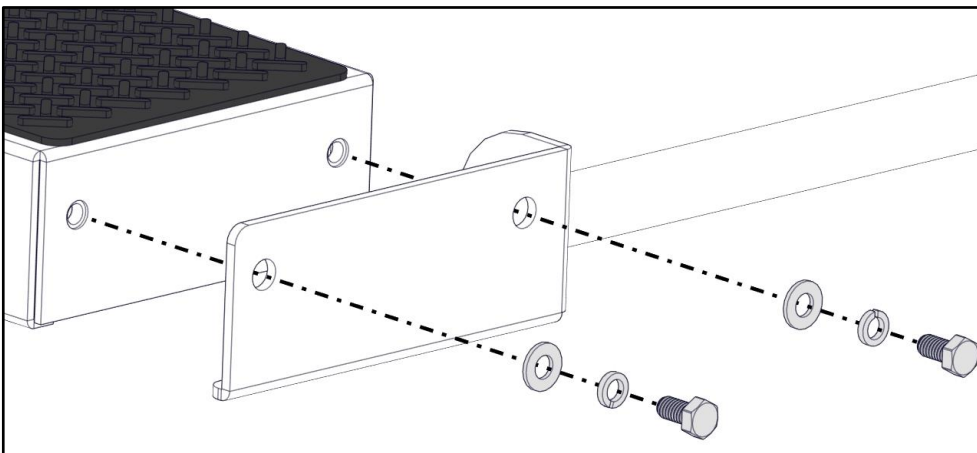
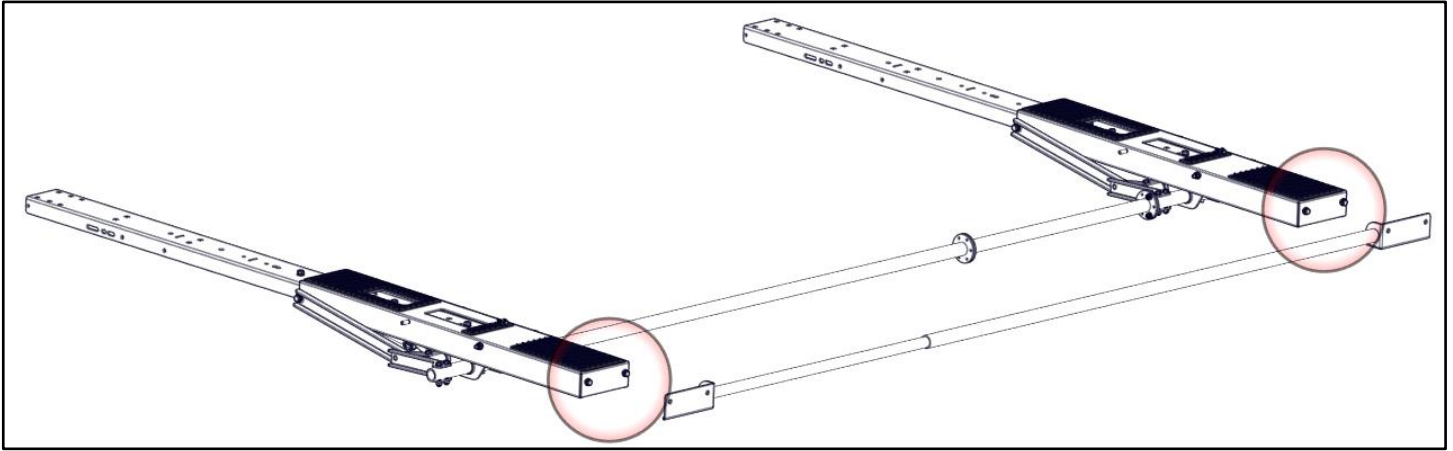

Step 5 – Install Actuator

- Remove the hardware, as shown, from the tube on the rear bow.
- Insert actuator extension into the tube and attach using the previously removed hardware.

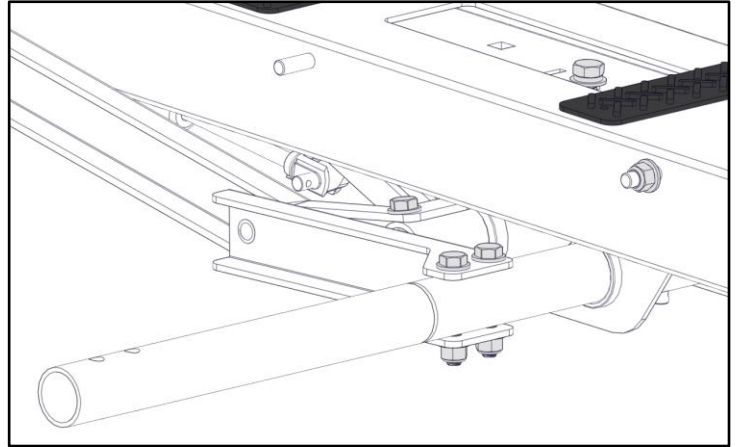
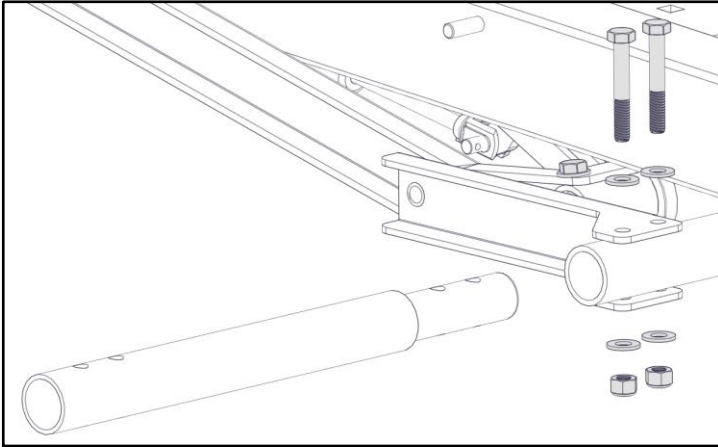

- Insert actuator assembly into the end of the actuator extension as shown below.
- Bolt into place using two 5/16" x 1-3/4" hex head bolts, four 5/16" flat washers and two 5/16" nyloc nuts.
- Tighten.

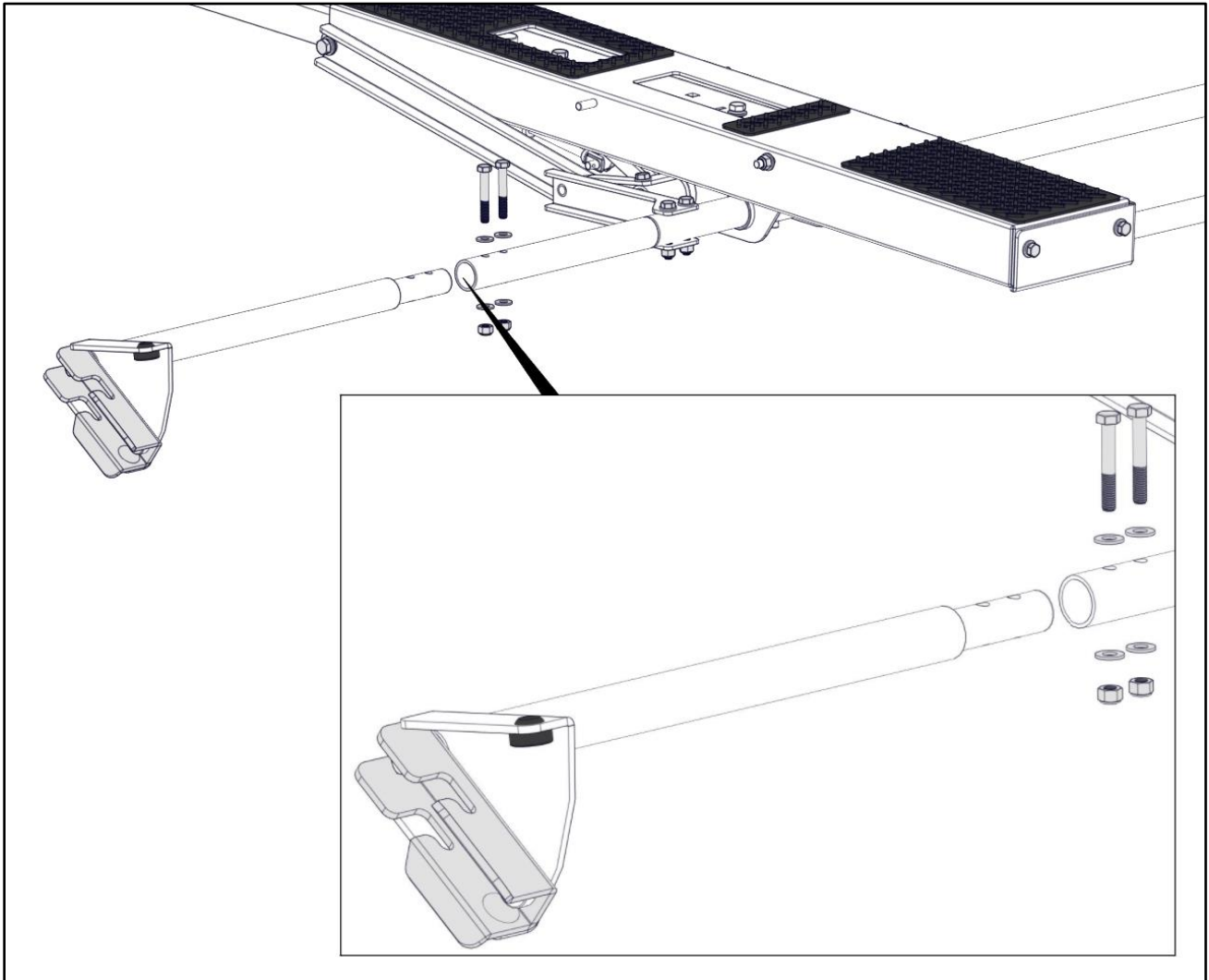

Step 6 – Install Ladder Hook

- Assemble the ladder hooks.

Note: This can be adjusted at a later time to better fit the size of the ladder being used.

- Bolt into place using 1/4" x 7/8" hex head bolt, 1/4" lock washer and a 1/4" flat washer.
- Repeat for a second ladder hook.
- Tighten.

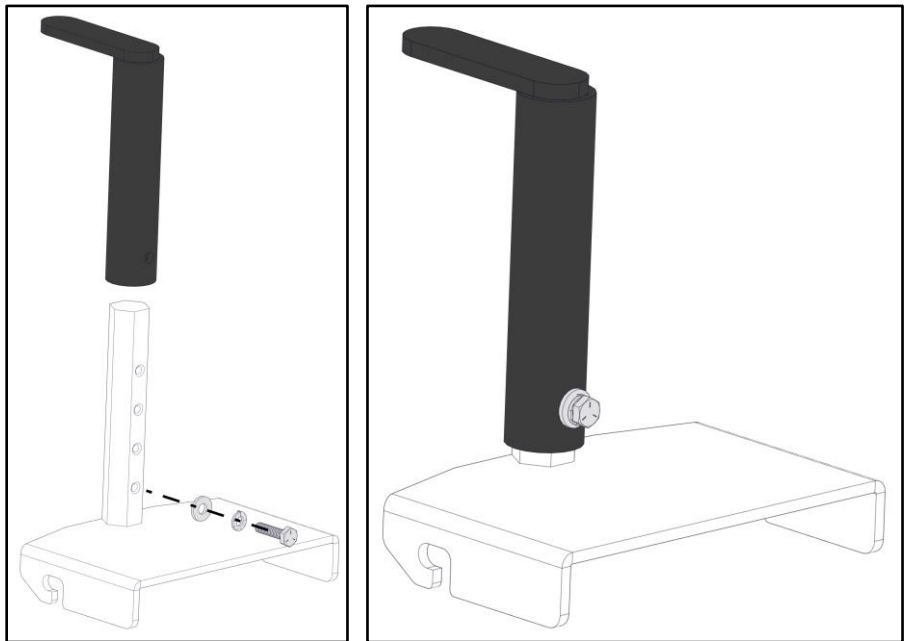

- Place one ladder hook assembly onto the front bow and one ladder hook on the rear bow in the desired locations. Use the threaded studs to locate the ladder hook location.

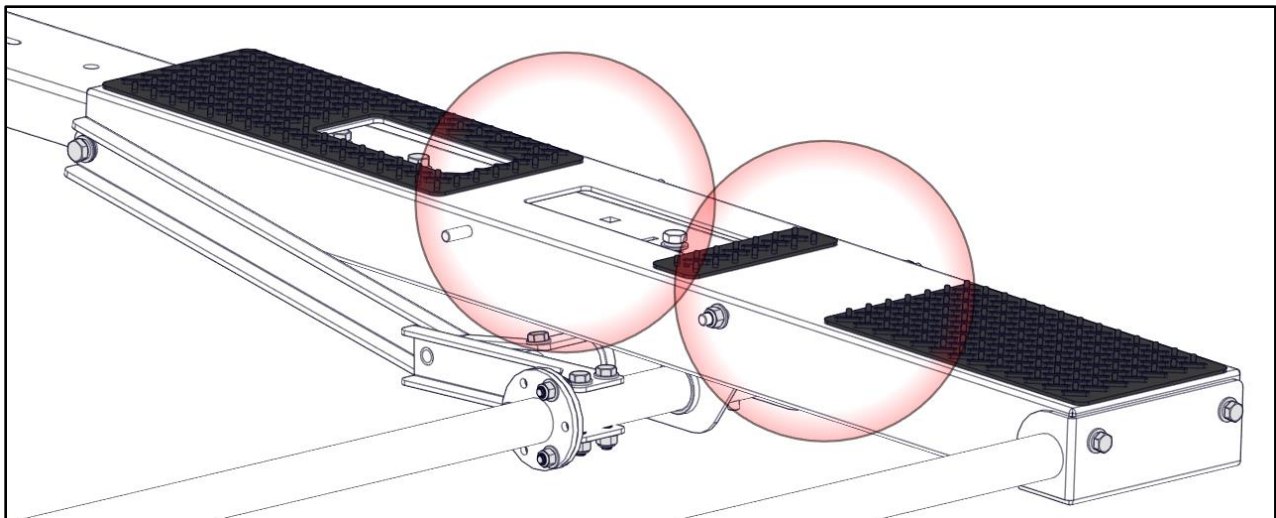

- Bolt into place using two 5/16" flat washers and two 5/16" nyloc nuts at each location.

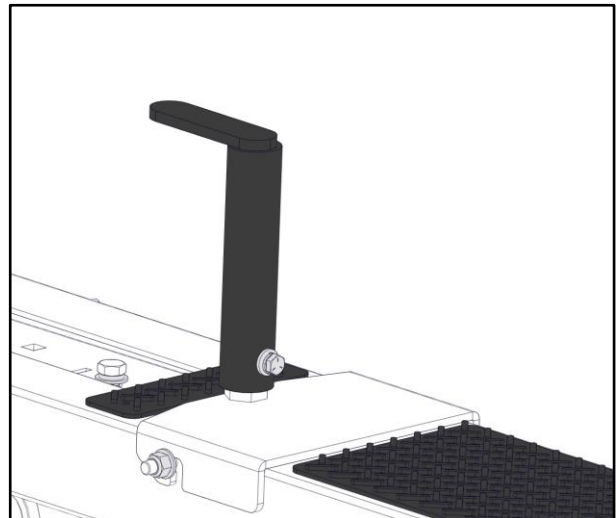
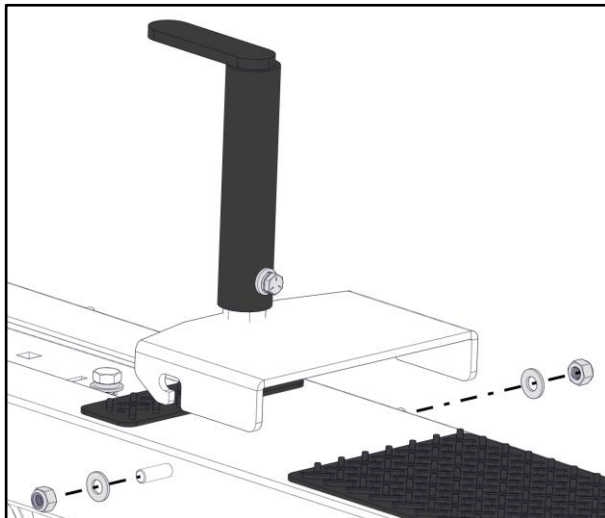

Step 7 – Install Ladder Stop

- Find the slot and the installed hardware near the previously installed ladder hook assembly.
- Remove the hardware in the bow and place the ladder stop in that location. Bolt into place using the removed hardware. Be sure the tab on the ladder stop aligns with the slot in the bow.
- Repeat on each bow.
- Tighten.

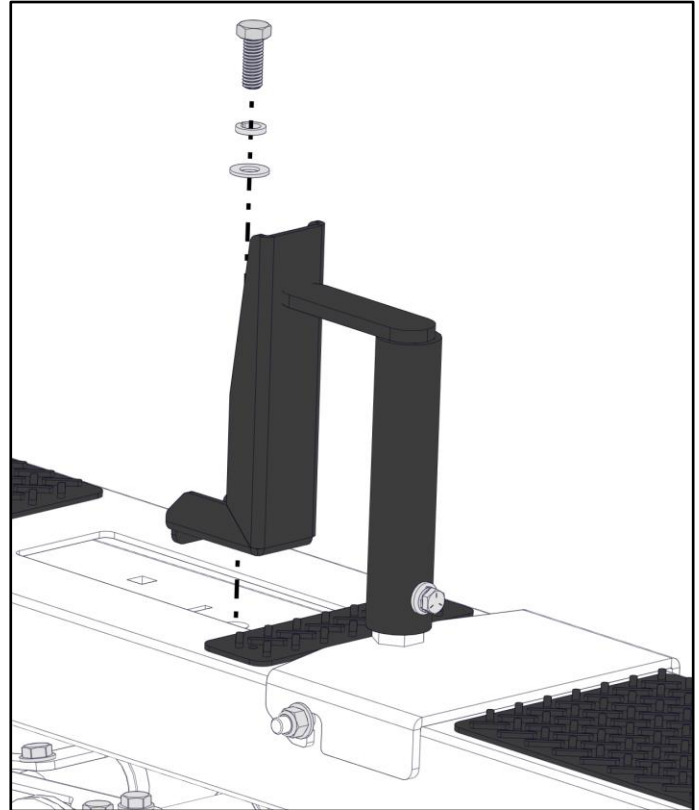
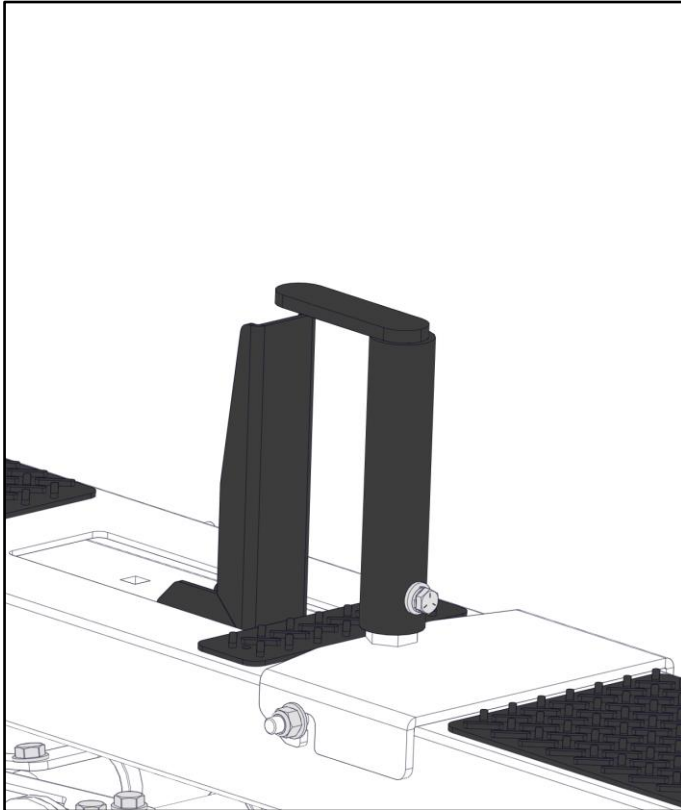

Step 8 – Install Handle Bar Holder

- Determine the best location for the installation of the handle bar. Most installs are at the rear of the van, on the backside of a shelving unit. This makes it easily accessible when the rear doors are open.
- Drill a 1/4" hole in desired locations.
- Install clips using #10 hardware provided.

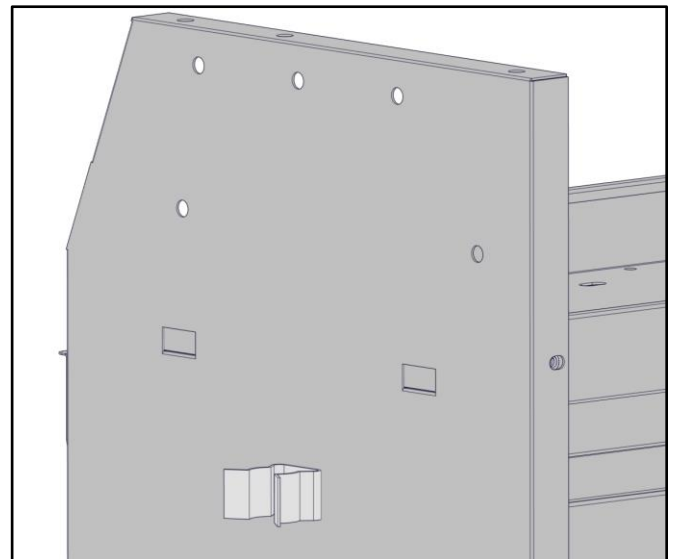
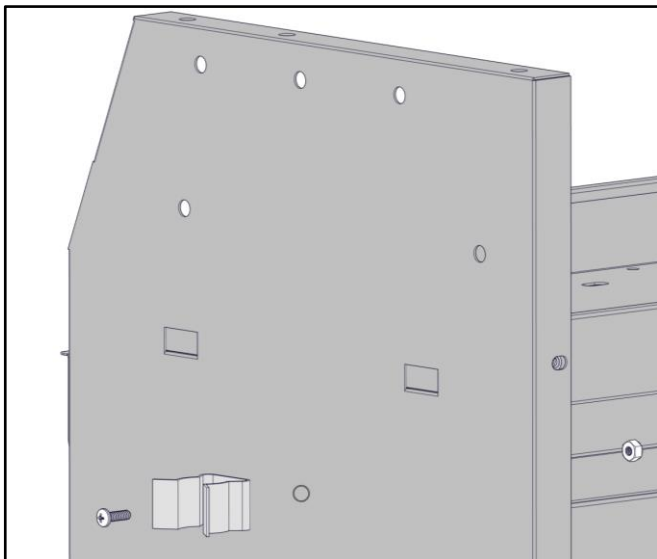
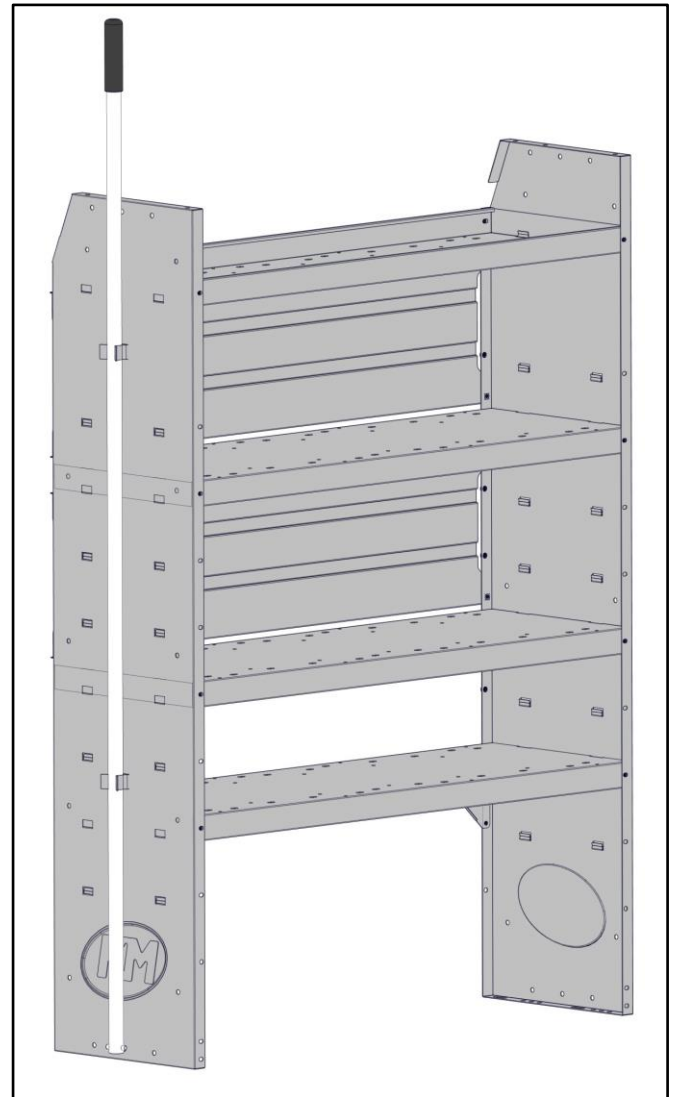
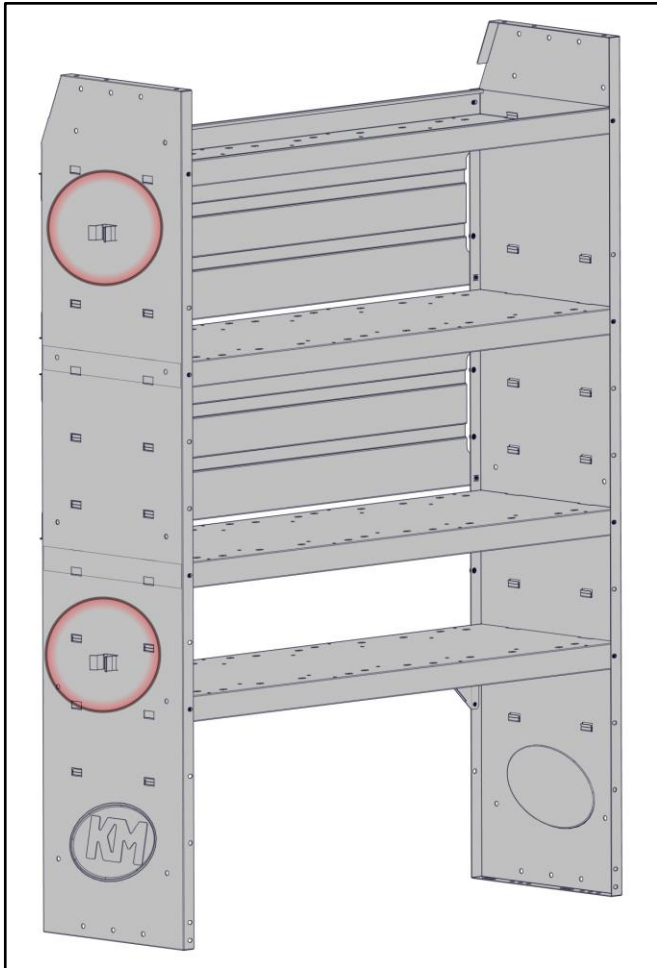

Step 9 – Test Ladder Rack

- Go back and ensure all hardware is tight. Tighten the torque tube first.
- Prior to installing a ladder, place the long handle into the handle bar assembly and test that the ladder rack mechanism works correctly.

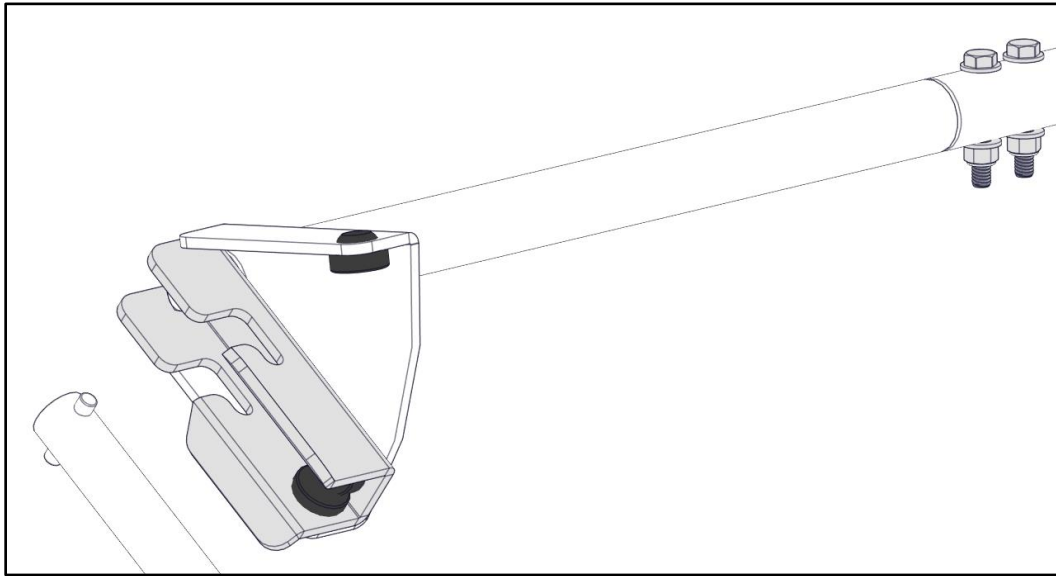

ENSURE ALL HARDWARE IS TIGHT
YOUR INSTALLATION IS NOW COMPLETE

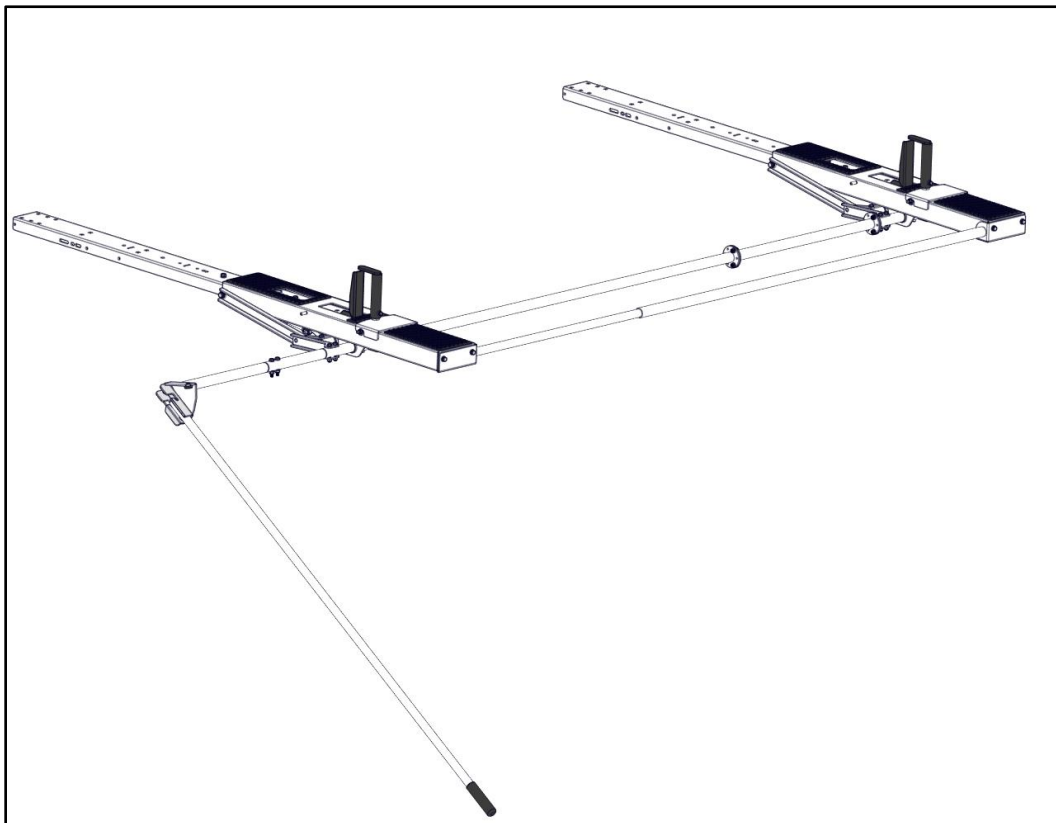

KARGO MASTER®

WE PUT EVERYTHING WITHIN REACH.

Instruction Guide

4A91H

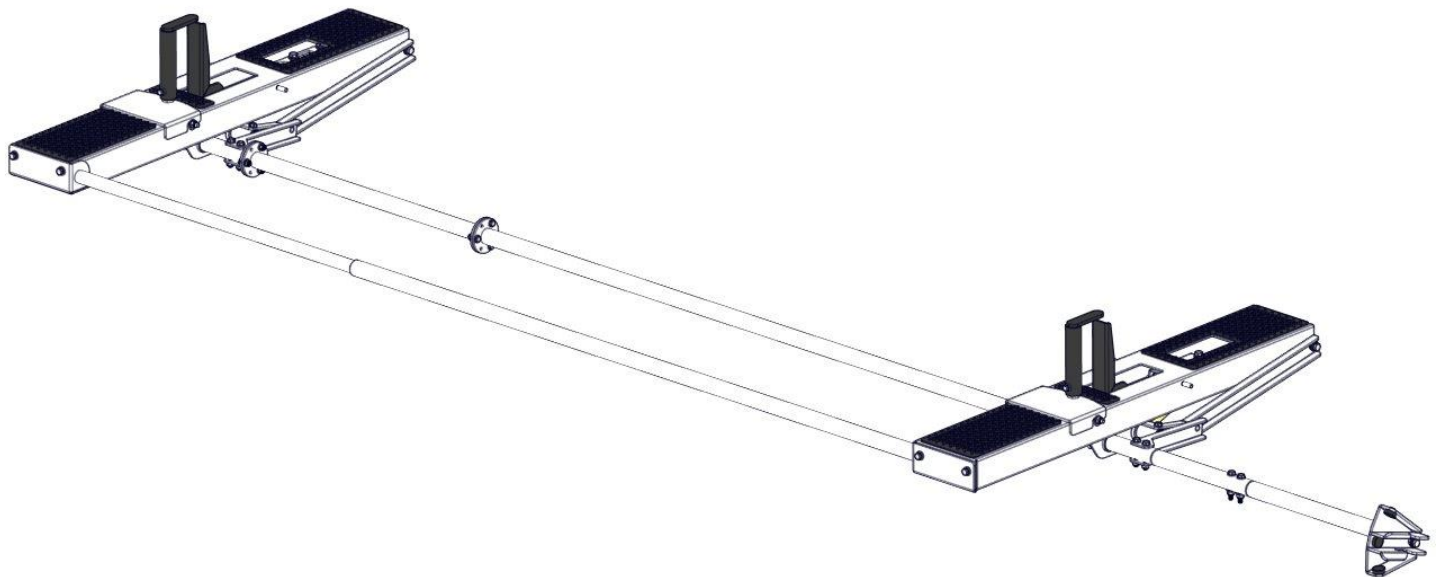

*PLEASE READ ALL INSTRUCTIONS AND WARNINGS PRIOR TO ASSEMBLING,
INSTALLING, AND USING THIS PRODUCT*

Warning



Always check for wires, fuel tanks and lines, brake lines and other important vehicle functionality items prior to drilling and installing all products.

Tools Needed

3/8" Socket and Wrench	1/2" Socket and Wrench
7/16" Socket and Wrench	



Before You Begin

- Read all instructions.
 - This kit is a driver side add on. A ladder rack must be assembled prior to installation of this kit.
 - **DO NOT EXCEED MANUFACTURERS WEIGHT CAPACITY FOR ROOF.**
-

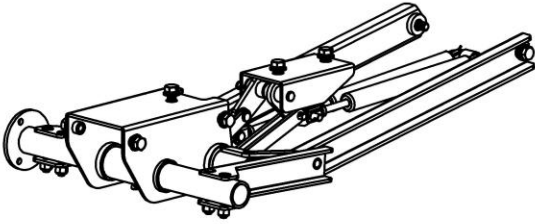
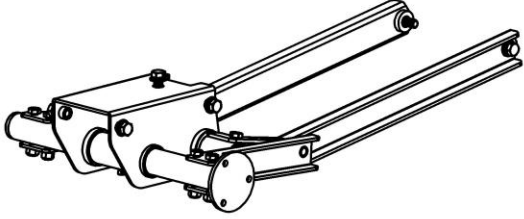
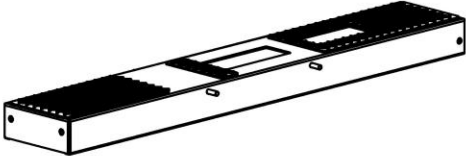
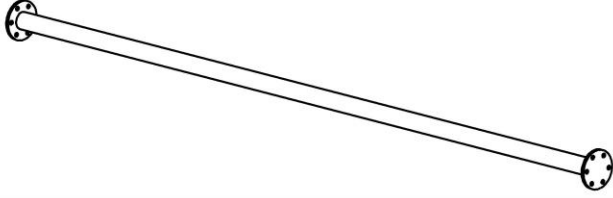
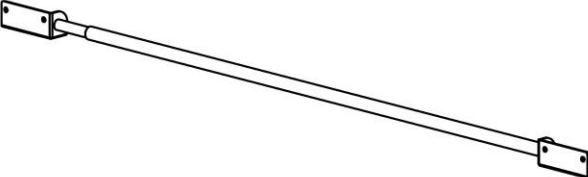
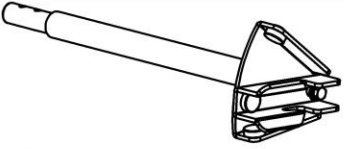
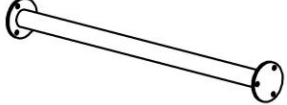



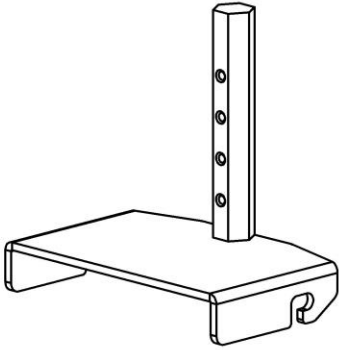
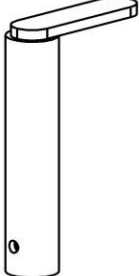
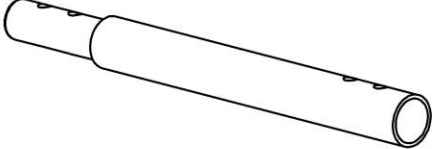
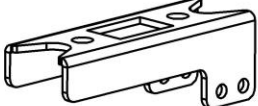

Parts 1 of 2

ITEM NO.		PART NUMBER	DESCRIPTION	QTY.
J		4A99H-08	Rear Bow Mechanism Assembly	1
K		4A99H-09	Front Bow Mechanism Assembly	1
C		4A99H-30	Pan Assembly	2
D		40993-24	Torque Tube	1
E		4A93L-7	End Tube Assembly	1
F		40993-45	Actuator Assembly	1
G		40993-25	Torque Tube Extension	1

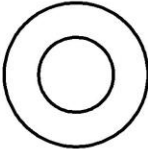
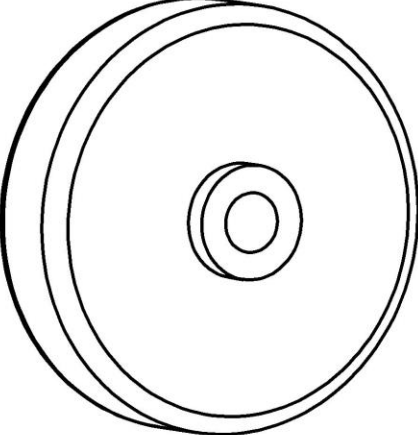

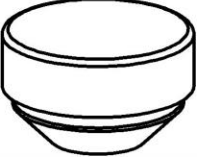
Parts 2 of 2

ITEM NO.		PART NUMBER	DESCRIPTION	QTY.
H		4A900-36	Ladder Hook Base	2
J		4A900-35	Ladder Hook	2
K		40993-40-002	Actuator Extension	1
L		4A900-50-001-R3-2	Spring Mount Assembly	1
M		4A900-30-004-R3	Ladder Stop	2
N			Spring	1
		18-4A91H	Hardware	1

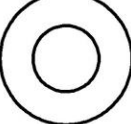
Hardware (1 of 2)

ITEM NO.	TO SCALE	PART NUMBER	DESCRIPTION	QTY.
1		40900-10-006	Axle (Scale 1:2)	2
2		90295A170	Nylon Washer	4
3		9960t26-Wheel	2-1/4" Wheel	4
4		9960T26-Cap	Wheel Cap	4
5		9309k19	Rubber Bumper	2
6		92620A581	5/16"-18 x 3/4" Hex Bolt	4
7		91102A030	5/16" Lock Washer	4
8		91247A591	5/16"-18 x 1-3/4" Hex Bolt	2
9		95615A160	5/16"-18 Nyloc	2
10		90126A030	5/16" Flat Washer	8

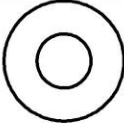
Hardware (2 of 2)

ITEM NO.	TO SCALE	PART NUMBER	DESCRIPTION	QTY.
11		92865A541	1/4"-20 x 7/8" Hex Bolt	11
12		90126A029	1/4" Flat Washer	20
13		97135A210	1/4" Nyloc	9
14		91104A029	1/4" Split Lock Washer	2

Step 1 – Assemble Front Bow

- Attach the spring mount to the underside of the front bow using the pre-assembled hardware in the location and orientation shown. (picture shown without mounting feet for clarity)

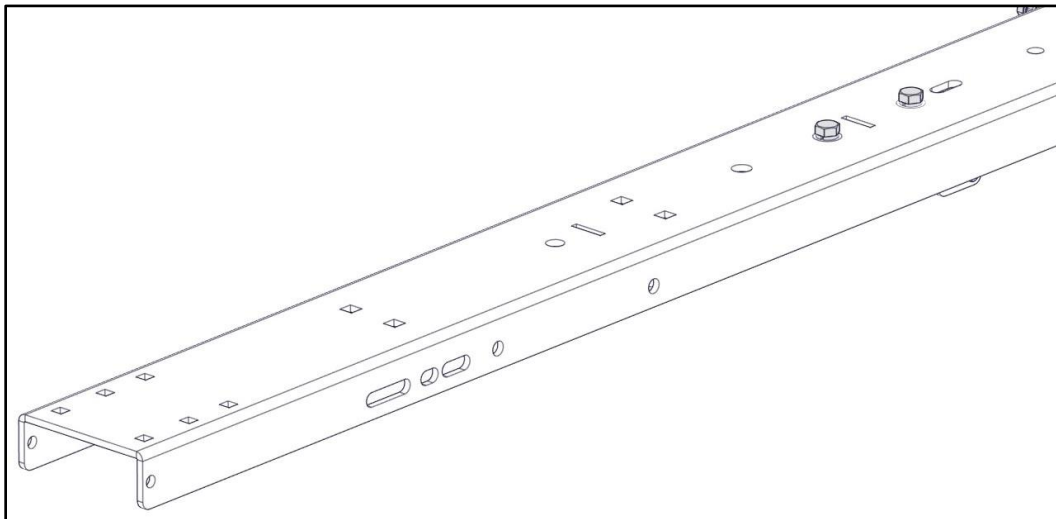
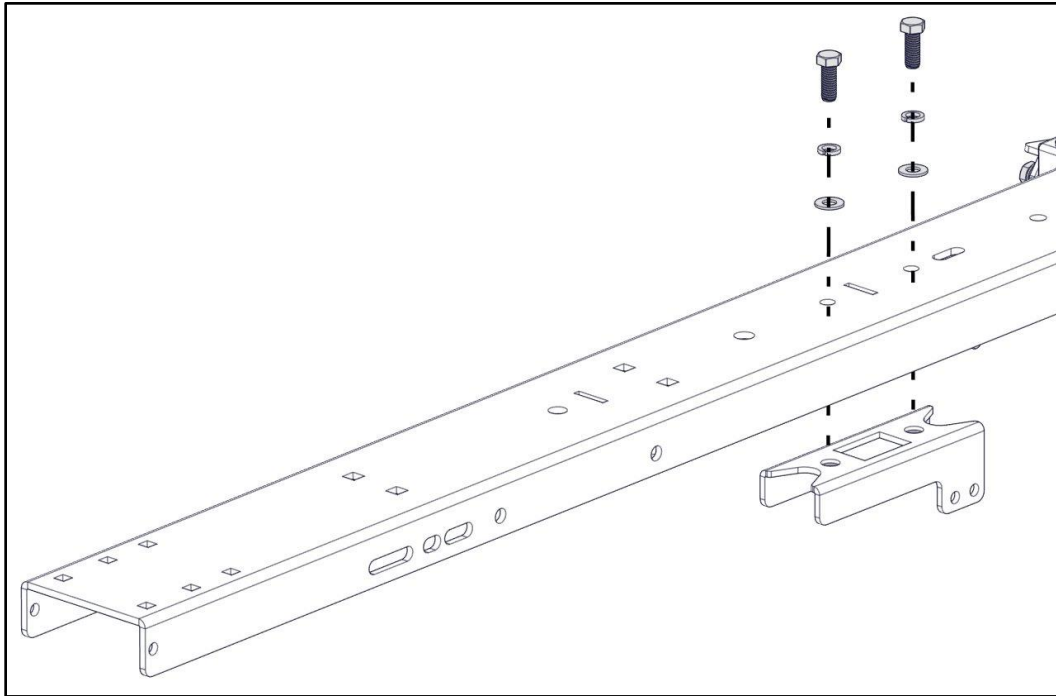

- Remove the 3/8" hardware from the front bow mechanism as shown.

Note: This is the mechanism with NO gas springs.

- Attach the front bow mechanism to the underside of the front bow using the previously removed 3/8" hardware in the locations shown.
- TIGHTEN.

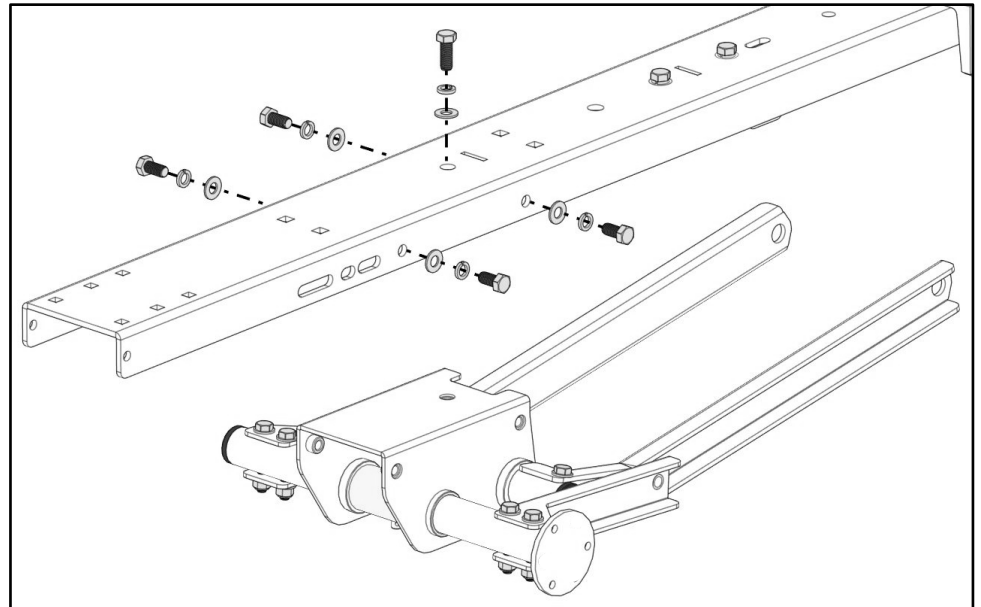

- Insert a rubber bumper in the round hole as shown. The large end of the bumper goes on top of the bow.

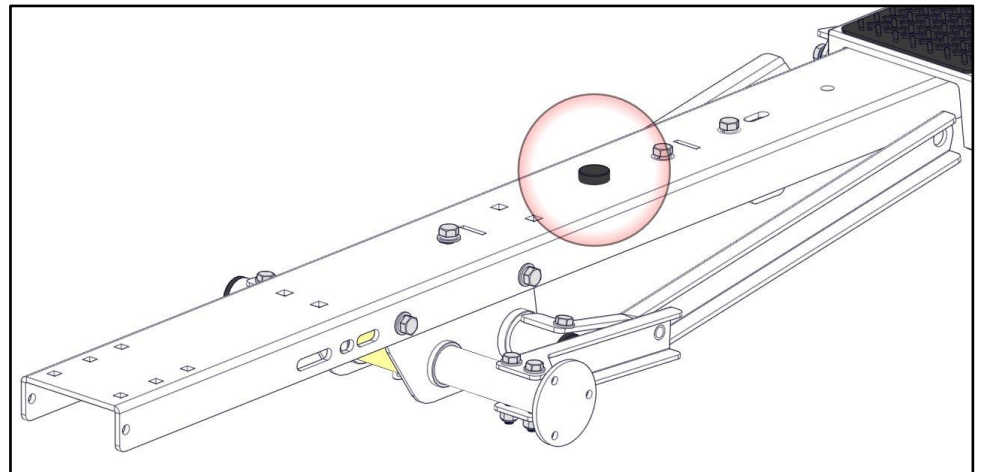

- Slide a wheel axle into the hole at the end of each bow.
- Place a nylon washer at each end of the axle on the outside of the bow.
- Install a wheel at each end of the axle. Cap each wheel with a wheel cap.

WHEN INSTALLING THE PAN, BE SURE THE WHEEL CAPS STAY IN PLACE

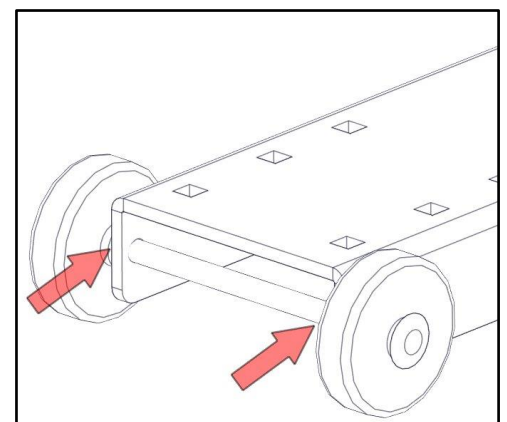
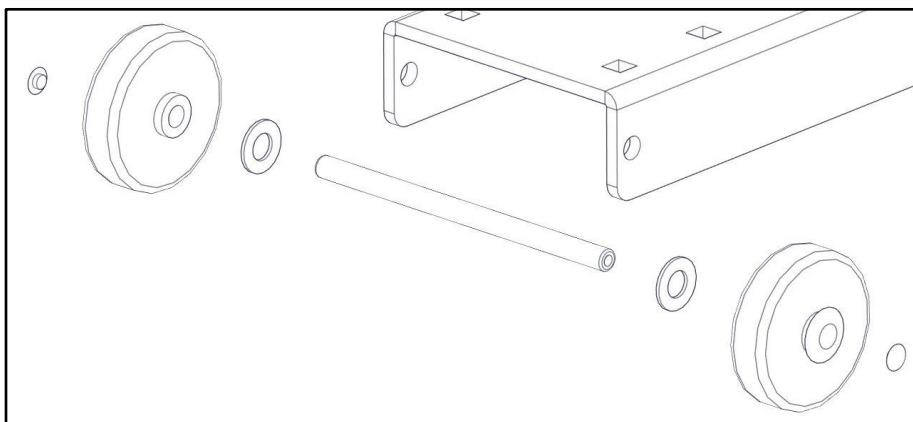

- Rotate the pan perpendicular to the top bow and at a slight angle as shown.
- Maneuver the pan around the wheels.
- Ensure the wheels are contained inside the pan and lay the pan on top of the bow.

****BE SURE THE WHEEL CAPS DID NOT COME OFF****

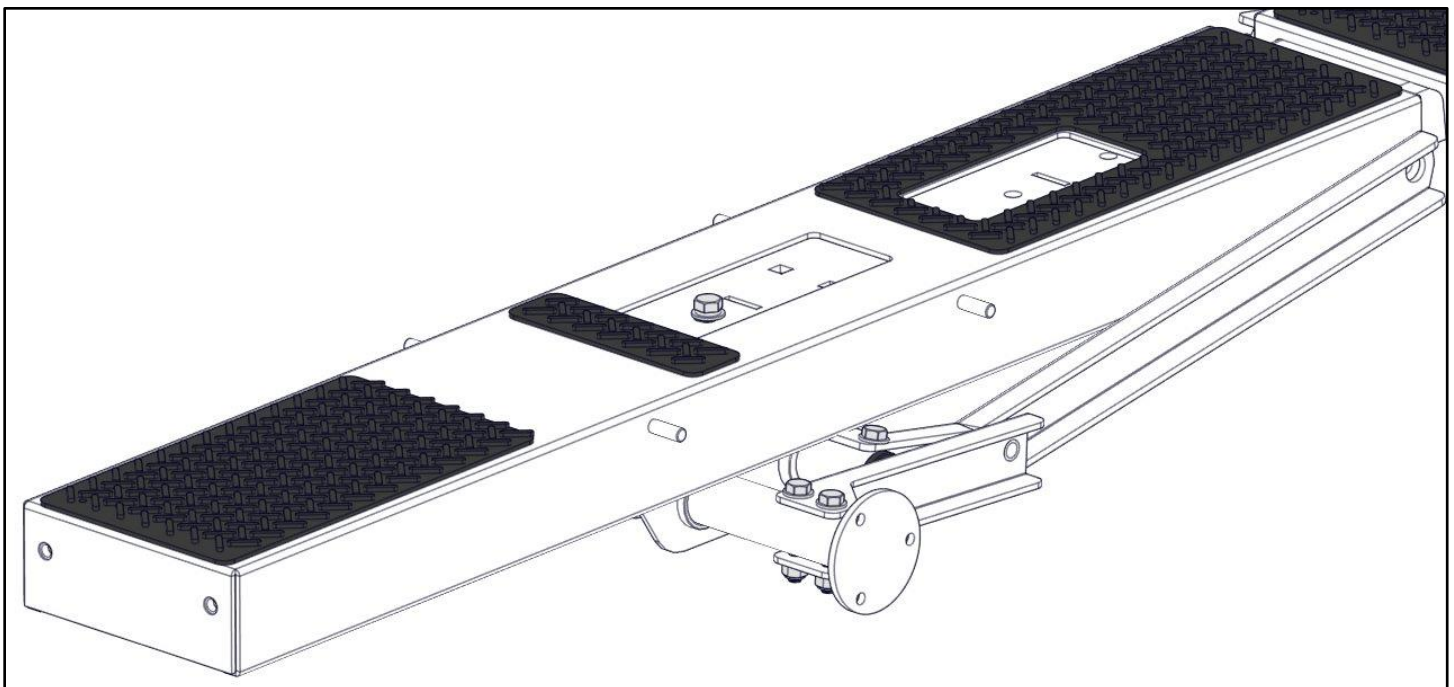
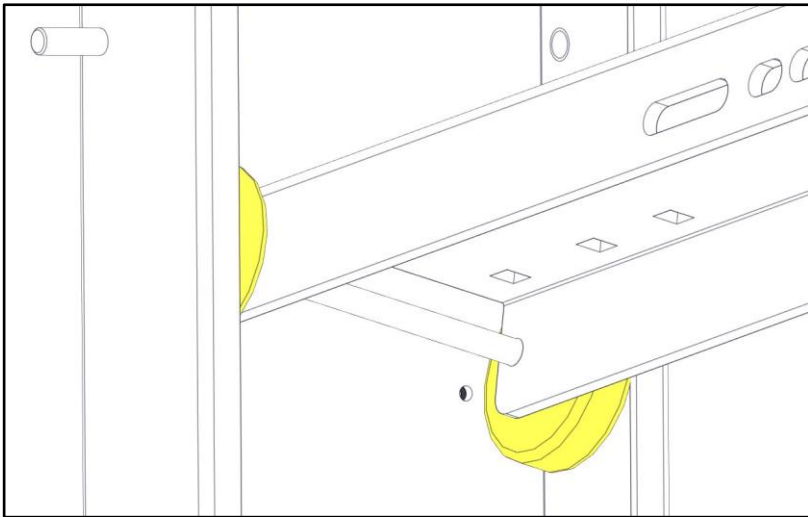
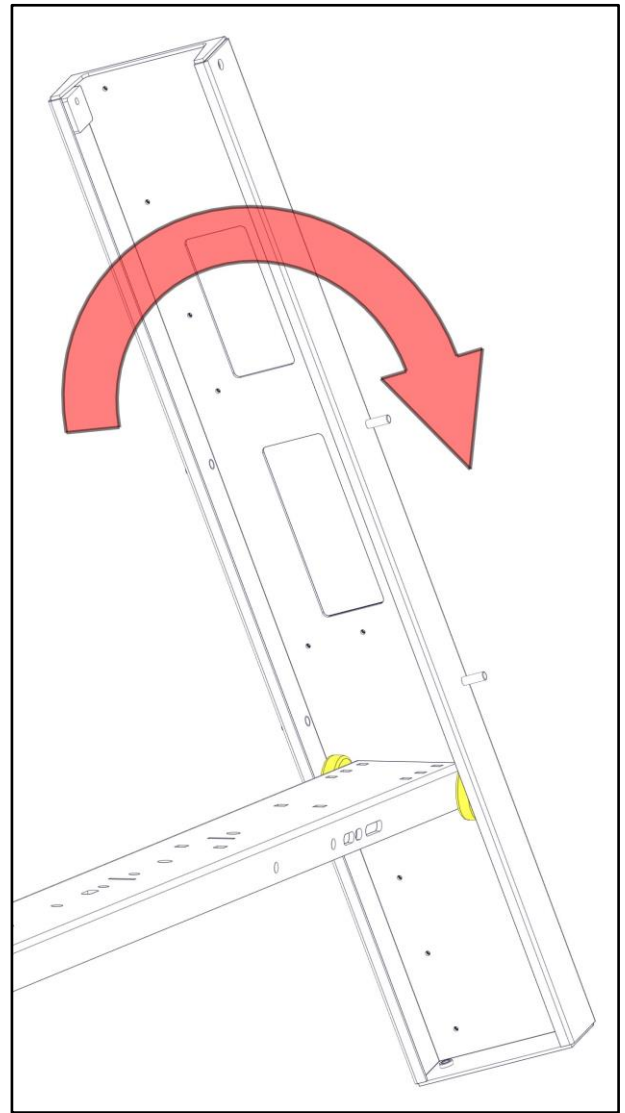

- Remove the hardware that is pre-assembled in the pan assembly (pictures shown without the bow for clarity).

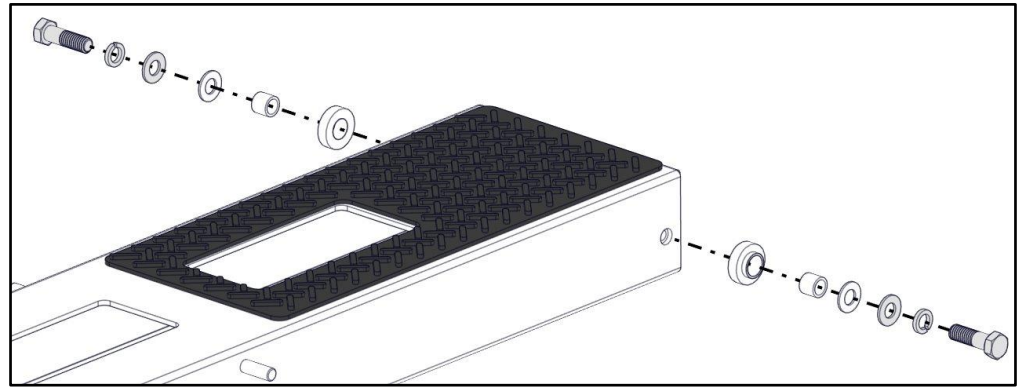

- Place the nylon spacer in between the pan and the arm on both sides.
- The nylon washer goes against the outside of each arm.
- Align the arms from the mechanism assembly with the holes in the pan. Reinstall the previously removed hardware in the orientation shown.
- Do not over tighten. The pan and the arm are designed to rotate against each other.

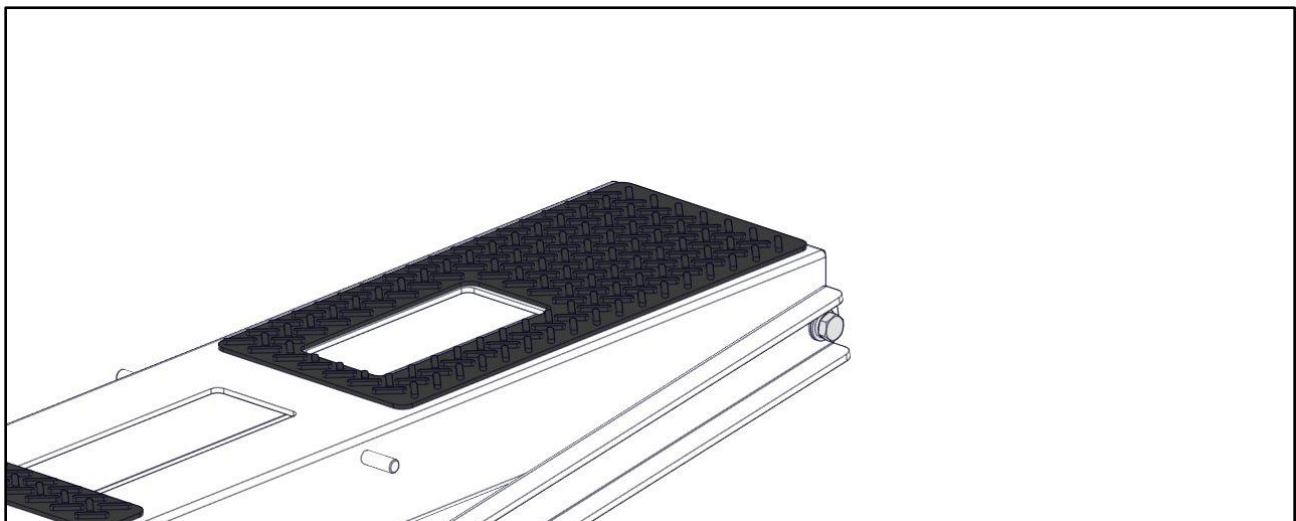
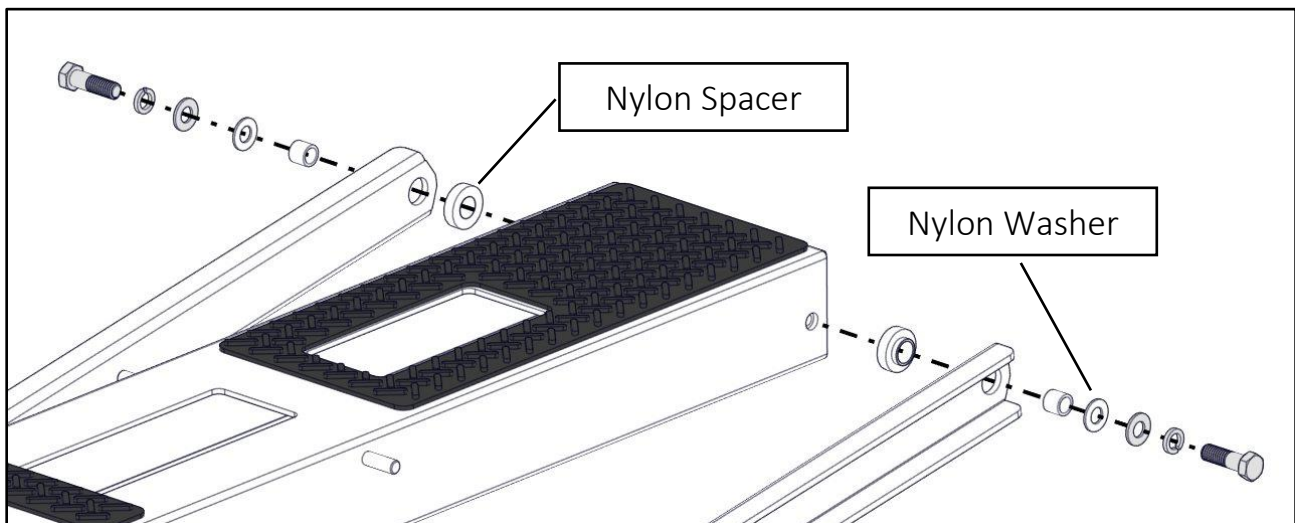

Step 2 – Install Spring on Front Bow

- Install the spring on the underside of the front bow by attaching one end of the spring to the spring mount and the other end of the spring to the front bow mechanism.
- Hook the spring onto the pin in the spring mount bracket (shown without the bow for clarity).

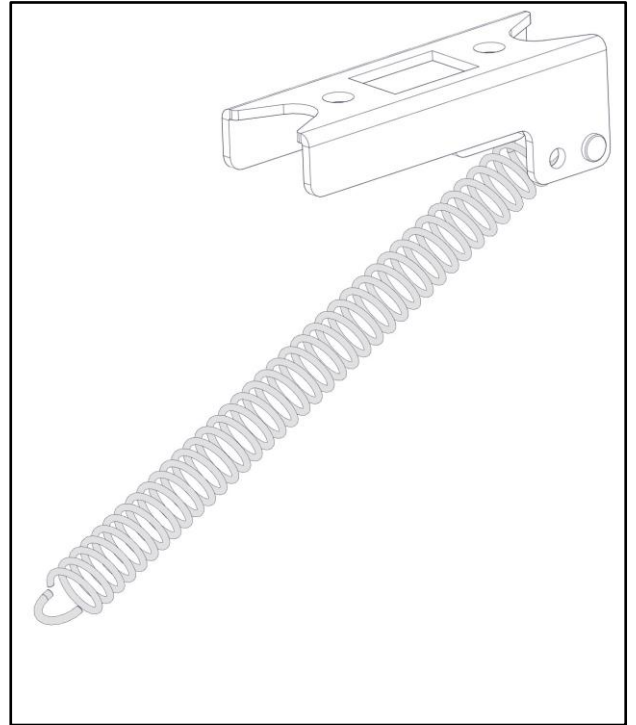
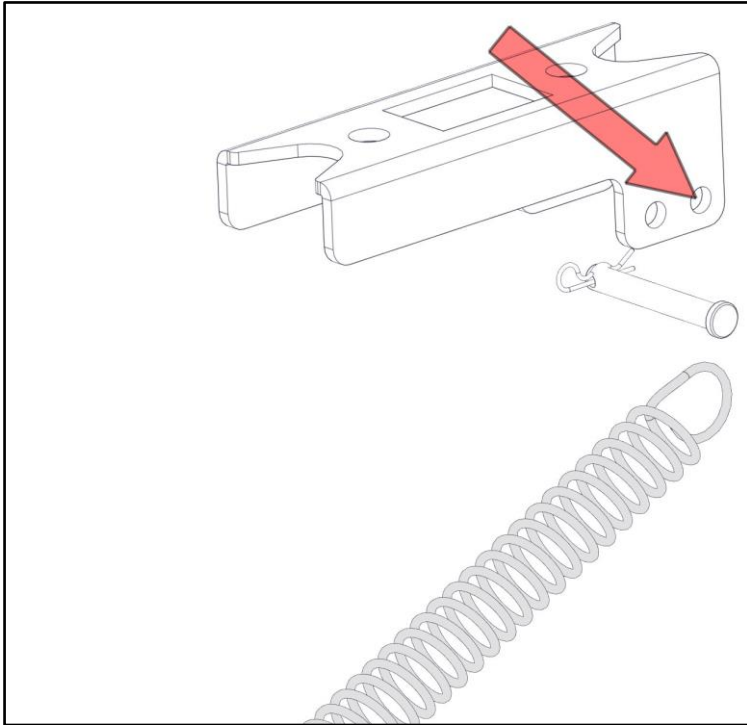

- Pivot the pan to adjust the mount on the mechanism.
- Stretch the spring and hook onto the mount on the front pan mechanism. Return the pan in the down position.

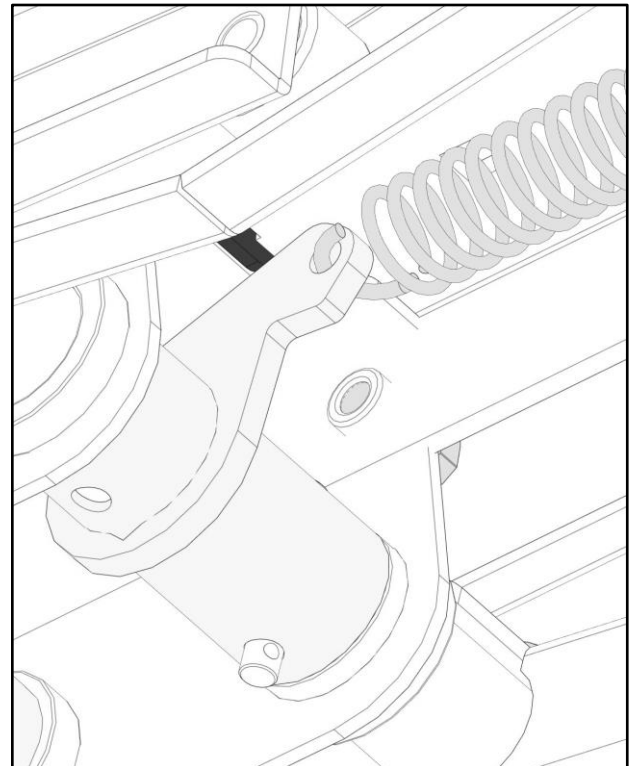

Step 3 – Assemble Rear Bow

- Remove the 3/8" hardware in the rear bow mechanism as shown.

Note: This is the mechanism with the gas springs.

- Attach the rear bow mechanism to the underside of the rear bow using the previously removed 3/8" hardware in the locations shown.

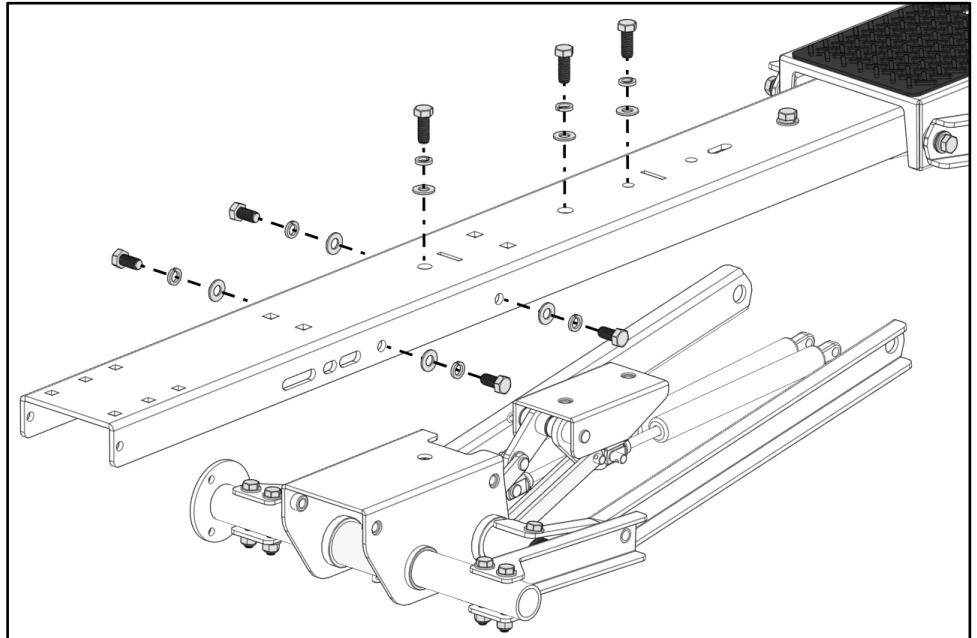

- TIGHTEN.

- Insert a rubber bumper in the slot as shown. The large bumper goes on top of the bow.

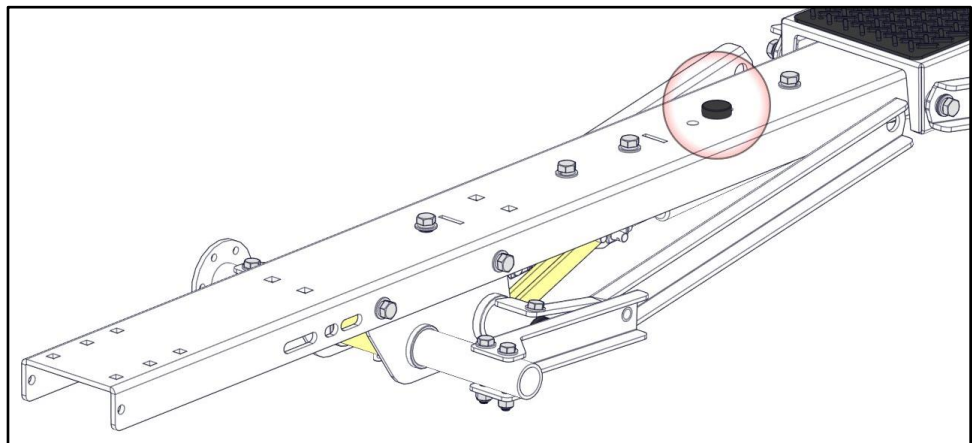

- Slide a wheel axle into the hole at the end of each bow.
- Place a nylon washer at each end of the axle on the outside of the bow.
- Install a wheel at each end of the axle. Cap each wheel with a wheel cap.

****WHEN INSTALLING THE PAN, BE SURE THE WHEEL CAPS STAY IN PLACE****

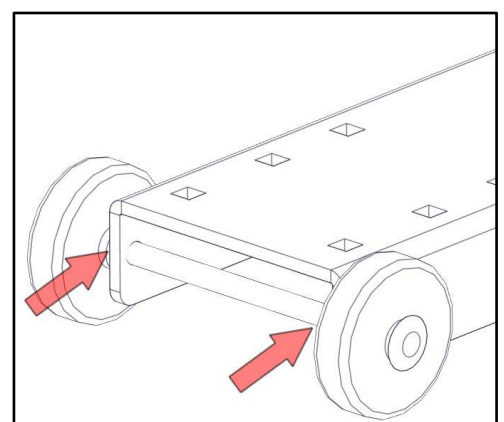
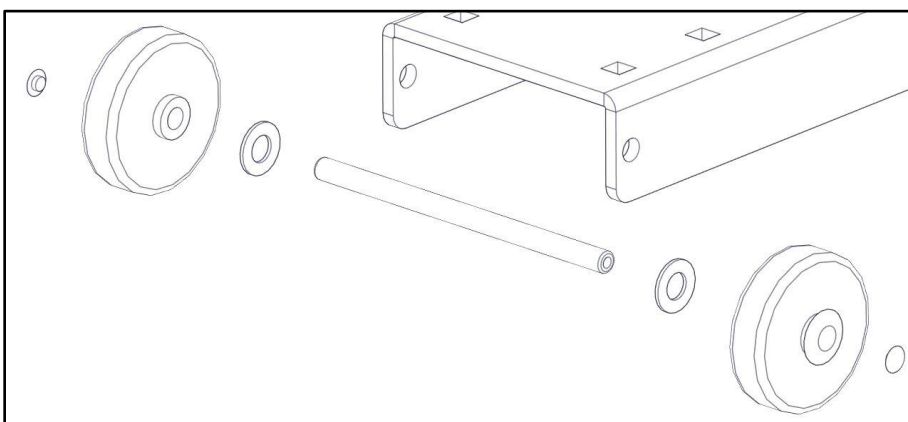

- Rotate the pan perpendicular to the top bow and at a slight angle as shown.
- The pan needs to be maneuvered around the wheels.
- Ensure the wheels are contained inside the pan and lay the pan on top of the bow.

****BE SURE THE WHEEL CAPS DID NOT COME OFF****

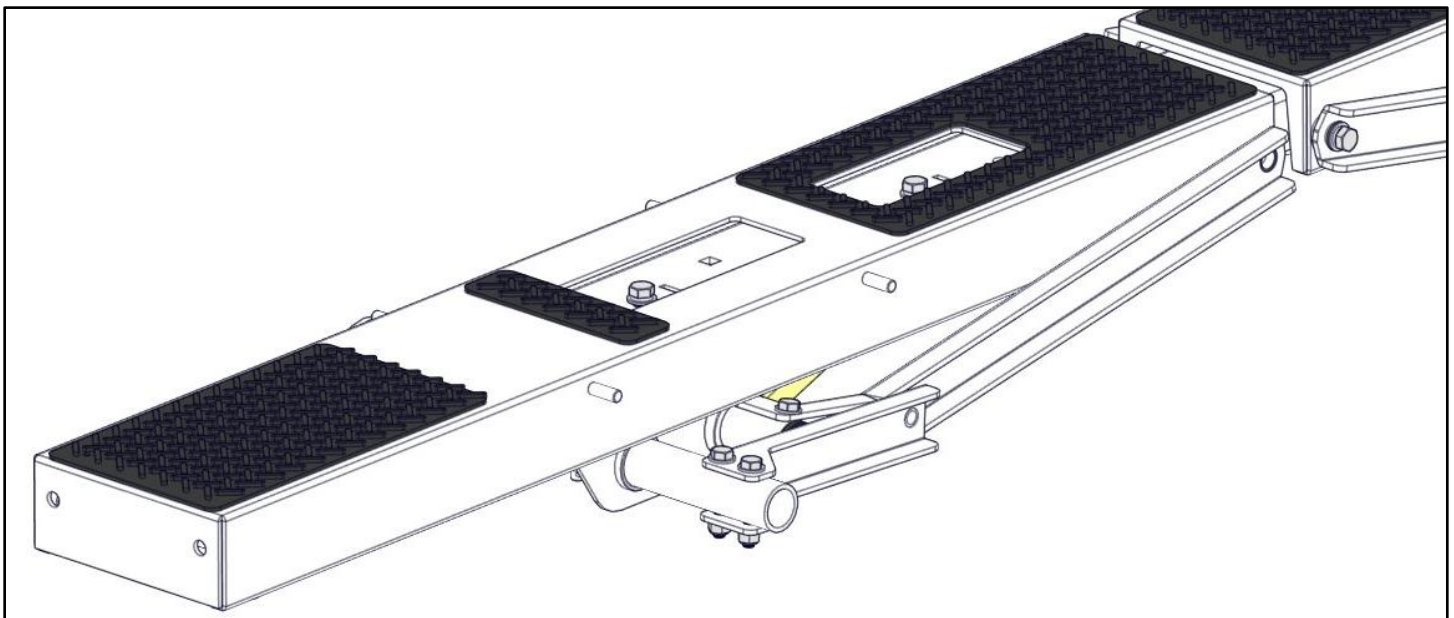
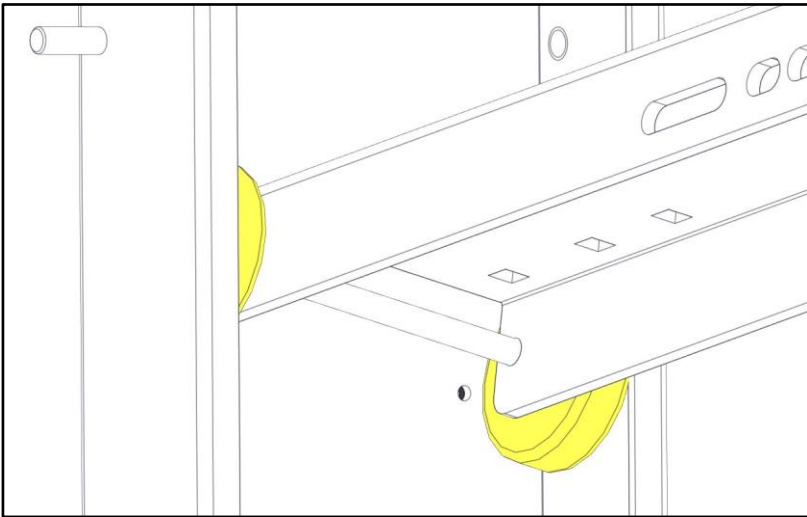
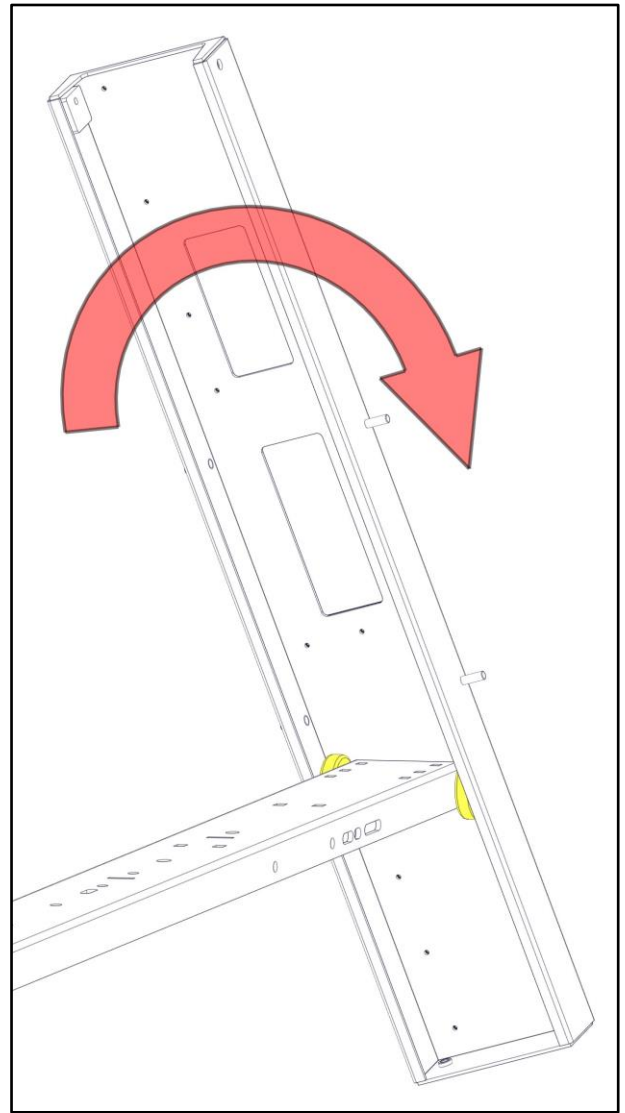

- Remove the hardware that is pre-assembled in the pan assembly (pictures shown without the bow for clarity).

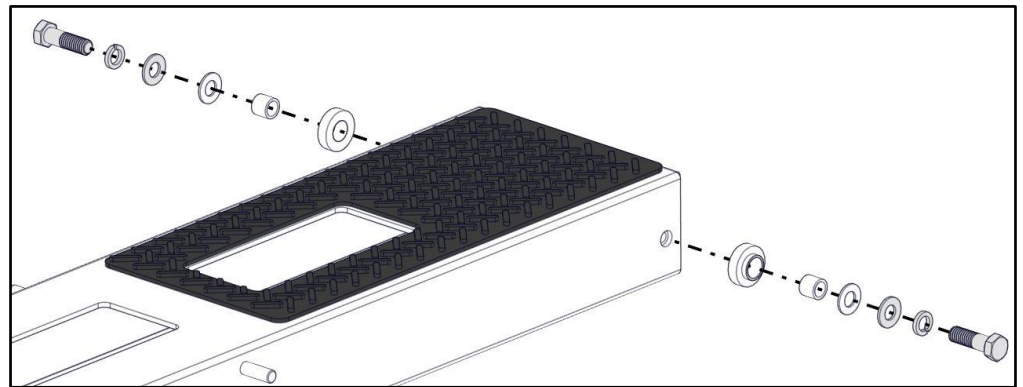

- Place the nylon spacer in between the pan and the arm on both sides.
- The nylon washer goes against the outside of each arm.
- Align the arms from the mechanism assembly with the holes in the pan. Reinstall the previously removed hardware in the orientation shown.
- Do not over tighten. The pan and the arm are designed to rotate against each other.

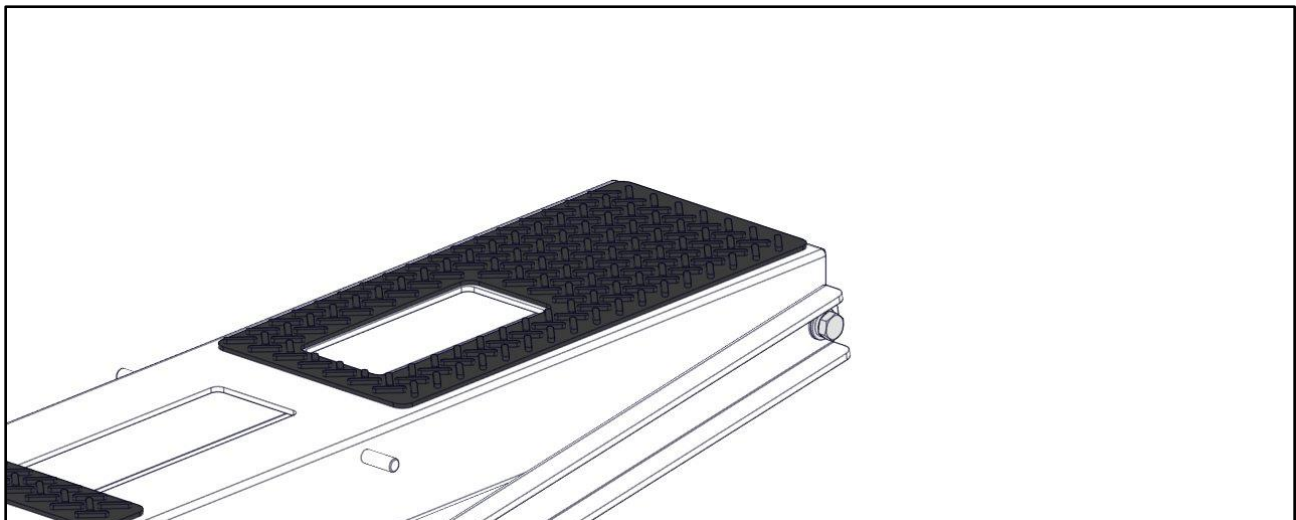
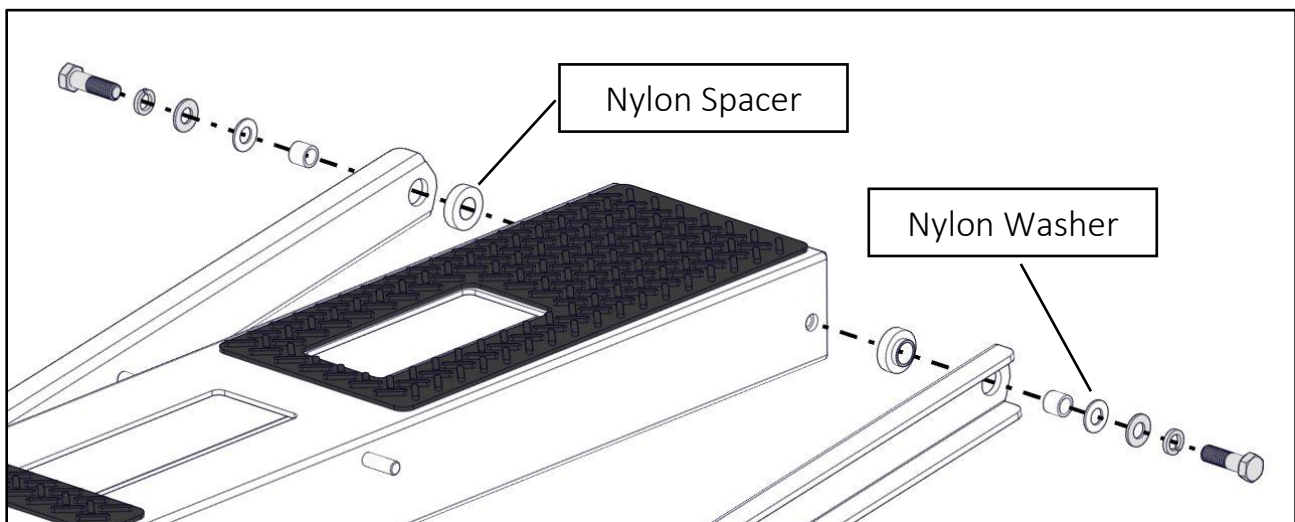

Step 4 – Install Torque Tube

- Determine if the torque tube extension will be needed. Look at the passenger side for reference. The picture shown below shows the rack with the tube extension installed.

Note: The extension is being used in the pictures.

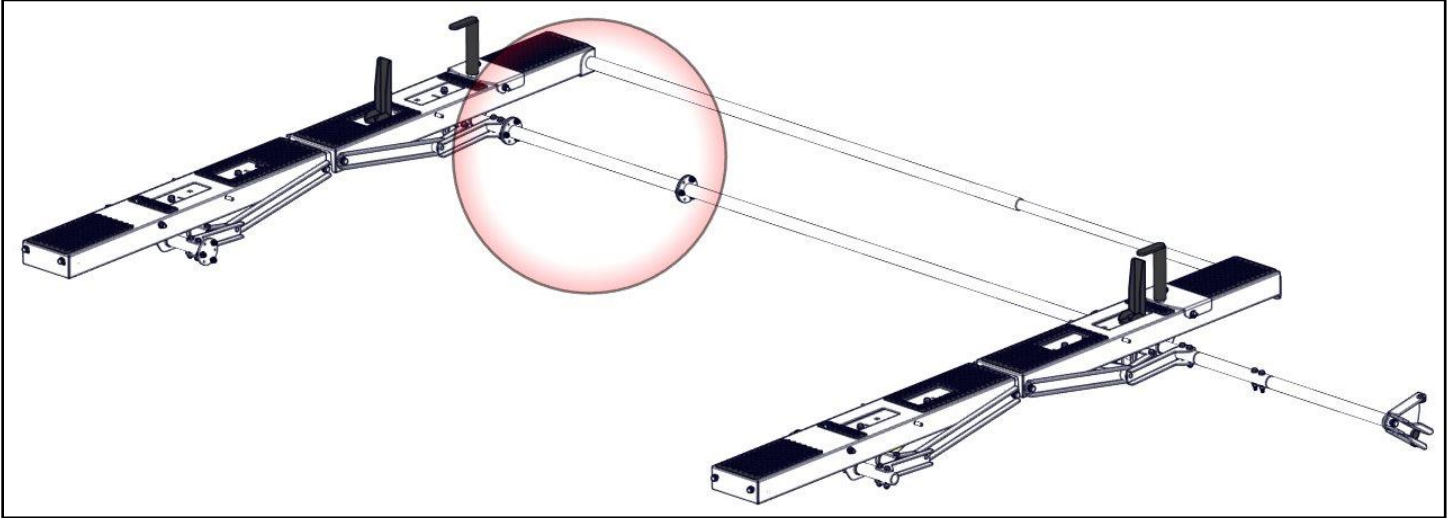

- Bolt the torque tube to the front and rear bow using 1/4" x 7/8" hex head bolts, 1/4" flat washers and 1/4" nyloc nuts. Repeat this process if the extension is being used.
- Snug tighten, but allow movement.

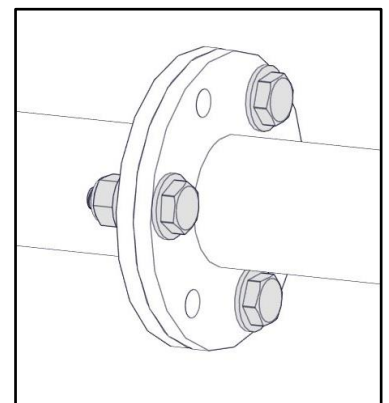
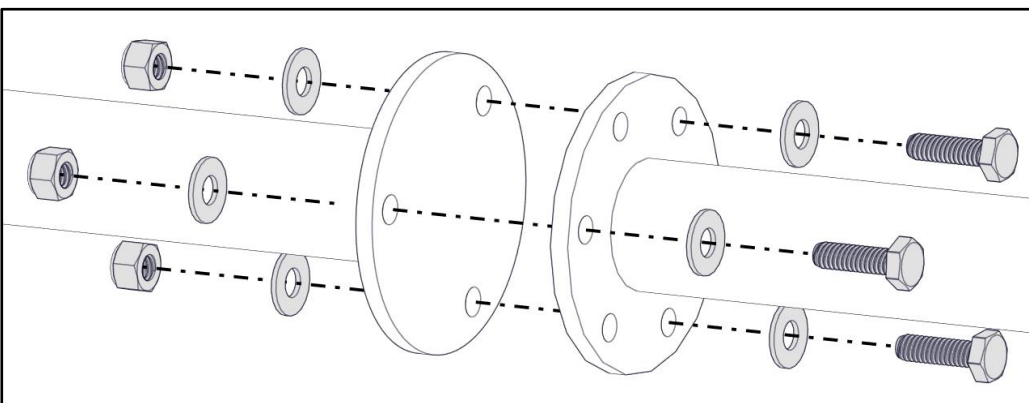
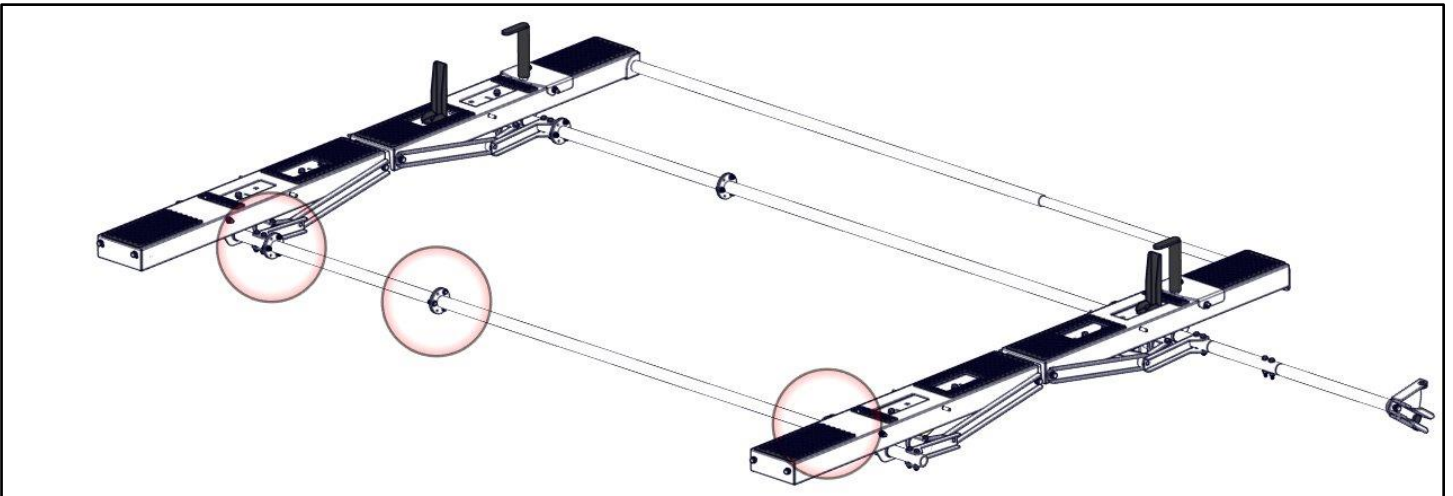

Step 5 – Install End Tube

- Bolt the end tube assembly to the end of the pan on the front and rear bow using 5/16" x 3/4" hex head bolts, 5/16" lock washers and 5/16" flat washers.
- Snug tighten, but allow movement.

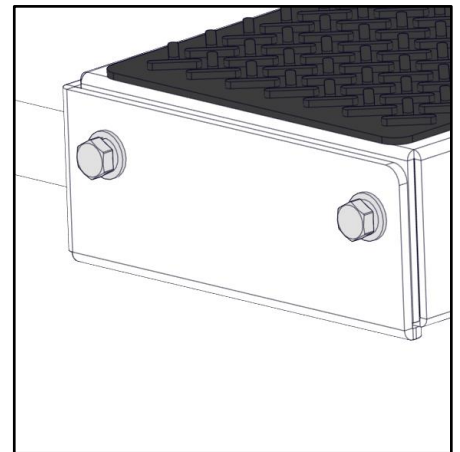
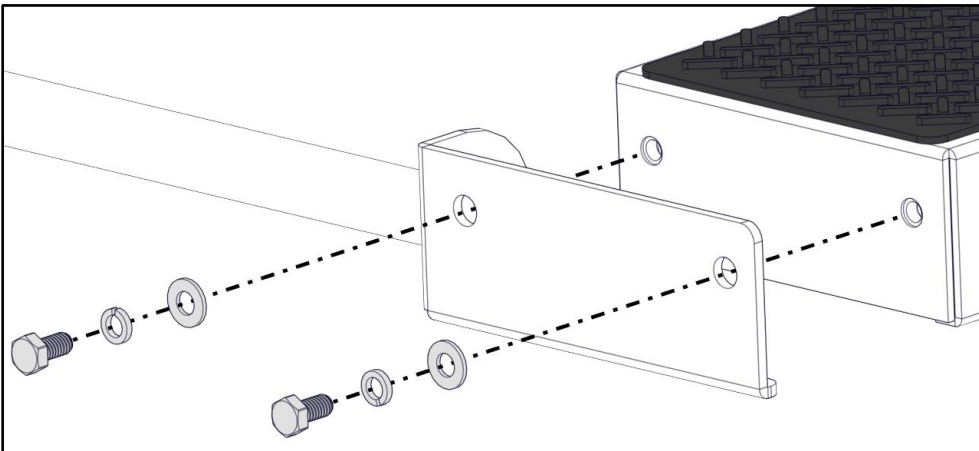
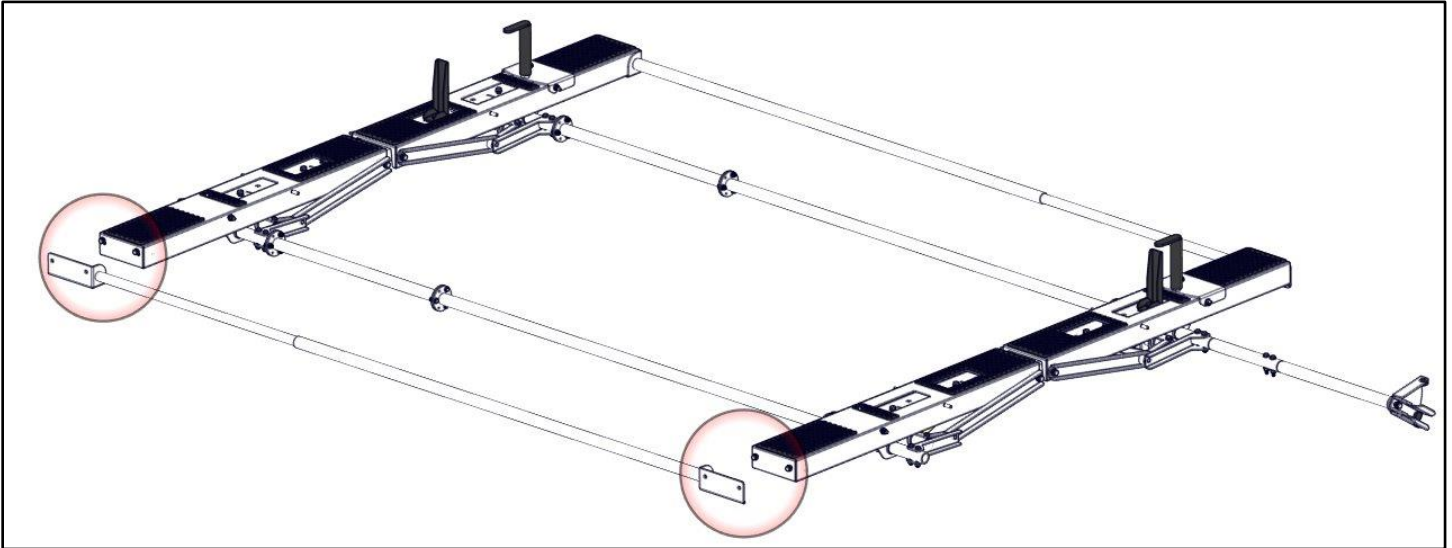

Step 6 – Install Actuator

- Remove the hardware, as shown, from the tube on the rear bow.
- Insert actuator extension into the tube and attach using the previously removed hardware.

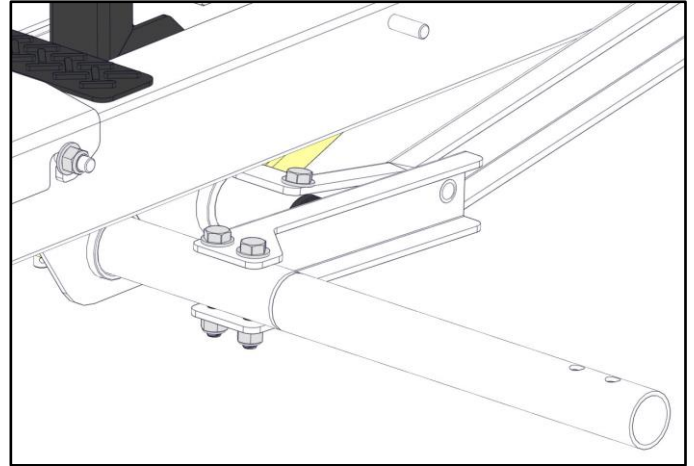
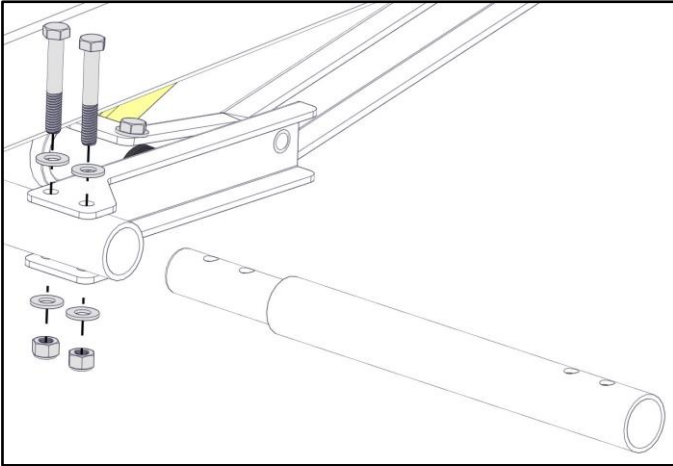

- Insert actuator assembly into the end of the actuator extension as shown below.
- Bolt into place using two 5/16" x 1-3/4" hex head bolts, four 5/16" flat washers and two 5/16" nyloc nuts.
- Tighten.

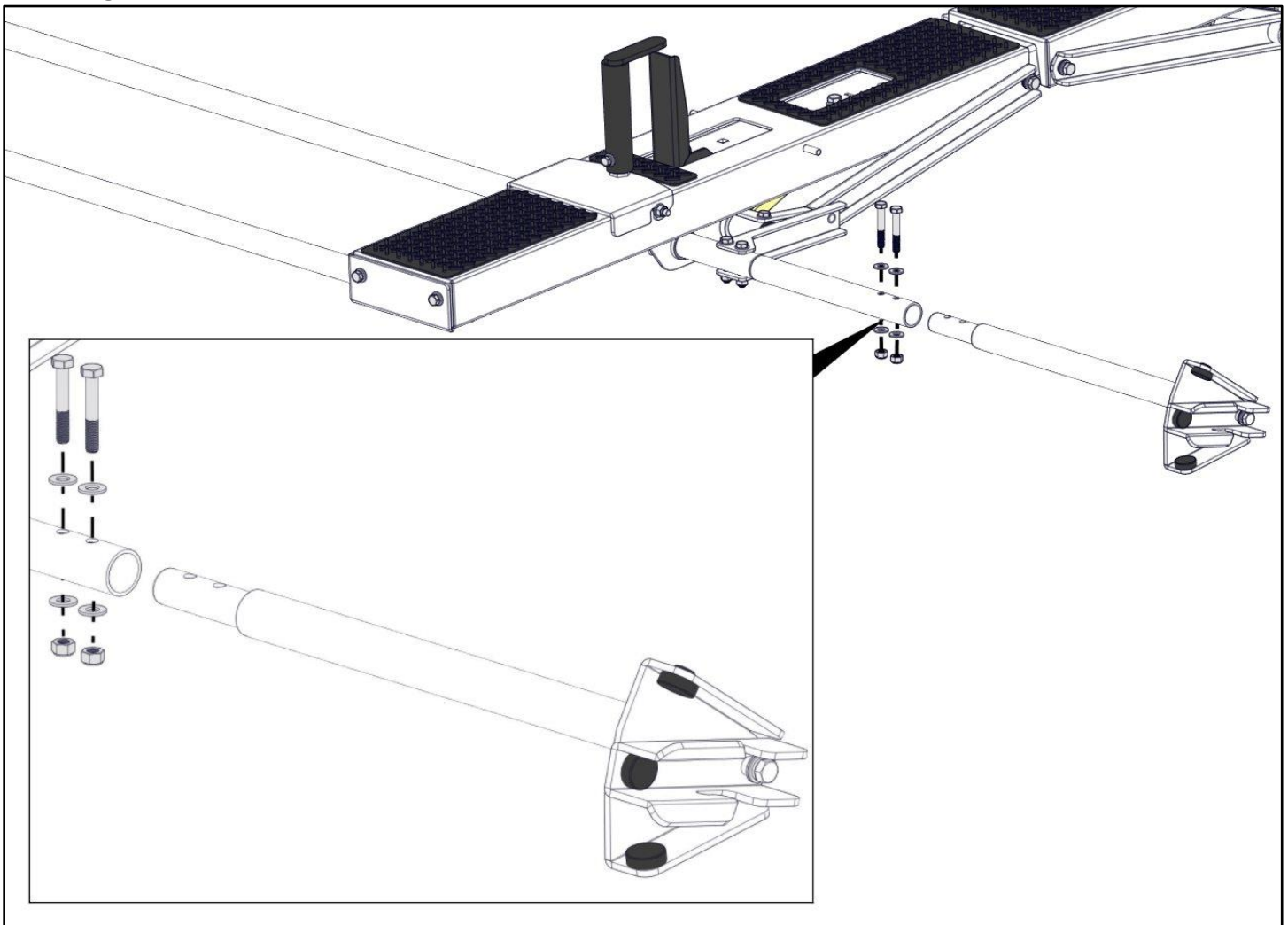

Step 7 – Install Gas Springs on Rear Bow

- Remove the pin, spacer and the nylon washers that are pre-assembled in-between the gas springs from the rear bow mechanism.

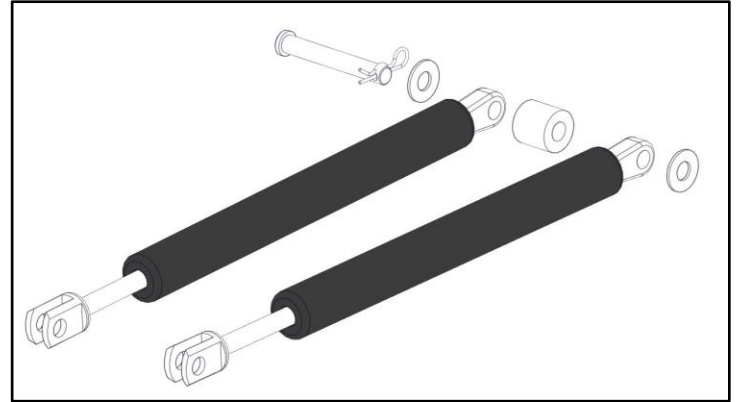

- Rotate the pan to a position so the mounts on the mechanism will allow the gas springs to be installed.
- Use the pin, spacers and the nylon washers that were removed to attach the gas springs to the gas spring mount on the underside of the rear bow. The spacer goes in between the two gas springs. The nylon washers go in between the gas springs and the mount.

Note: In some situations, these gas springs can be installed easier by using the handle to help pivot the pan. The orientation of the gas springs may vary.

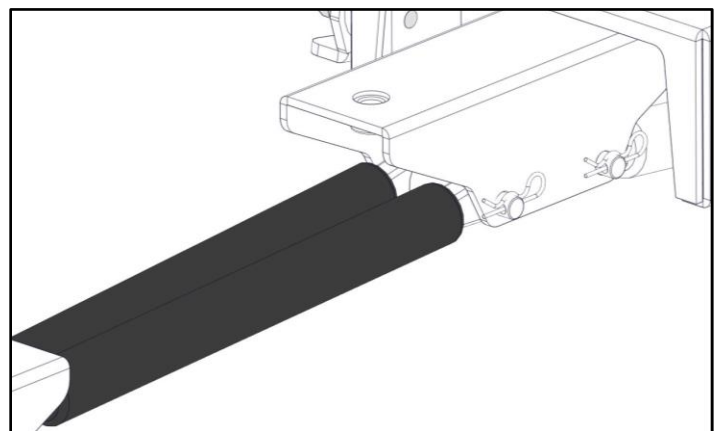
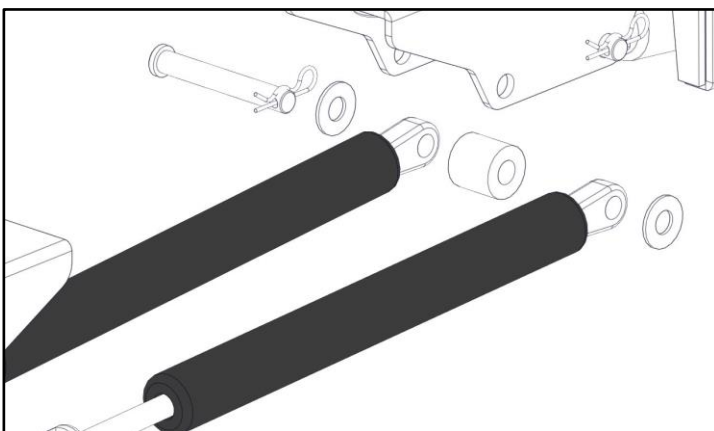
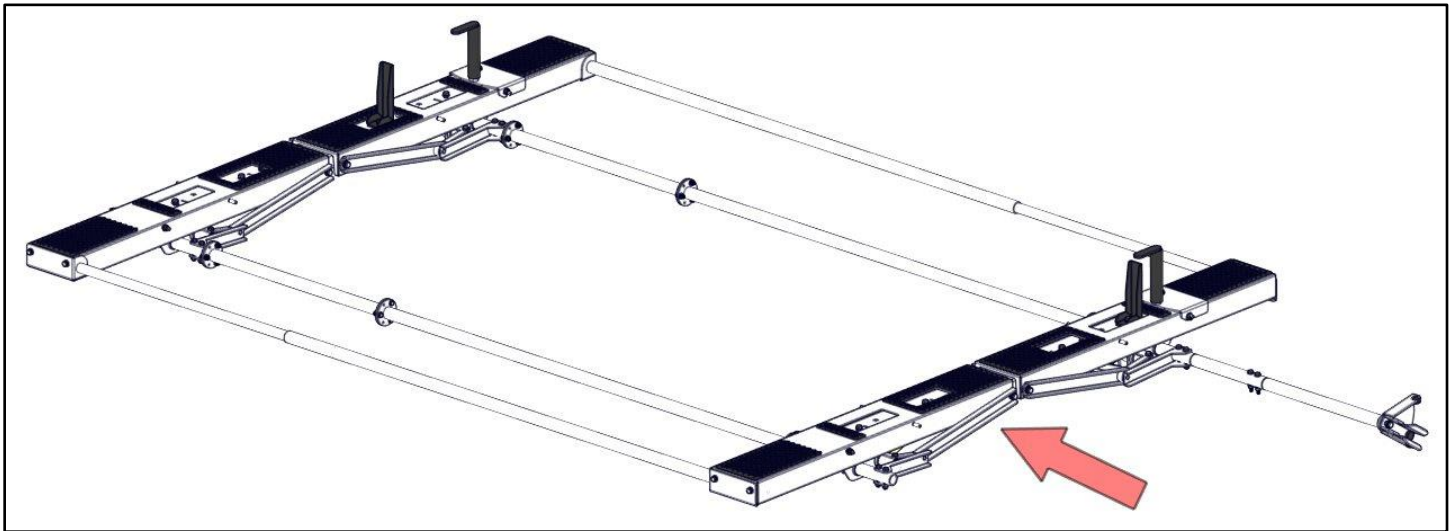

Step 8 – Install Ladder Hooks

- Assemble the ladder hooks.

Note: This can be adjusted at a later time to better fit the size of the ladder being used.

- Bolt together using 1/4" x 7/8" hex head bolt, 1/4" lock washer and a 1/4" flat washer.
- Repeat for a second ladder hook.
- Tighten.

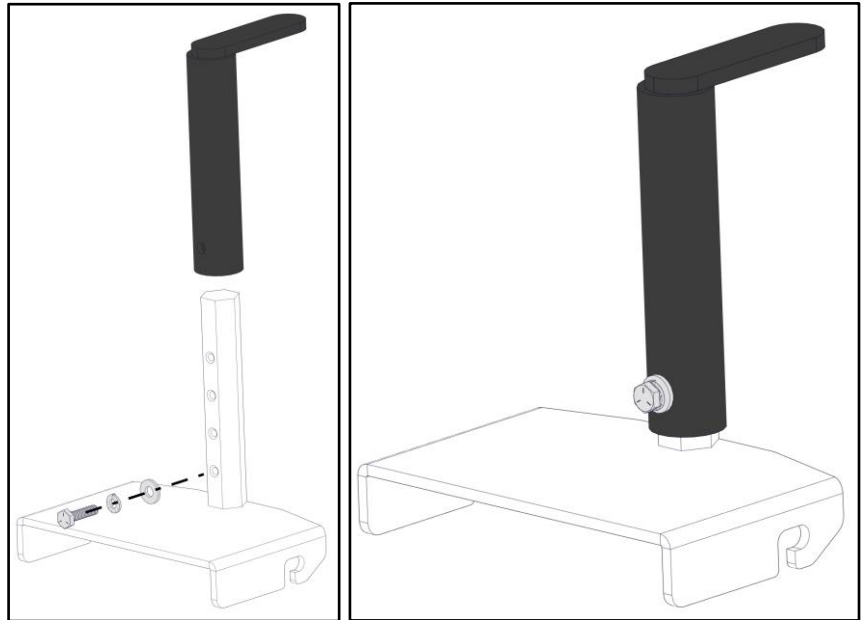

- Place one ladder hook assembly onto the front bow and one ladder hook on the rear bow.
- There are two threaded studs to choose from on each bow. The ladder being used on the ladder rack will determine which location is used.

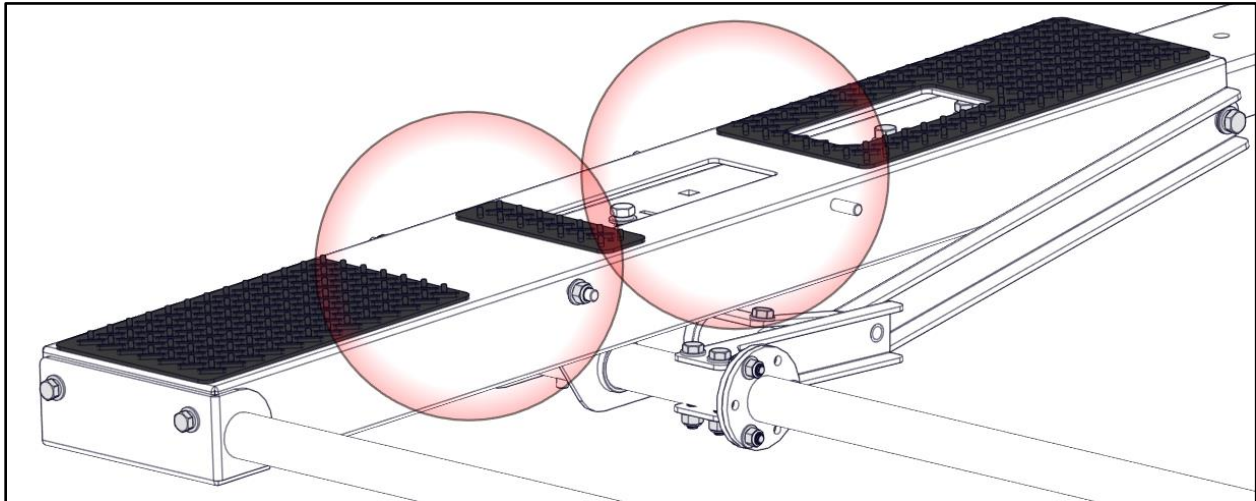

- Bolt into place using the pre-assembled hardware on both front and rear pan.

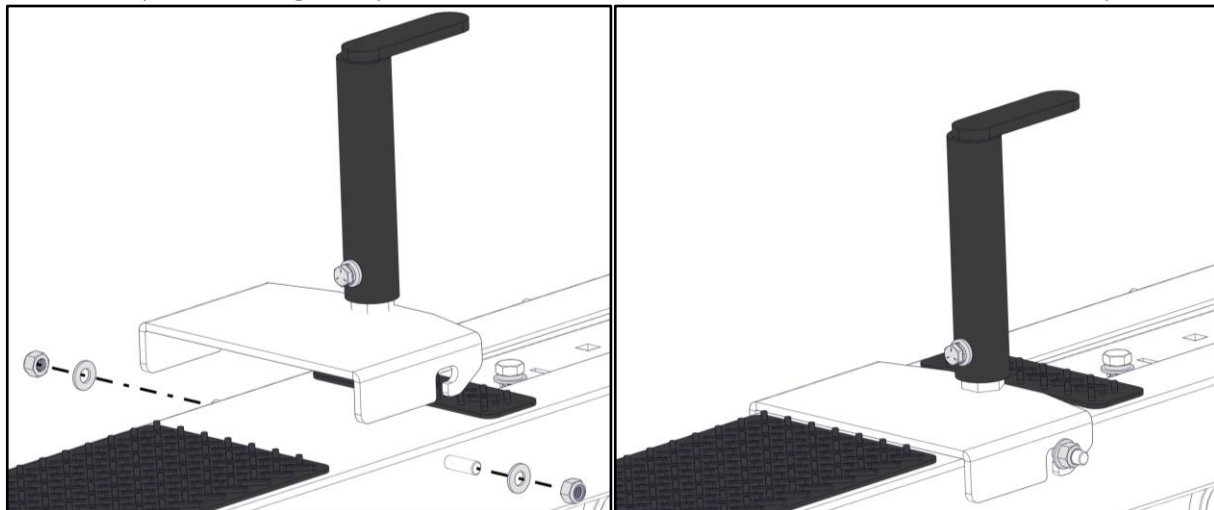

Step 9 – Install Ladder Stop

- Find the slot and the installed hardware near the previously installed ladder hook assembly.
- Remove the hardware in the bow and place the ladder stop in that location. Bolt into place using the removed hardware. Be sure the tab on the ladder stop aligns with the slot in the bow.
- Repeat on each bow.
- Tighten.

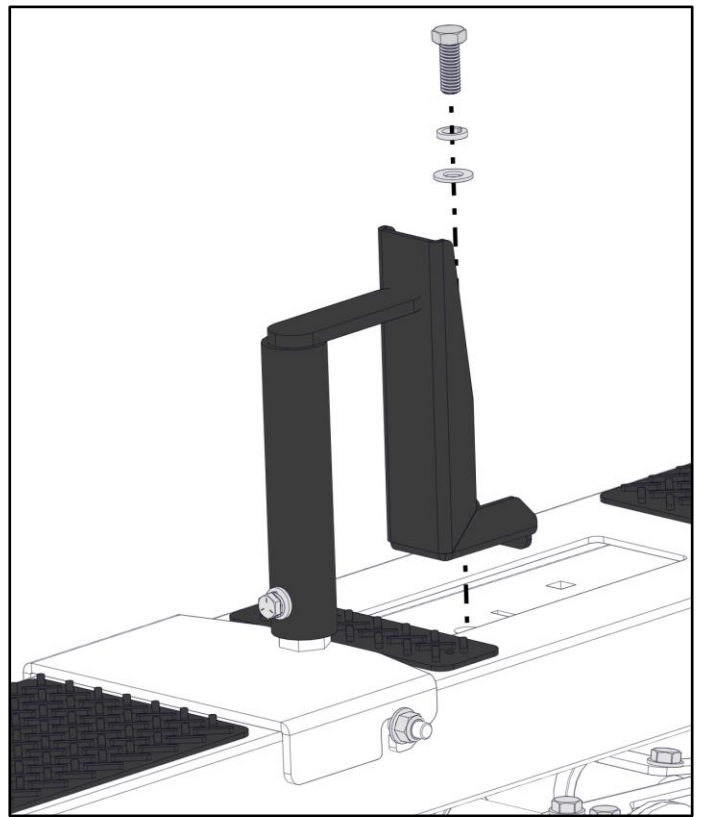
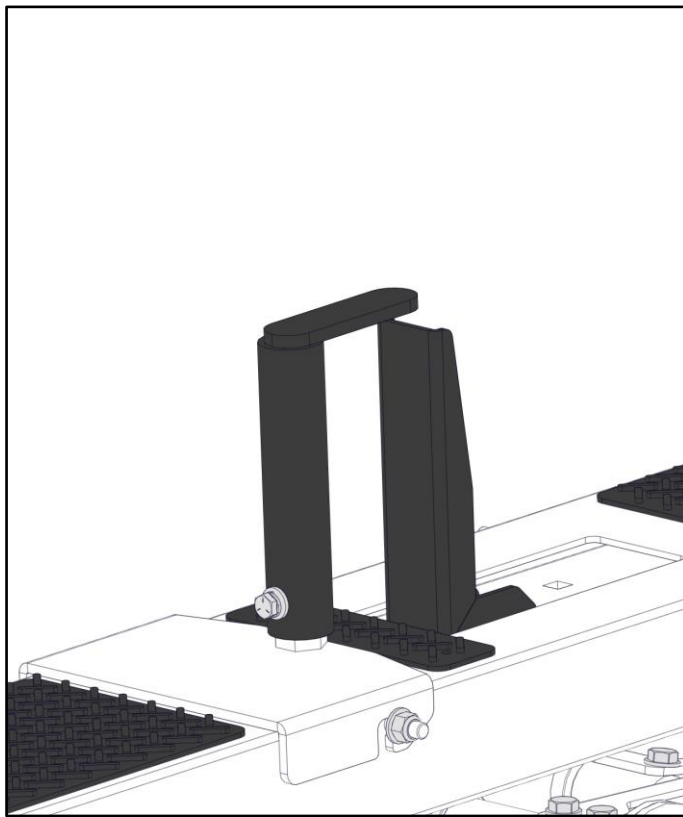
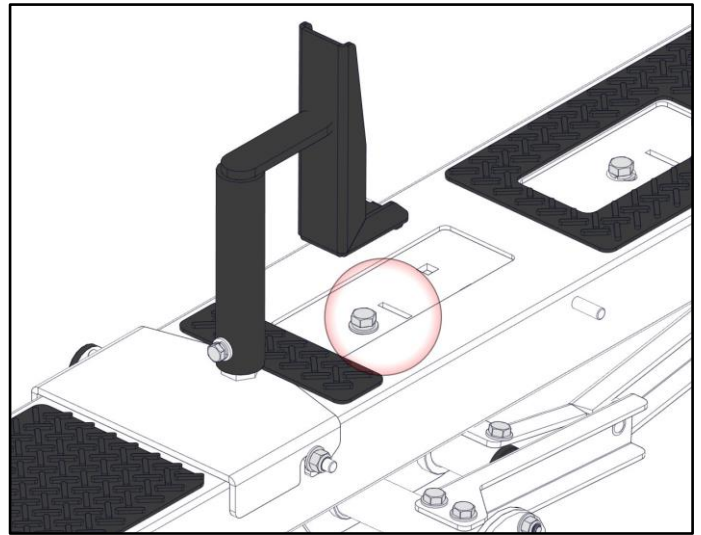

Step 10 – Test Ladder Rack

- Go back and ensure all hardware is tight. Start with tightening the torque tube first.
- Prior to installing a ladder, place the long handle into the handle bar assembly and test that the ladder rack mechanism works correctly.

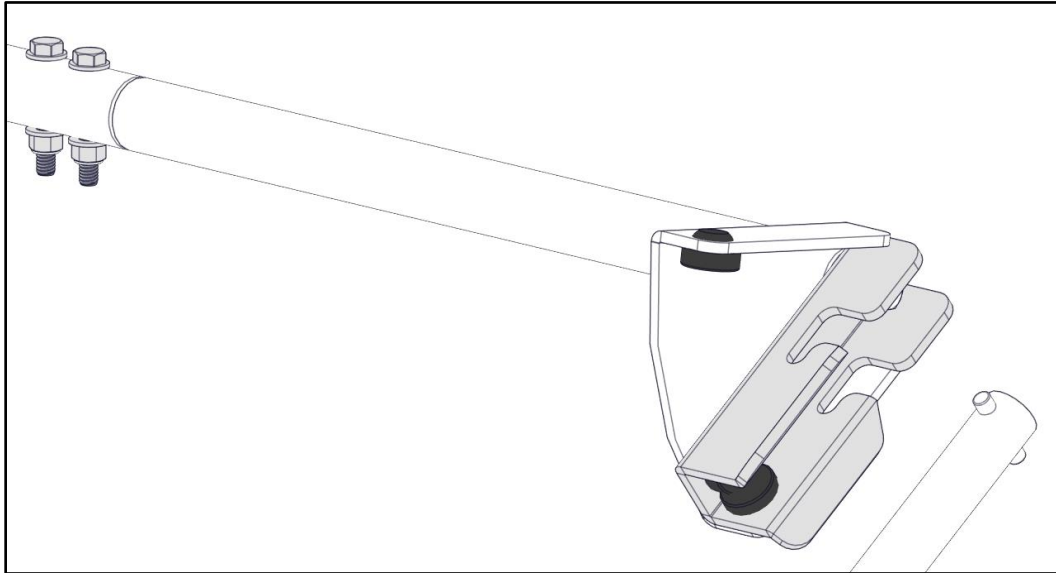

ENSURE ALL HARDWARE IS TIGHT
YOUR INSTALLATION IS NOW COMPLETE

