

---

# **KARGO MASTER<sup>®</sup>**

**WE PUT EVERYTHING WITHIN REACH.**

---

## Instruction Guide

---

4081L

---

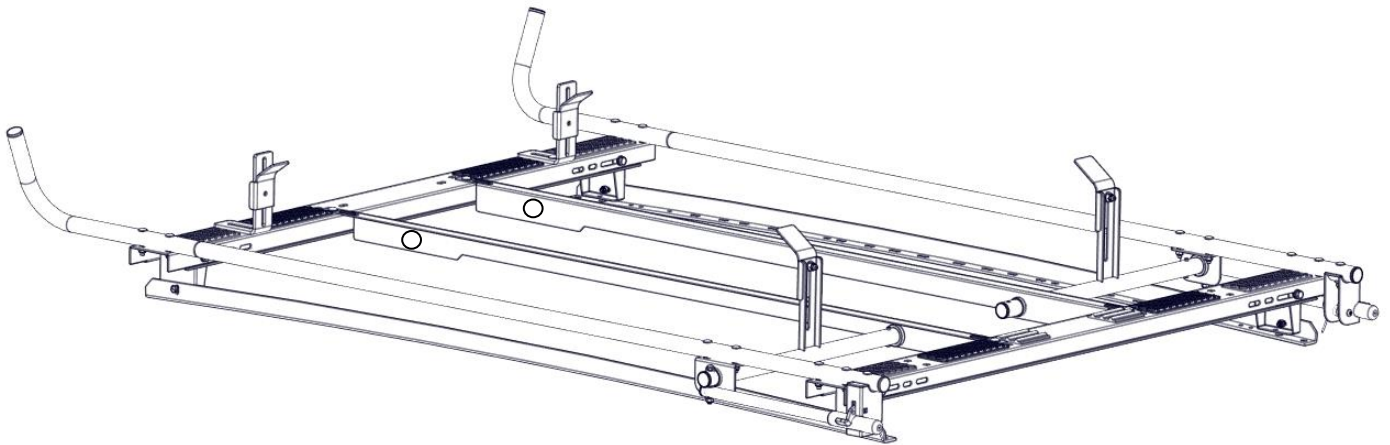

---

**\*PLEASE READ ALL INSTRUCTIONS AND WARNINGS PRIOR TO ASSEMBLING,  
INSTALLING, AND USING THIS PRODUCT\***

---

### Warning



Always check for wires, fuel tanks and lines, brake lines and other important vehicle functionality items prior to drilling and installing all products.

---

### Tools Needed



9/16" Socket and Wrench	1/2" Socket and Wrench
-------------------------	------------------------

---



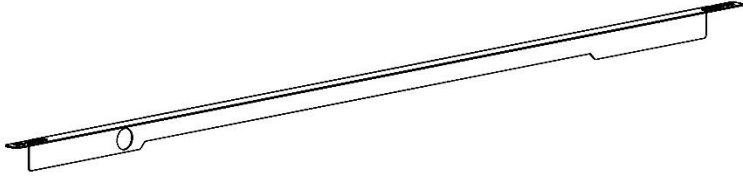
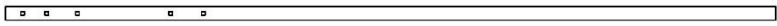

### Before You Begin

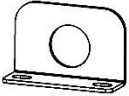
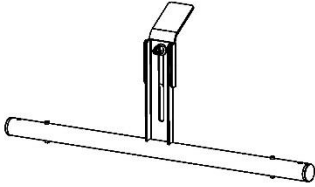
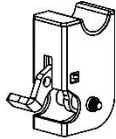
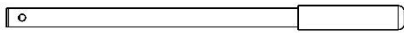
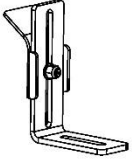
- Read all instructions. Find your vehicle roof rail mounting prior to rack assembly.
  - Be sure to put E6000 sealant around all threads entering cargo area and between the rubber spacer and roof of vehicle to prevent water from leaking into cargo area.
  - **DO NOT EXCEED MANUFACTURERS WEIGHT CAPACITY FOR ROOF**
  - **PLACE ANTI-SEEZE ON ALL THREADS**
-

## Parts

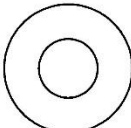
ITEM NO.		PART NUMBER	DESCRIPTION	QTY.
A		11-03005-R2-L	DS LONG ANGLE BRK	1
B		40800-50-001	TUBE	1
C		40800-50-002-R1-L	DS BEND TUBE	1
D		11-03027	ANGLE BRK	1
E		13-03007-R1	PIVOT LADDER CLAMP ASM	1
F		40813-44	HANDLE CLAMP ASM	1
G		13-03008-R2	HANDLE ASM	1
H		13-03009	LADDER CLAMP ASM	1
		18-4081L	HARDWARE	1

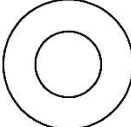
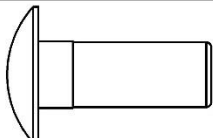
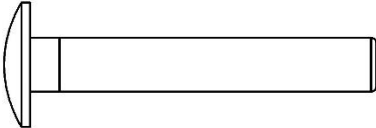
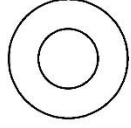
Assembly Hardware (18-4081L)

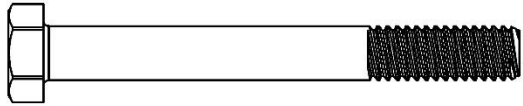
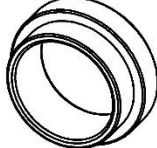
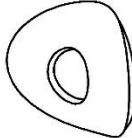
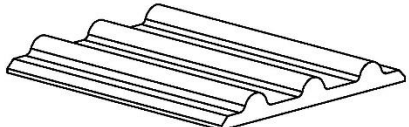
ITEM NO.	TO SCALE	PART NUMBER	DESCRIPTION	QTY.
1		90295A160	.06x.34x.75 Nylon Washer	2
2		.375-16 NYLOC	3/8-16 Nyloc Nut	3
3		.375 FLAT WASHER	3/8 Flat Washer	3
4		.375-16 x 1 Carriage	3/8-16x1 Carriage Bolt	3
5		.312-18x2.0 CARRIAGE BOLT	5/16-18x2.0 Carriage Bolt	7
6		96659A107	5/16 FLAT WASHER	8
7		91831A030	5/16 NYLOC	8
8		.312-18 X 2.75 HEX BOLT	5/16-18x2 3/4 Hex Bolt	1
9		40800-10-007		2
10		91844A230	5/16 CONTOUR WASHER	1
11		Extra Rubber Pad	1:2 SCALE	1

### Step 1 – Remove Ladder Stops

- If havent already done so, remove ladder stops from opposite end of both bows where the clamp and lock is installed.

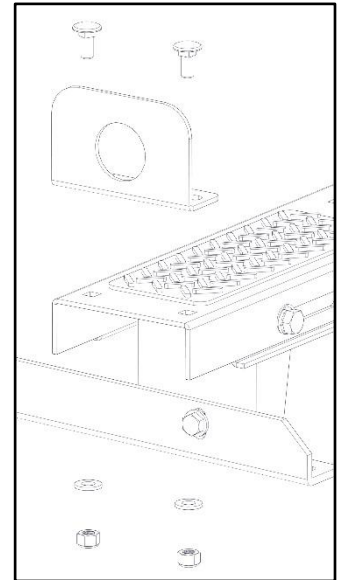
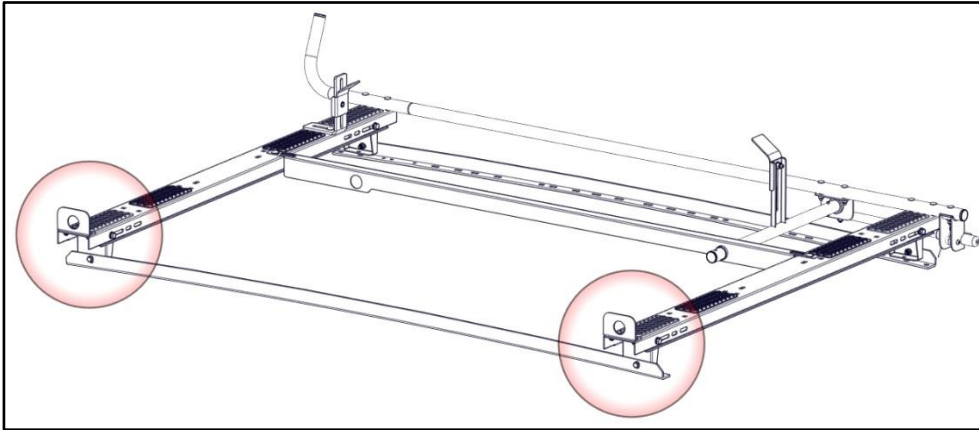

## Step 2 – Mount Side Tube

- Place a generous amount of E6000 into the tube connection.
- Place side tube on top of installed bows.
- Have the bend towards the front of the vehicle as shown.
- Mount rotation bar plate to the rear of the tube as shown.
- Leave one square slot open at the rear.
- Bolt together using 5/16" x 1-3/4" carriage bolt, a 5/16" flat washer and a 5/16" nyloc.
- Snug Tighten, but allow movement.

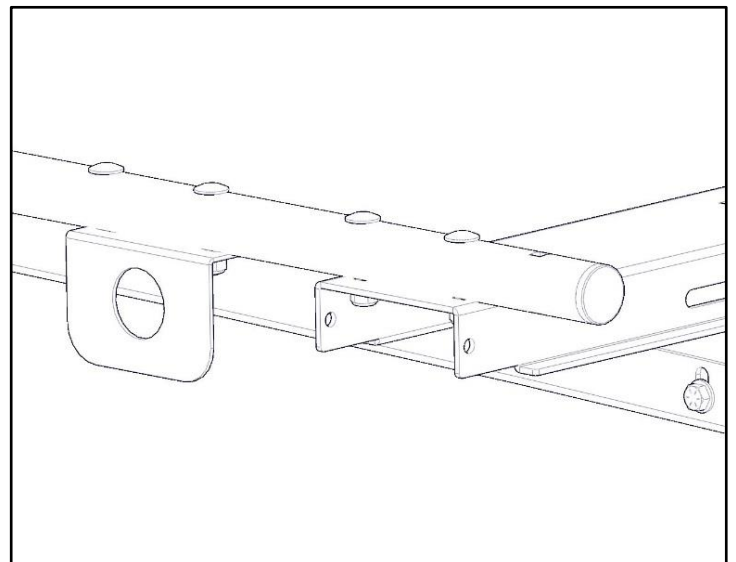
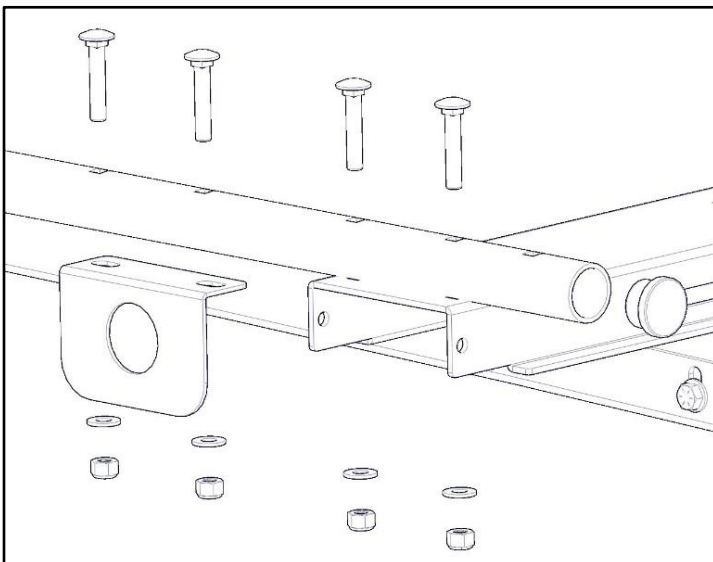
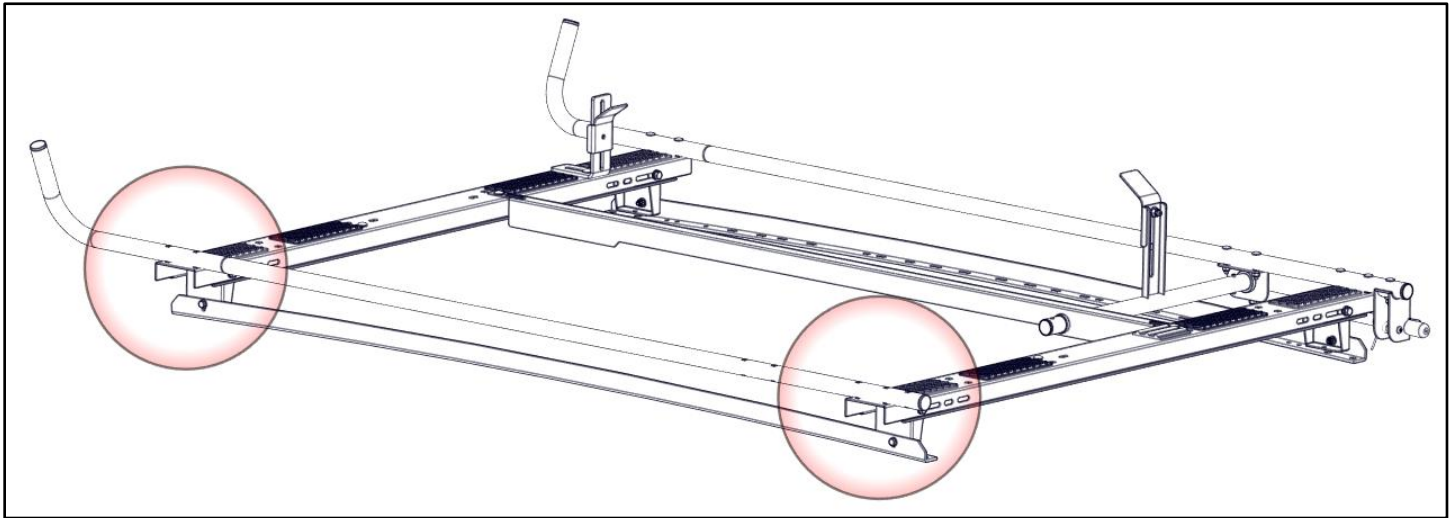
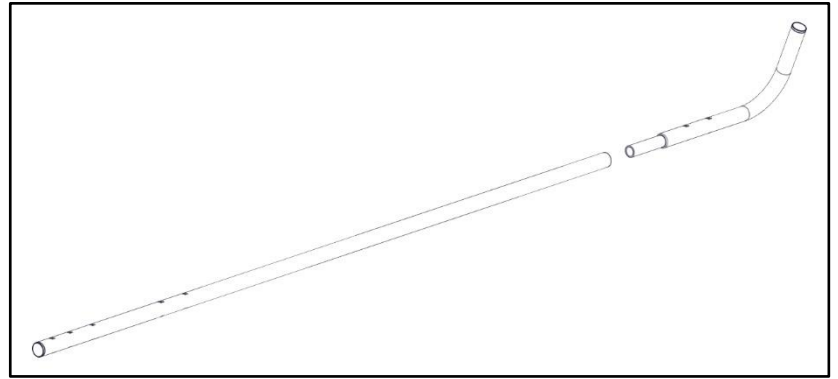

### Step 3 – Mount Clamp Tube

- Place clamp and lock L bracket on top of installed bows. Do not install hardware right now.
- Insert plastic bushings into the clamp and lock L bracket and the rotation bar plate installed in Step 2, with flanges as shown so they cannot come out at a later time. If bushings are not placed in correct orientation, they can fall out.

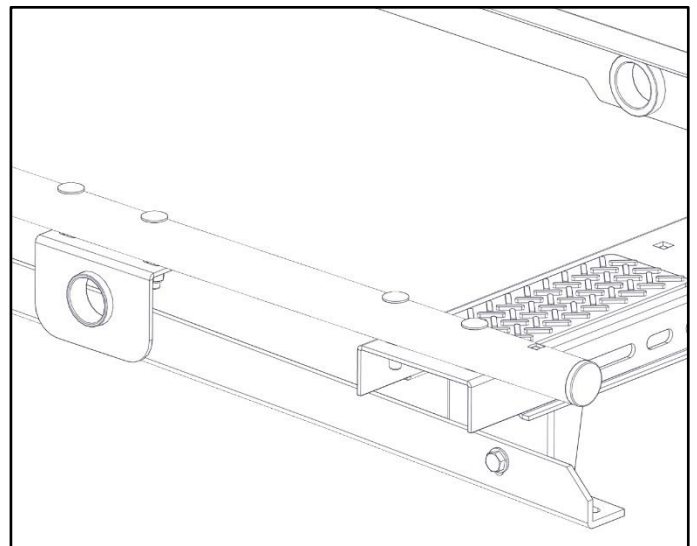
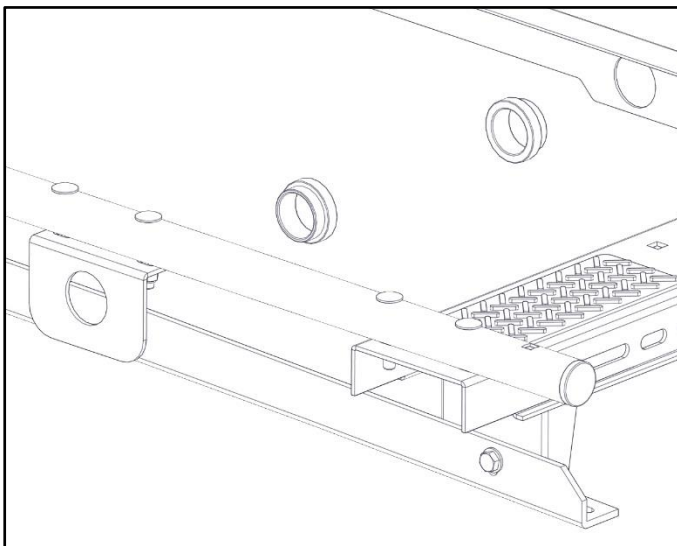
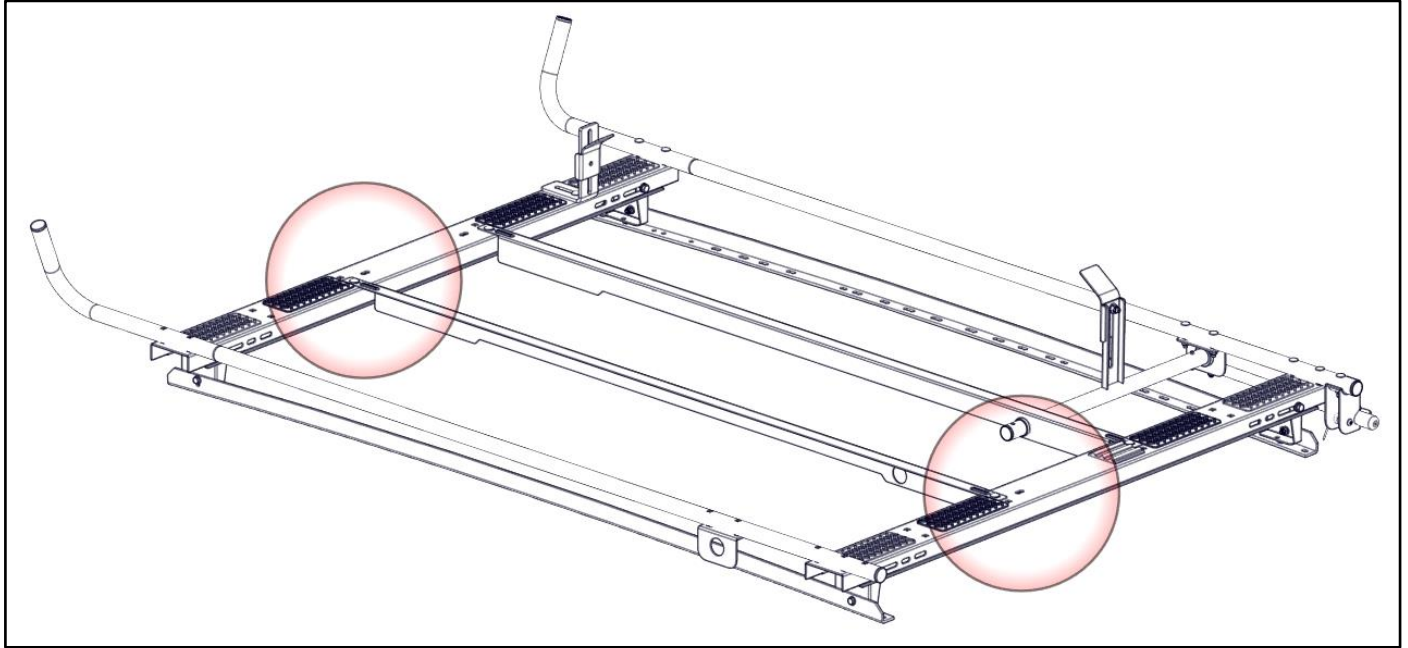

- Insert clamp tube into both plastic bushings.
- Adjust clamp on clamp tube to fit firmly against your ladder.

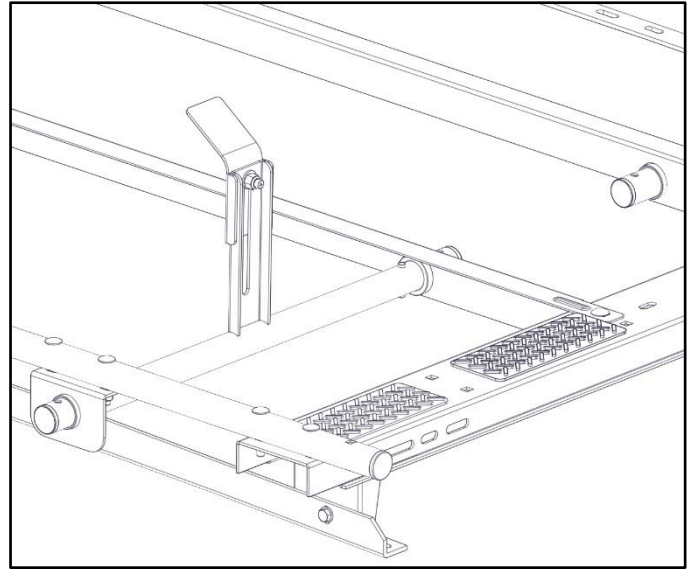
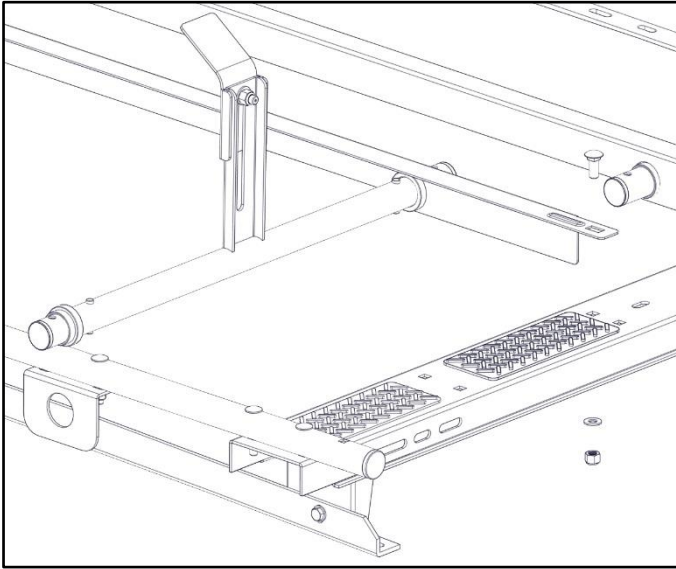

- Bolt clamp and lock L bracket to bows using 3/8" x 1" carriage bolt, 3/8" flat washer and a 3/8" nyloc as shown. (This view shown without clamp tube)
- TIGHTEN

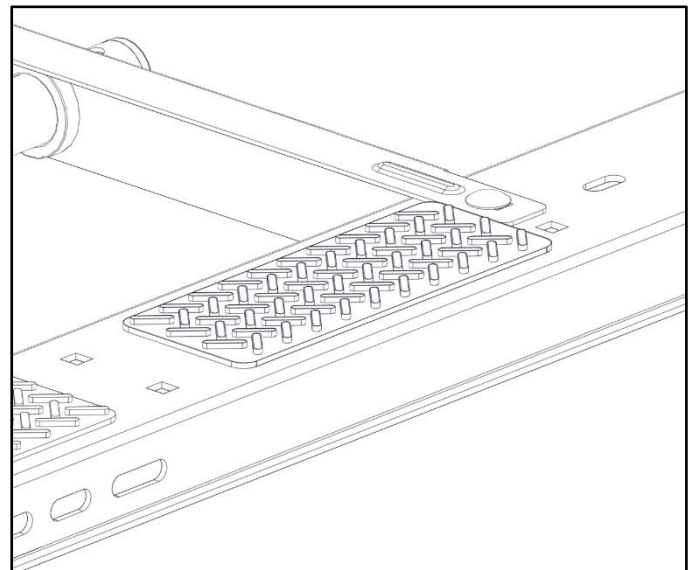
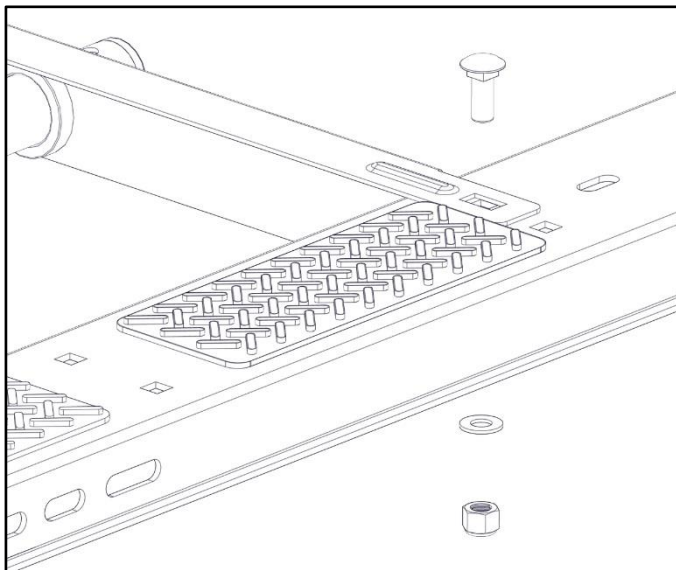



### Step 4 – Mount Handle

- Bolt handle to clamp tube using a 5/16" x 2-3/4" hex head, two 5/16" flat washers, 5/16" nylon washer and 5/16" a nyloc. The nylon washer goes in between the clamp tube and handle.
- TIGHTEN

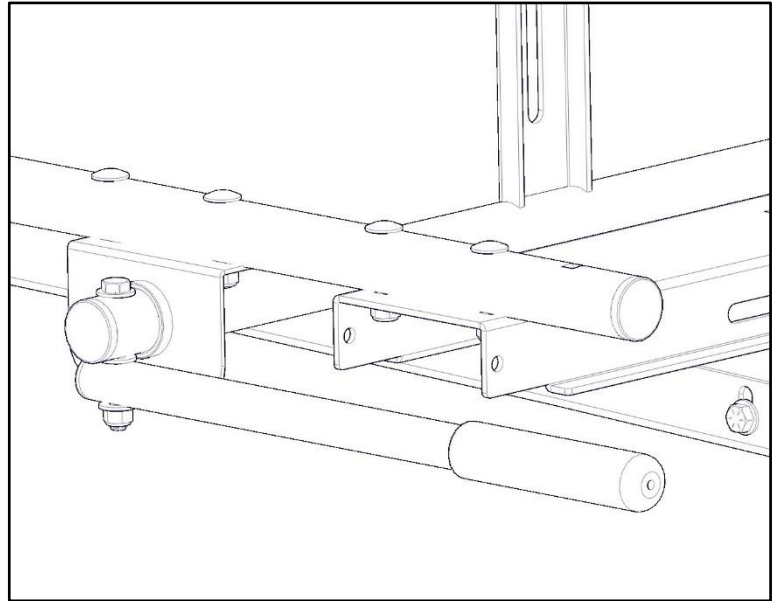
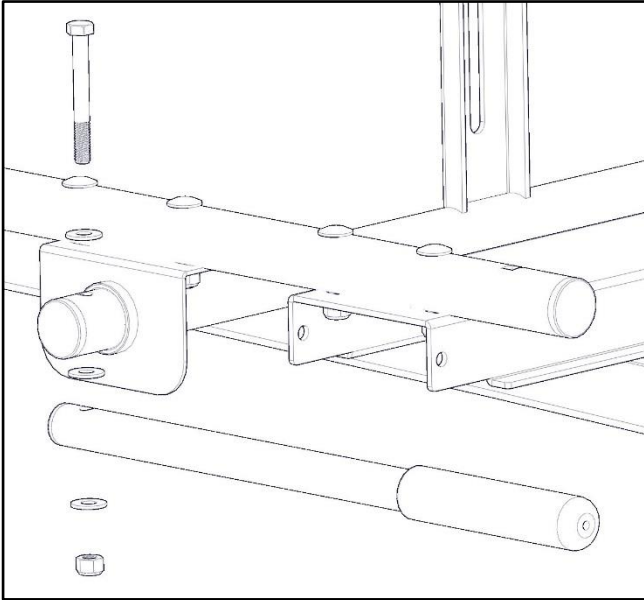

### Step 5 – Mount Latch Assembly

- Bolt latch to the rear of the mount tube that was installed in Step 5 using 5/16" x 1-3/4" carriage bolt, 5/16" curved washer and a 5/16" nyloc.
- TIGHTEN

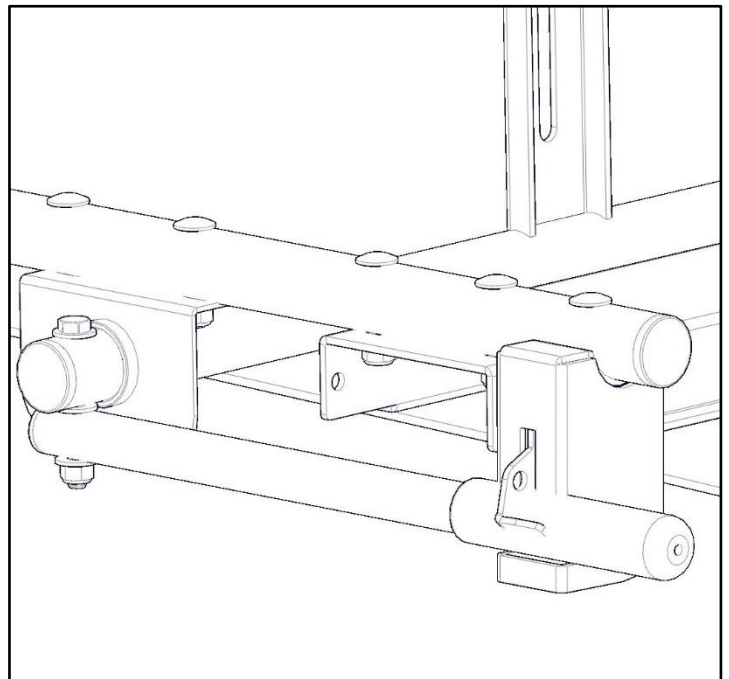
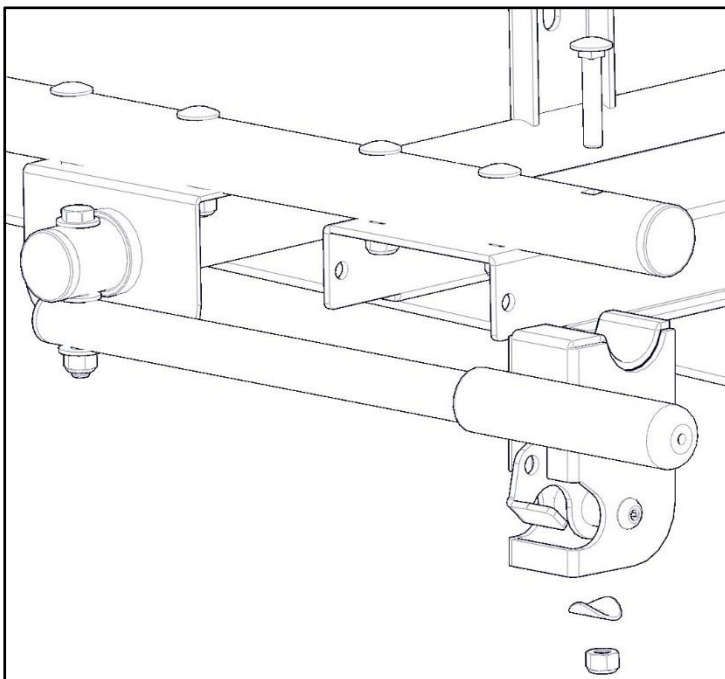

## Step 6 – Mount Ladder Hook

- Bolt ladder hook bracket to the bow in the orientation shown using a 3/8" x 1" carriage bolt, a 3/8" flat washer and a 3/8" nyloc. Be sure the bracket is square to the bow.
- Adjust clamp on bracket to fit firmly against your ladder.
- TIGHTEN

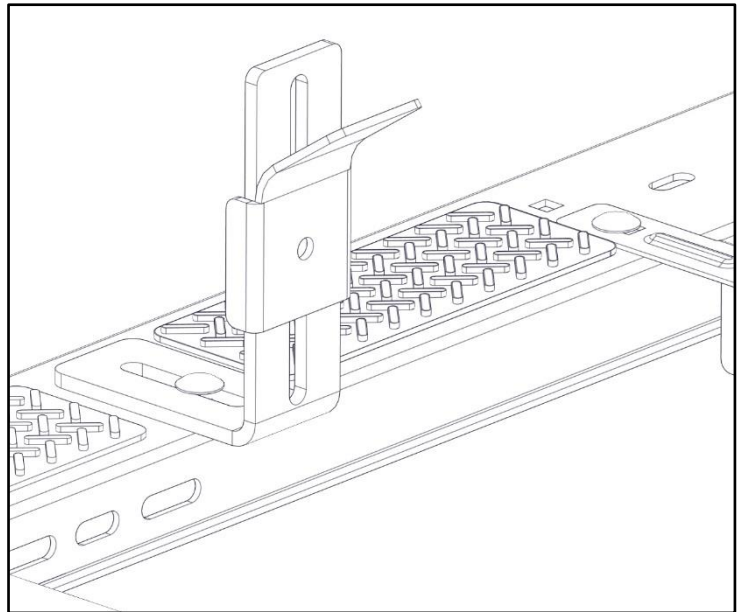
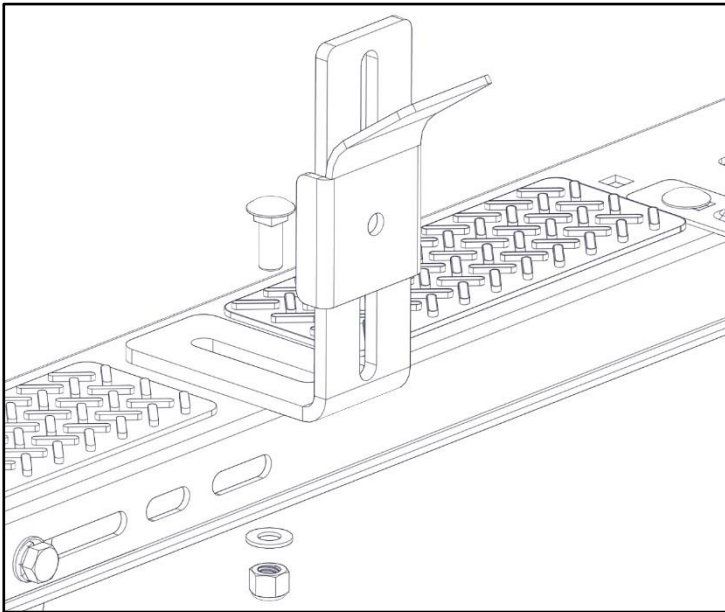

GO BACK AND ENSURE ALL HARDWARE IS TIGHT  
Your installation is now complete.

## 40933 Parts List

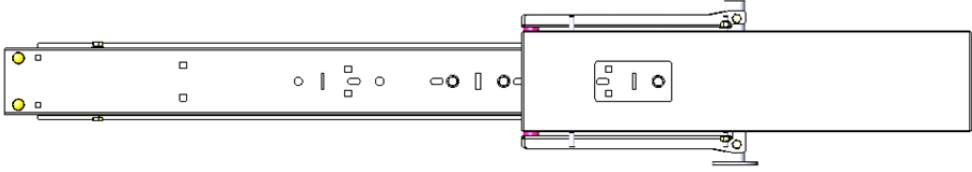

Front Bow Assy. (1)

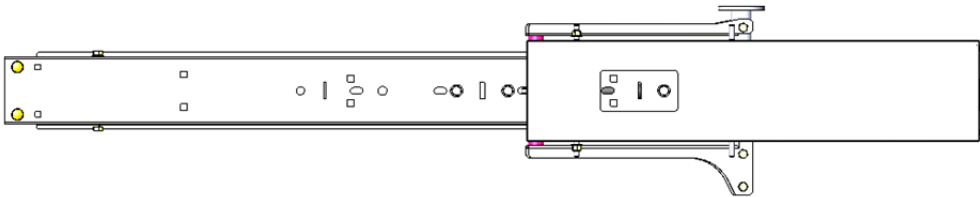

Rear Bow Assy. (1)



Rail Mount Foot (4)



Latch (1)



Ladder Hook (2)



Ladder Stop (2)



Torque Tube (1)



Ladder Pan Stiffener (1)



Mount Rail (2)

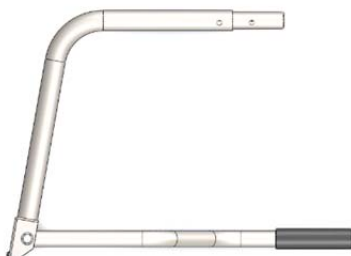

Handle Assy. (1)

# 40933 Hardware List

## Tools Needed

8' Tape Measure	1/2" End Wrench
1/2" Socket	9/16" End Wrench
9/16" Socket	Hammer
7/16 Socket	

## Hardware Pack

(a)  
Qty 6 -  
5/16"-18 x 3/4" Carriage Bolt



(b)  
Qty 26 -  
5/16" Flat Washer



(c)  
Qty 8 -  
5/16" Lock Washer



(d)  
Qty 14 -  
5/16"-18 Nyloc Nut

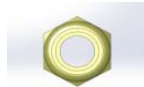

(e)  
Qty 4 -  
5/16"-18 x 5/8" Hex Bolt

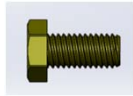

(f)  
Qty 6 -  
Round Rubber pad



(g)  
Qty 4 -  
Fender Washer - 24mm OD x 2mm TK



(h)  
Qty 4 -  
M8 Nyloc nut

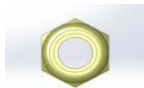

(i)  
Qty 4 -  
5/16"-18 x 1" Hex Bolt



(j)  
Qty 8 -  
3/8"-16 x 3/4" Hex Bolt

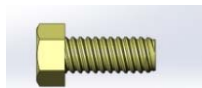

## Hardware Pack Cont'

(k)  
Qty 8 -  
3/8" Flat Washer



(l)  
Qty 8 -  
3/8" Lock Washer



(m)  
Qty 6 -  
1/4"-20 x 7/8" Fully Threaded Hex Bolt

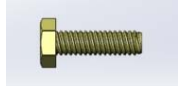

(n)  
Qty 12 -  
1/4" Washer



(o)  
Qty 6 -  
1/4"-20 Nyloc Nut



(p)  
Qty 4 -  
M8 x 25mm Hex Bolt

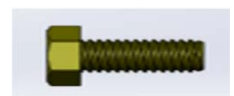

(q)  
Qty 2 -  
M8 x 20mm Counter Sink Bolt



(r)  
Qty 1 -  
Joint Sealant



(s)  
Qty 6 -  
M6 x 20mm Hex Bolt

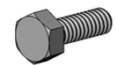

(t)  
Qty 6 -  
M6 Flat Washer



(u)  
Qty 6 -  
M6 Lock Washer



### **Step 1 For Ram Promaster City**

Install "Mount Rail" as shown using M6x20mm bolts (s) with lock washers(u) and flat washers(t). Be sure to put rubber washer(f) between the "Mounting Rail" and the roof to insure sealing. (Passenger side shown)

#### **FRONT**

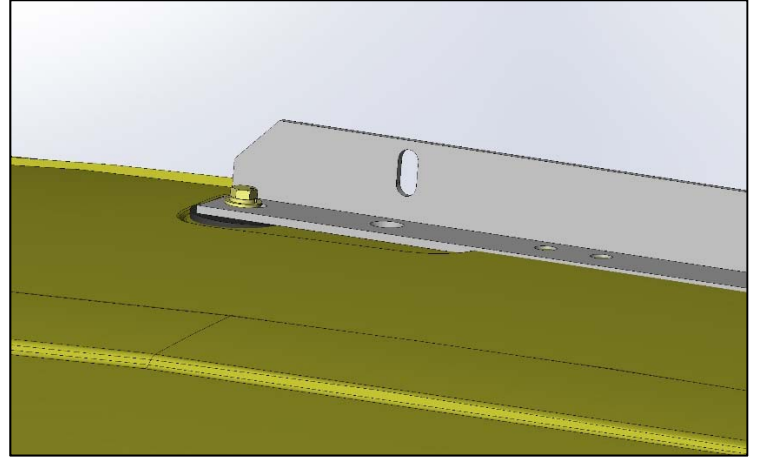
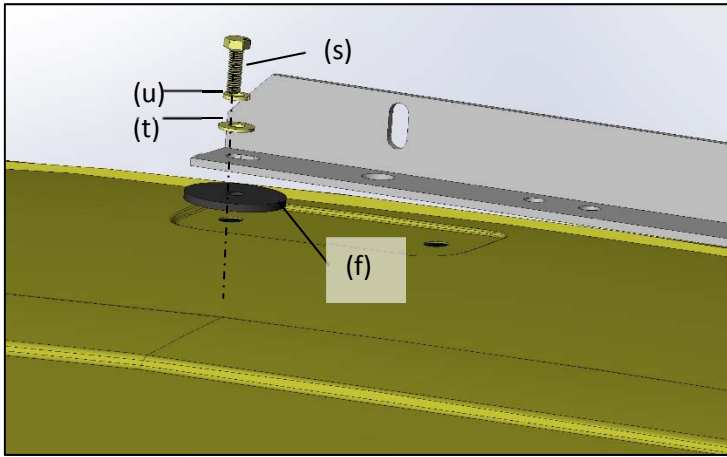

#### **BACK**

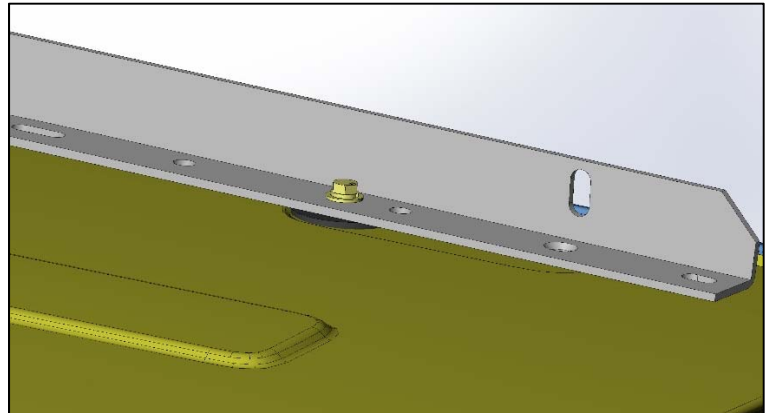
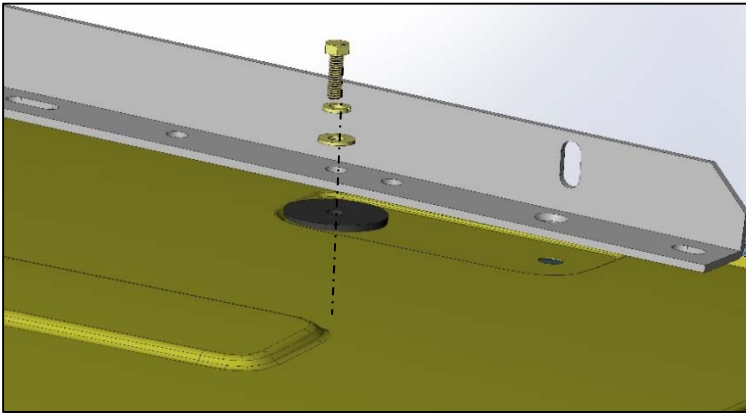

#### **Middle**

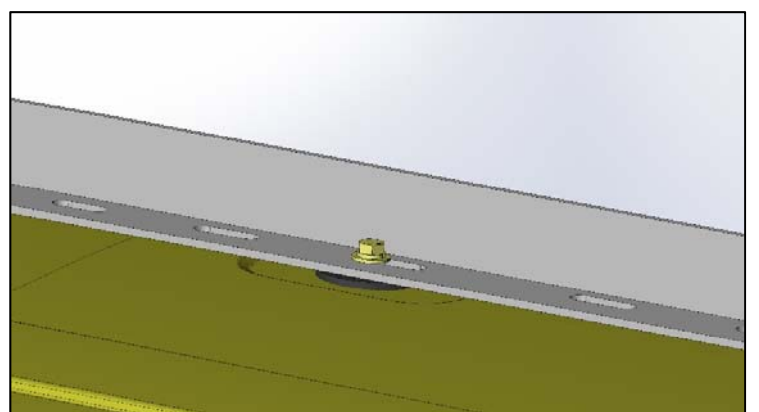
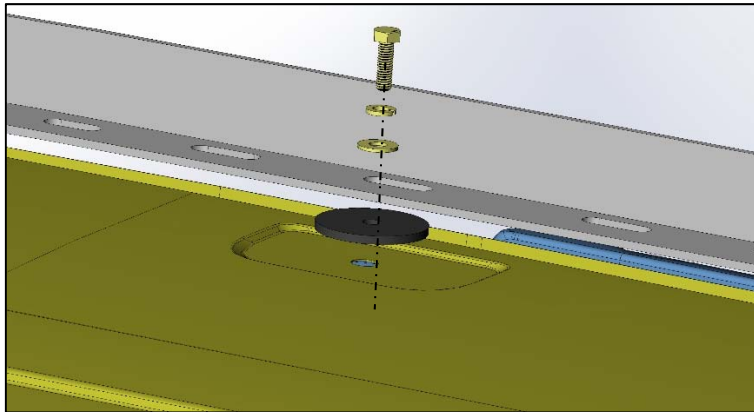

### Step 1 For NV200/Chevy City Express/2014 Transit Connect

Mount rail to roof using M8x25 Bolts (p) with flat washer (b) and lock washers(c) (on 2014 and newer Transit Connect use nyloc nut with fender washer and rubber washer on the underside-Do not use lock washer). Mount rail so that the end of the rail is approximately 1" (usually the 2<sup>nd</sup> or 3<sup>rd</sup> hole-Use countersunk hole for 2013 and older Transit Connect) from where the rear door opening is.

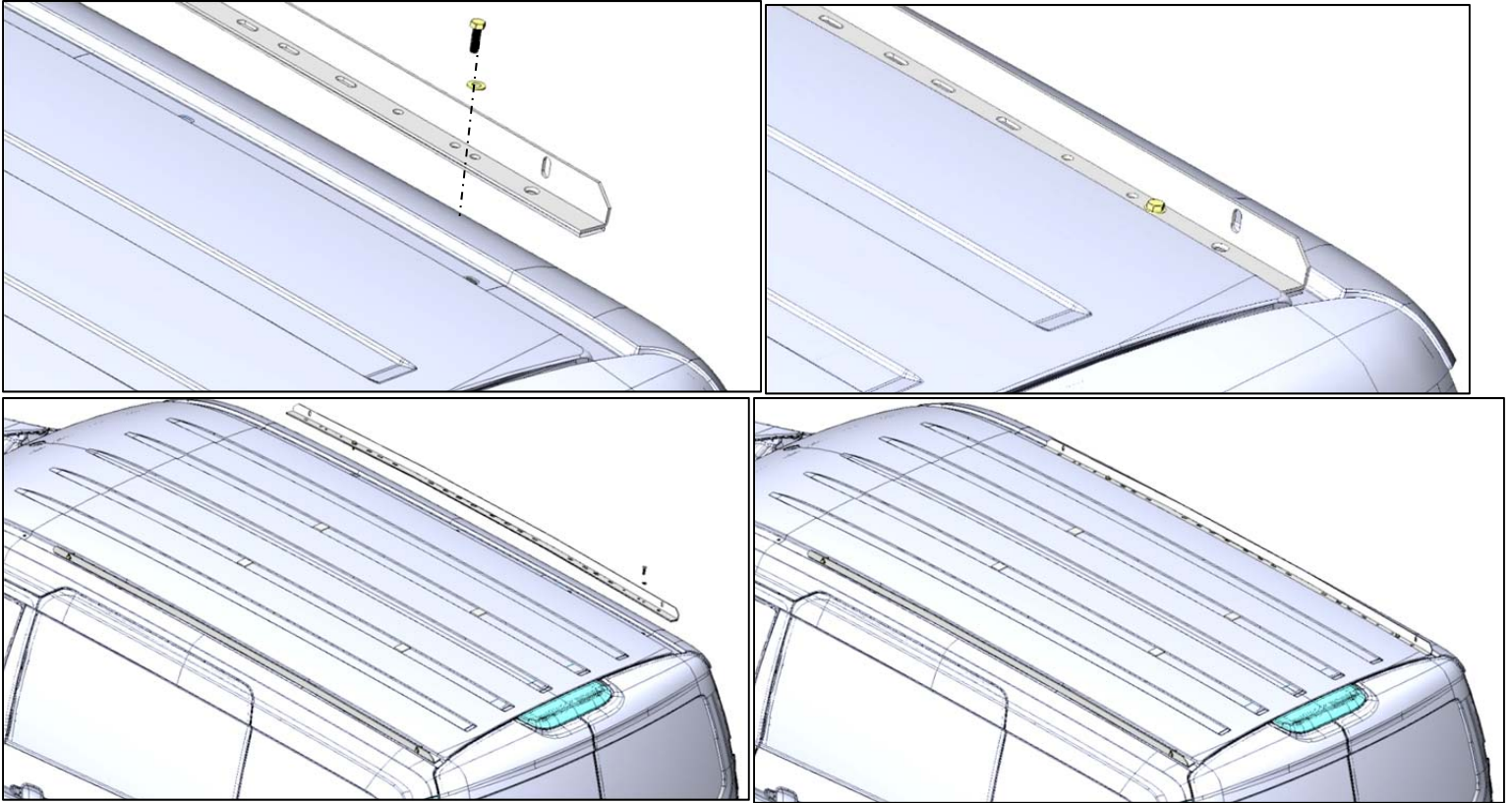

### Step 2

Measure width the rail and bolt feet to bows at that approximate location as shown, DO NOT TIGHTEN at this point.

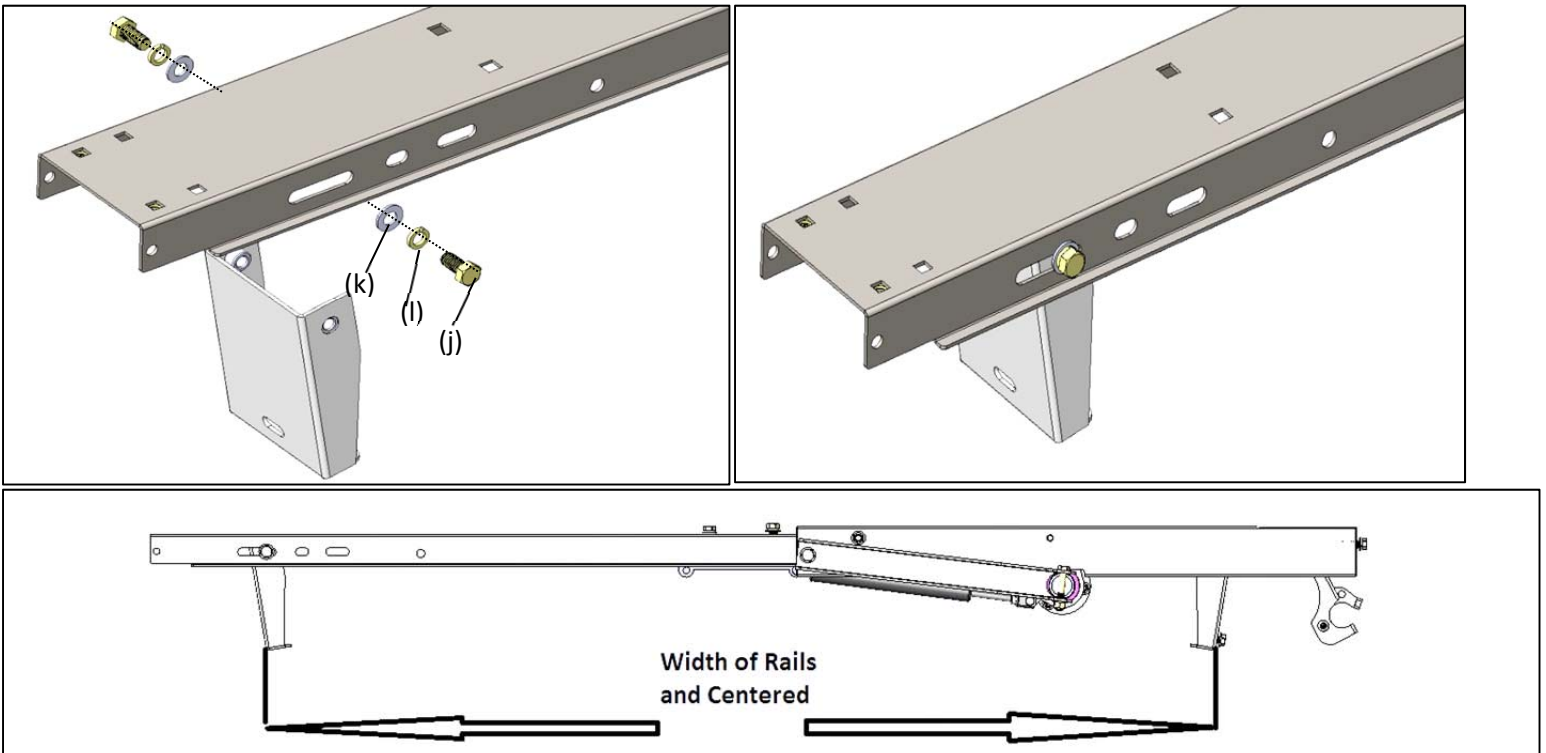

### **Step 3**

Bolt "Latch" as shown using 5/16"x3/4" carriage bolts (a) with flat washers (b) and nyloc nuts (d).

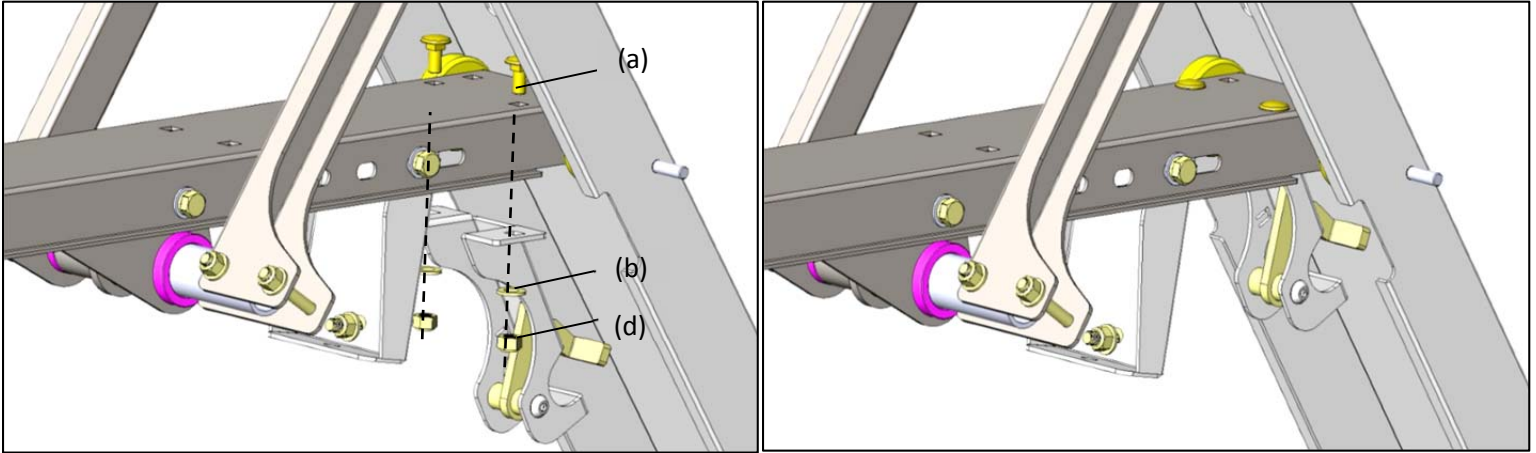

### **Step 4**

Next bolt the Angle bracket on the driver side of the bows using 5/16"x3/4" carriage bolts with nyloc nuts and flat washer as shown.

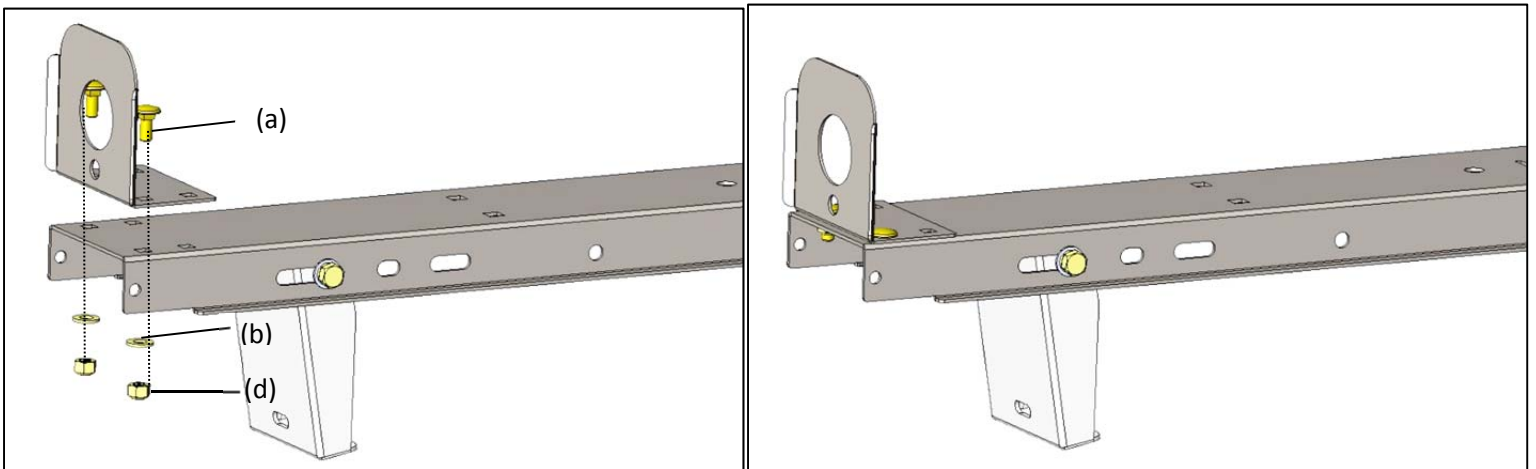

**Step 5**

Place "Rear Bow Assy." as shown and bolt to rails using 5/16"x1" bolts (j) with nyloc nuts(d) and flat washers(b), DO NOT TIGHTEN at this time.

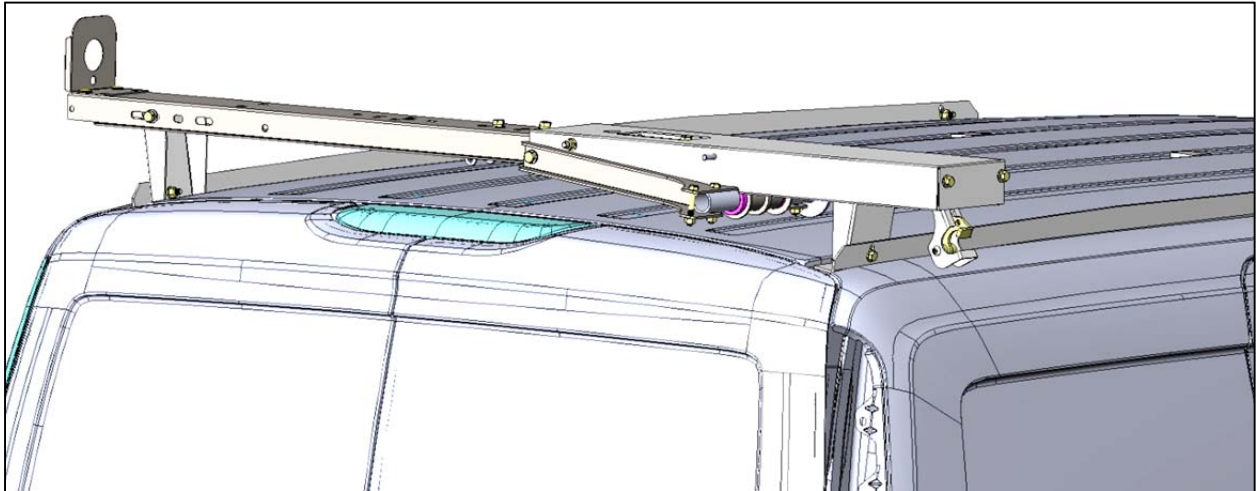
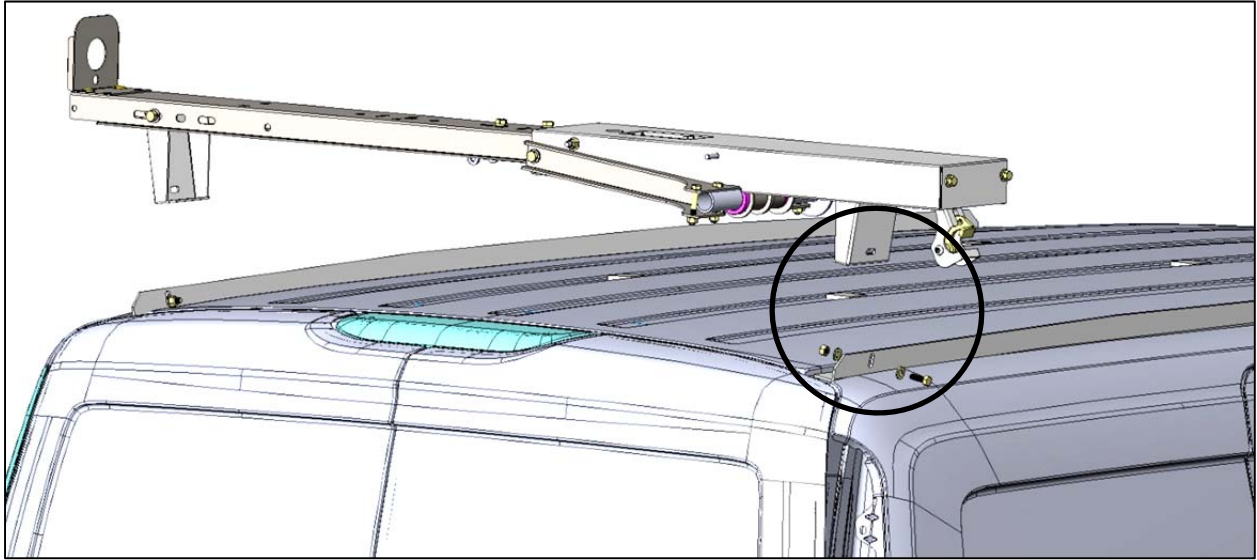



**Step 6**

Place "Front Bow Assy." as shown and bolt to rails using 5/16"x1" bolts(i) with nyloc nuts(d) and flat washers(b), DO NOT TIGHTEN at this time.

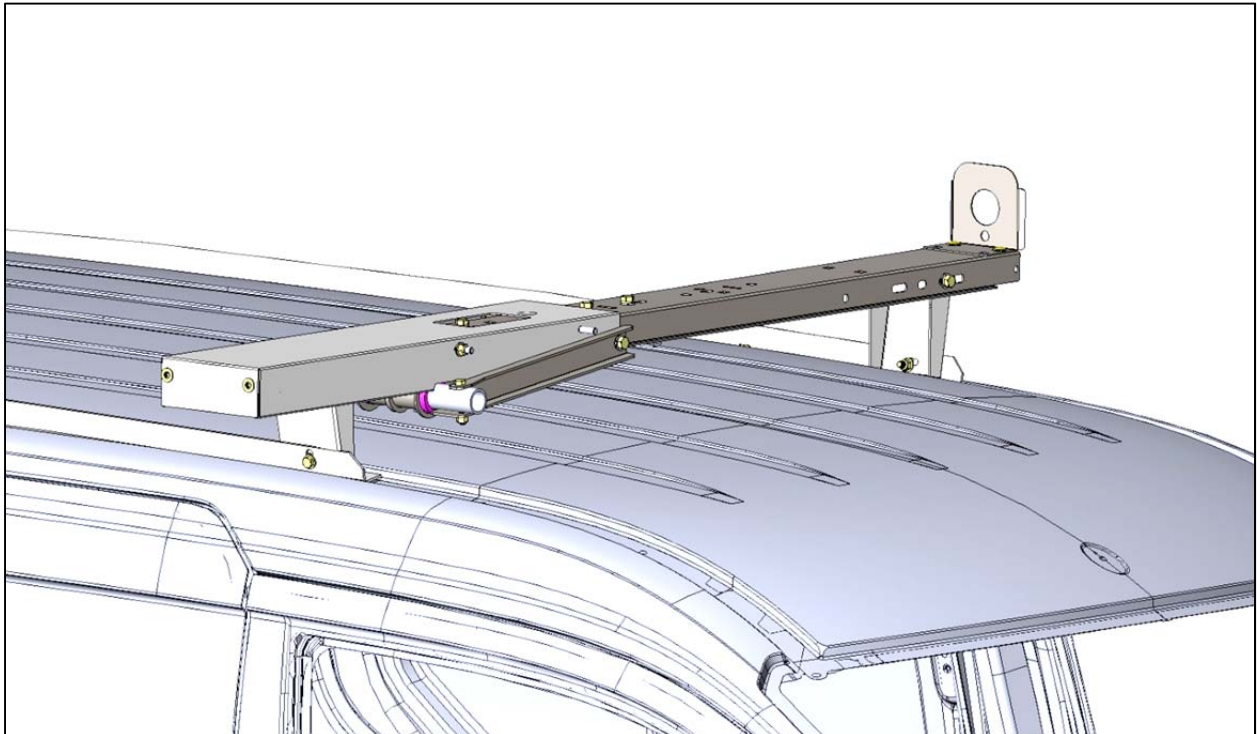
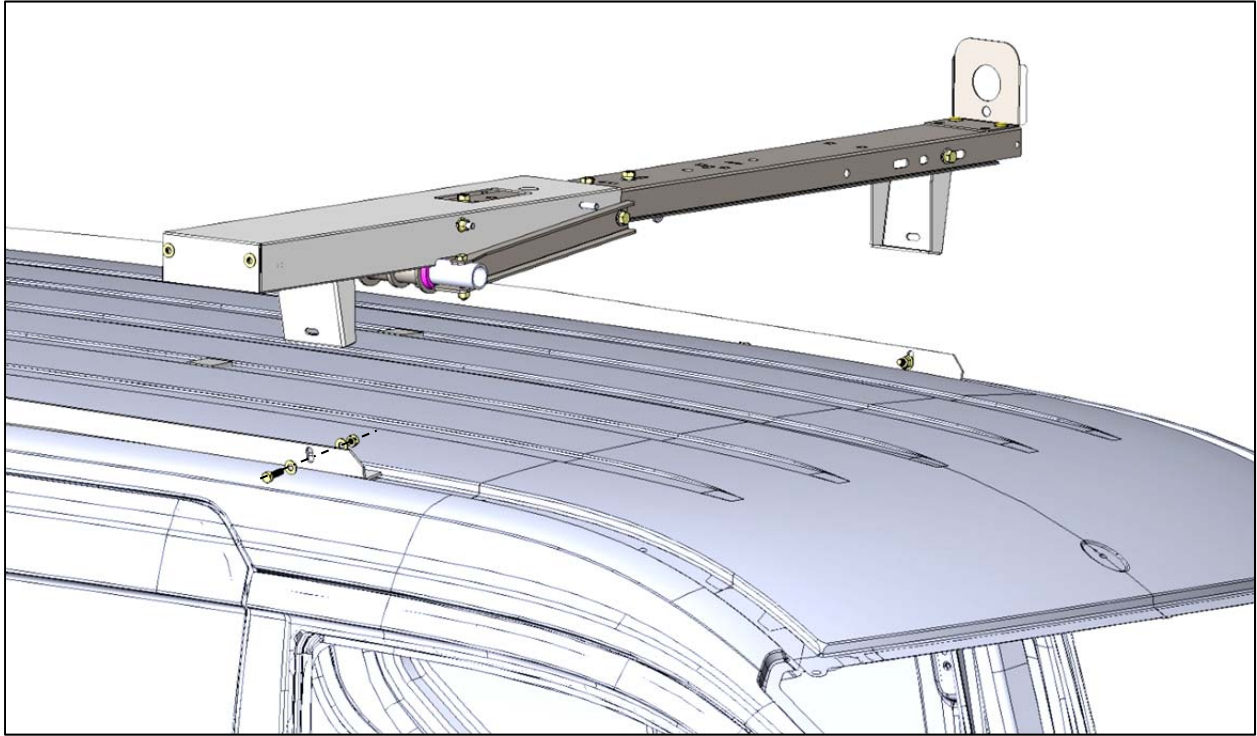

**Step 7**

Bolt the "Torque Tube" using 1/4" x 7/8" bolts(m) with flat washer(n)s and nylock nuts(o). This sets the distance between the front and rear assembly (71.5" center to center), be sure both sides measure the same to ensure proper operation.

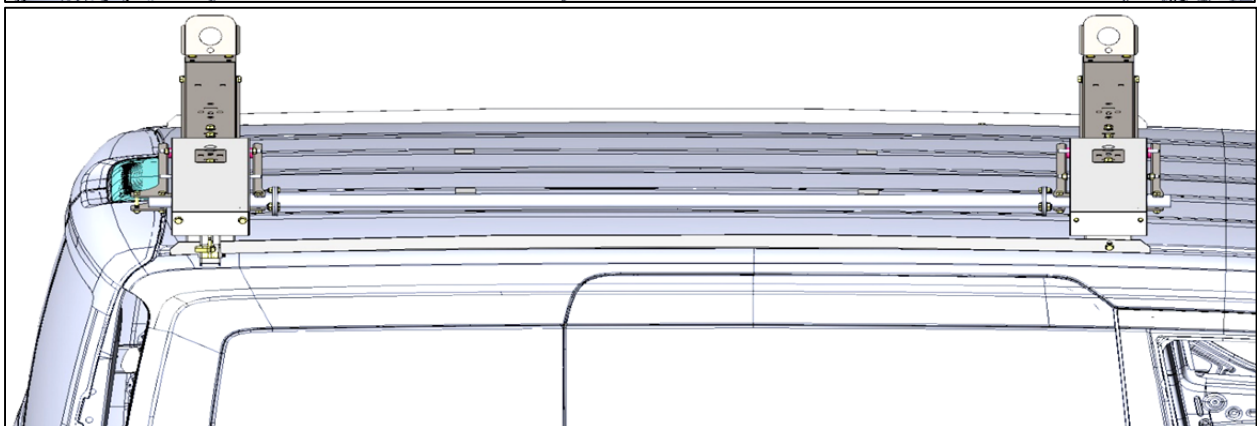
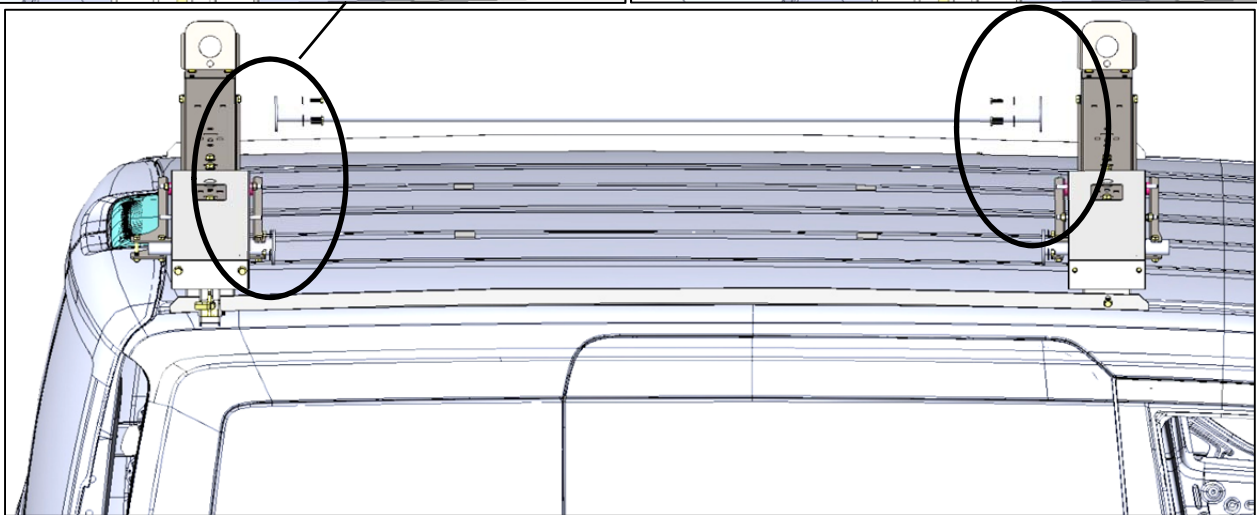
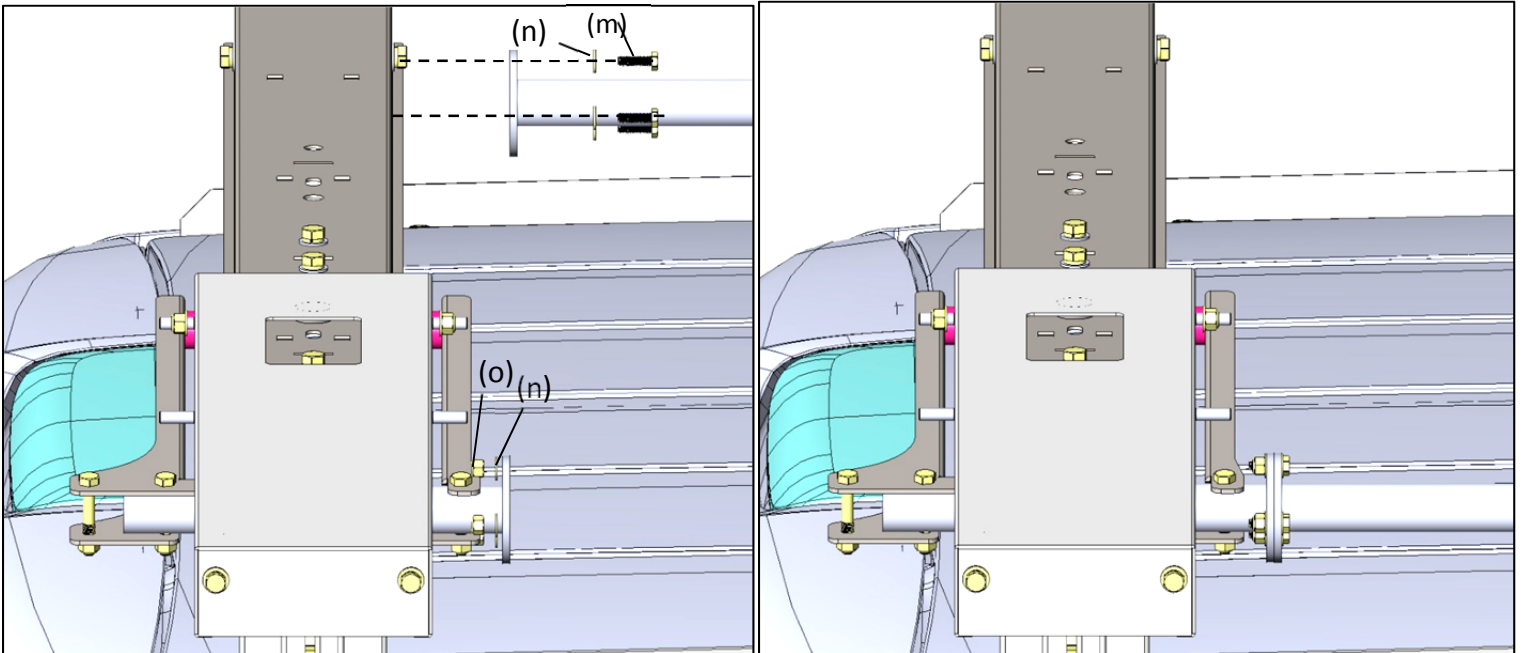

## **Step 8**

Next bolt the "Handle Assy." Using 5/16"x2" bolts with a nyloc nut and flat washers as shown. BE SURE HANDLE WILL CLEAR THE REAR DOORS during operation. If it doesn't clear then the rails need to be mounted back farther on the van.

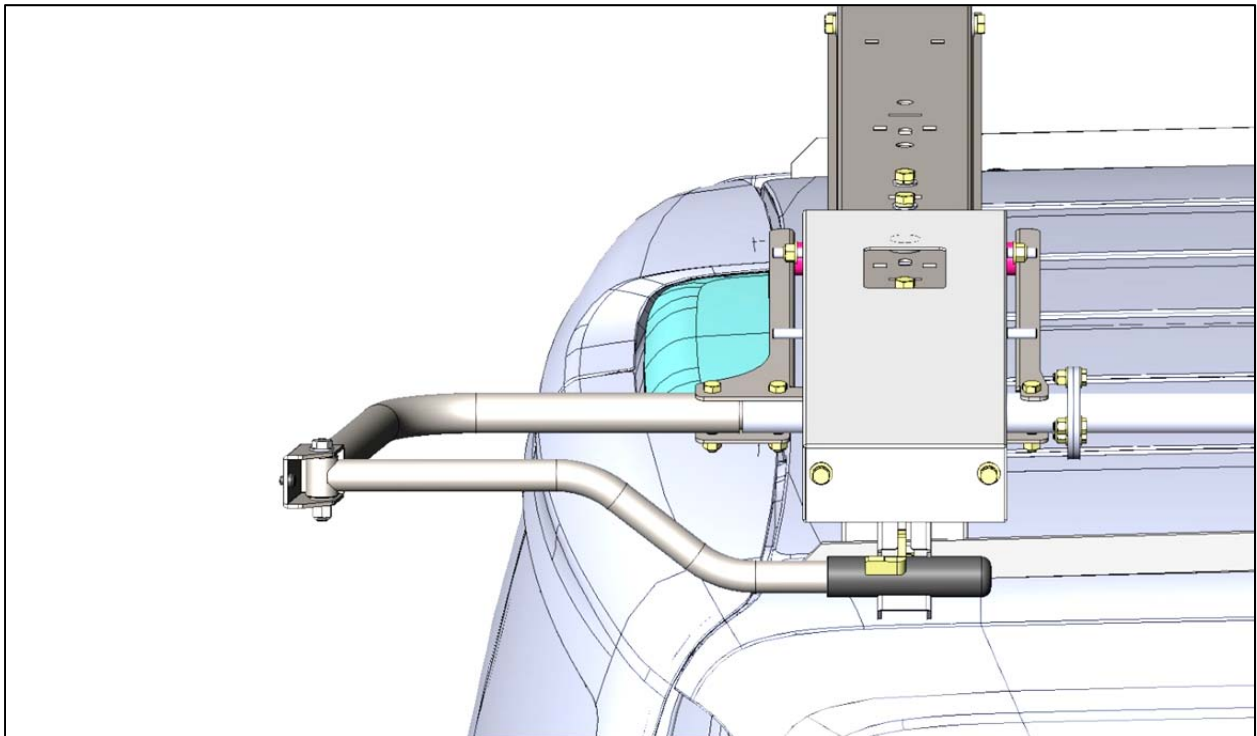
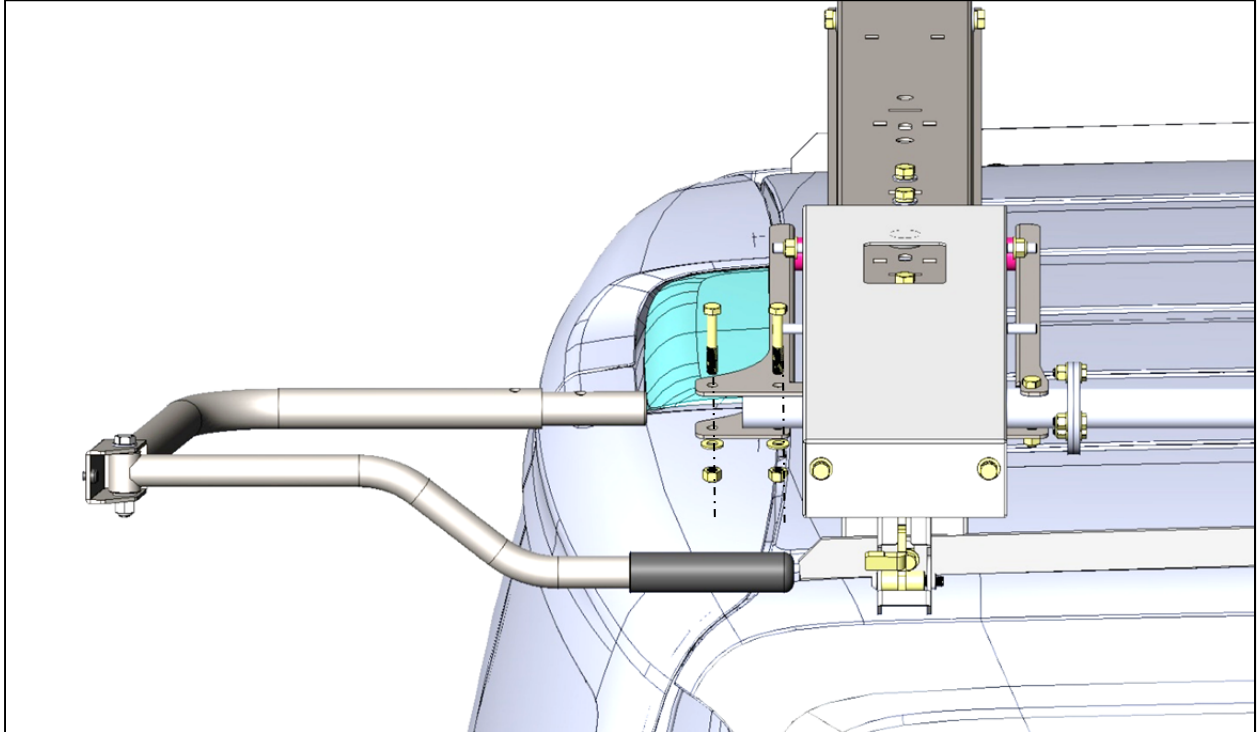

## Step 9

Next attach the “Ladder Pan Stiffener” using 5/16”x5/8” bolts(e) with lock washer(c) and flat washers(b) as shown. With that completed you can now go back and tighten the feet to the rails and then the feet to the front and rear bow assemblies, double check the center to center dimension before tightening (71.5”).

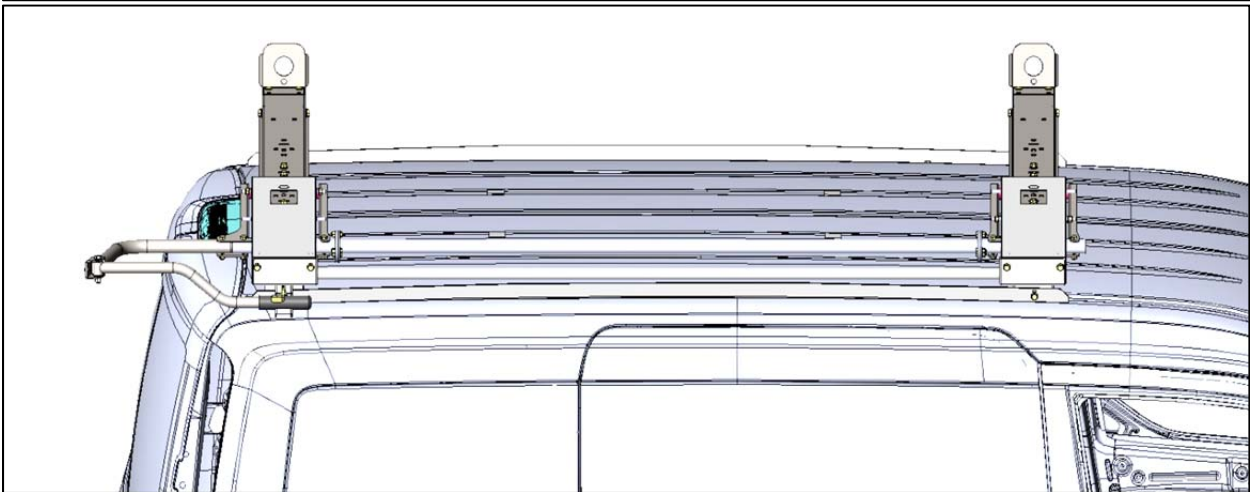
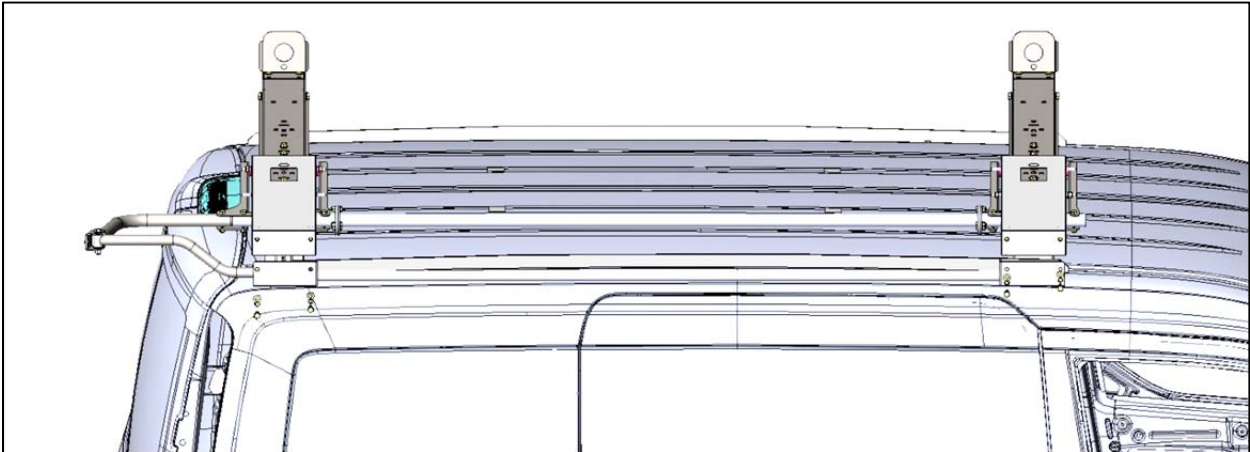
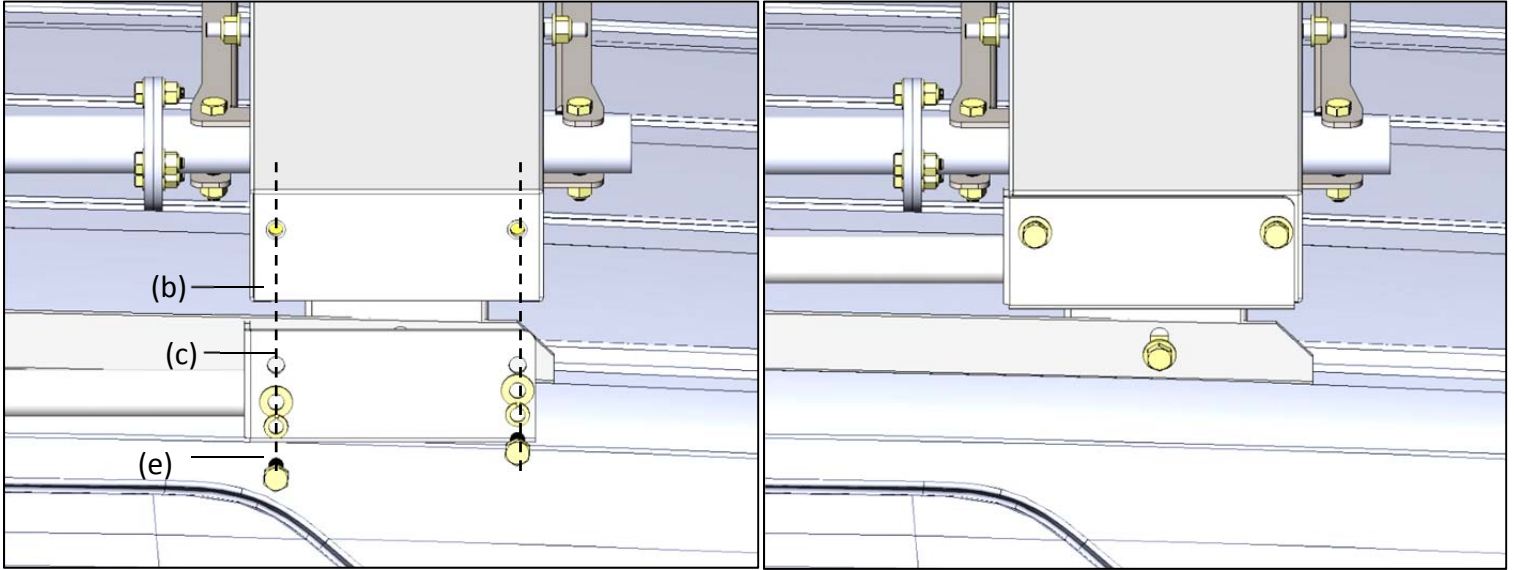

**Step 10**

Next attach the "Ladder Hooks" and "Ladder Stops". The first 4 pictures show the front hooks, the next 4 show the rear hook set in the "step ladder" location. If you are using an extension ladder use the same location as the front bow.

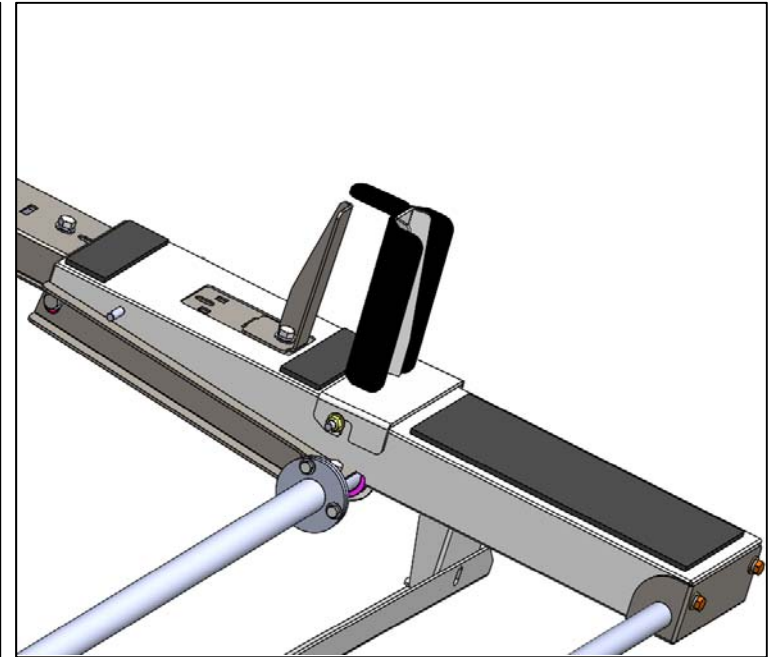
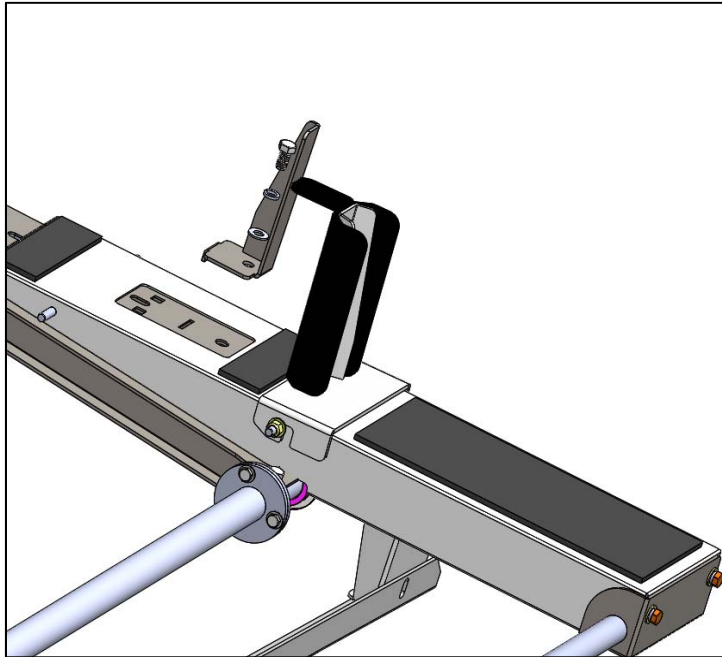
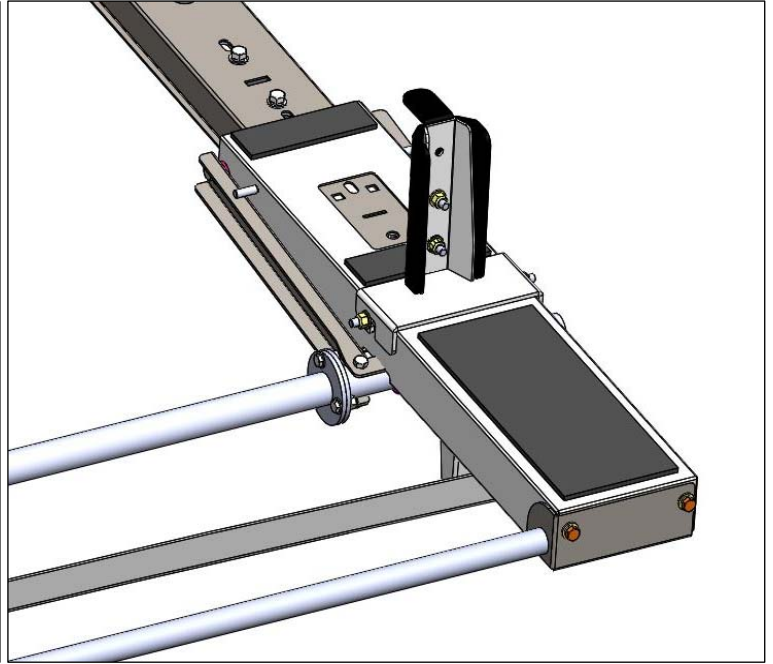
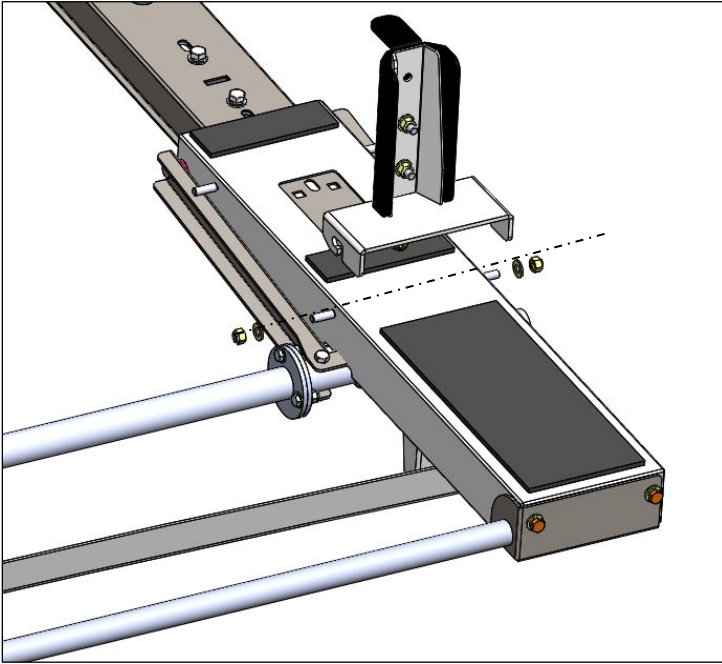

Rear bow location for step ladder.

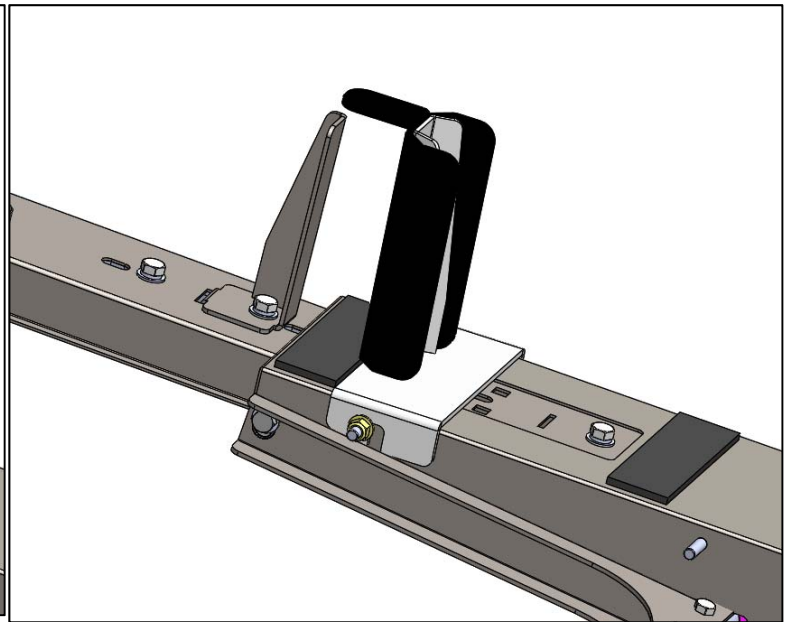
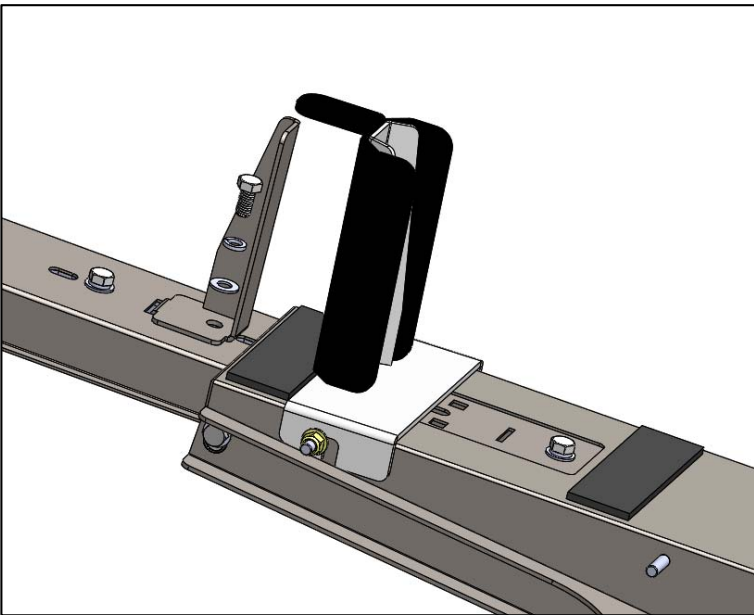
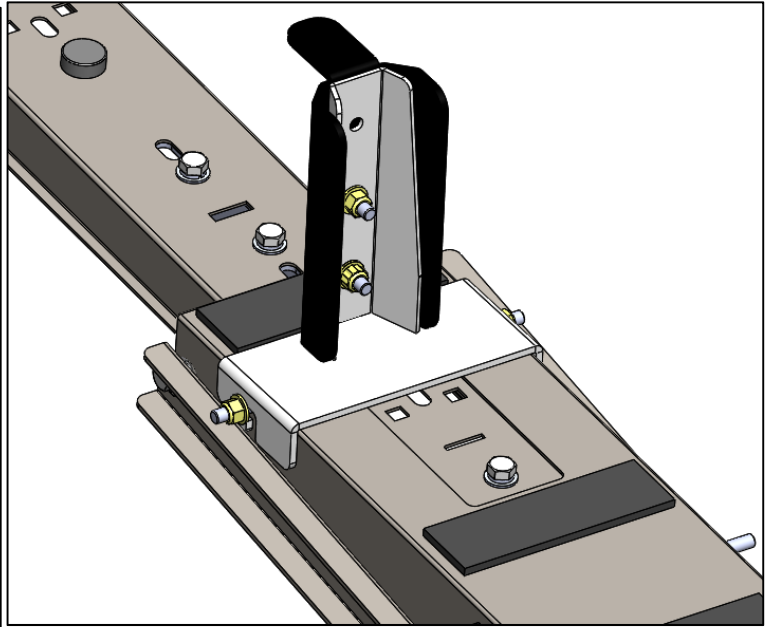
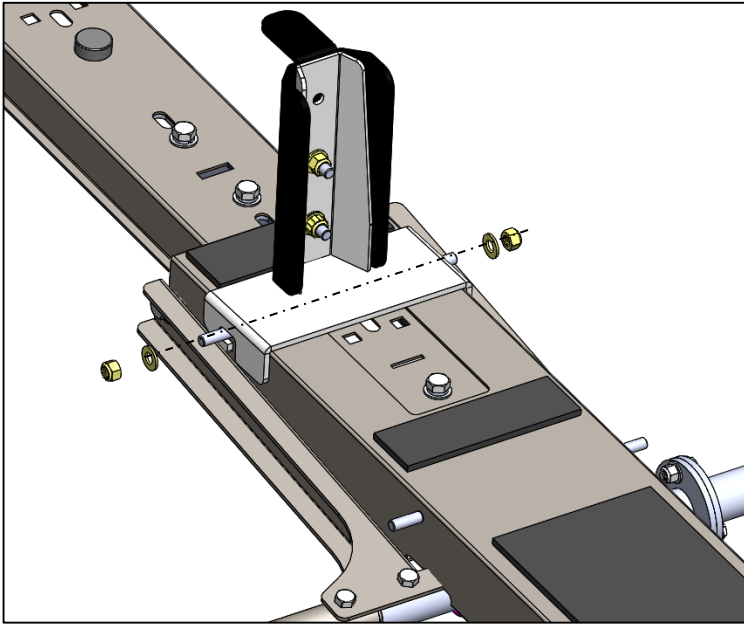

Installation complete for “step ladder”.

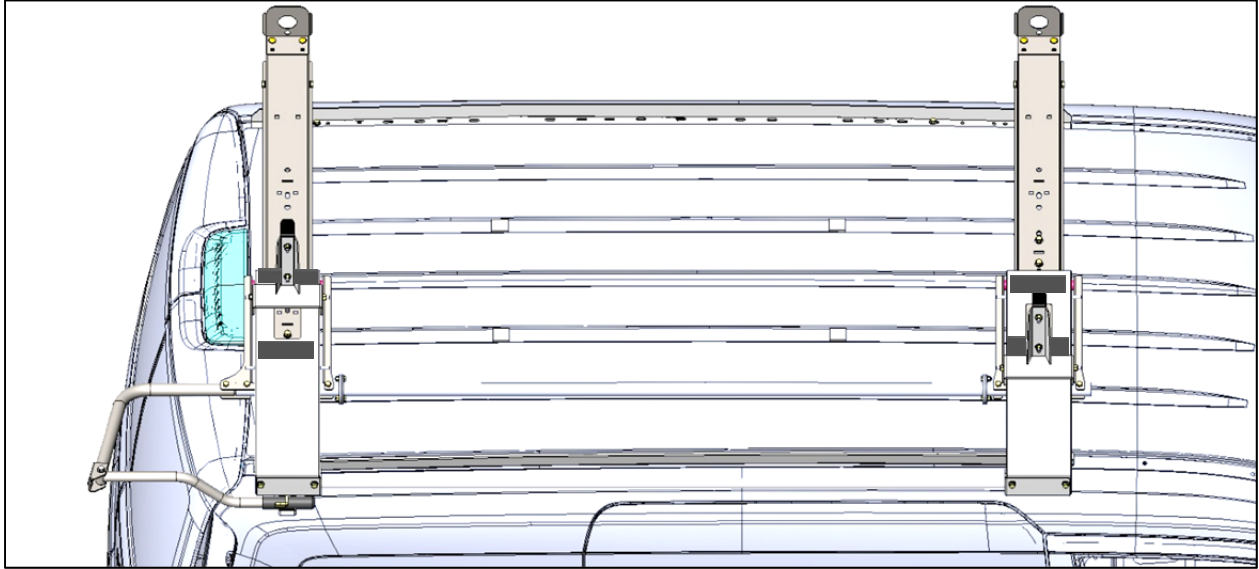

Installation complete for “extension ladder”.

