

---

# KARGO MASTER®

**WE PUT EVERYTHING WITHIN REACH.**

---

## Installation Guide

### 4081S

---

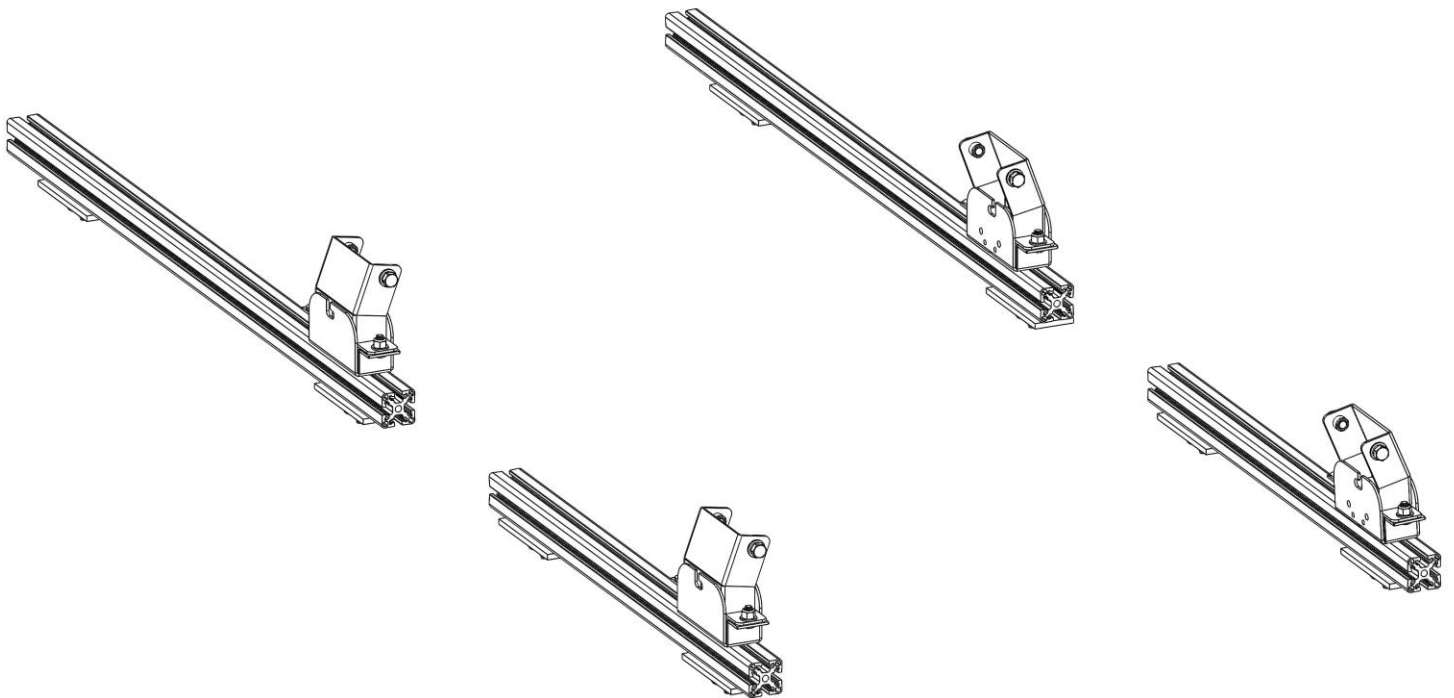

---

**\*PLEASE READ ALL INSTRUCTIONS AND WARNINGS PRIOR TO ASSEMBLING,  
INSTALLING, AND USING THIS PRODUCT\***

---

**Warning**



**Always check for wires, fuel tanks and lines, brake lines and other important vehicle functionality items prior to drilling and installing all products.**

---

**Tools Needed**



1/2" Socket and Wrench	9/16" Socket and Wrench
1/2" Box Wrench	Tape Measure

---

**Before You Begin**

- Read all instructions prior to installing any Kargo Master product.
  - **Be sure to put sealant around all threads entering cargo area and between the rubber spacer and roof of vehicle to prevent water from leaking into cargo area.**
  - Follow rack assembly instructions to assemble rack.
-

**Sprinter Mount Parts**

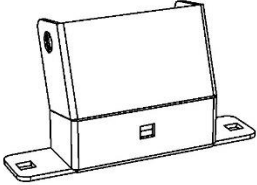
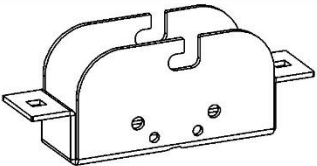
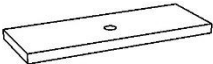
ITEM NO.	ITEM	PART NUMBER	DESCRIPTION	QTY
1		40818-S-002	SPRINTER RAIL LONG	2
2		40818-S-003	SPRINTER RAIL, SHORT	2
3		100862	SPRINTER HR FOOT	4
4		40818-20-003-R1	RAISED FOOT BRACKET	4
5		40818-10-003-R1	TRANSIT AND SPRINTER RUBBER PAD	8
6		18-40818-S	SPRINTER BOLT KIT	
7		18-40818-FT	FOOT BOLT KIT	

**Hardware 18-40818-S**

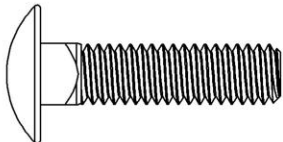
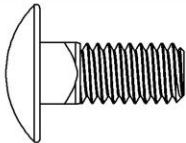
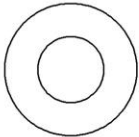
ITEM	HARDWARE TO SCALE	PART NUMBER	DESCRIPTION	QTY.
1		11137256	5/16"-18 X 1-1/4" CARRIAGE BOLT	8
4		21810	5/16"-18 X 3/4" CARRIAGE BOLT	8
3		11545144	5/16" FLAT WASHER	8

**Hardware 18-40818-S (Continued)**

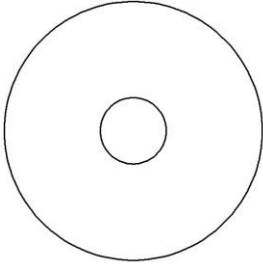
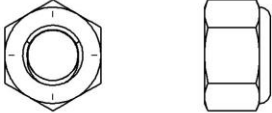
ITEM	HARDWARE TO SCALE	PART NUMBER	DESCRIPTION	QTY.
4		33216	5/16" FENDER WASHER	8
5		0169777	5/16"-18 LOCK NUT	16

**Mounting Hardware 18-40818-FT**

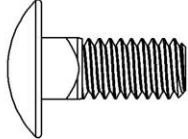
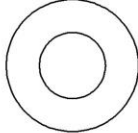
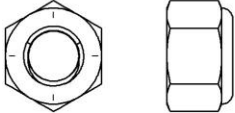
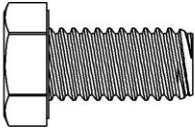
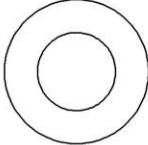
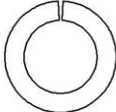
ITEM	HARDWARE TO SCALE	PART NUMBER	DESCRIPTION	QTY.
1		21810	5/16"-18 X 3/4" CARRIAGE BOLT	16
2		33080	5/16" WASHER	16
3		0169777	5/16"-18 LOCK NUT	16
4		11241196	3/8"-16 X 3/4" HEX HEAD BOLT	8
5		11541089	3/8" WASHER	8
6		0123496	3/8" SPLIT LOCK WASHER	8

## Step 1 – Prepare Extrusion

- Slide two 5/16" x 1-1/4" carriage bolts into each rail piece.

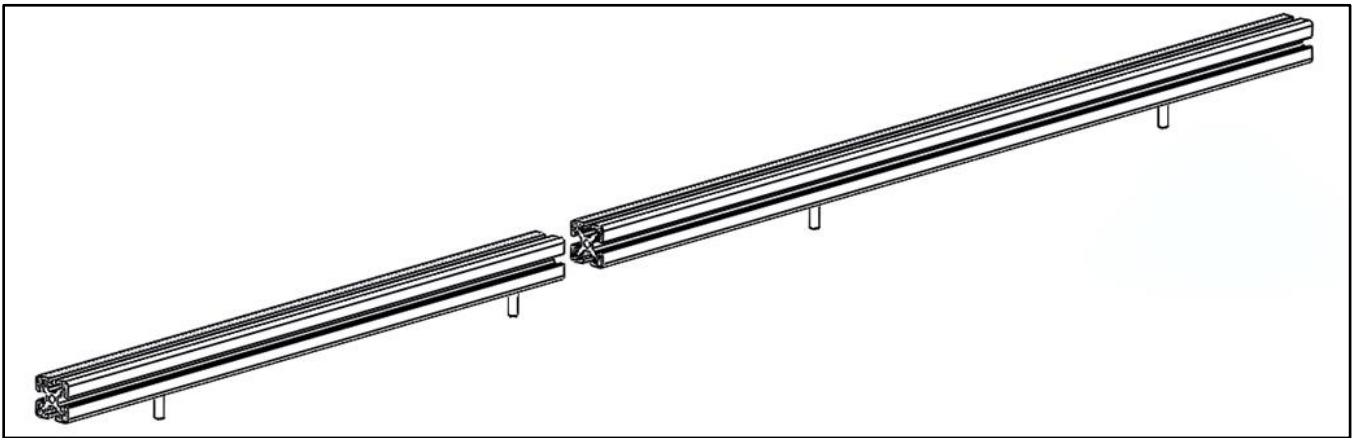
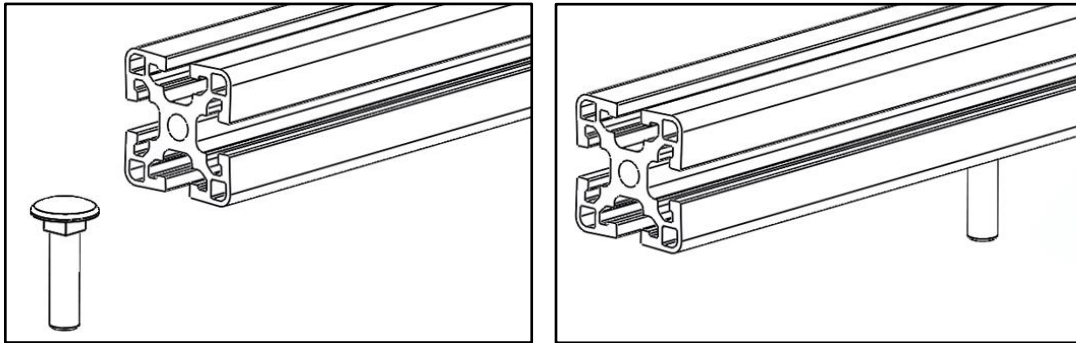

## Step 2 – Locate Mount Holes

- Locate the two rear most factory bosses and drill out using a 5/16" drill bit, about 16-15/16" apart.
- Skip the next two bosses, then drill the forward two (at about 62" and 78.5" from the rear most hole).
- Some roof heights and wheelbases will vary. Your mounting rails should allow the rack to be mounted approximately between 14" to 18" from the rear of the van and have about 40" between mounting rails.

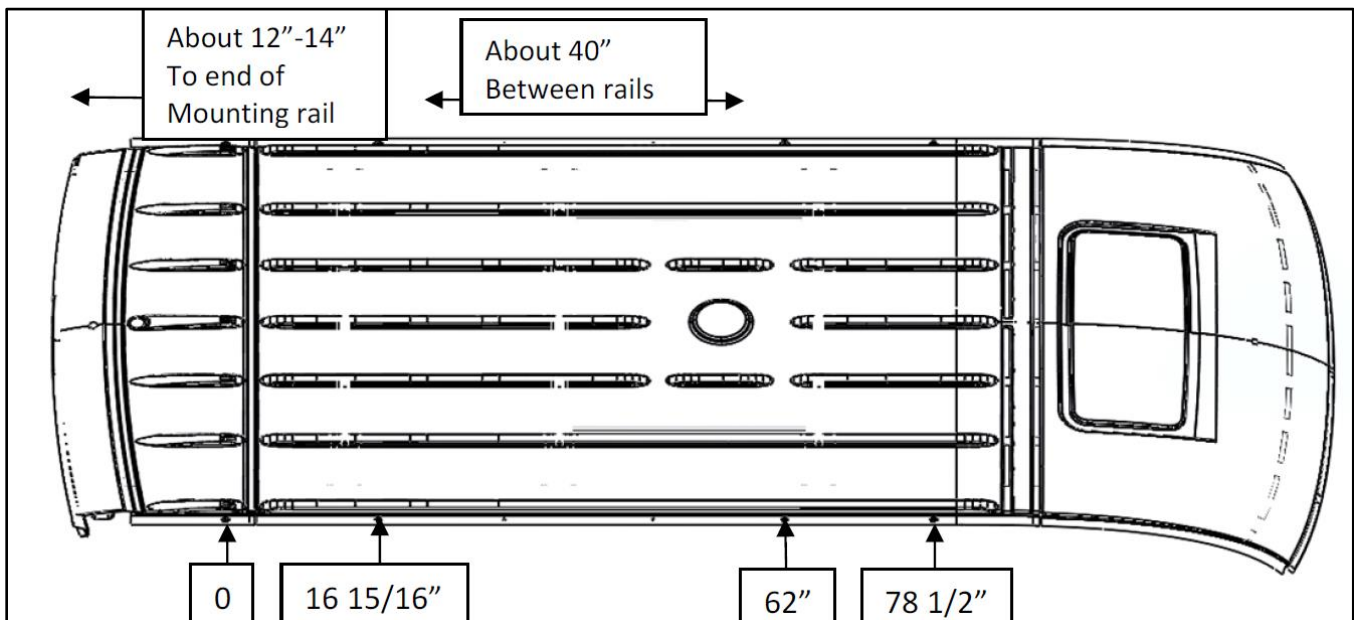

### Step 3 – Attach Mount Rails

- Put rubber pad onto carriage bolts and align them with the holes drilled in previous step.

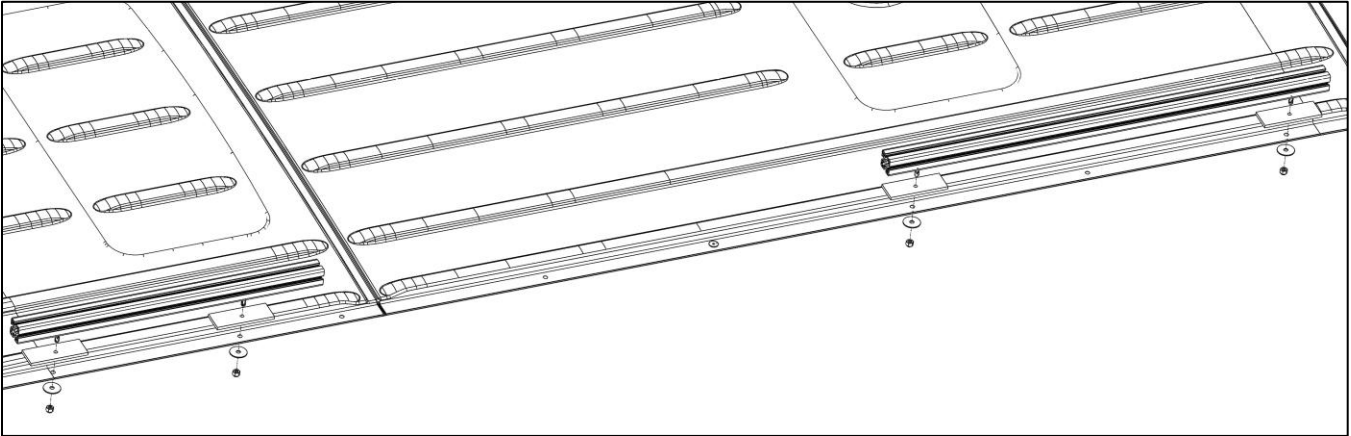

- Place sealant in between rubber pad and the roof.
- The shorter rail goes to the rear of the van with approximately 6" of the rail behind the carriage bolt.

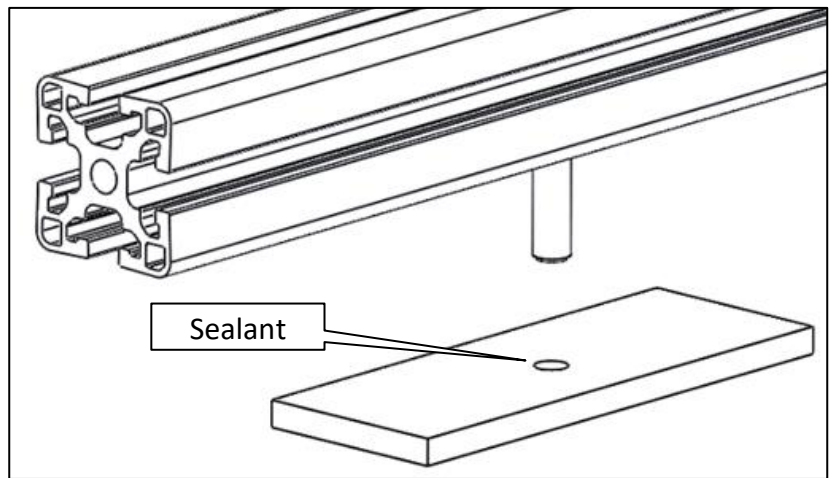

- Bolt through the roof using previously installed carriage bolts, 5/16" fender washers and 5/16" lock nuts.
- Be sure to put sealant around the hole in the roof to ensure no water leaks into van.

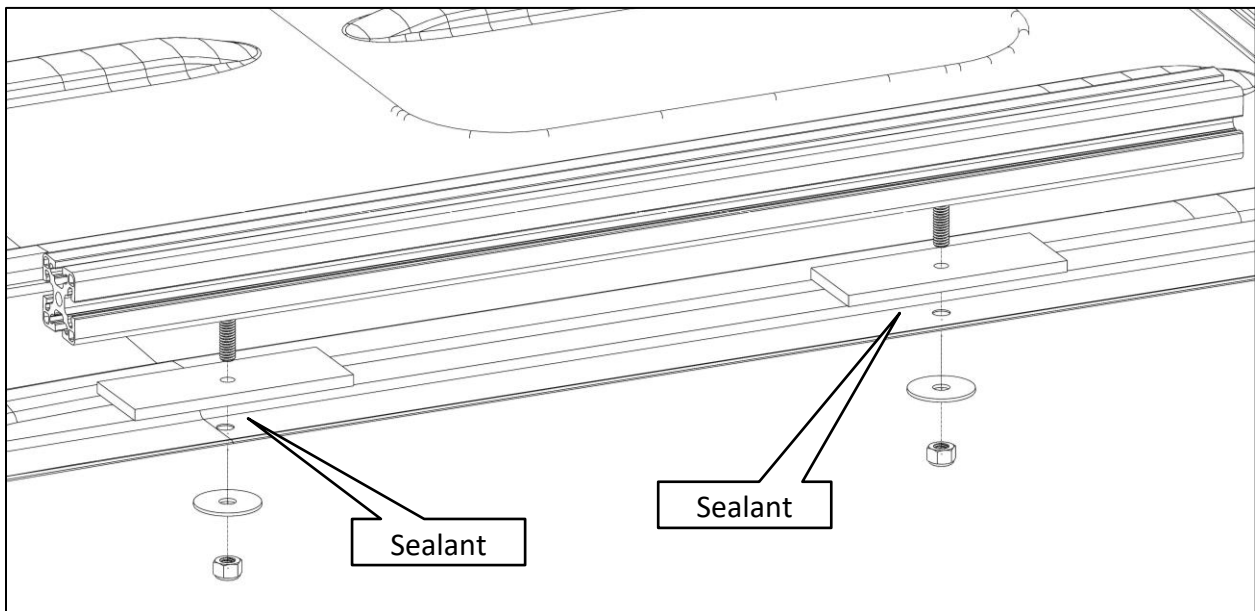



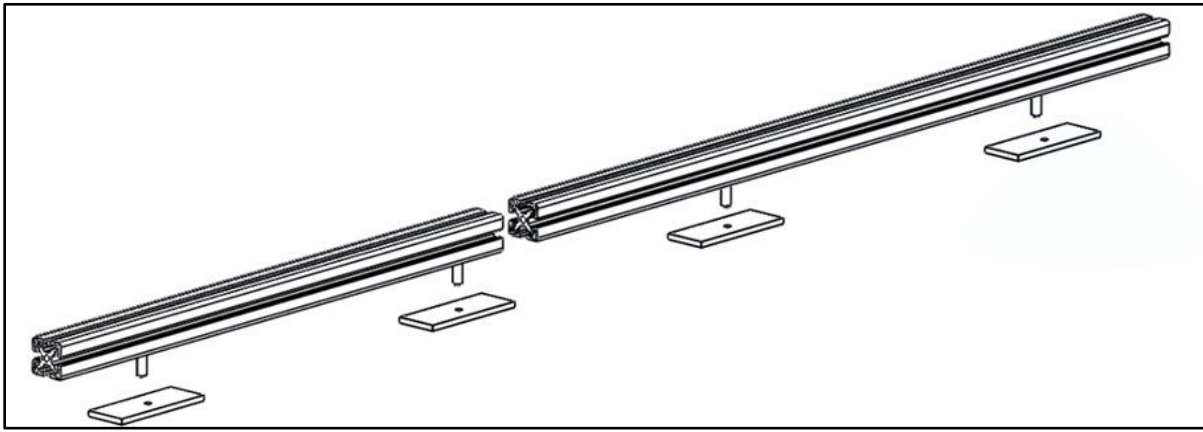

**\*\*PICTURE SHOWN ABOVE DOES NOT ACCURATELY SHOW SPACING BETWEEN RAILS\*\***

- Place longer rail on roof, towards front of van, with carriage bolts aligned with holes drilled. Keep approximately 40" in between the front and rear rails.
- Place sealant in between rubber pad and the roof.
- Bolt through the roof using previously installed carriage bolts, 5/16" fender washers and 5/16" lock nuts.
- Be sure to put sealant around the hole in the roof to ensure no water leaks into van.
- Snug tighten, but allow movement.
- Repeat this entire step on driver side.

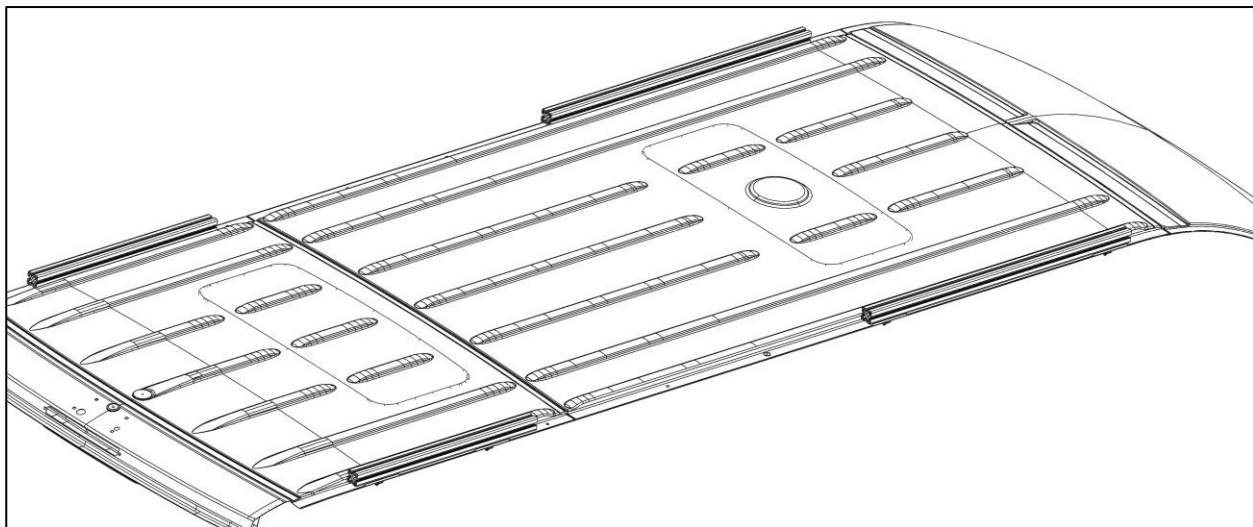
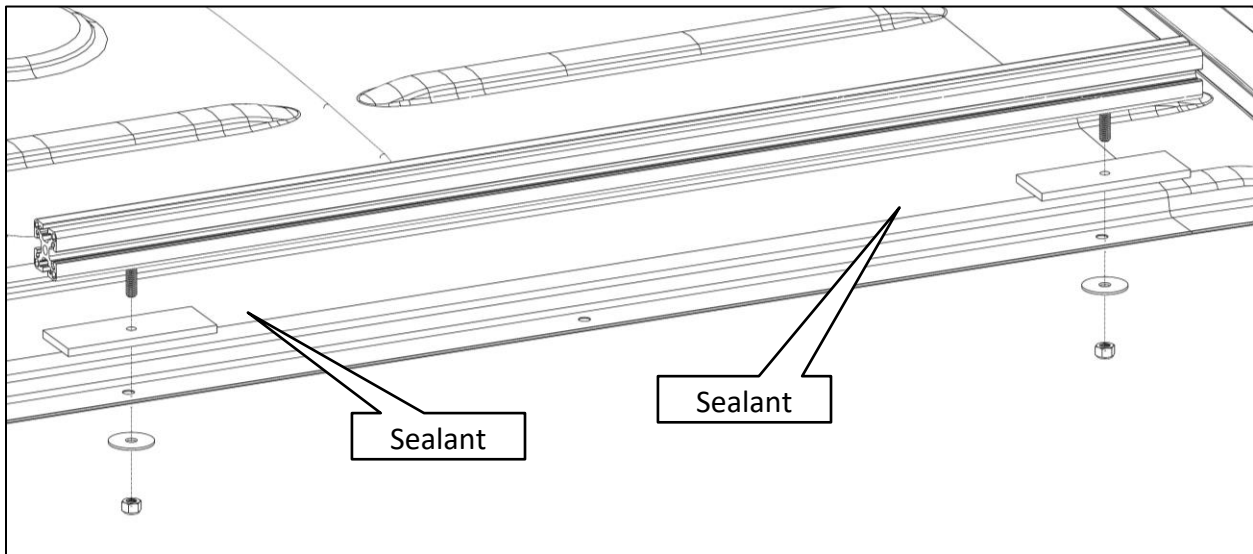

### Step 4 – Attach Mount Block

- Slide two 5/16" x 3/4" carriage bolts into the top slot on each rail piece.
- Place mount block on top of each carriage bolt.
- Bolt together using the carriage bolts, two 5/16" flat washers and two 5/16" lock nuts.

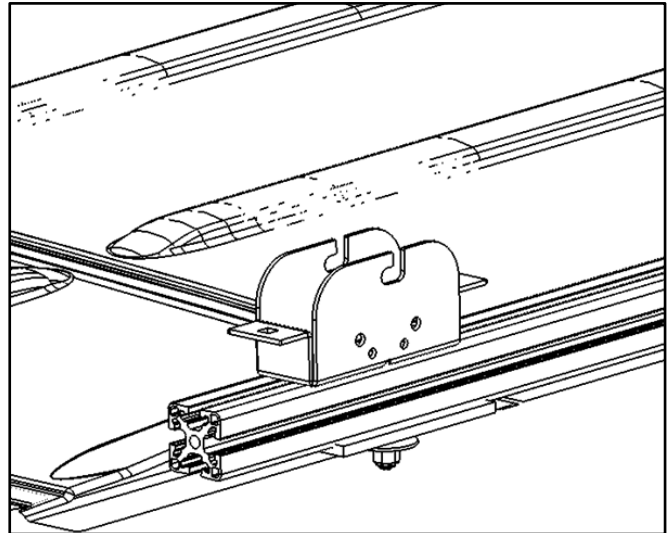
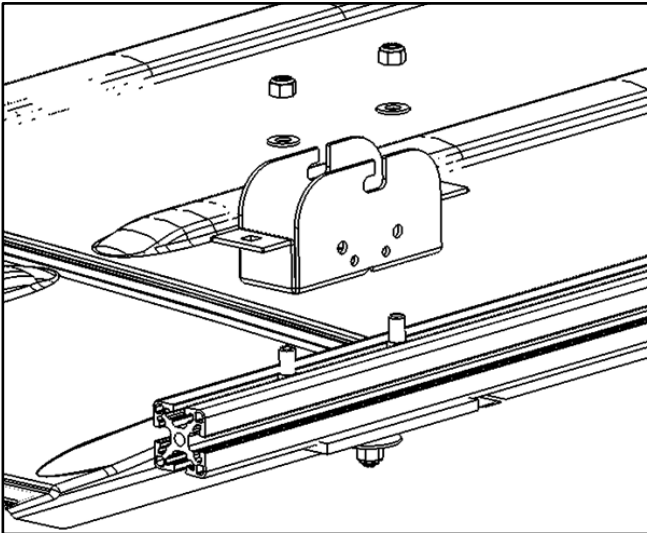

Space mount blocks 71.5" apart for a standard installation.

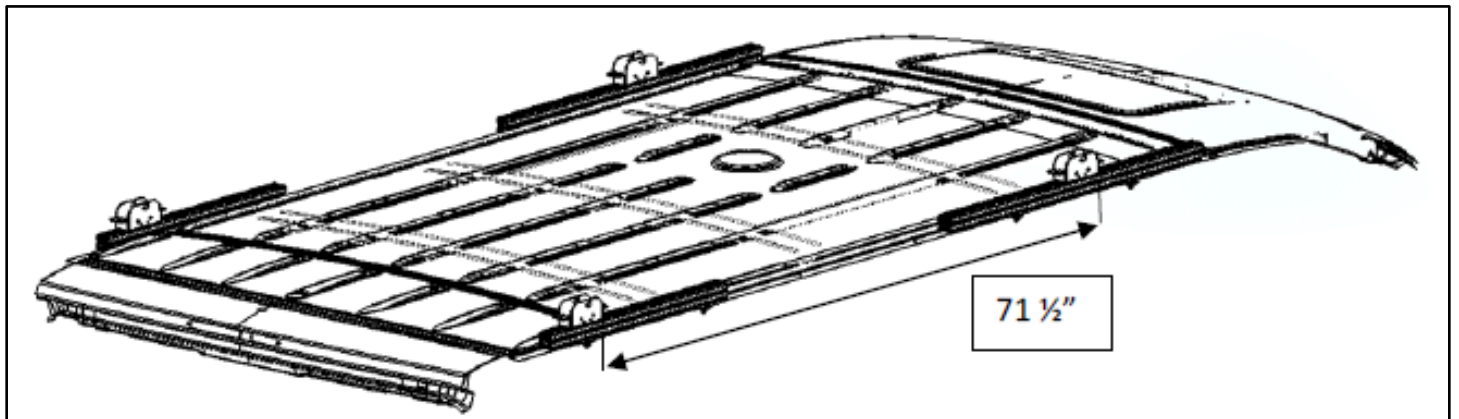

Space mount blocks 96" apart for an extended installation.

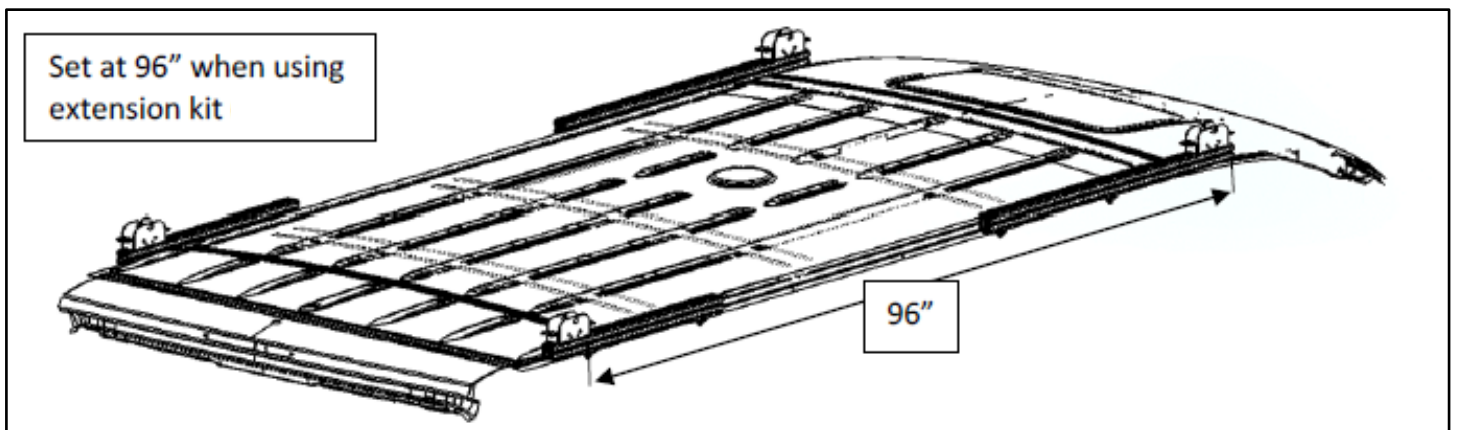

- Snug Tighten, but allow brackets to move.



## Step 5 – Attach Mount Feet

- Mount feet to previously installed mount blocks using two 5/16" x 3/4" carriage bolts, two 5/16" flat washers and two 5/16" lock nuts.
- The carriage bolt can face upward or downward based on preference.
- Repeat for remaining three mount blocks.

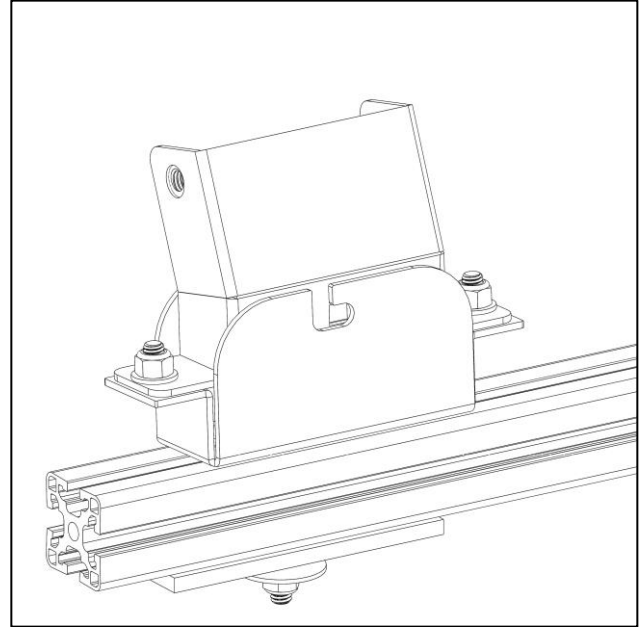
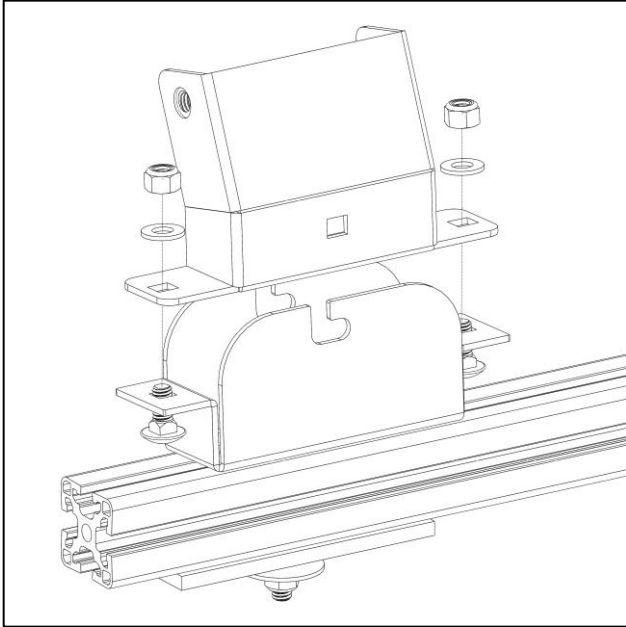

Approximately 71.5" apart.

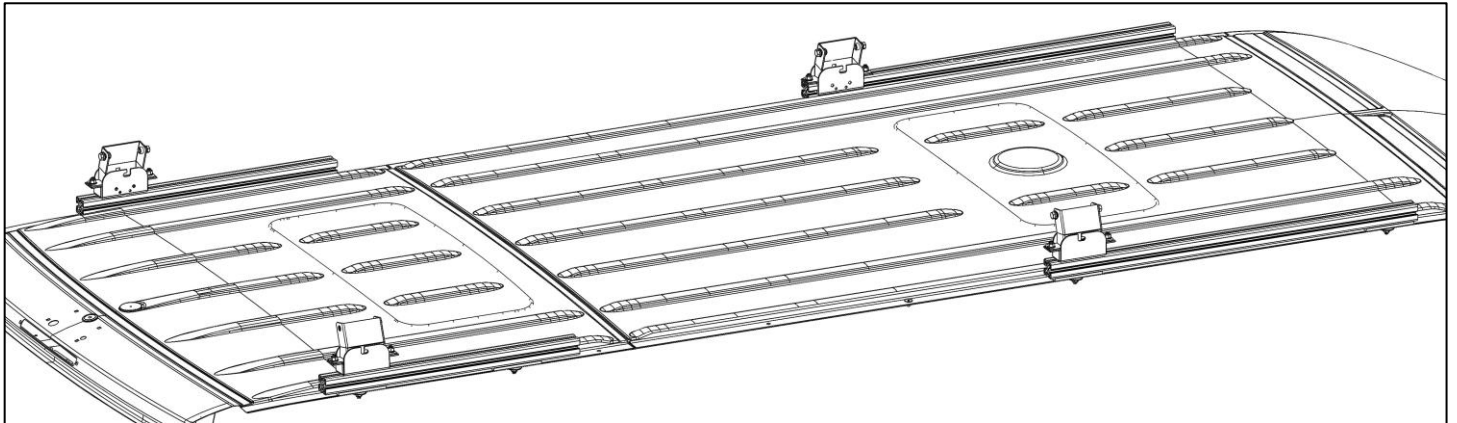

Approximately 96" apart.

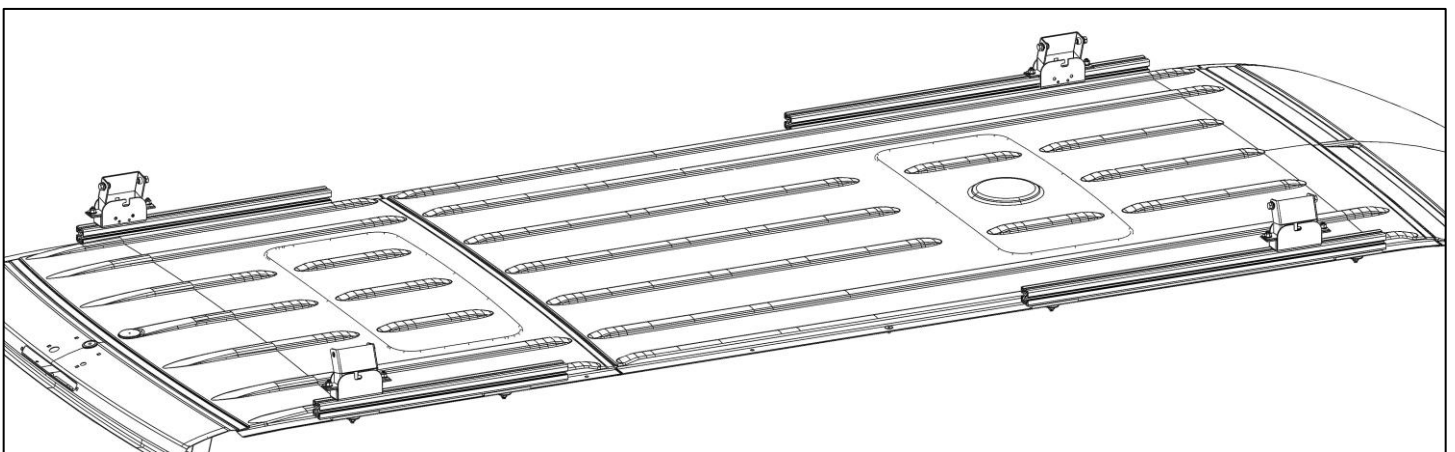

## **Step 6 – Mount Rack to Feet**

- If the rack is being assembled on the vehicle, set rack on top of installed feet, and center rack to vehicle, side to side.
- If the rack will be assembled off the vehicle, measure the distance between the center of the left and right rails. Mount the feet to the rack with the bottom of the mounting feet, at the distance measured and centered to the rack.
- For each foot, bolt the bows to feet using two 3/8" x 3/4" hex head bolts, two 3/8" lock washers, and two 3/8" flat washers.
- Tighten.

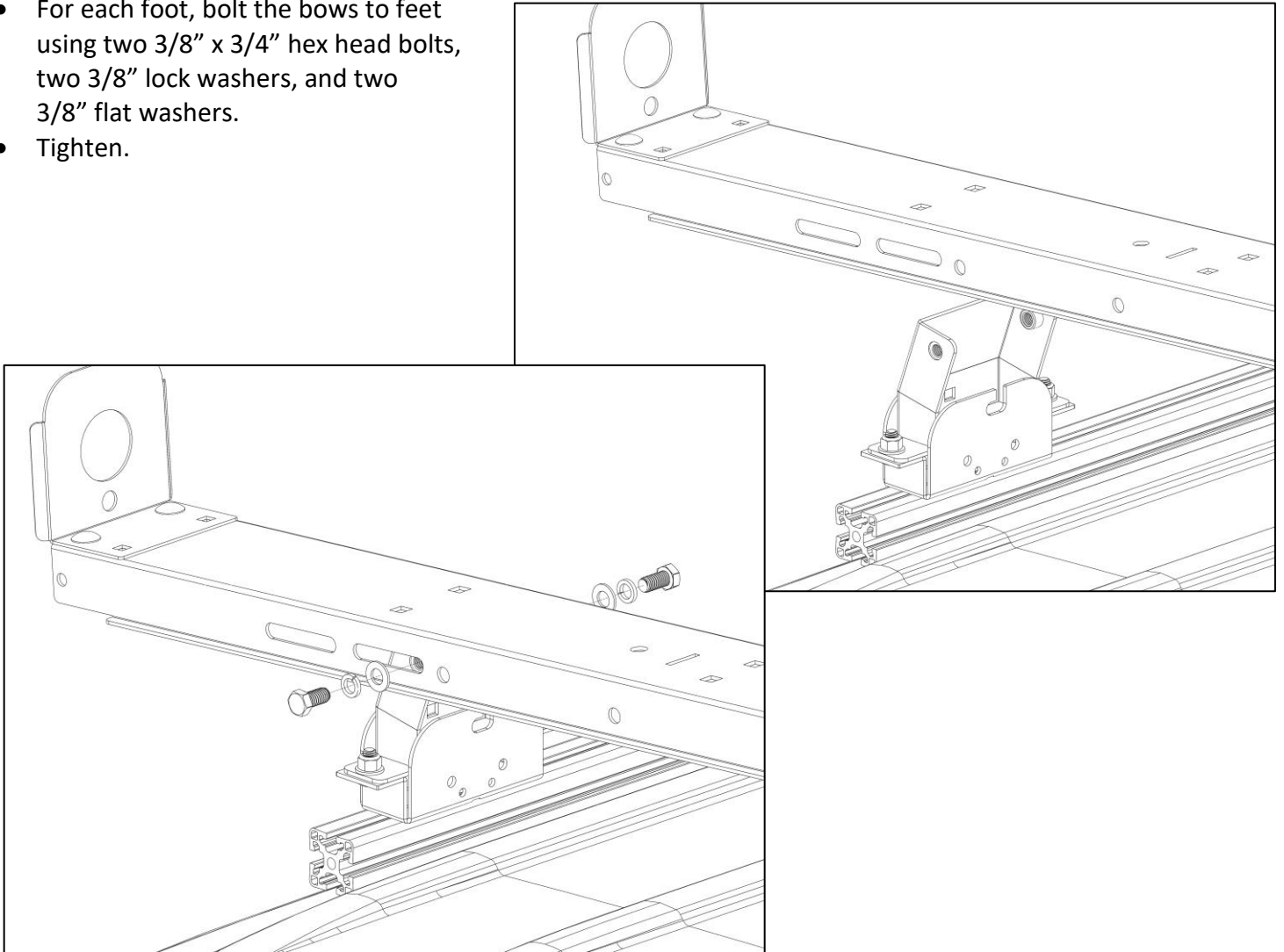

**GO BACK AND ENSURE ALL HARDWARE IS TIGHT.**

**YOUR INSTALLATION IS NOW COMPLETE.**

---

# KARGO MASTER®

WE PUT EVERYTHING WITHIN REACH.

---

## Installation Guide

---

### 4099H

---

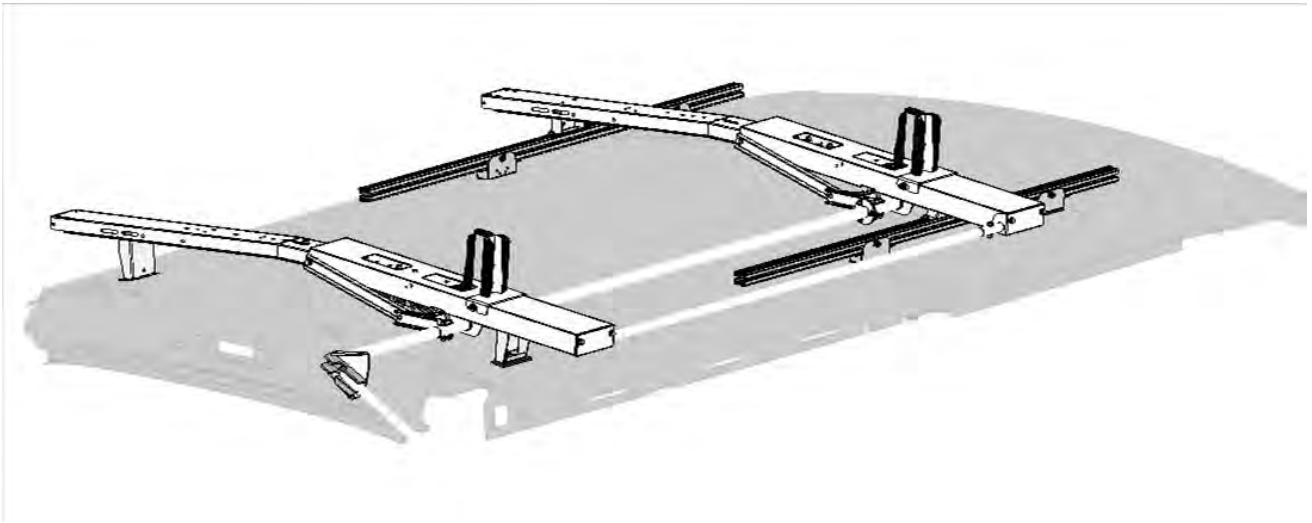

---

**\*PLEASE READ ALL INSTRUCTIONS AND WARNINGS PRIOR TO ASSEMBLING,  
INSTALLING, AND USING THIS PRODUCT\***

---

### Warning



Always check for wires, fuel tanks and lines, brake lines and other important vehicle functionality items prior to drilling and installing all products.

---

### Tools Needed





1/2" Wrench and Socket	7/16" Wrench and Socket
9/16" Wrench and Socket	Tape Measure
Phillips Drive	

---

### **Before You Begin**

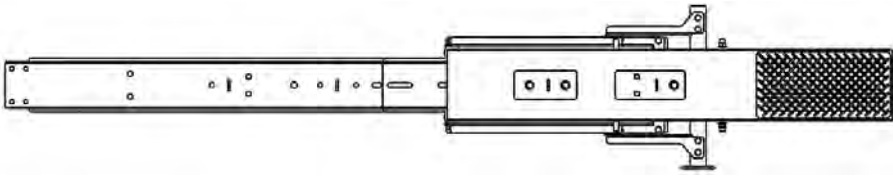
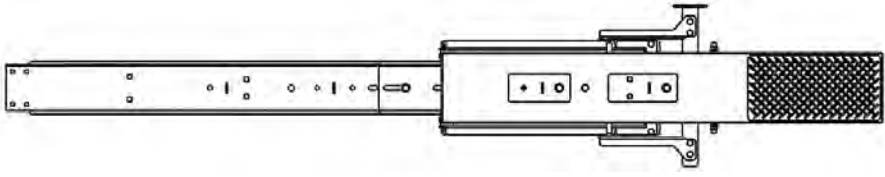
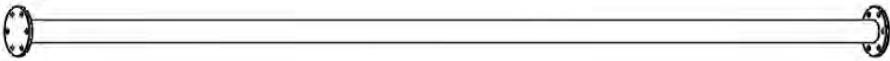
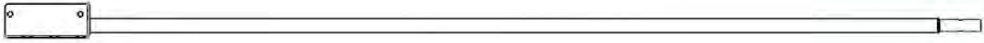
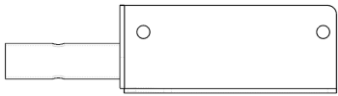
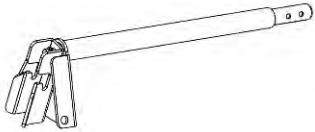



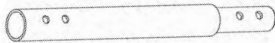
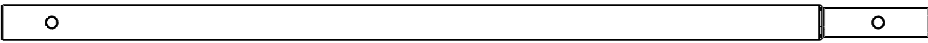

- Read all instructions.
-

Parts

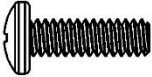
	4099H PARTS	DESCRIPTION	QTY
A		Front Bow Assembly	1
B		Rear Bow Assembly	1
C		Torque Tube	1
D		Support Tube	1
E		Support Tube End	1
F		Actuator	1
G		Removable Handle	1
H		Ladder Hook	2
I		Ladder Stop	2
J		Torque Tube Extender	1
K		Handle Extender	
L		Support Tube Extender	1
		HARDWARE	1

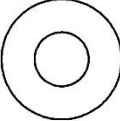

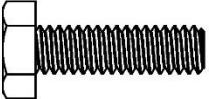
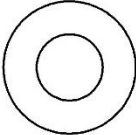
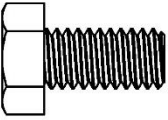
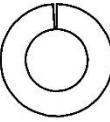
Hardware

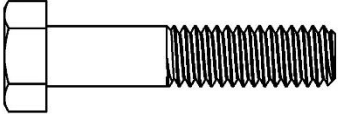
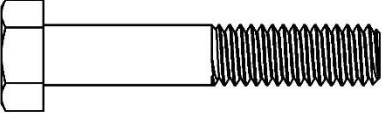
ITEM NO.	TO SCALE	DESCRIPTION	QTY.
1		10-24 x .625 PH Phillips Drive	2
2		10-24 Nyloc Nut	2
3		.25 flat washer	18
4		.25-20 NYLOC NUT	9
5		.25-20 x .875 HH	9
6		.312 Flat Washer	10
7		.312-18 x .625 HH	4
8		.312 Split Lock Washer	4
9		.312-18 Nyloc Nut	3
10		.312-18 x 1.50 HH	1
11		.312-18 x 1.75 HH	2
12		Handle Bar Holder	2
13		E6000	1

## Step 1 – Install Actuator

- This can be done on or off the van.
- Remove existing hardware from the Rear Bow Assy. (B) as shown
- Keep Hardware, This will be re-used.
- Install the Actuator (F) with the “triangle” opening towards the end of the bow.
- Be sure to put E6000 into tube swedge and around the bolt holes.

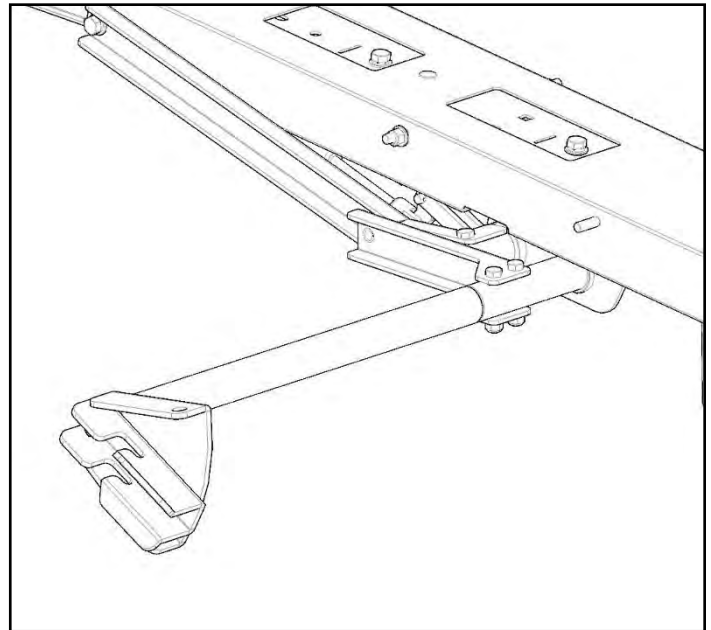
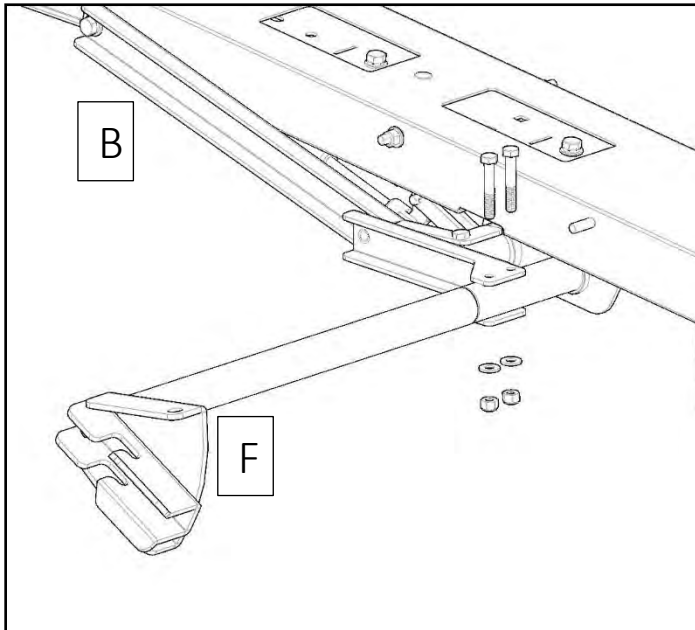

If installing on a High Roof Extended Transit, the Handle Extension (L) will be used. This extension goes inbetween the rear bow (B) and the actuator (F).

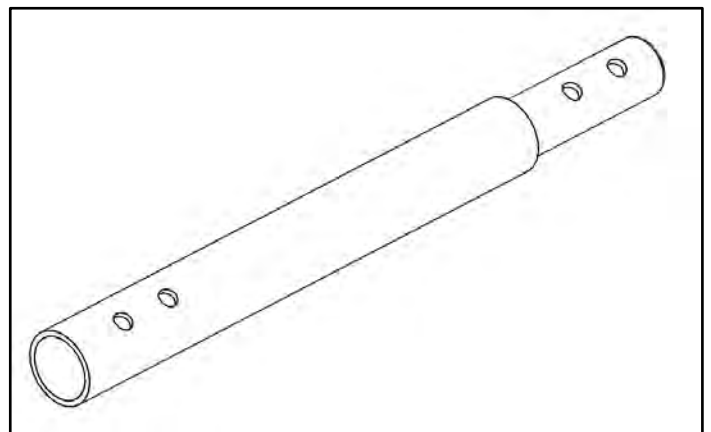

## Step 2 – Install Front and Rear Bow

\*If you have a lift you can skip this step and continue building the rack on a bench\*

### A. Rear Bow

- Set Rear Bow Assy. (B) on rear mounting feet as shown.

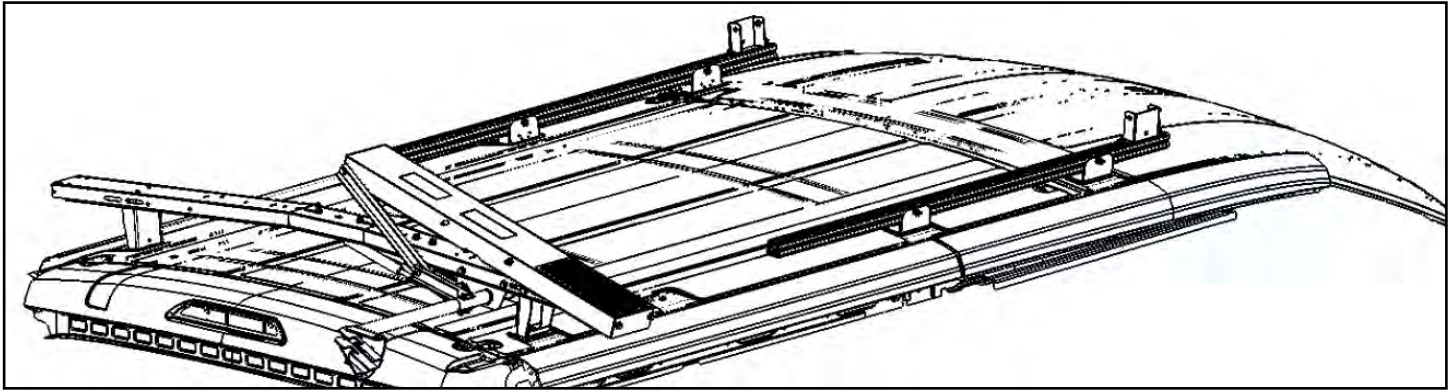

- Place a foam block from the packaging to hold the bow in the up position in order to access the mounting slots.
- Insert .375" x .75" hex head bolts (13) with .375" flat washer (12) and .375" lock washer (11) as shown.
- Leave loose until the the rack is assembled.
- Repeat on other side of bow.

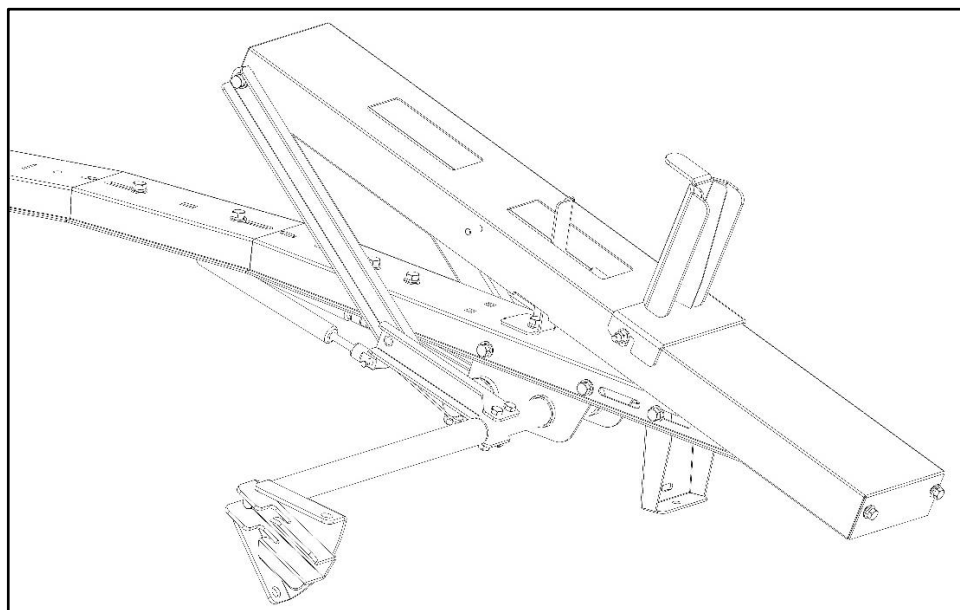
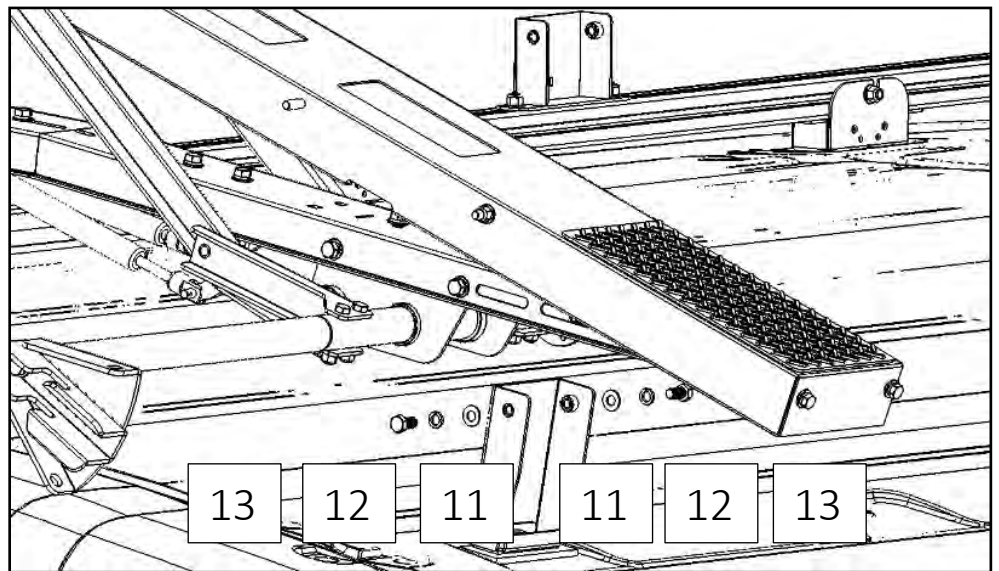

## B. Front Bow

- Repeat the process for the front bow (A).

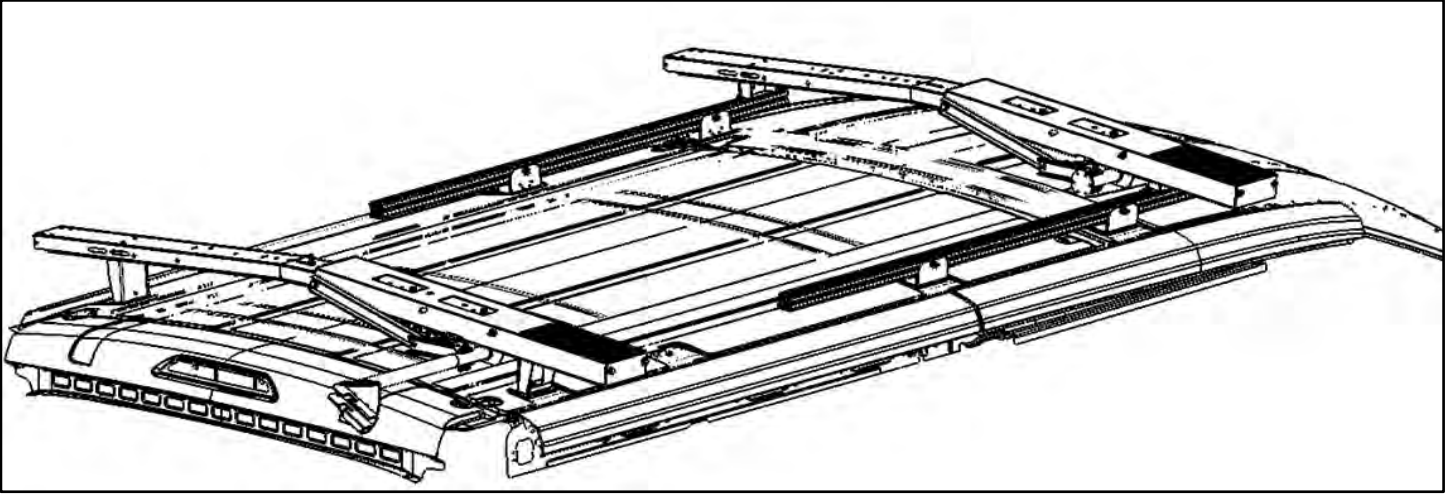

## Step 3 – Torque Tube Installation

**\*\*BE SURE THE BOTH FRONT AND REAR LADDER PANS ARE ALL THE WAY DOWN ON THE BOWS WHILE TIGHTENING\*\***

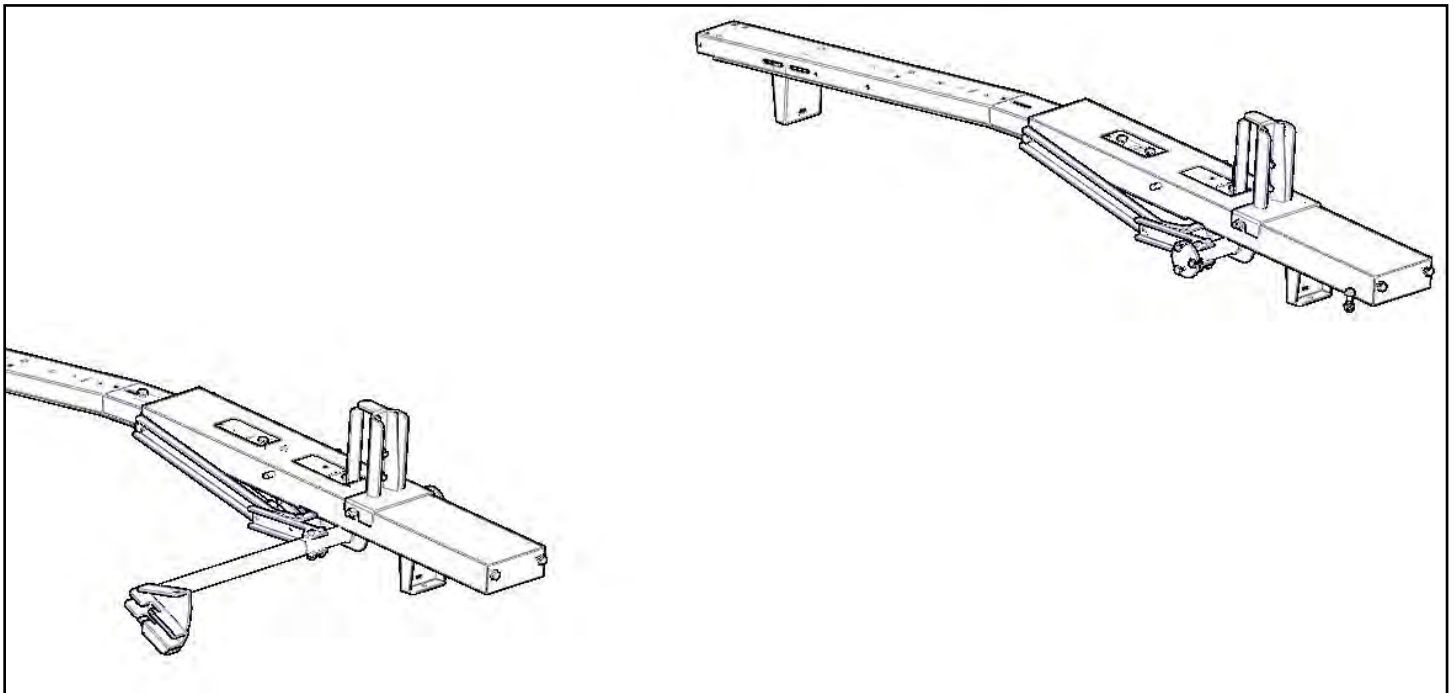



- Bolt Torque Tube(C) to Rear Bow Assy(B) using three .25" x .875" hex head bolts (5) six .25" flat washers(3) and three .25" nyloc nuts(4).

**\*\*You may want to put a foam packing block under the front of torque tube (C) to make it level while tightening.\*\***

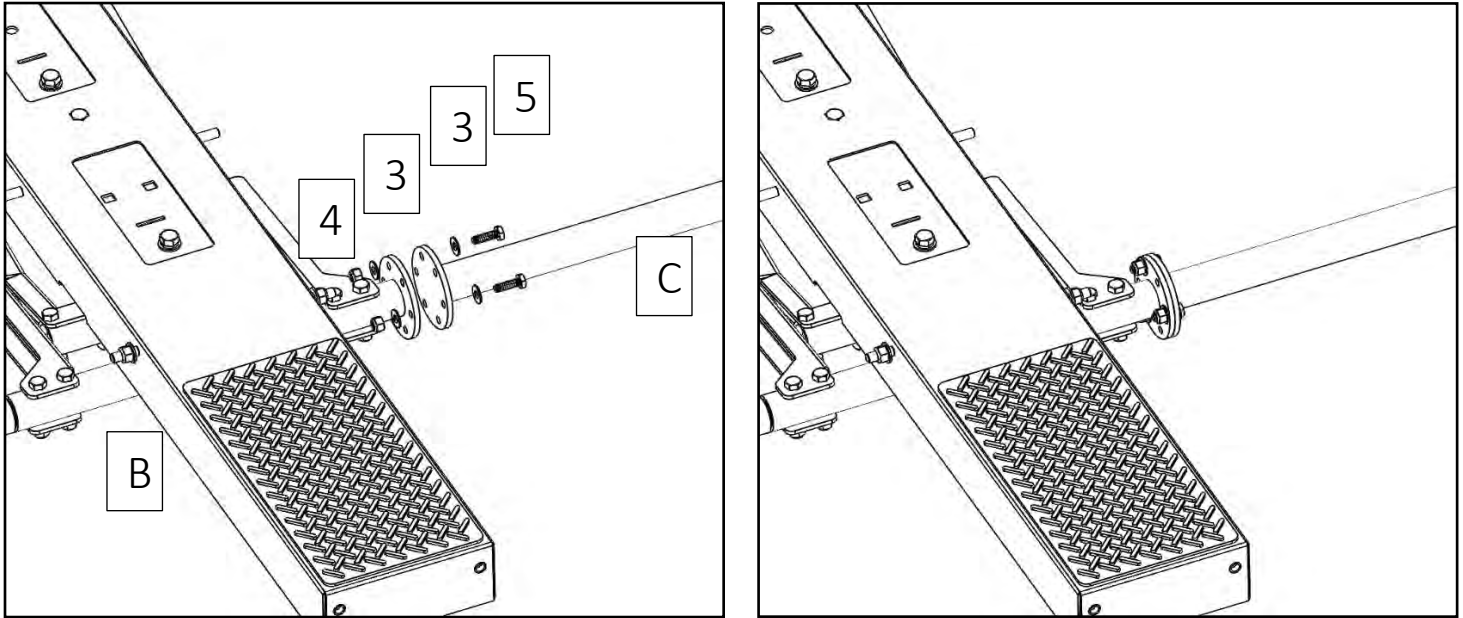

- Repeat process to bolt to the front bow assembly(A).

**\*\*If installing on a High Roof Extended Transit, the Torque Tube Extension (K) will be used\*\***  
This extension goes inbetween the torque tube (C) and the front bow (A)

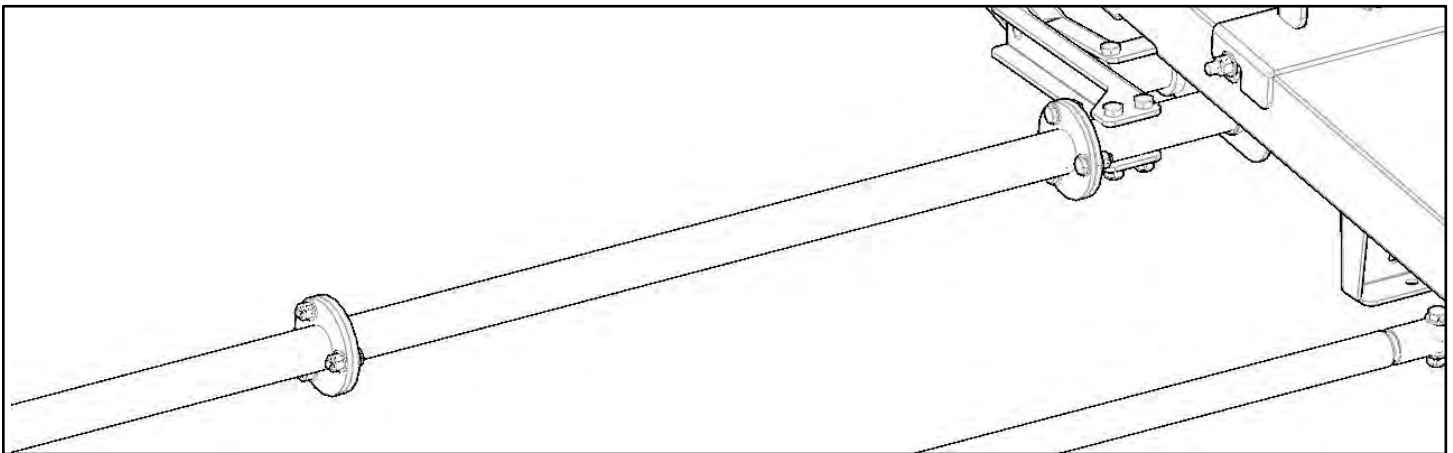



## Step 4 – Ladder Pan Support

### A.

- Assemble Support Tube(D&E). Put E6000(13) into tube swedge and around the bolt holes to prevent water from getting into tubes.

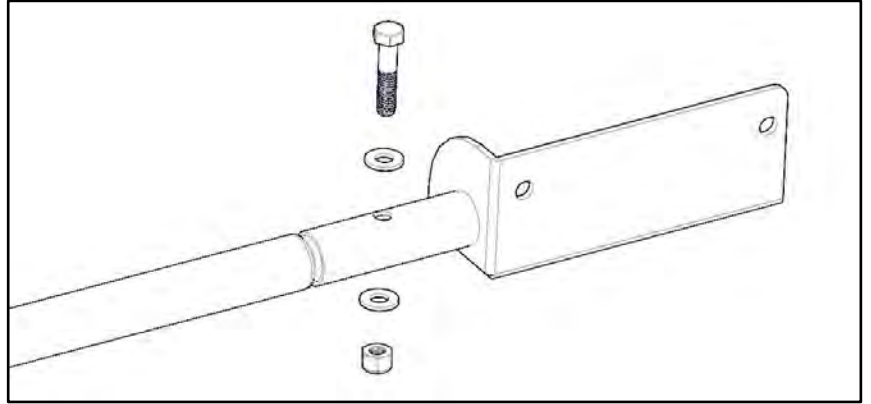

**\*\*If installing on a High Roof Extended Transit, the support tube extension (L) will be used\*\***  
This extension goes inbetween the support tube (D) and the support tube end (E)

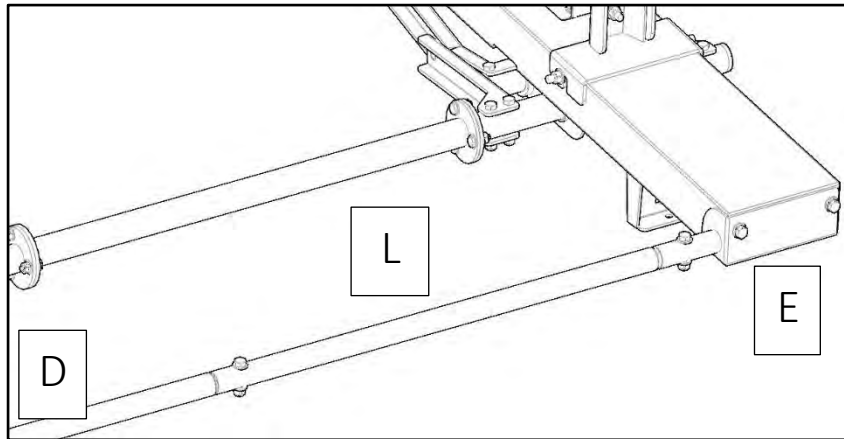

### B.

- Attach Support Tube(D&E) to the Ladder pan as shown using .312" x .625 hex head (7) with .312" lock washers(8) and .312" flat washers(6)

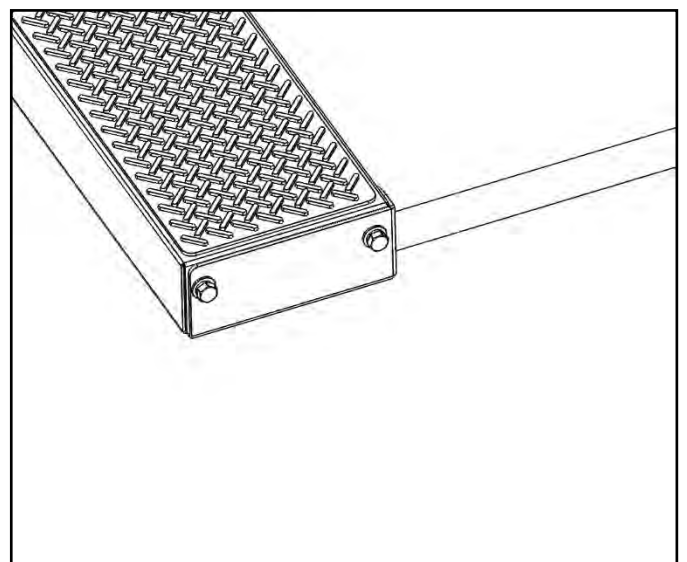
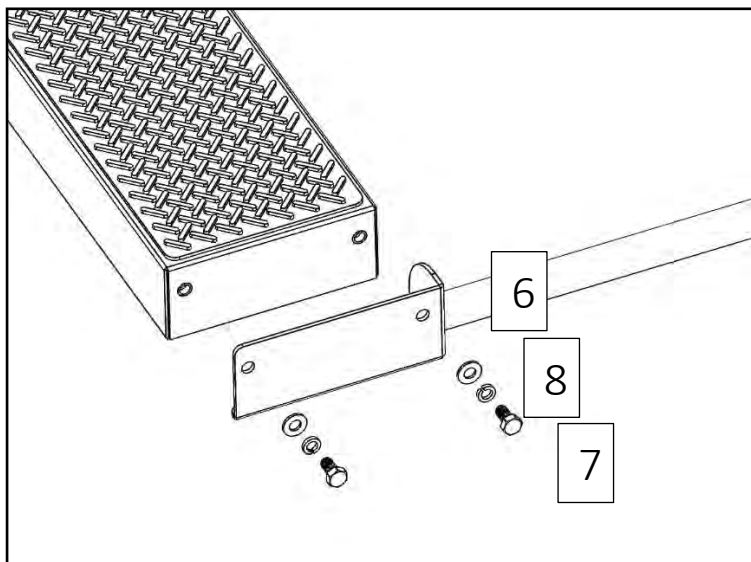

## Step 5 – Ladder Stops and Hooks

- On the front bow (A), remove 3/8"x3/4" bolt, 3/8" split lock washer and 3/8" flat washer from shown location and install Ladder Stop(I).

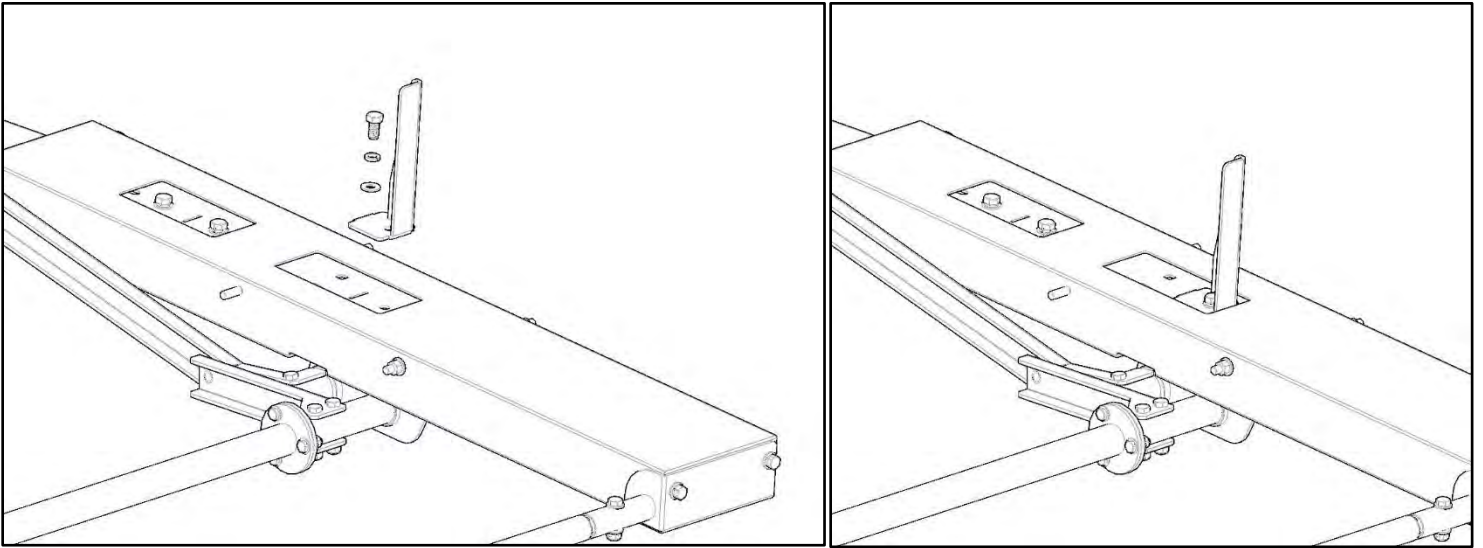

- Bolt Ladder Hook (H) to the lower position where the pem studs are installed. Use a .312 flat washer(6) and a .312 nyloc nut (9).

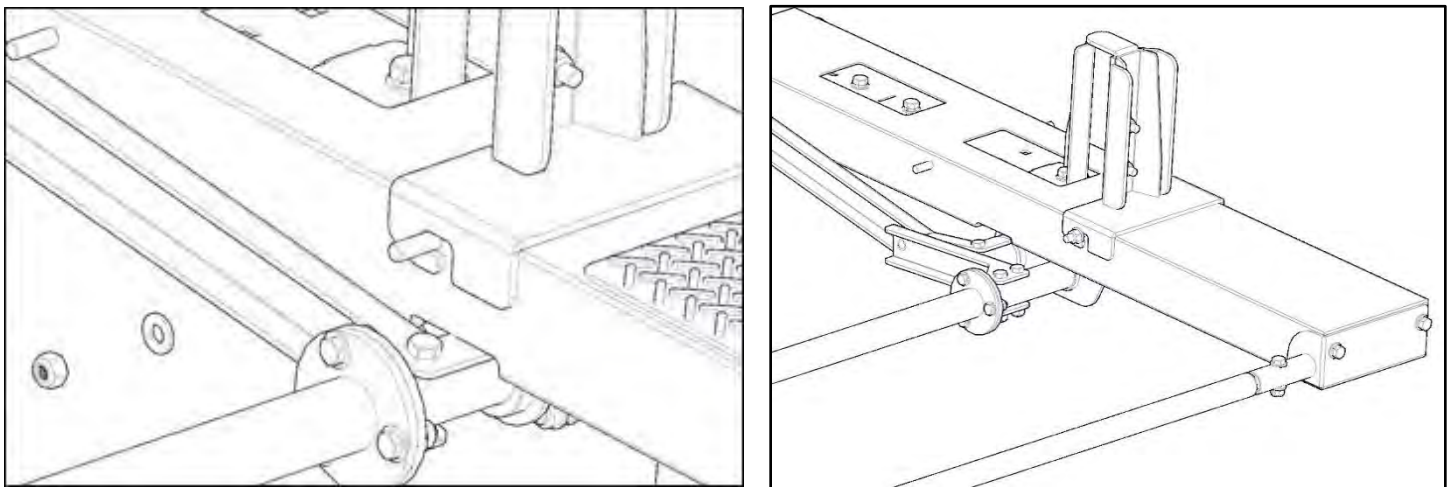

- Repeat on both sides of ladder hook (H).
- If using an "Extension Ladder" put the Ladder Stop(I) at the same location on the Front & Rear Bow Assy.(A&B).

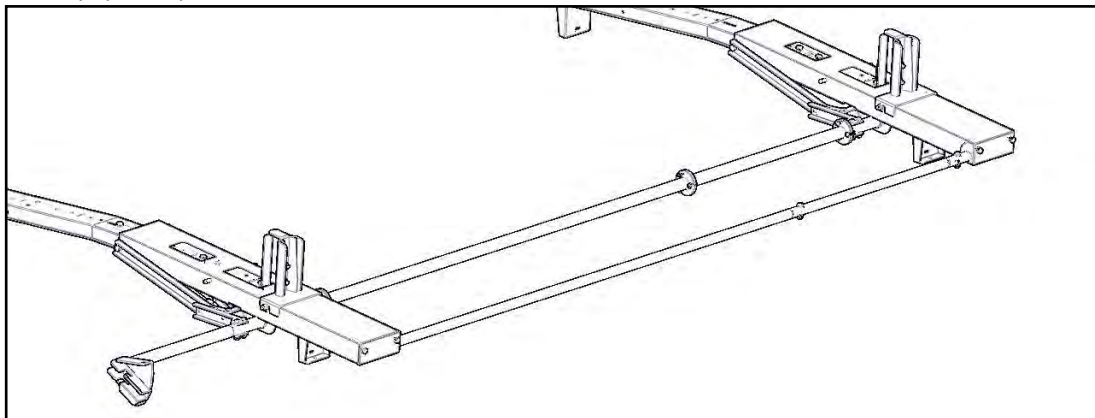

## Step Ladder Set-Up

- If installing for a “Step ladder”, The ladder hook (H) and the ladder stop (I) change positions on the rear bow.
- Both of these parts move higher up on the bow and are installed using the other pem studs.

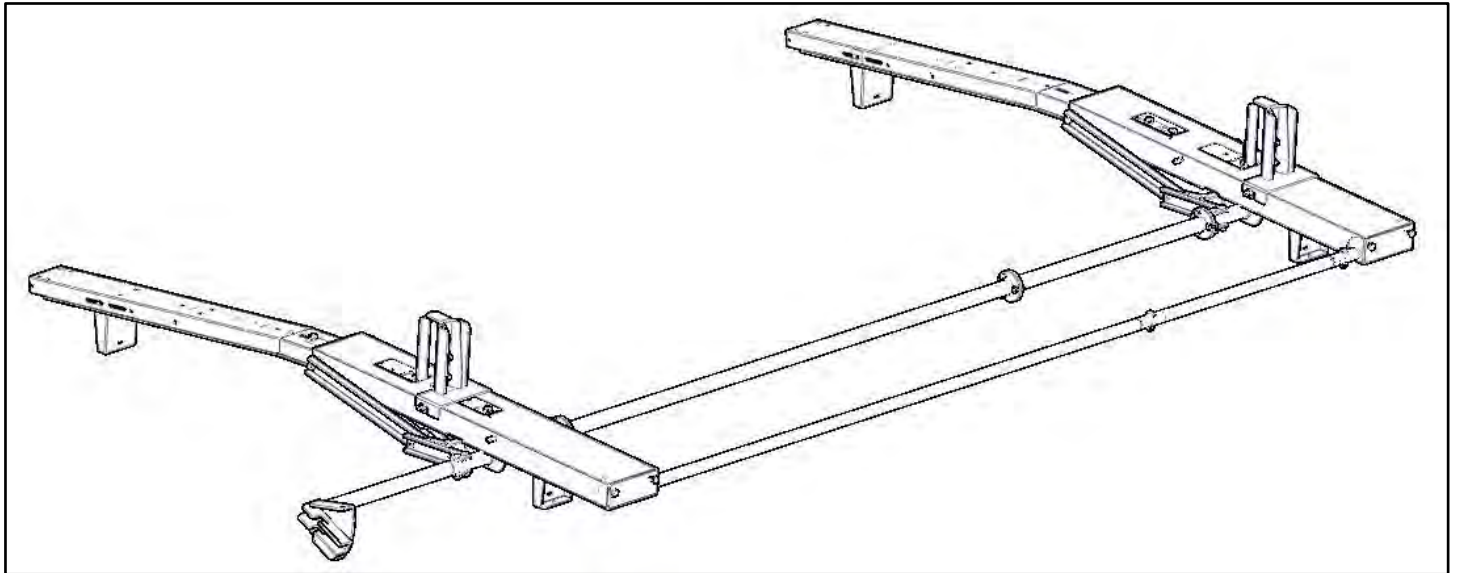
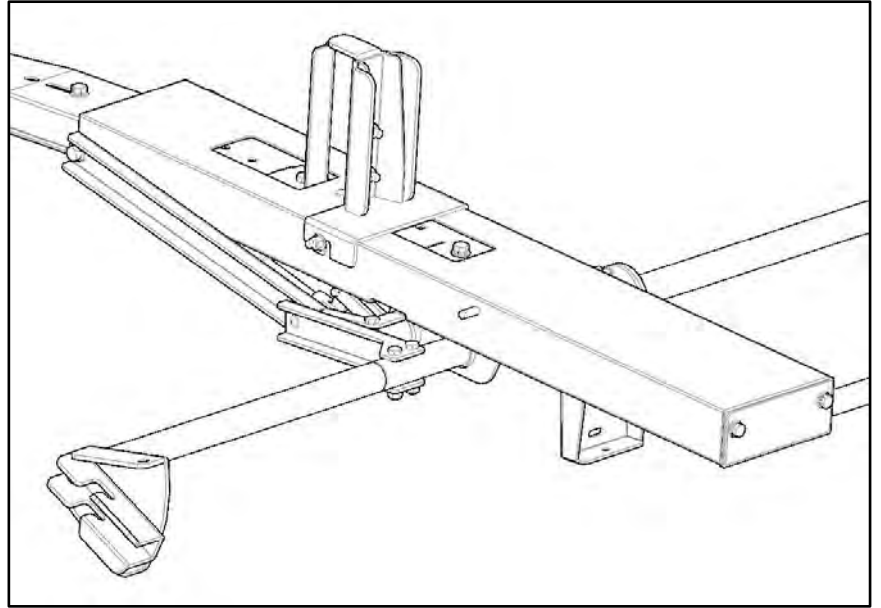

## Step 6 – Installing Rack

- If you built the rack on the bench you can now set the rack on the mounts as described in Step 2.
- Be sure rack is centered on the van then TIGHTEN all the hardware.

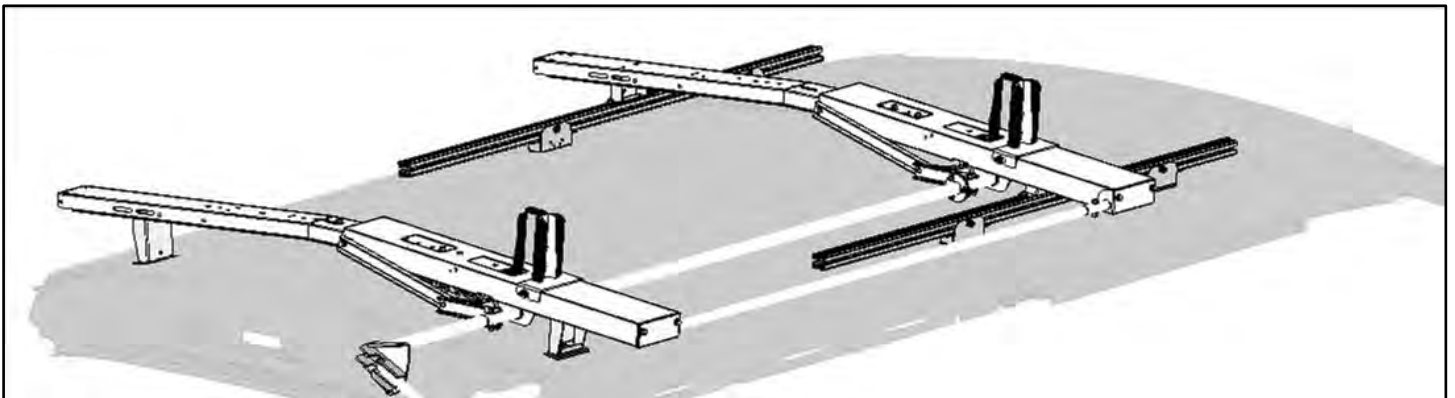

## Step 7 – Install Handle Bar holder

- Install handle bar holder clip from hardware kit to your preference. Most install at the rear of the van, on the backside of a shelving unit.
  - Install clips using #10 hardware provided.
- 

**GO BACK AND ENSURE ALL HARDWARE IS TIGHT**

Your installation is now complete.

---