

---

# **KARGO MASTER<sup>®</sup>**

**WE PUT EVERYTHING WITHIN REACH.**

---

Installation Guide

---

4081P Instructions

---

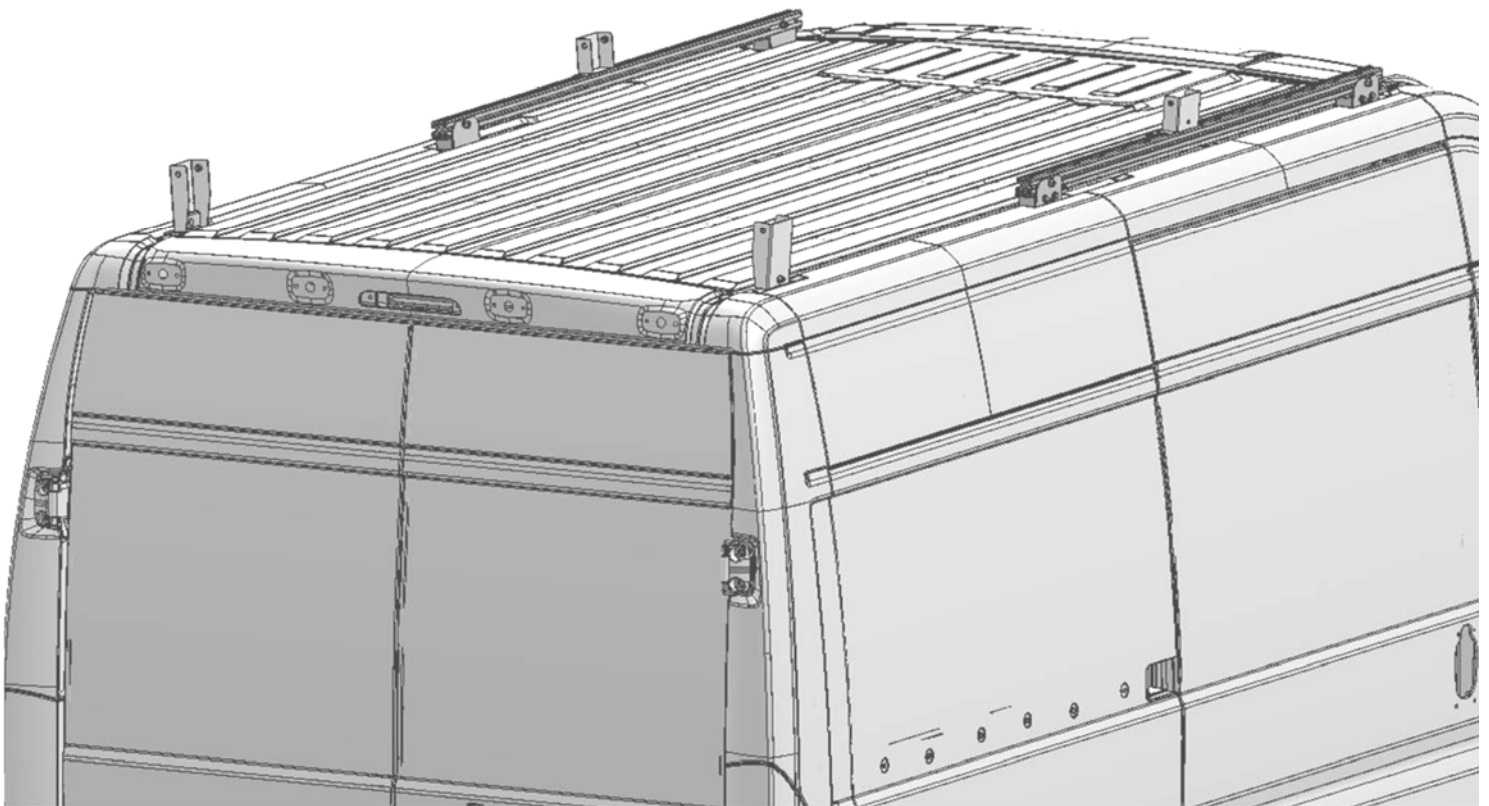

---

**\*PLEASE READ ALL INSTRUCTIONS AND WARNINGS PRIOR TO ASSEMBLING,  
INSTALLING, AND USING THIS PRODUCT\***

---

## Warning



Always check for wires, fuel tanks and lines, brake lines and other important vehicle functionality items prior to drilling and installing all products.

---

## Tools Needed



1/2" Socket and Wrench	7/16" Socket and Wrench
1/8" Allen Hex	Tape Measure

---

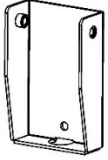
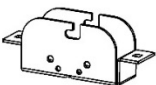
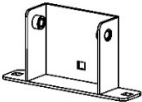

## Before You Begin

- Read all instructions.
  - Follow assembly instructions found with the rack to assemble and install rack.
-





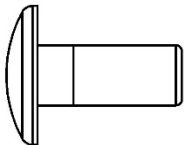
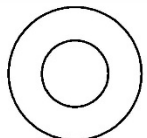

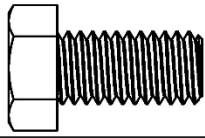
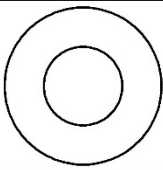
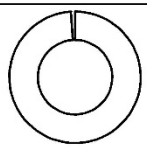
Parts

ITEM NO.		PART NUMBER	DESCRIPTION	QTY.
A		40818-20-001-R1	62in Extrusion	2
B		40818-25	Tall Foot Bracket	2
C		40818-20-003-R2	Raise Foot Bracket	4
D		40818-10	Short Foot Bracket	2
E		40818-20-007-R1	Rear Mount Bracket	2
		18-40818-FT-R1	Foot Bolt Kit	1
		18-40818-P	Promaster Bolt Kit	1

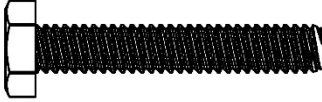
Hardware 18-40818-FT-R1

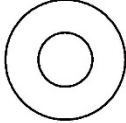
ITEM NO.	TO SCALE	DESCRIPTION	QTY.
1		5/16-18x3/4 Carriage Bolt	16
2		5/16 Flat Washer	16
3		5/16-18 Nyloc	16
4		3/8"-16 x 3/4" Hex Head	8
5		3/8" Flat Washer	8
6		3/8" Split Lock Washer	8

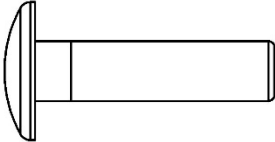
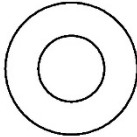
Hardware 18-40818-P

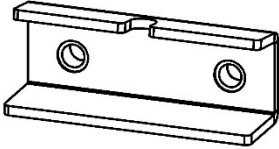
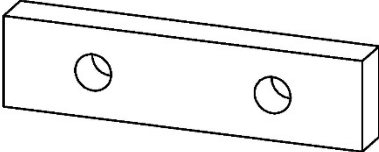
ITEM NO.	TO SCALE	DESCRIPTION	QTY.
7		1/4"-20 x 1-1/2" Hex Head	8
8		1/4" Split Lock Washer	8
9		1/4" Flat Washer	8
10		#10-32 x 1/2" Button Head	8
11		#10 lock washer	8
12		5/16"-18 x 3/4" Carriage Bolt	2
13		5/16" Flat Washer	2
14		5/16"-18 Nyloc	2
15		40818-23 SCALE 1:2	4
16		40818-20-006-R1	4

## Step 1 – Prepare Mount Blocks

- Attach spacer block inside mount block using #10-32 x .50 BHCS and #10 split lock washers as shown.
- Repeat on all four blocks.
- TIGHTEN

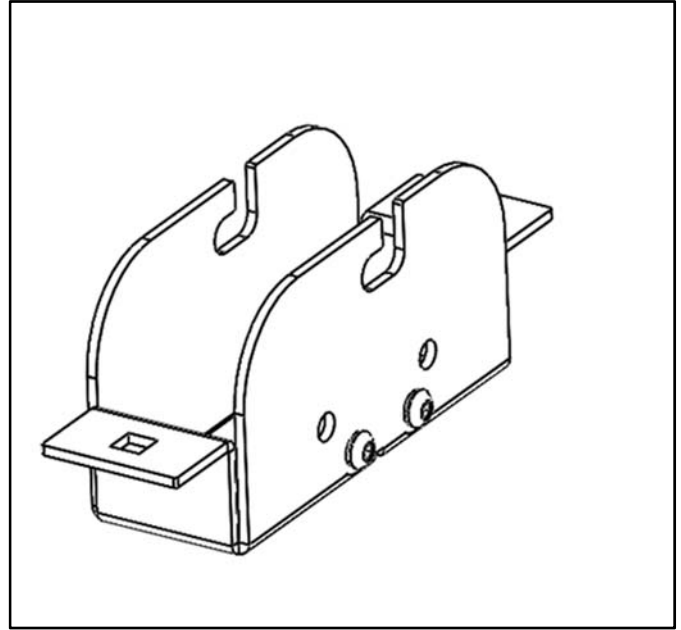
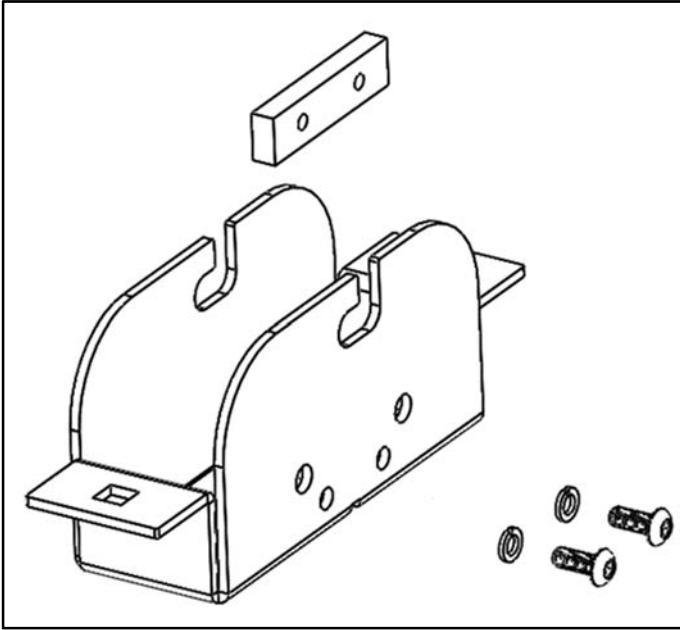

## Step 2 – Find Mount Locations on Roof of Van

- Locate the front two mounting locations on each side of van. This is where the mounting blocks will be mounted.

**\*\*This picture shows on a 136" wheel base, high roof van\*\***

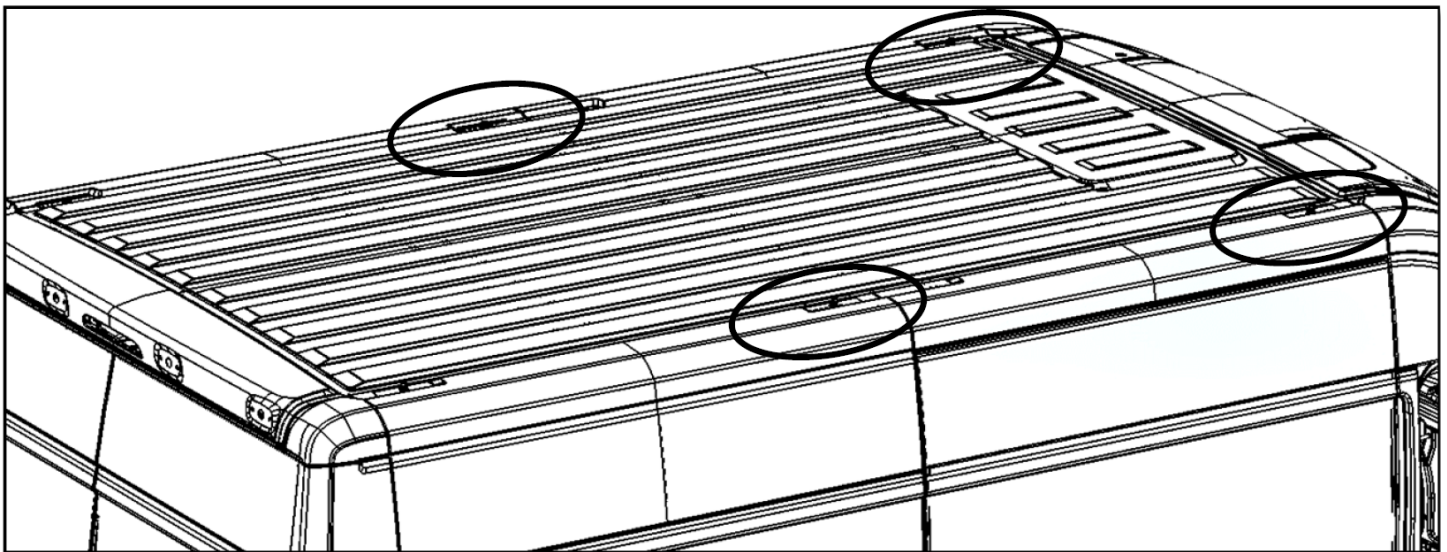

### Step 3 – Install Mount Block

- Set mount block assembly over the “T” stud extruding from the top of the roof.
- Insert mount clip as so the slot goes under the head of the “T” stud to mount tight.
- Bolt through the mount assembly and into the mount bracket using two 1/4" x 1-1/2" hex bolt, two 1/4" split lock washers and two 1/4" flat washers as shown.
- DO NOT OVER TIGHTEN
- Repeat in all corners for a total of 4x.

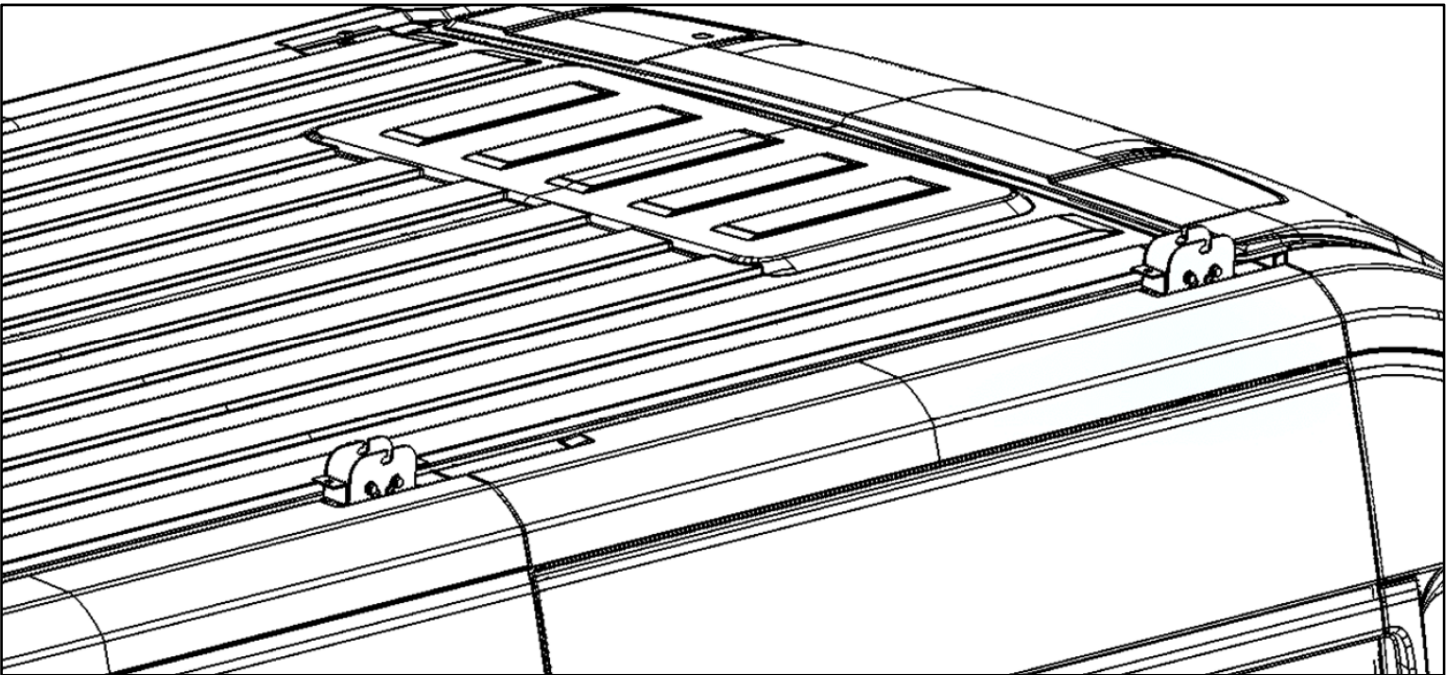
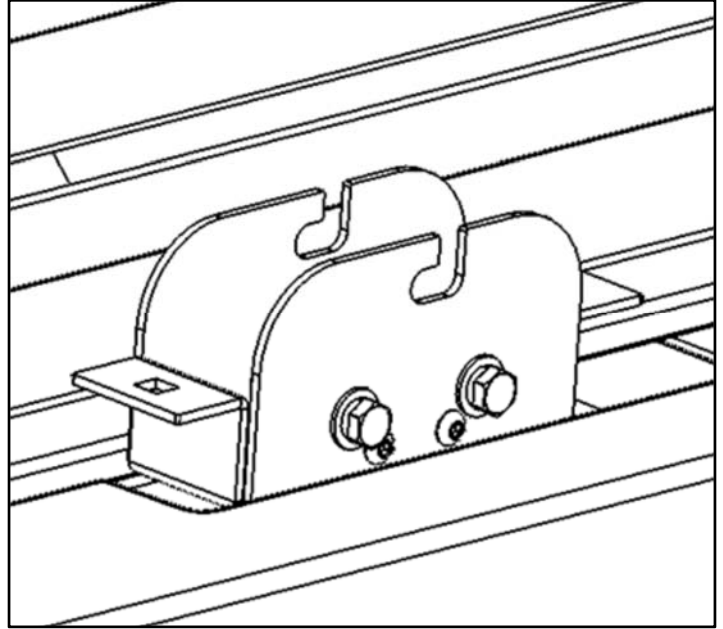
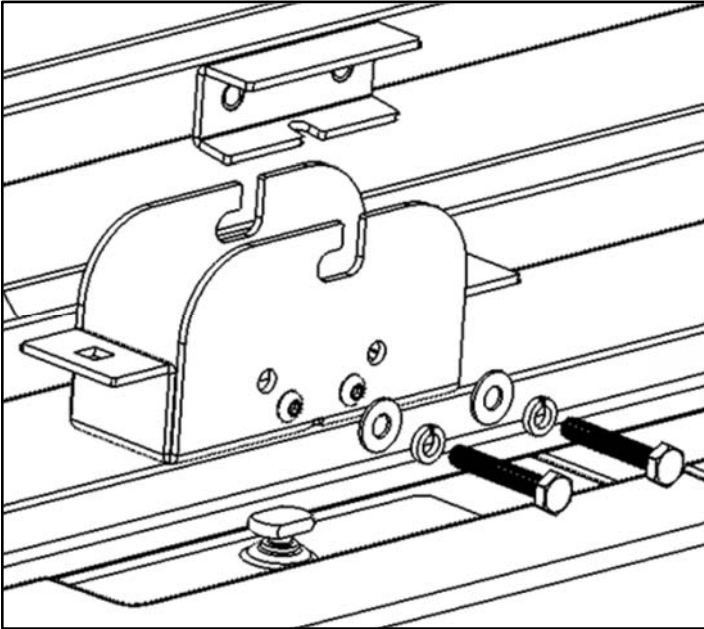

### Step 4 – Prepare Extrusion

- Slide two 5/16" x 3/4" carriage bolt into opposite slots of extrusion. These carriage bolts are in the foot mount kit (18-40818-FT-R1).
- Repeat on each rail, for a total of 8 carriage bolts on two rails.

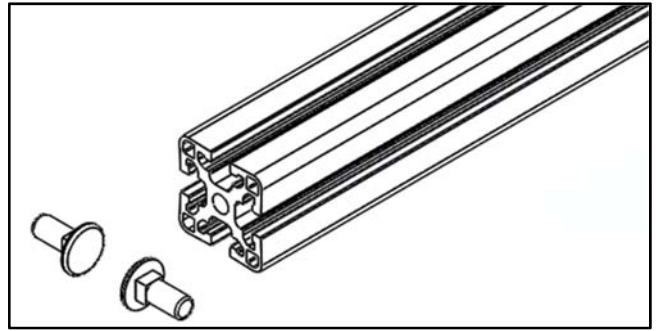

### Step 5 – Install Extrusion

- Place mount rail with carriage bolts onto the mount blocks that were installed in step 3.
- Line the carriage bolts up in the slot of the mount blocks.
- Bolt using previous carriage bolt, 5/16" flat washer and a 5/16" nyloc nut.
- Snug Tighten, But allow movement.

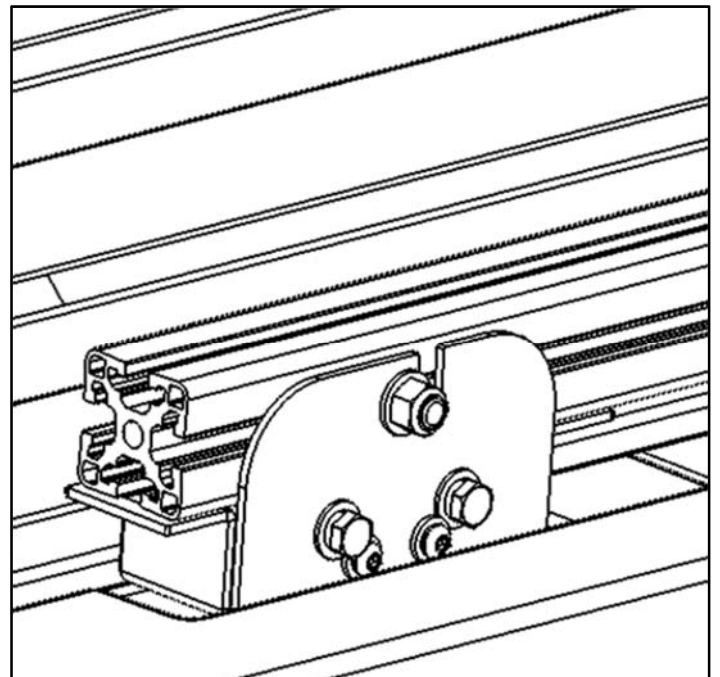
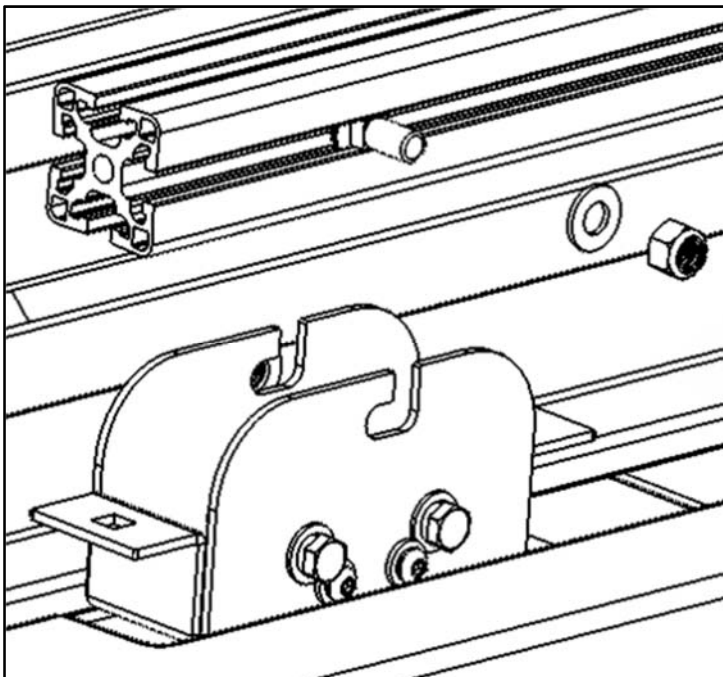
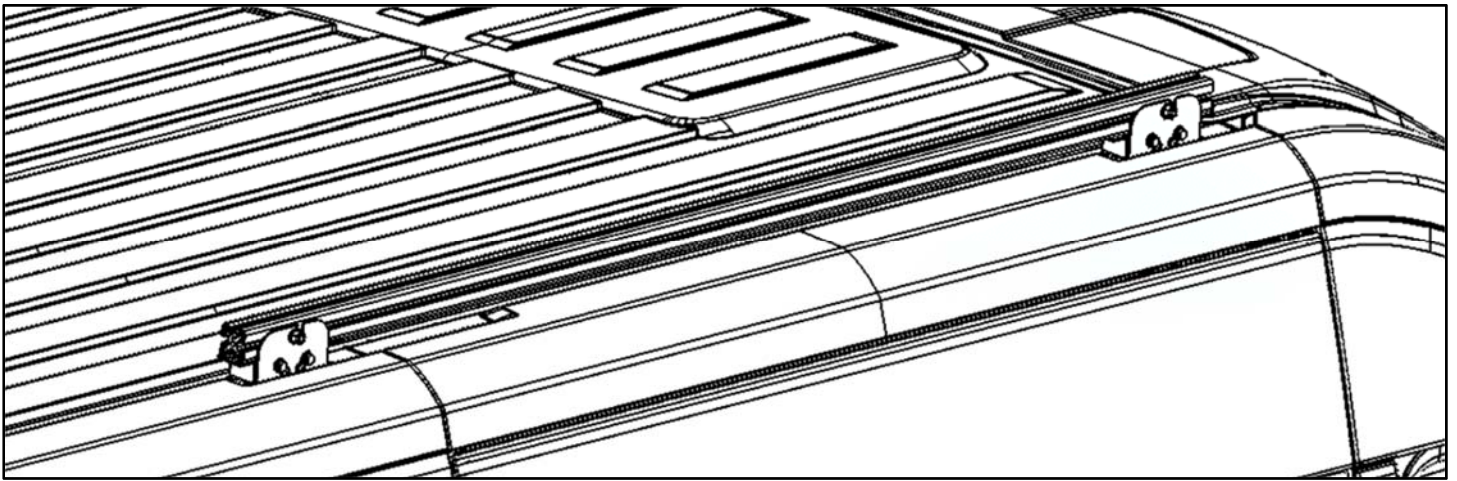

## Step 6 – Install Rear Foot

- Place rear foot over the “T” stud at the rear of the roof.
- Insert mount clip as so the slot goes under the head of the “T” stud to mount tight.
- Bolt through the mount bracket and the rear foot using a 5/16” x 1-1/4” carriage bolt, a 5/16” flat washer and a 5/16” nyloc nut.
- DO NOT OVER TIGHTEN. Leave some room for adjustability until rack in on vehicle.
- Repeat on other side.

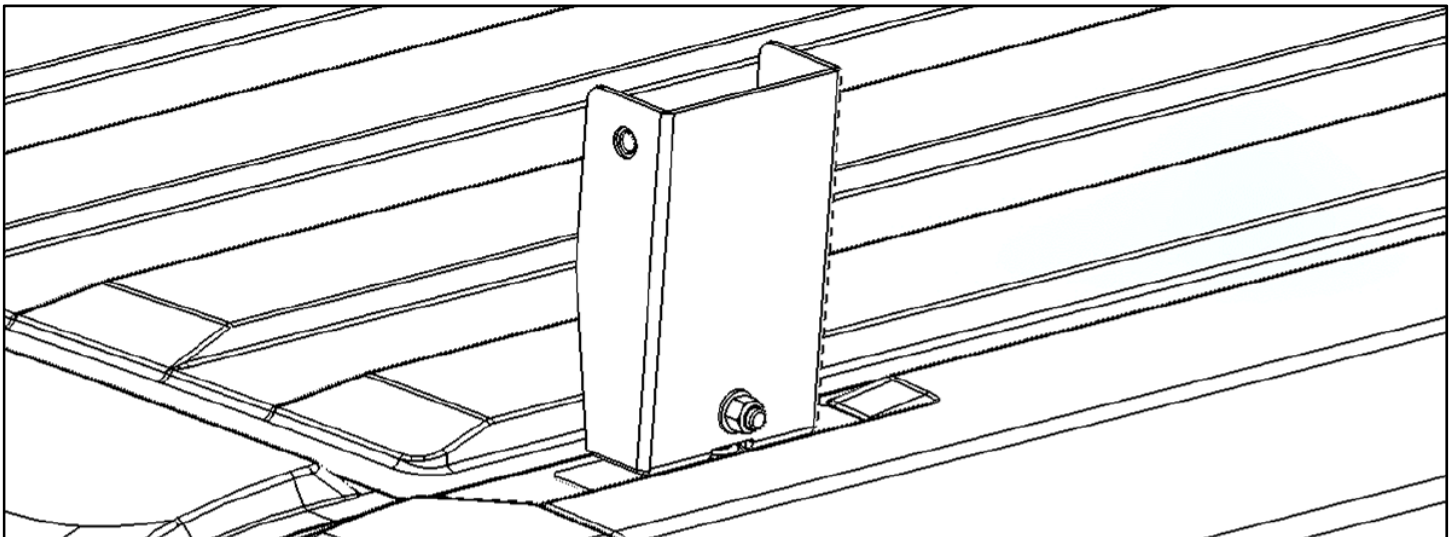
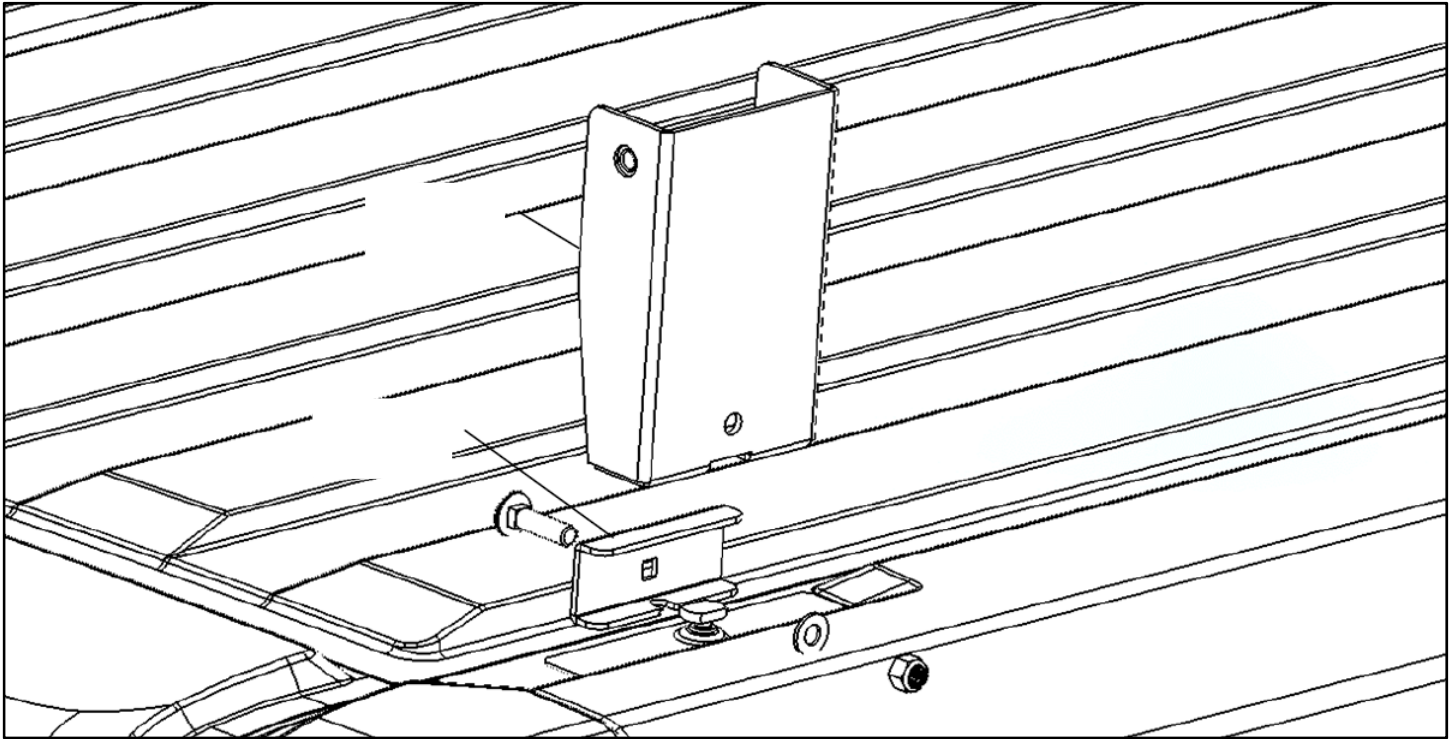

## Step 7 – Install Mount Foot

- Slide two 5/16" x 3/4" carriage bolts into the top slot of the mounted extrusion.
- Place mount foot over carriage bolts.
- Bolt together using carriage bolt, 5/16" flat washer and 5/16" nyloc nut.
- DO NOT TIGHTEN.

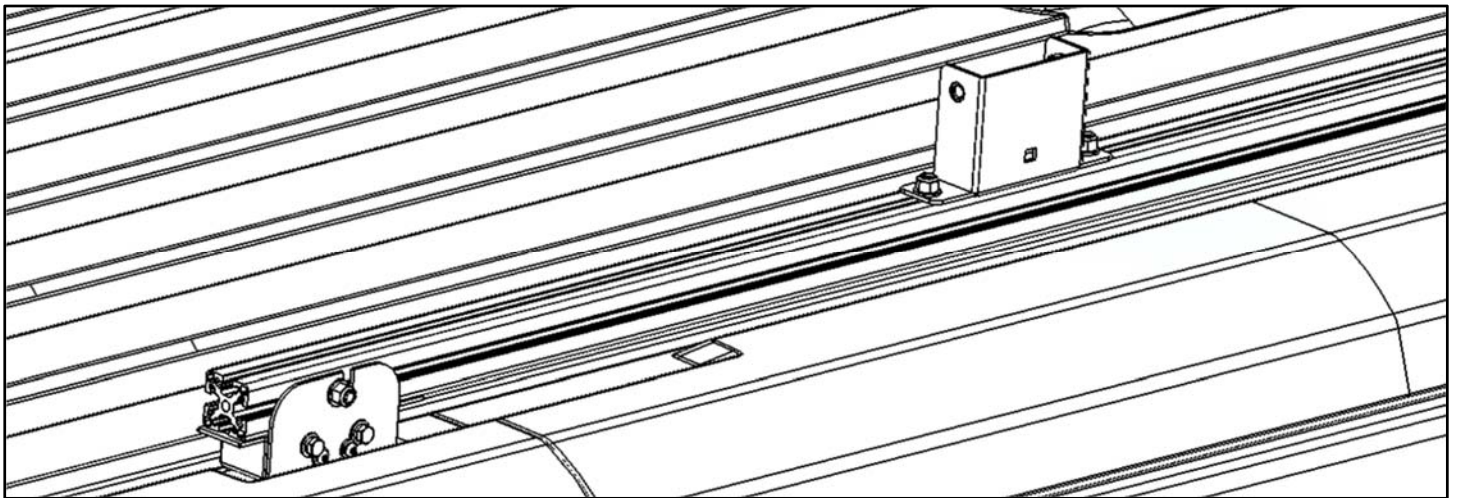
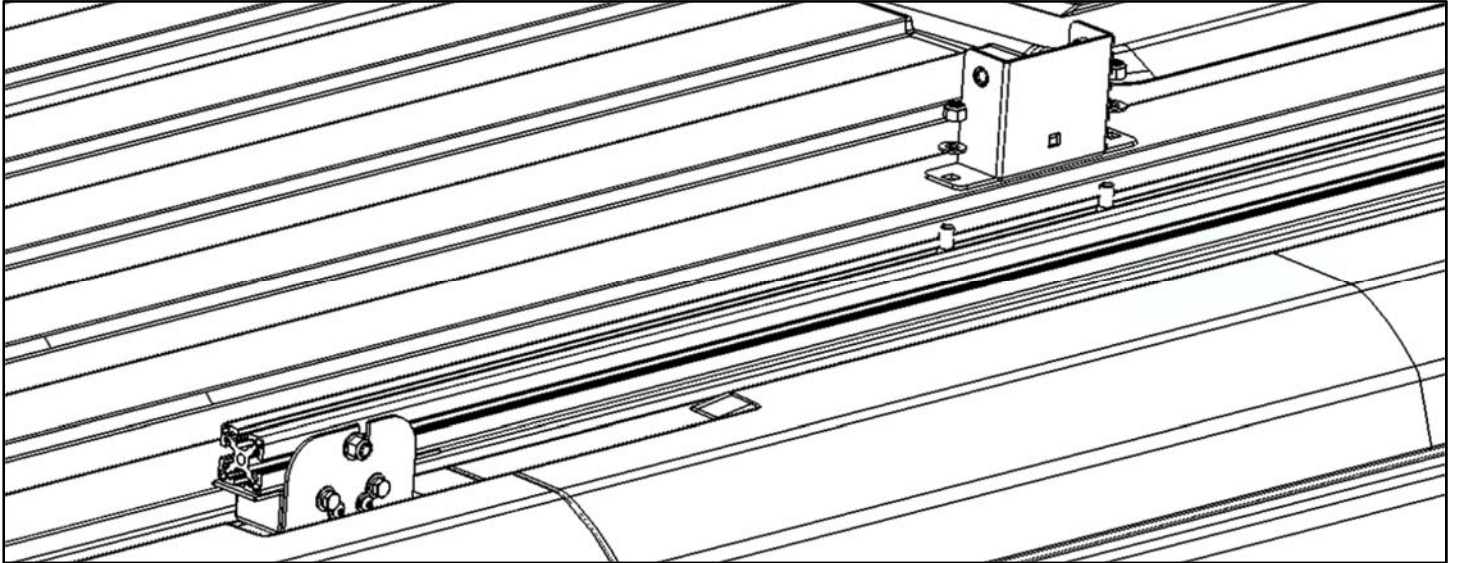

## Step 8 – Set Distance

- Set center to center distance from rear foot at 71.5" or 96". If using the extension, set at 96".

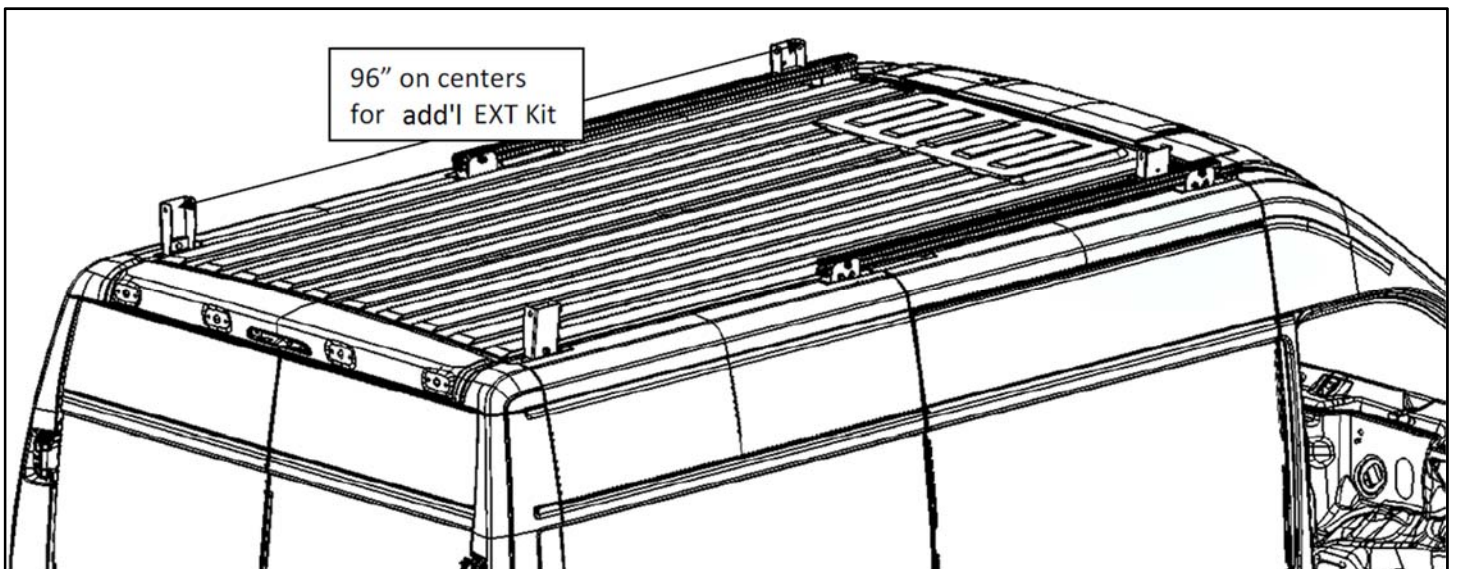
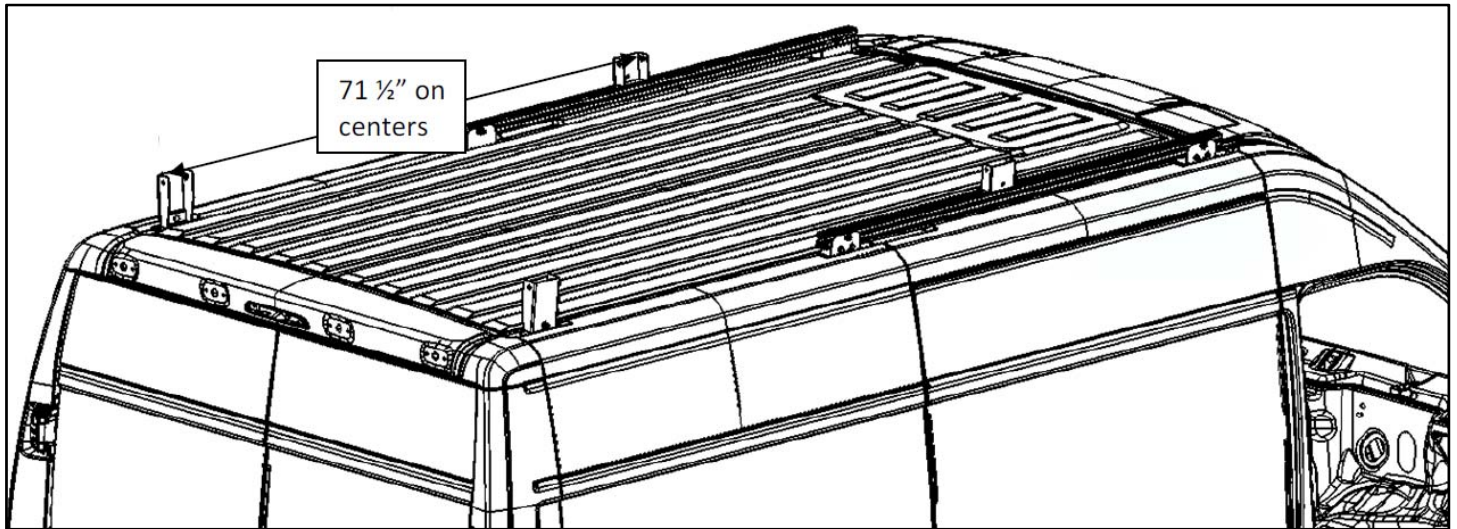

## Step 9 – Mount Feet to Rack

- Determine if the rack is being assembled on the vehicle or if the rack will be assembled off the vehicle and set on top of installed feet.
- In either case, bolt bows to feet using 3/8" -16 x 3/4" hex head, a 3/8" lock washer and a 3/8" flat washer in order shown.

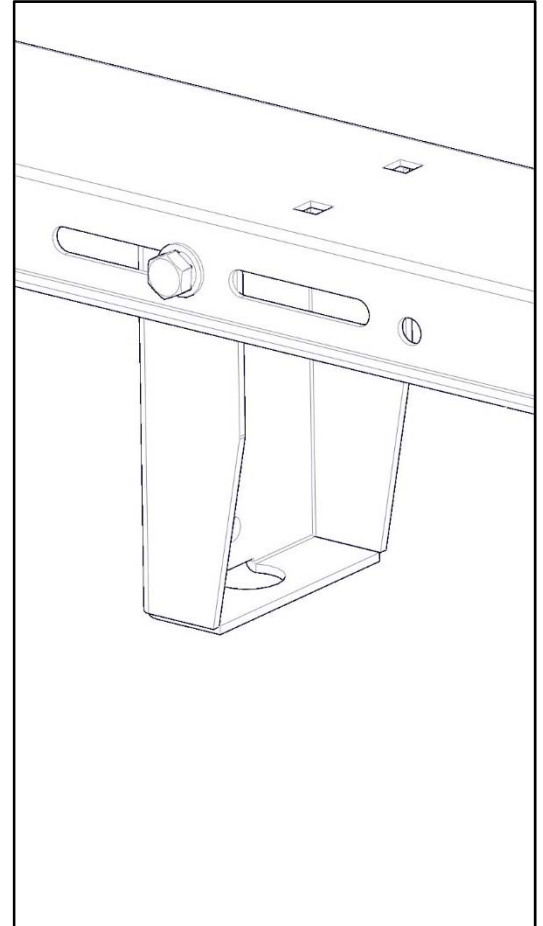
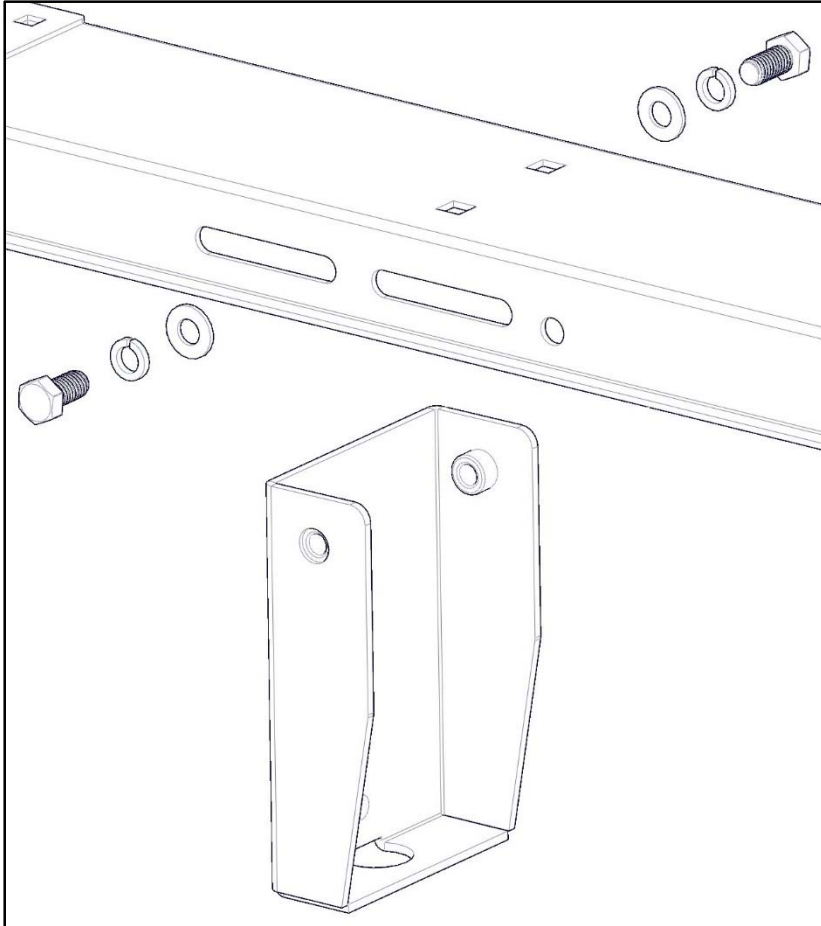

GO BACK AND ENSURE ALL HARDWARE IS TIGHT  
Your installation is now complete.

---

# **KARGO MASTER<sup>®</sup>**

**WE PUT EVERYTHING WITHIN REACH.**

---

## Installation Guide

---

### 4097M

---

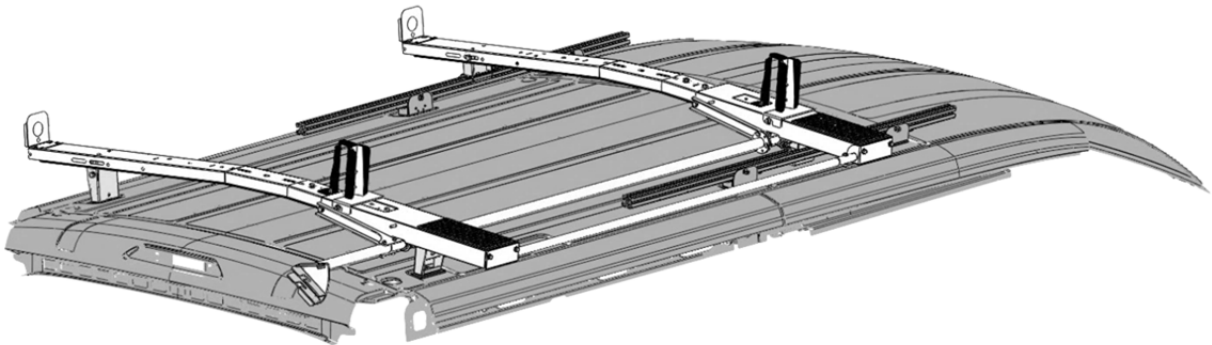

---

**\*PLEASE READ ALL INSTRUCTIONS AND WARNINGS PRIOR TO ASSEMBLING,  
INSTALLING, AND USING THIS PRODUCT\***

---

### Warning



Always check for wires, fuel tanks and lines, brake lines and other important vehicle functionality items prior to drilling and installing all products.

---

### Tools Needed







1/2" Wrench and Socket	7/16" Wrench and Socket
9/16" Wrench and Socket	Tape Measure
Phillips Drive	

---

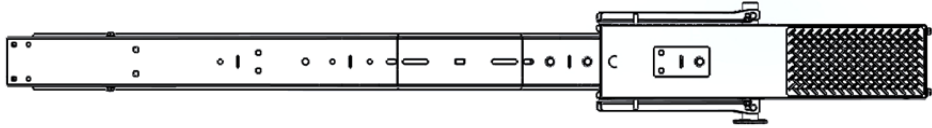
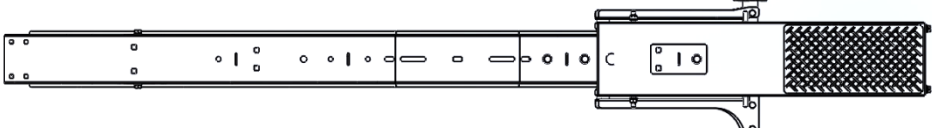
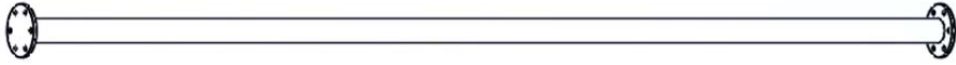

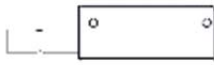

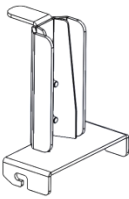

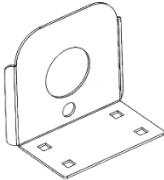

### Before You Begin

- Read all instructions.
-

Parts

ITEM NO.	4097M PARTS	DESCRIPTION	QTY
A		Front Bow Assembly	1
B		Rear Bow Assembly	1
C		Torque Tube	1
D		Support Tube	1
E		Support Tube End	1
F		Actuator	1
G		Removable Handle	1
H		Ladder Hook	2
I		Ladder Stop	2
J		Load Plate	2
K		HARDWARE	1

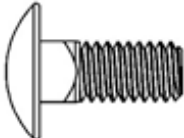
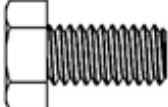
Hardware

ITEM NO.	TO SCALE	DESCRIPTION	QTY.
1		10-24 x .625 PH Phillips Drive	2
2		10-24 Nyloc Nut	2
3		.25 flat washer	12
4		.25-20 NYLOC NUT	6
5		.25-20 x .875 HH	6
6		.312 Flat Washer	8
7		.312-18 x .75 Carriage Bolt	4
8		.312-18 x .625 HH	4
9		.312 Split Lock Washer	4
10		.312-18 Nyloc Nut	4
11		E6000	1
12		Handle Bar Holder	2

## Step 1 – Install Actuator

- This can be done on or off the van.
- Remove existing hardware from the Rear Bow Assy. (B) as shown
- Keep Hardware, This will be re-used.
- Install the Actuator (F) with the “triangle” opening towards the end of the bow.
- Be sure to put E6000 into tube swedge and around the bolt holes.

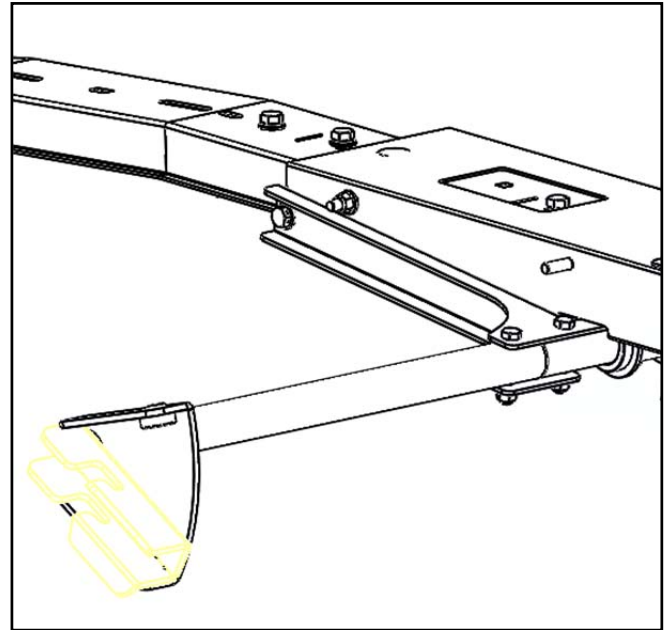
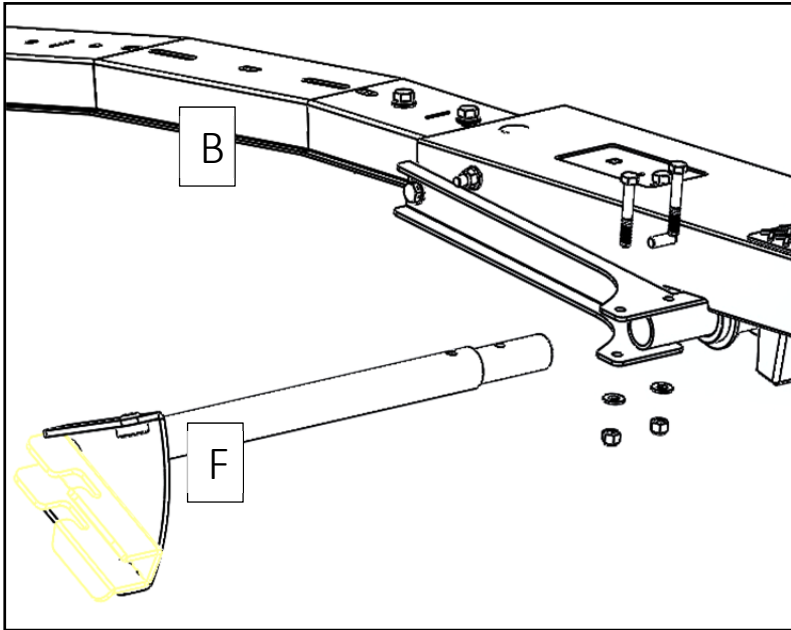

## Step 2 – Install Front and Rear Bow

\*If you have a lift you can skip this step and continue building the rack on a bench\*

- Set Rear Bow Assy. (B) on rear mounting feet as shown.
- Place a foam block from the packaging to hold the bow in the up position in order to access the mounting slots.
- Insert .375" x .75" hex head bolts (13) with .375" flat washer(12) and .375" lock washer(11) as shown.
- Leave loose until the the rack is assembled.
- Repeat on other side of bow.

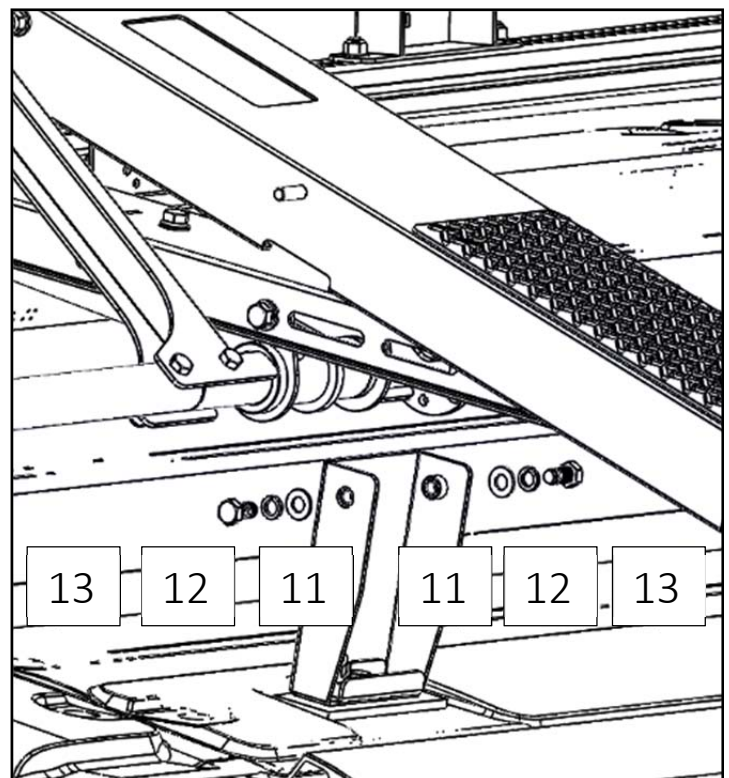

- Repeat the process for the front bow (A).

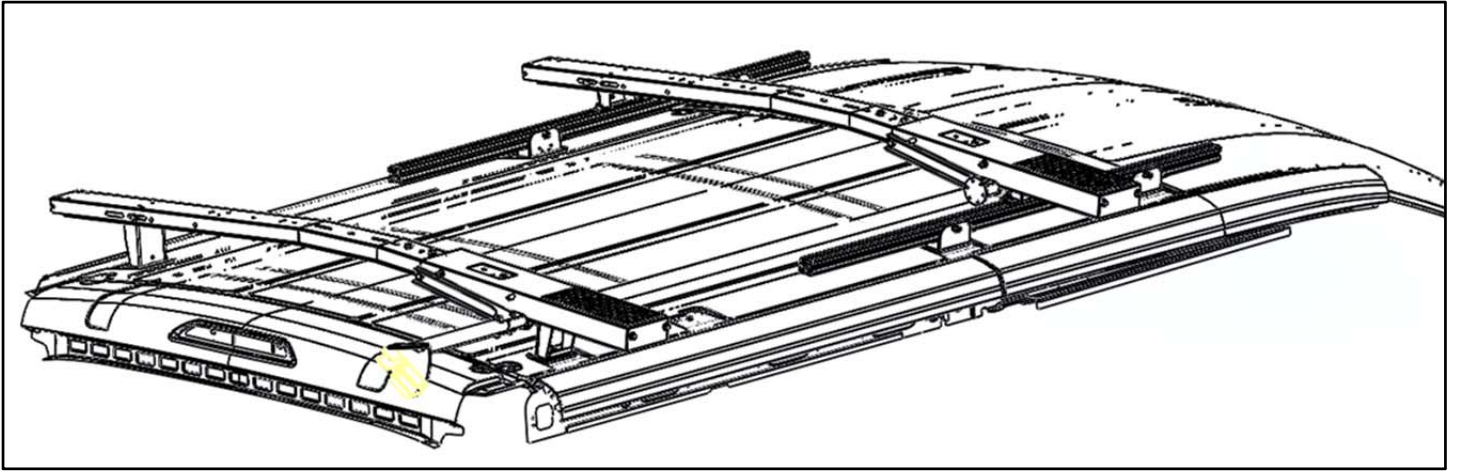

### Step 3 – Torque Tube Installation

**\*\*BE SURE THE BOTH FRONT AND REAR LADDER PANS ARE ALL THE WAY DOWN ON THE BOWS WHILE TIGHTENING\*\***

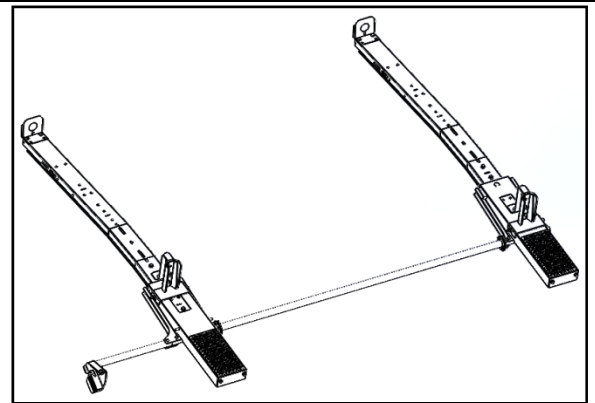

- Bolt Torque Tube(C) to Rear Bow Assy(B) using three .25" x .875" hex head bolts (5) six .25" flat washers(3) and three .25" nyloc nuts(4).

\*You may want to put a foam packing block under the front of torque tube (C) to make it level while tightening\*

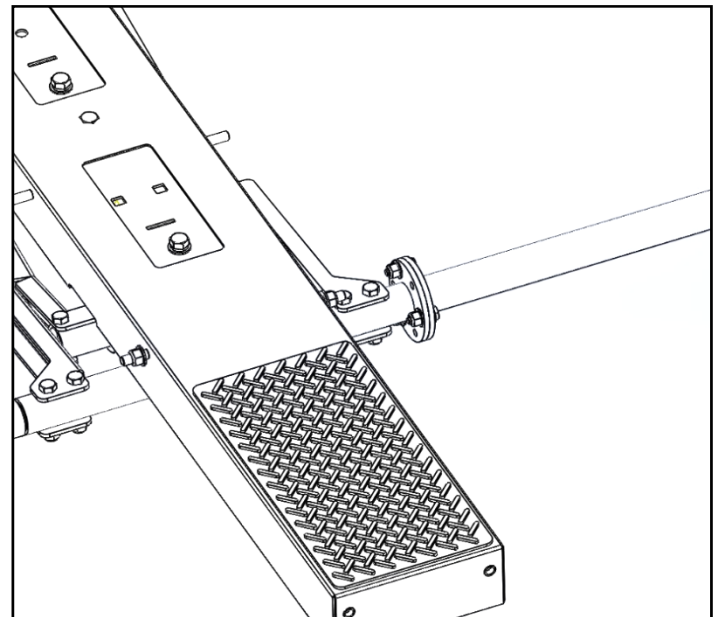
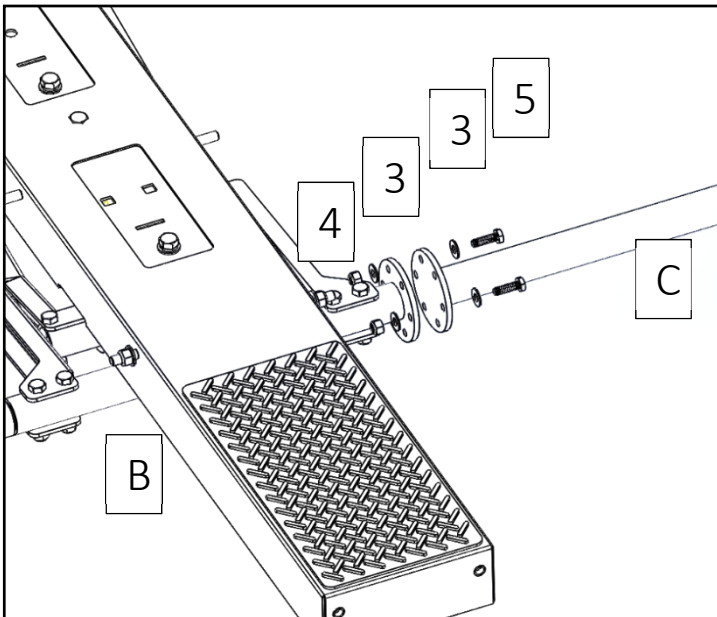

- Repeat process to bolt to the front bow assembly(A).

## Step 4 – Ladder Pan Support

### A.

- Assemble Support Tube(D&E). Put E6000(14) into tube swedge and around the bolt holes to prevent water from getting into tubes.

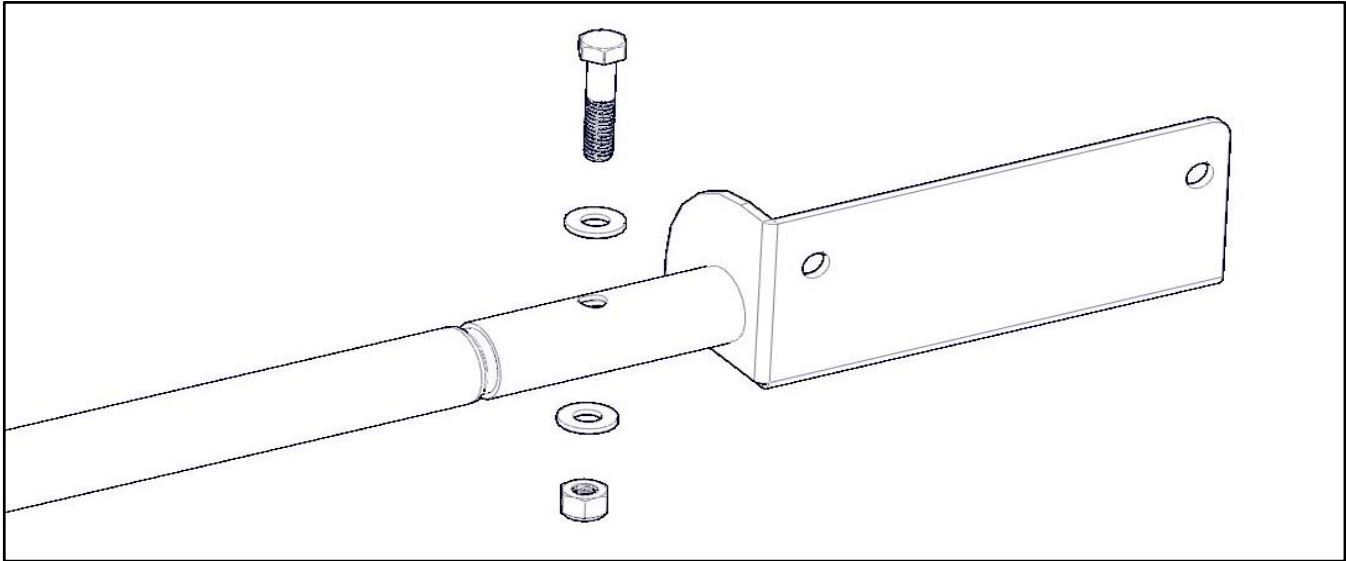

- Use .312" x 1.5" hex head, .312" flat washers and a .312" nyloc nut.

### B.

- Attach Support Tube(D&E) to the Ladder pan as shown using .312" x .625 hex head (8) with .312" lock washers(9) and .312" flat washers(6).
- Repeat at front and rear bow.

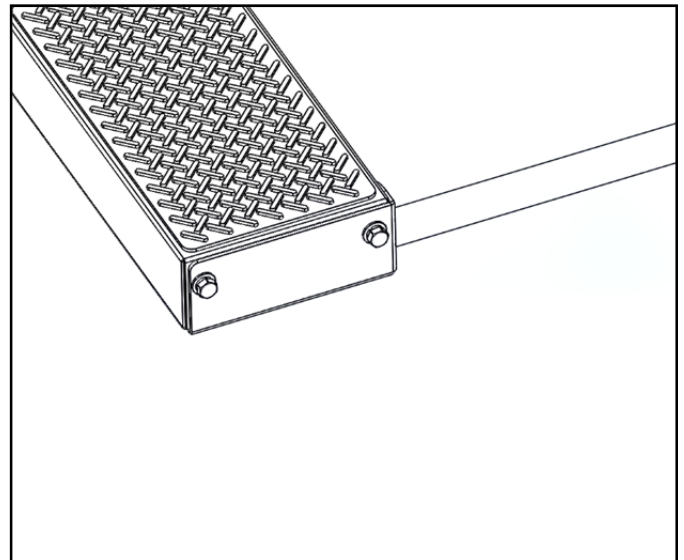
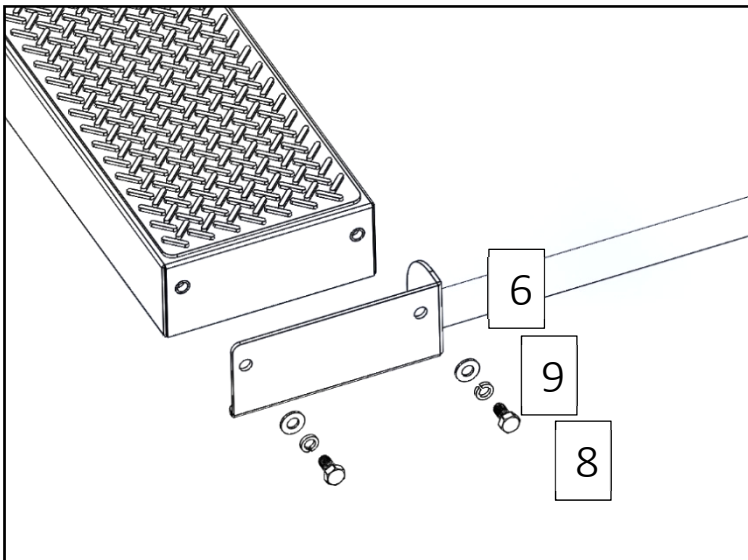

## Step 5 – Ladder Stops and Hooks

- On the front bow (A), remove 3/8"x3/4" bolt, 3/8" split lock washer and 3/8" flat washer from shown location and install Ladder Stop(I)

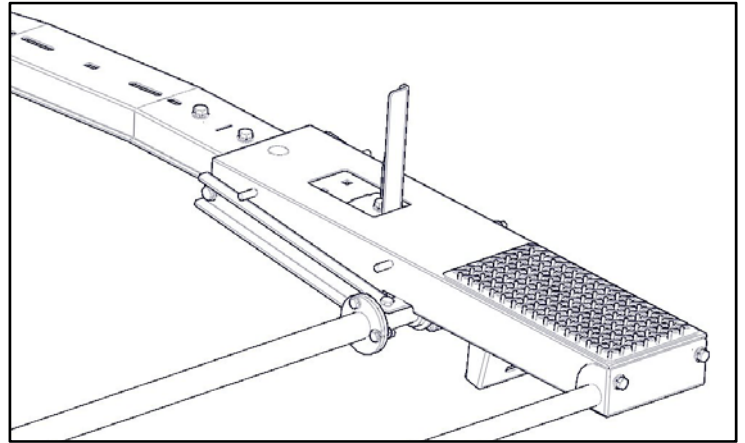
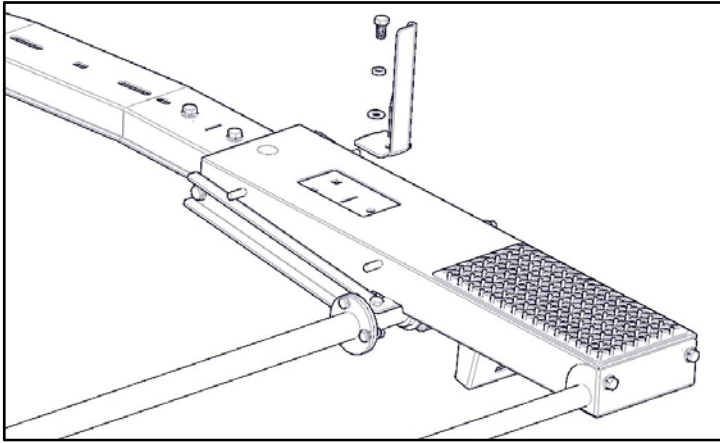

- Bolt Ladder Hook (H) to the lower position where the pem studs are installed. Use a .312 flat washer(6) and a .312 nyloc nut (10).
- Repeat on both sides of ladder hook (H).

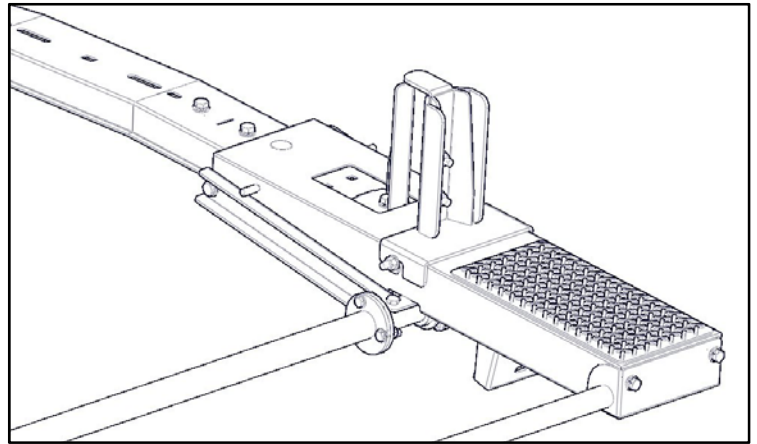
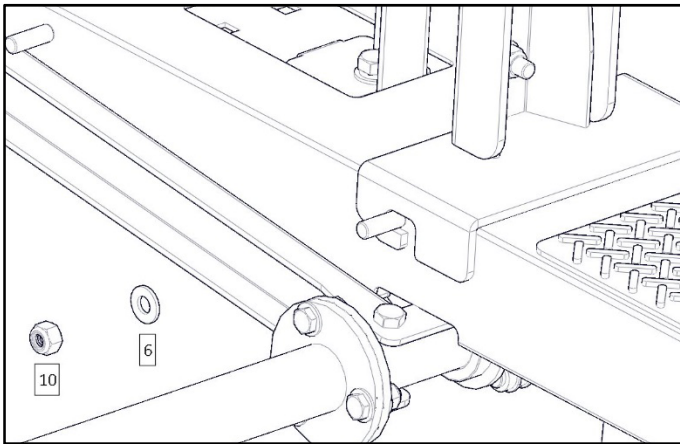

- If using an "Extension Ladder" put the Ladder Stop(I) at the same location on the Front & Rear Bow Assy.(A&B).

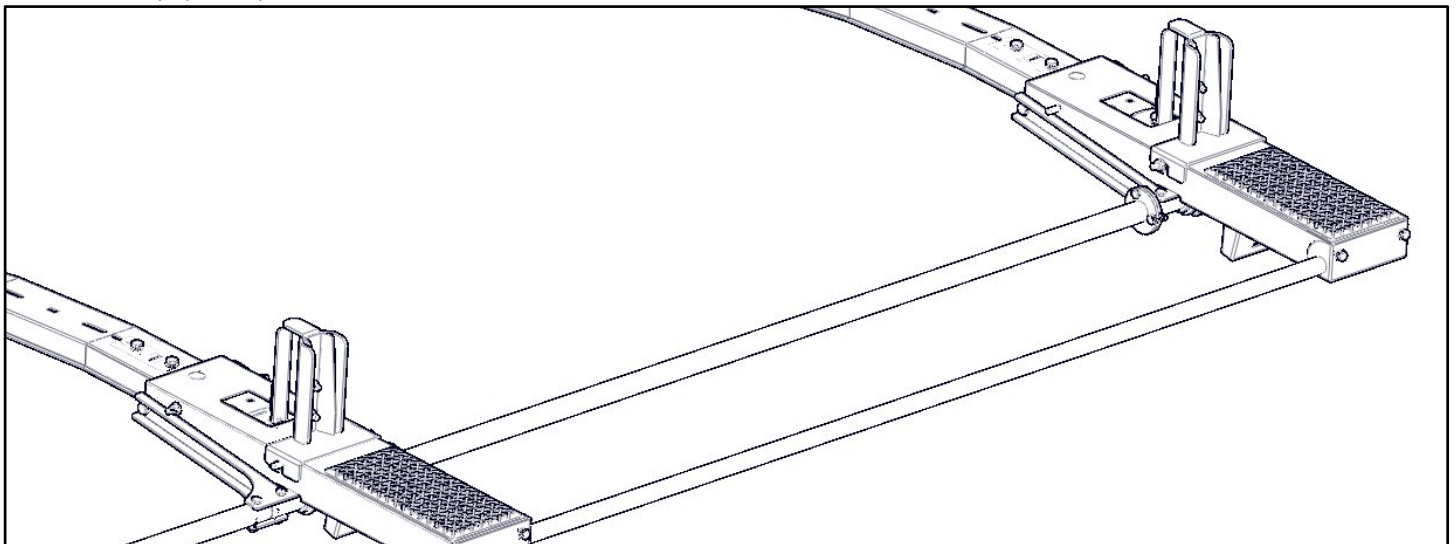

## Step Ladder Set-Up

- If installing for a “Step ladder”, The ladder hook (H) and the ladder stop (I) change positions on the rear bow.
- Both of these parts move higher up on the bow and are installed using the other pem studs.

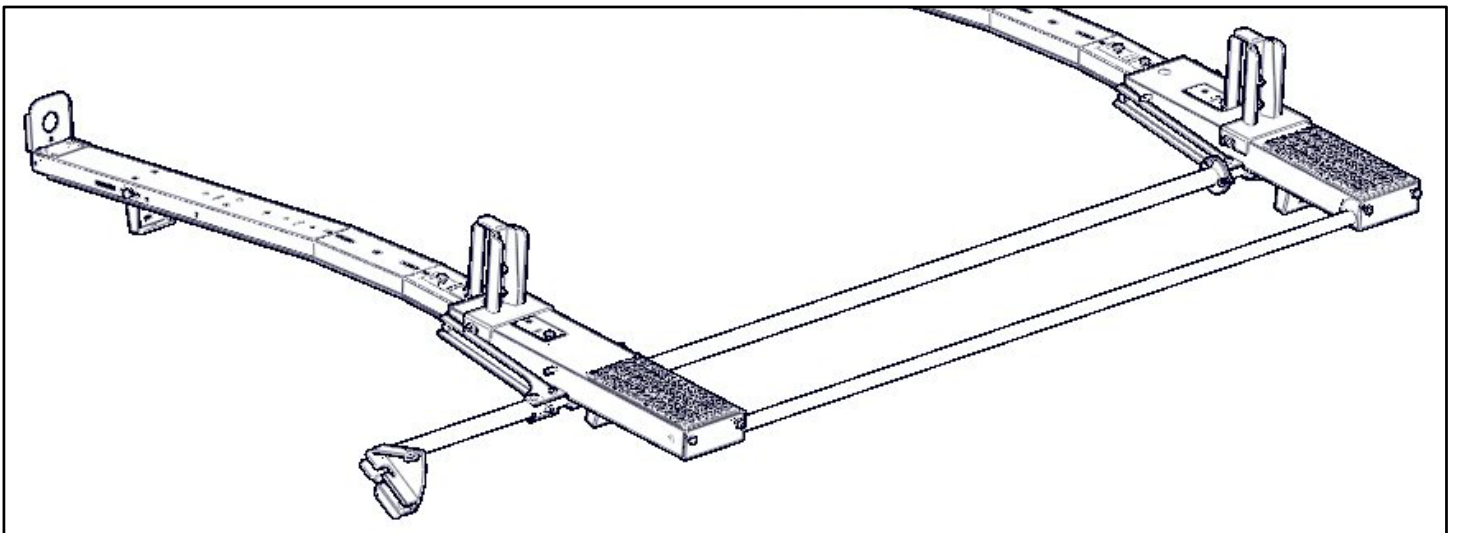
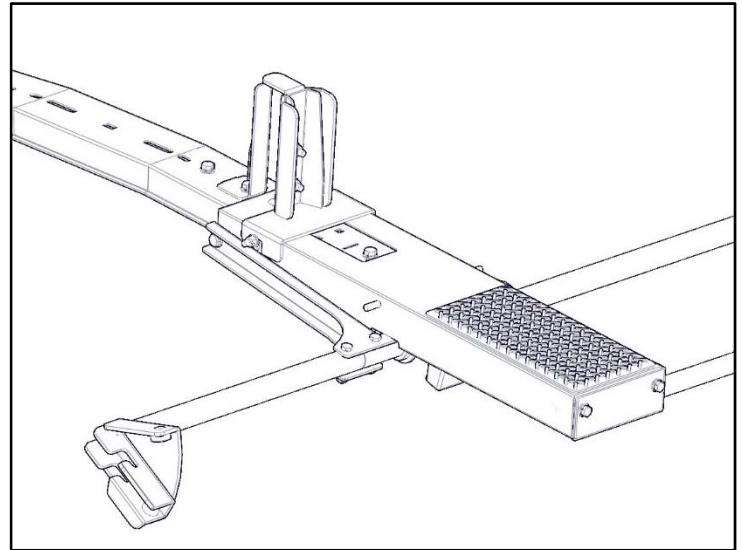
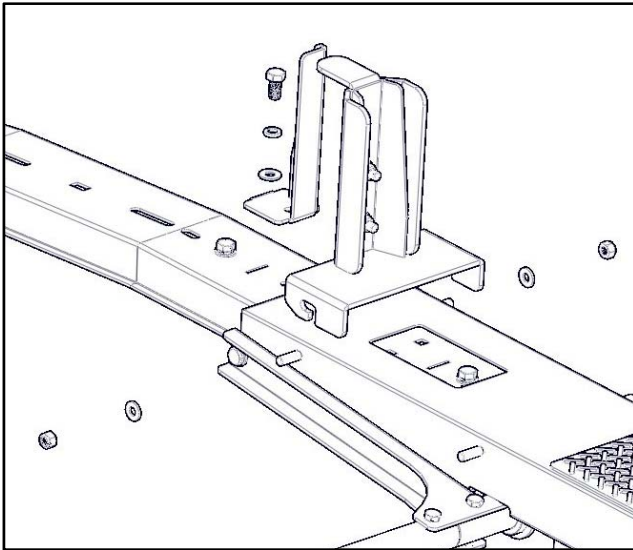

## Step 6 - LoadPlate

- Attach the Load Plates(J) on the driver side as shown using .312”x .75” carriage bolts(7) with .312” flat washers(6) and .312 nyloc nuts(10).

**\*\*You will NOT use these if you are installing a double drop down\*\***

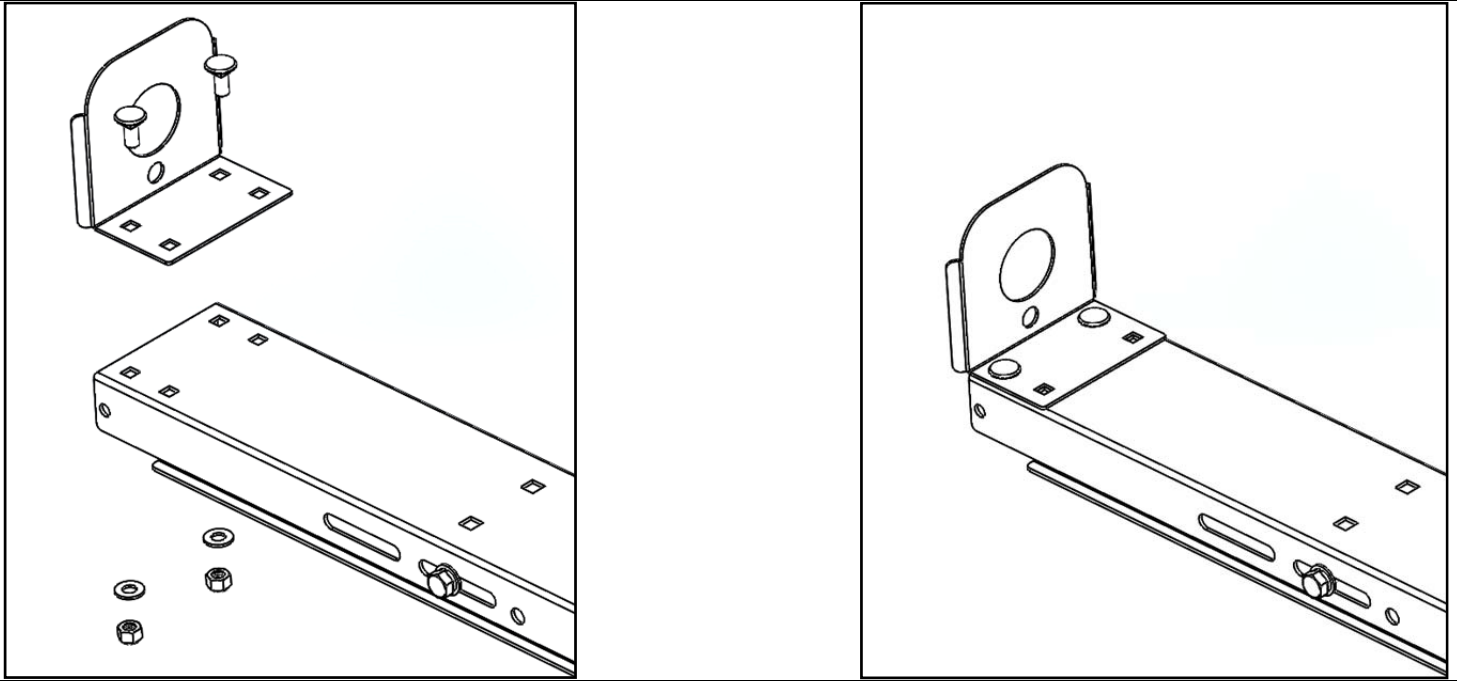

### Step 7 – Installing Rack

- If you built the rack on the bench you can now set the rack on the mounts as described in **Step 2.**

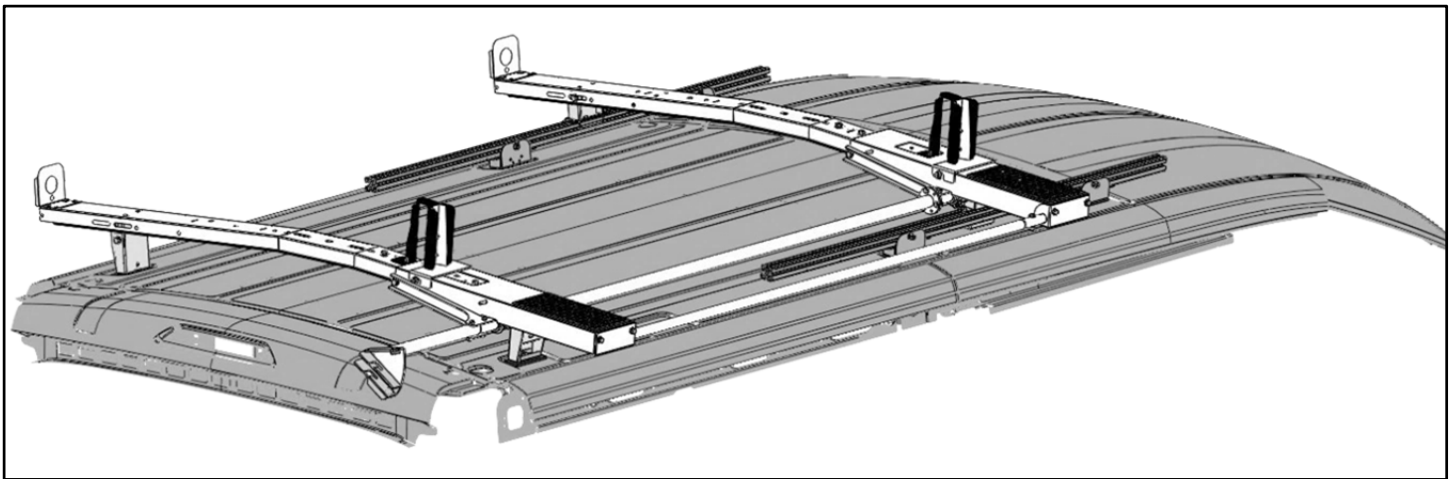

### Step 8 – Install Handle Bar holder

- Install handle bar holder clip from hardware kit to your preference. Most install at the rear of the van, on the backside of a shelving unit.
- Install clips using #10 hardware provided.

**GO BACK AND ENSURE ALL HARDWARE IS TIGHT**  
Your installation is now complete.