

KARGO MASTER[®]

WE PUT EVERYTHING WITHIN REACH.

Installation Guide

4081P Instructions

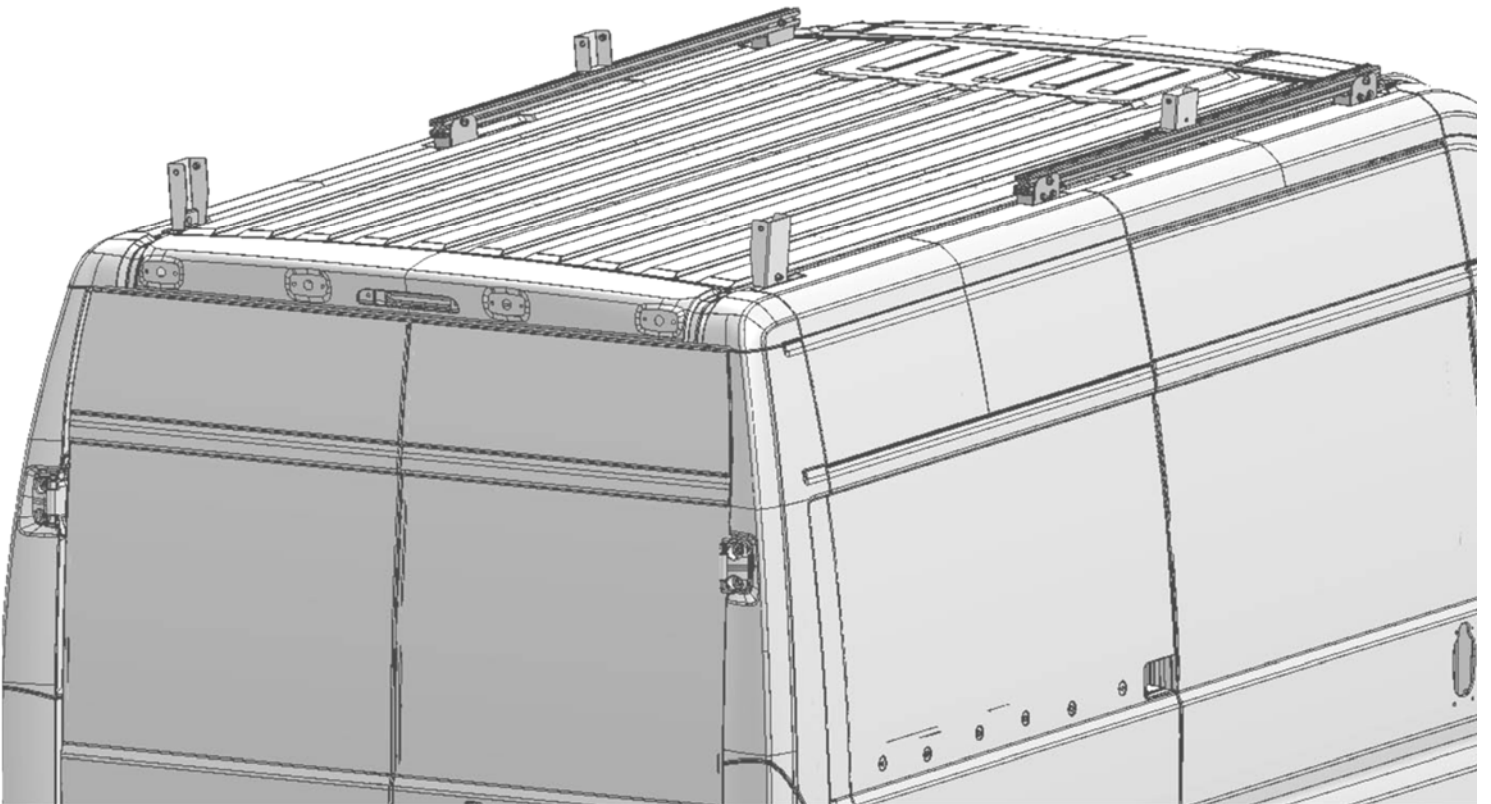

***PLEASE READ ALL INSTRUCTIONS AND WARNINGS PRIOR TO ASSEMBLING,
INSTALLING, AND USING THIS PRODUCT***

Warning



Always check for wires, fuel tanks and lines, brake lines and other important vehicle functionality items prior to drilling and installing all products.

Tools Needed

1/2" Socket and Wrench	7/16" Socket and Wrench
1/8" Allen Hex	Tape Measure

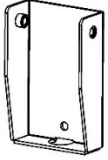
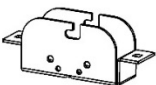
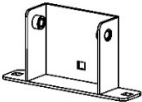

Table of Contents

Parts List	2
Hardware List	2-3
Step 1 – Prepare Mount Blocks	4
Step 2 – Find Mount Locations	4
Step 3 – Install Mount Blocks	5
Step 4 – Prepare Extrusion	6
Step 5 – Install Extrusion	6
Step 6 – Install Rear Foot	7
Step 7 – Install Mount Foot	8
Step 8 – Set Distance	9
Step 9 – Mount Feet to Rack	10



Before You Begin

- Read all instructions.
 - Follow assembly instructions found with the rack to assemble and install rack.
-





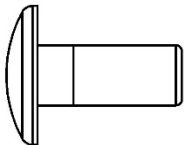
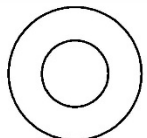

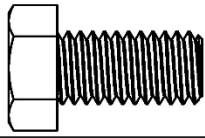
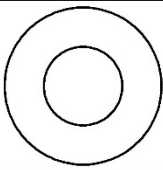
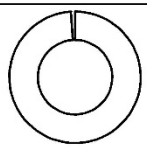
Parts

ITEM NO.		PART NUMBER	DESCRIPTION	QTY.
A		40818-20-001-R1	62in Extrusion	2
B		40818-25	Tall Foot Bracket	2
C		40818-20-003-R2	Raise Foot Bracket	4
D		40818-10	Short Foot Bracket	2
E		40818-20-007-R1	Rear Mount Bracket	2
		18-40818-FT-R1	Foot Bolt Kit	1
		18-40818-P	Promaster Bolt Kit	1

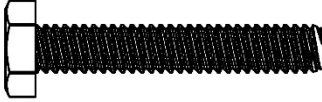
Hardware 18-40818-FT-R1

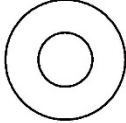
ITEM NO.	TO SCALE	DESCRIPTION	QTY.
1		5/16-18x3/4 Carriage Bolt	16
2		5/16 Flat Washer	16
3		5/16-18 Nyloc	16
4		3/8"-16 x 3/4" Hex Head	8
5		3/8" Flat Washer	8
6		3/8" Split Lock Washer	8

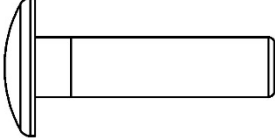
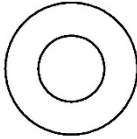
Hardware 18-40818-P

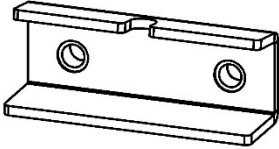
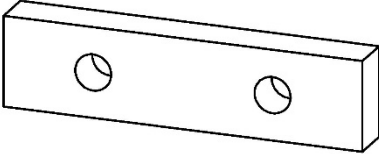
ITEM NO.	TO SCALE	DESCRIPTION	QTY.
7		1/4"-20 x 1-1/2" Hex Head	8
8		1/4" Split Lock Washer	8
9		1/4" Flat Washer	8
10		#10-32 x 1/2" Button Head	8
11		#10 lock washer	8
12		5/16"-18 x 3/4" Carriage Bolt	2
13		5/16" Flat Washer	2
14		5/16"-18 Nyloc	2
15		40818-23 SCALE 1:2	4
16		40818-20-006-R1	4

Step 1 – Prepare Mount Blocks

- Attach spacer block inside mount block using #10-32 x .50 BHCS and #10 split lock washers as shown.
- Repeat on all four blocks.
- TIGHTEN

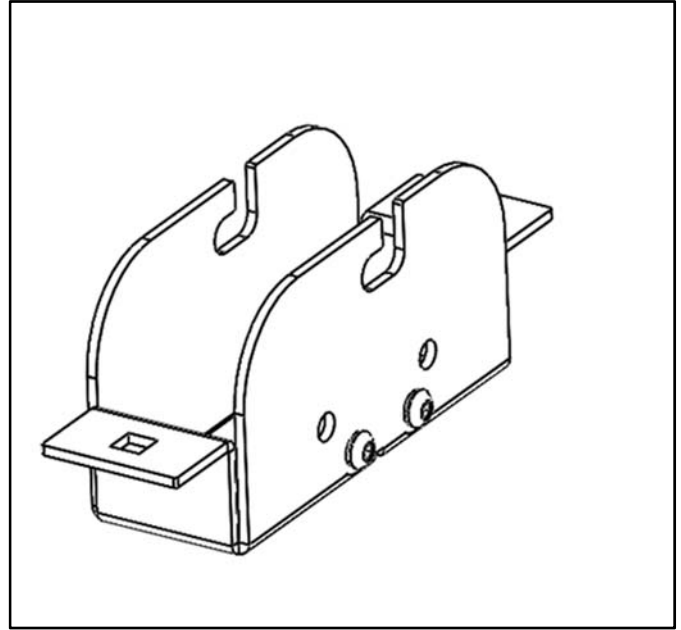
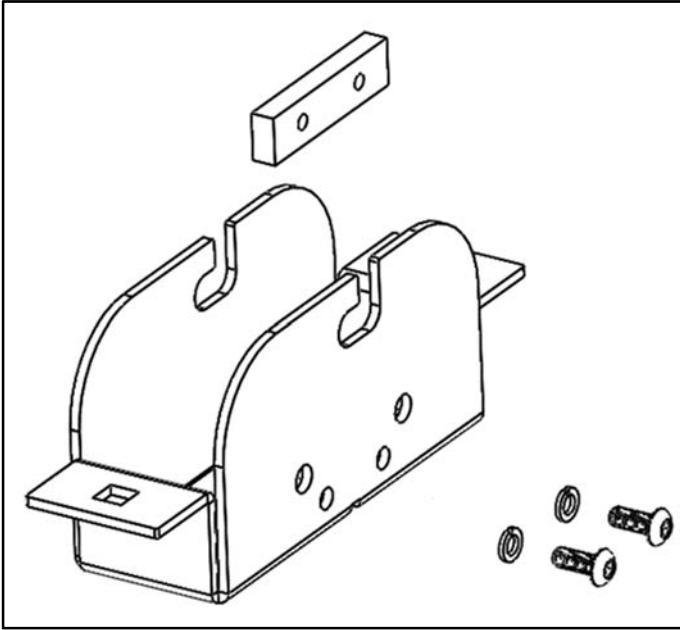

Step 2 – Find Mount Locations on Roof of Van

- Locate the front two mounting locations on each side of van. This is where the mounting blocks will be mounted.

****This picture shows on a 136" wheel base, high roof van****

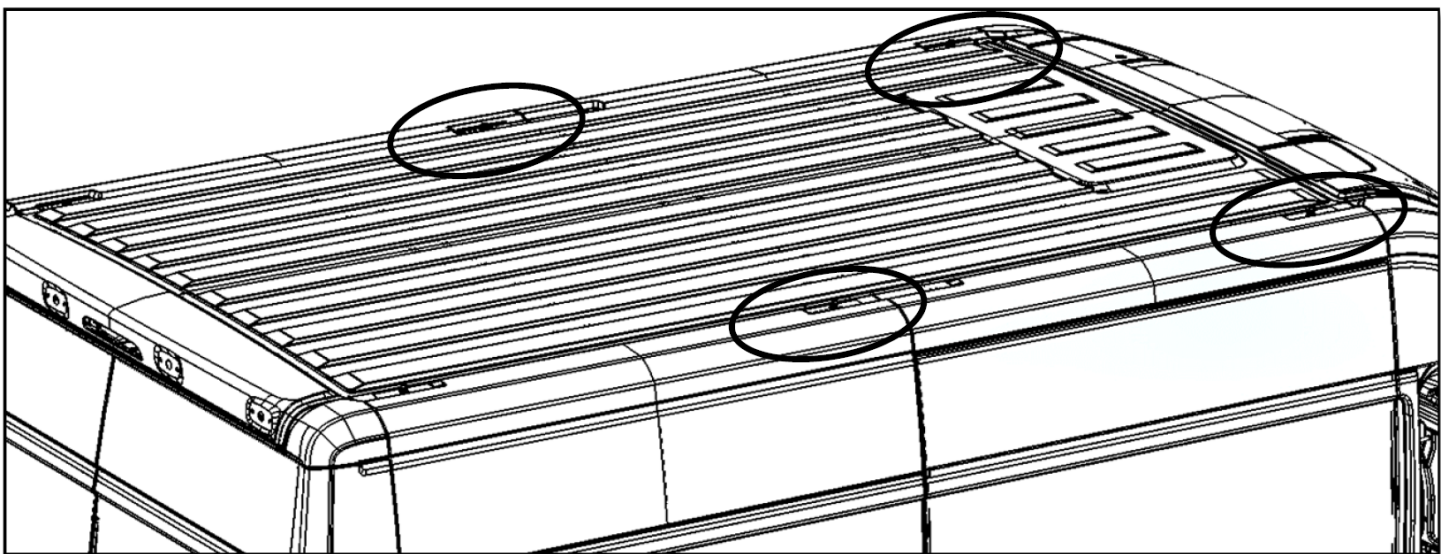

Step 3 – Install Mount Block

- Set mount block assembly over the “T” stud extruding from the top of the roof.
- Insert mount clip as so the slot goes under the head of the “T” stud to mount tight.
- Bolt through the mount assembly and into the mount bracket using two 1/4" x 1-1/2" hex bolt, two 1/4" split lock washers and two 1/4" flat washers as shown.
- DO NOT OVER TIGHTEN
- Repeat in all corners for a total of 4x.

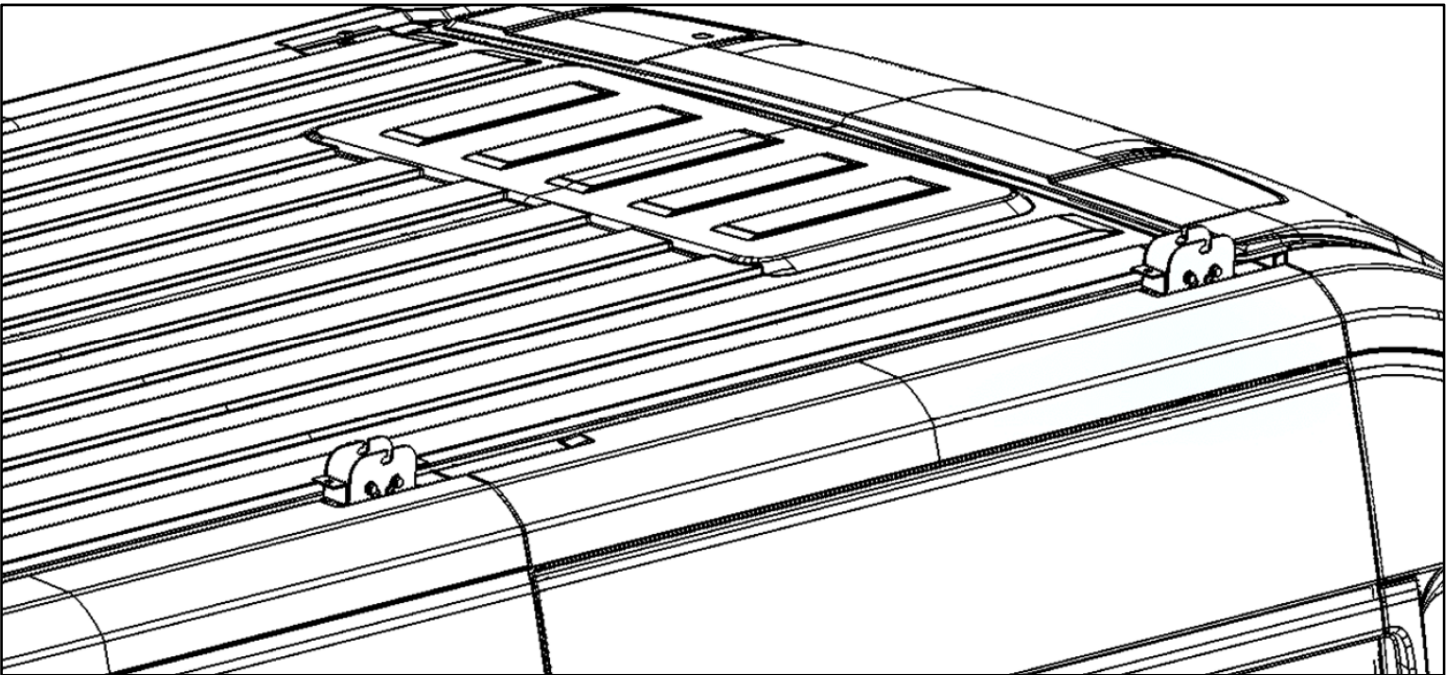
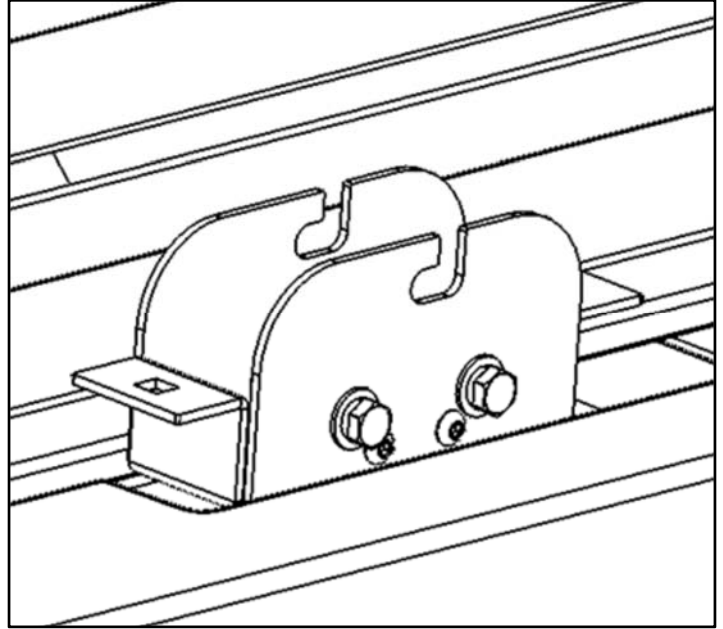
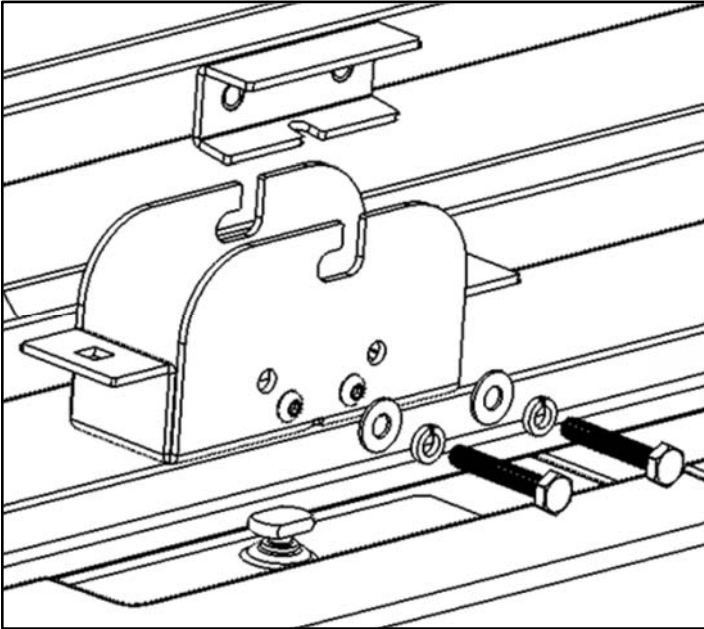

Step 4 – Prepare Extrusion

- Slide two 5/16" x 3/4" carriage bolt into opposite slots of extrusion. These carriage bolts are in the foot mount kit (18-40818-FT-R1).
- Repeat on each rail, for a total of 8 carriage bolts on two rails.

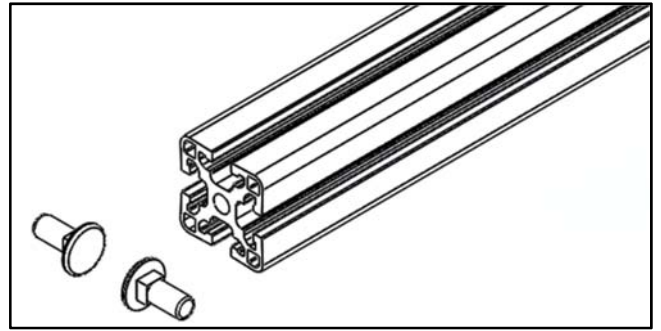

Step 5 – Install Extrusion

- Place mount rail with carriage bolts onto the mount blocks that were installed in step 3.
- Line the carriage bolts up in the slot of the mount blocks.
- Bolt using previous carriage bolt, 5/16" flat washer and a 5/16" nyloc nut.
- Snug Tighten, But allow movement.

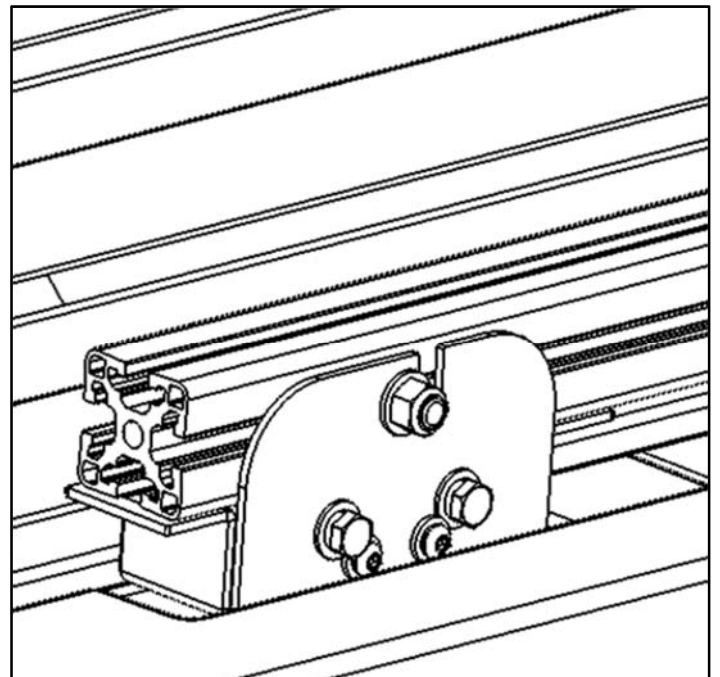
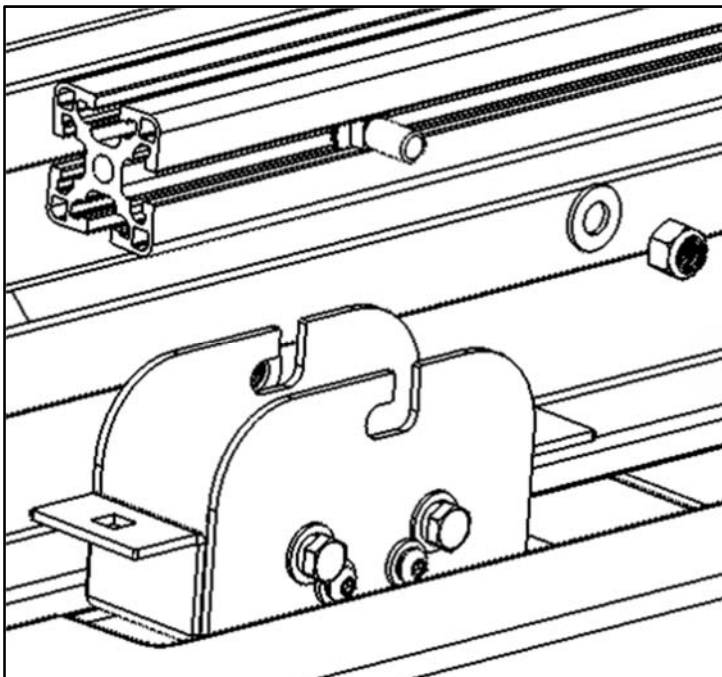
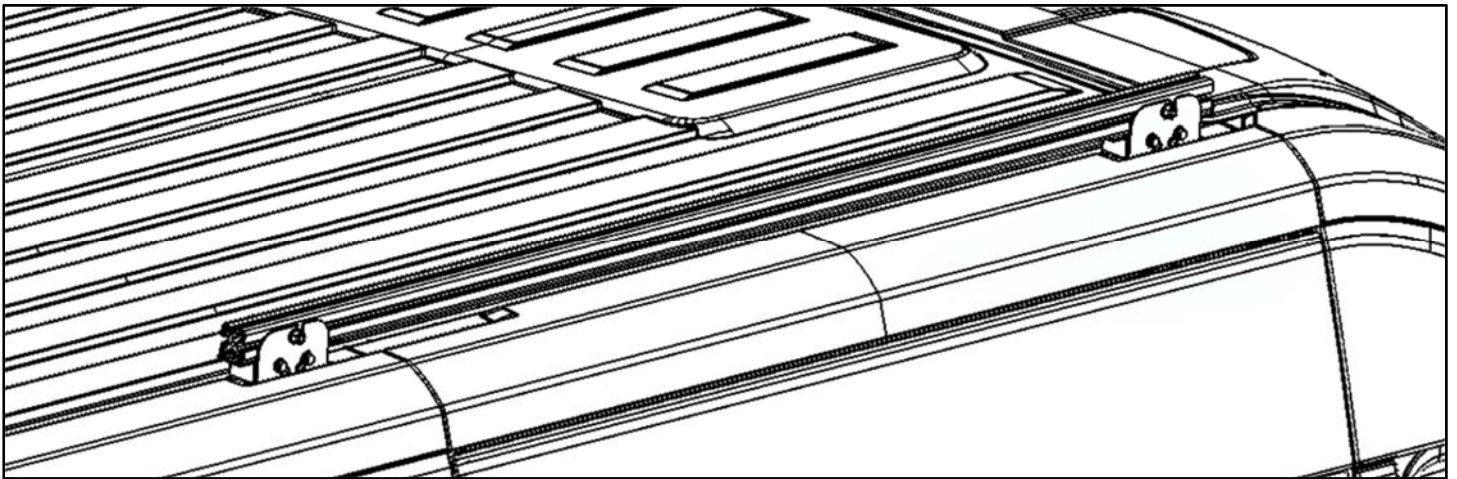

Step 6 – Install Rear Foot

- Place rear foot over the “T” stud at the rear of the roof.
- Insert mount clip as so the slot goes under the head of the “T” stud to mount tight.
- Bolt through the mount bracket and the rear foot using a 5/16” x 1-1/4” carriage bolt, a 5/16” flat washer and a 5/16” nyloc nut.
- DO NOT OVER TIGHTEN. Leave some room for adjustability until rack in on vehicle.
- Repeat on other side.

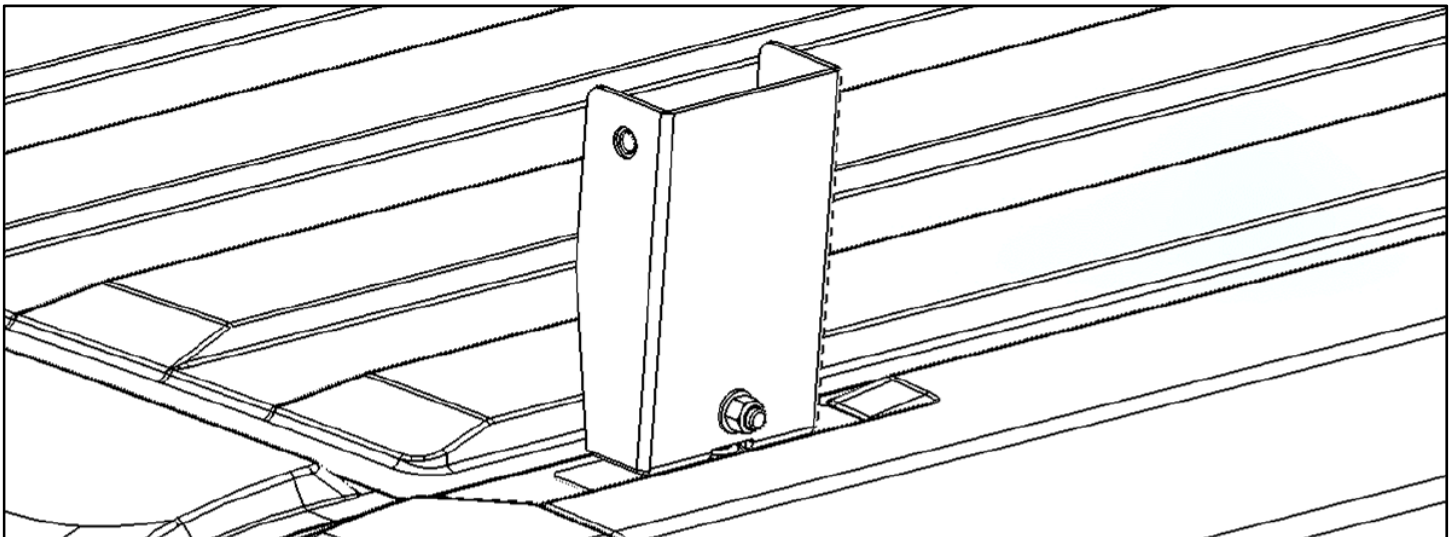
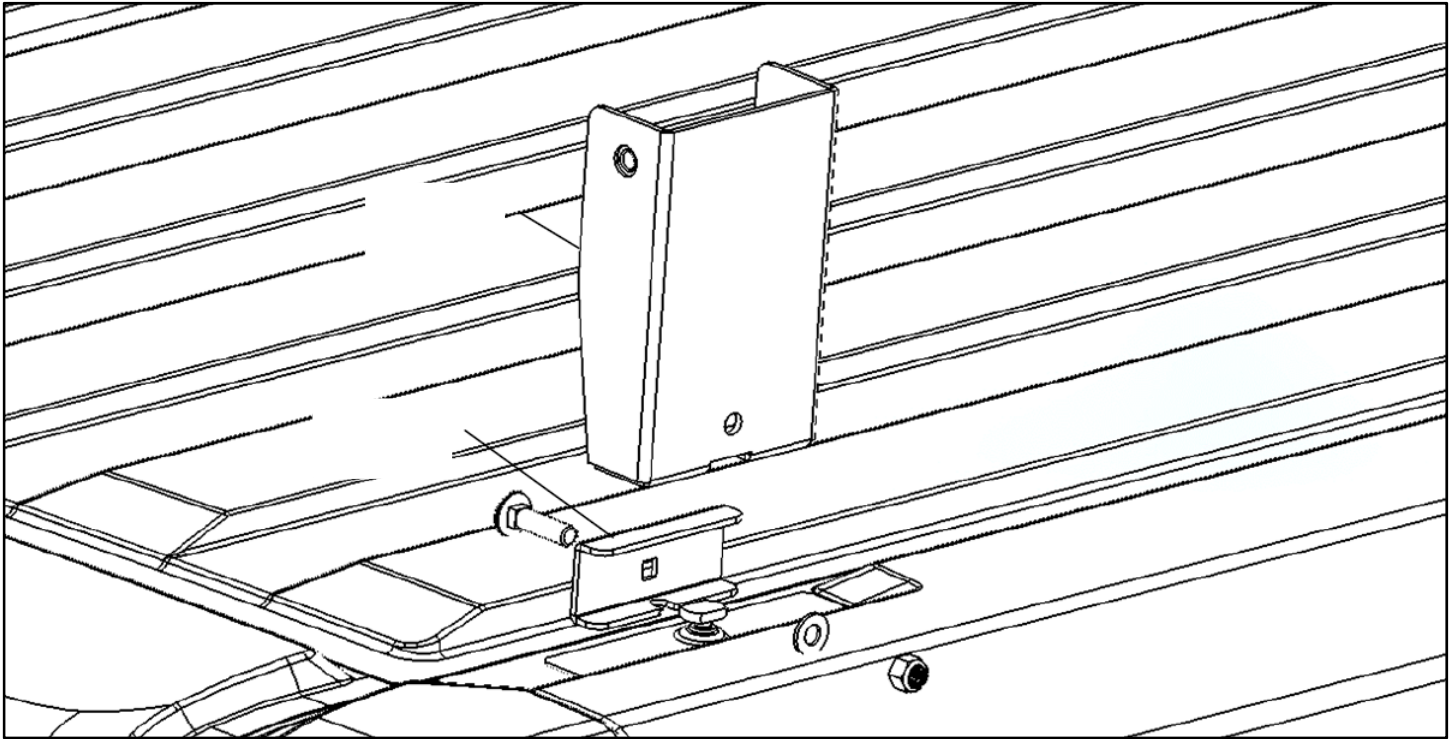

Step 7 – Install Mount Foot

- Slide two 5/16" x 3/4" carriage bolts into the top slot of the mounted extrusion.
- Place mount foot over carriage bolts.
- Bolt together using carriage bolt, 5/16" flat washer and 5/16" nyloc nut.
- DO NOT TIGHTEN.

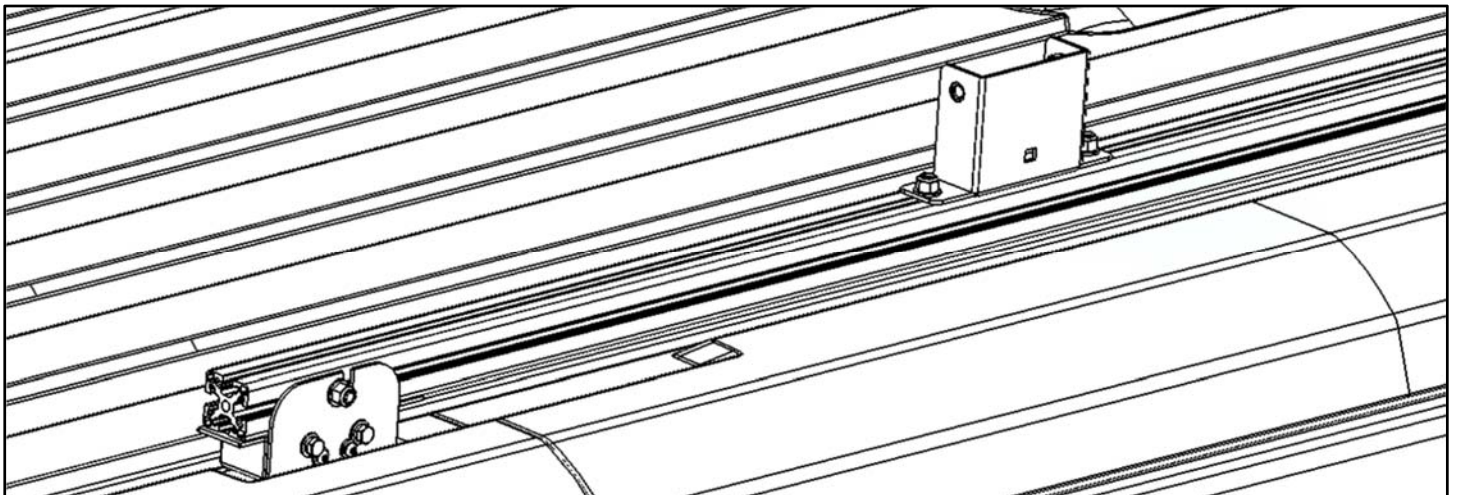
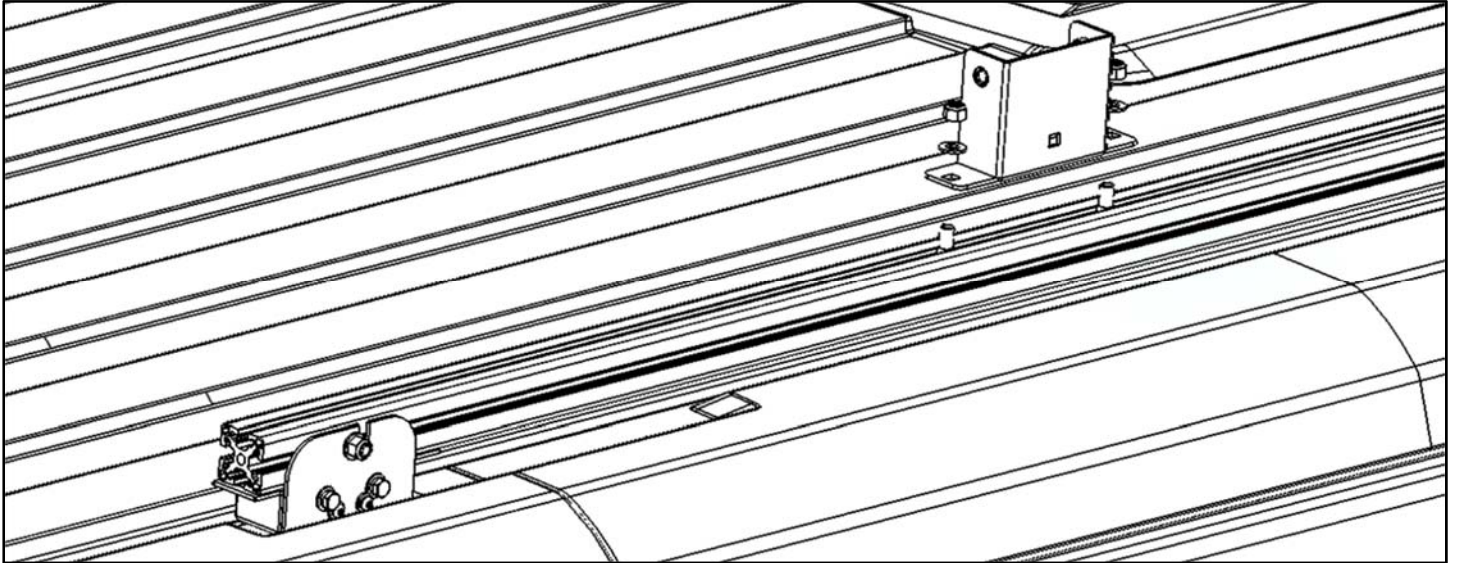

Step 8 – Set Distance

- Set center to center distance from rear foot at 71.5" or 96". If using the extension, set at 96".

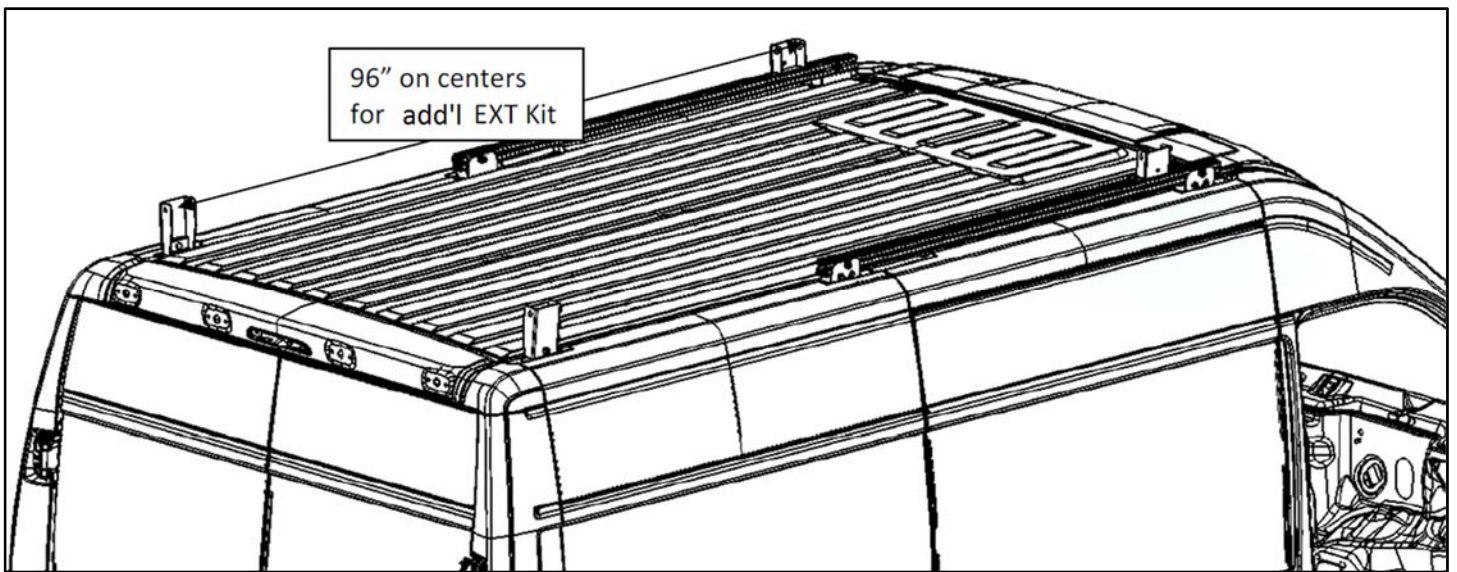
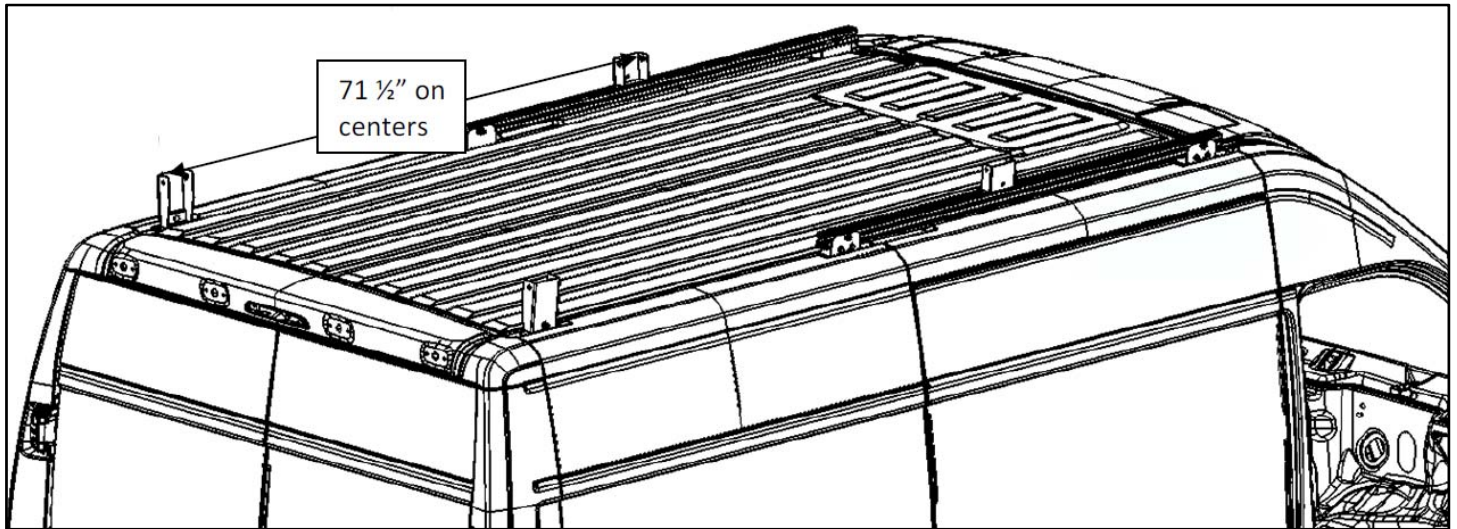

Step 9 – Mount Feet to Rack

- Determine if the rack is being assembled on the vehicle or if the rack will be assembled off the vehicle and set on top of installed feet.
- In either case, bolt bows to feet using 3/8" -16 x 3/4" hex head, a 3/8" lock washer and a 3/8" flat washer in order shown.

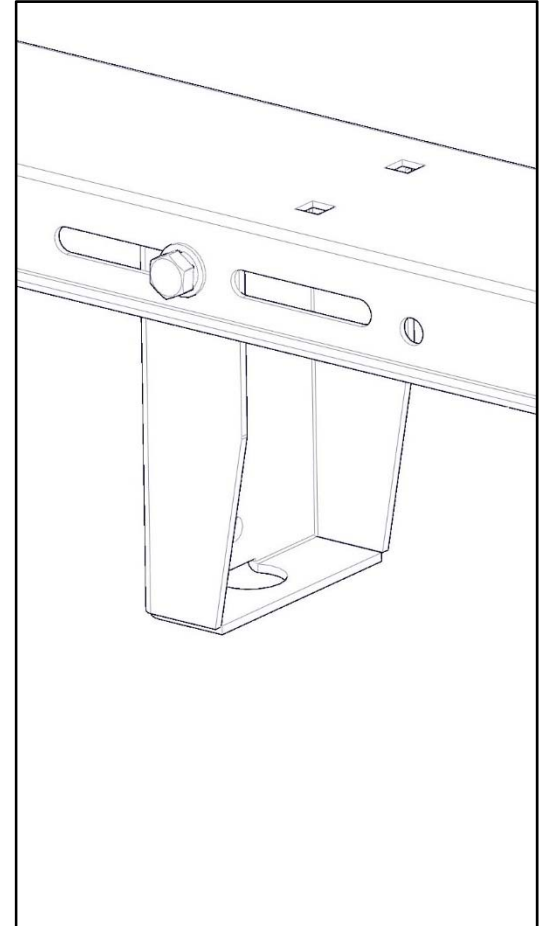
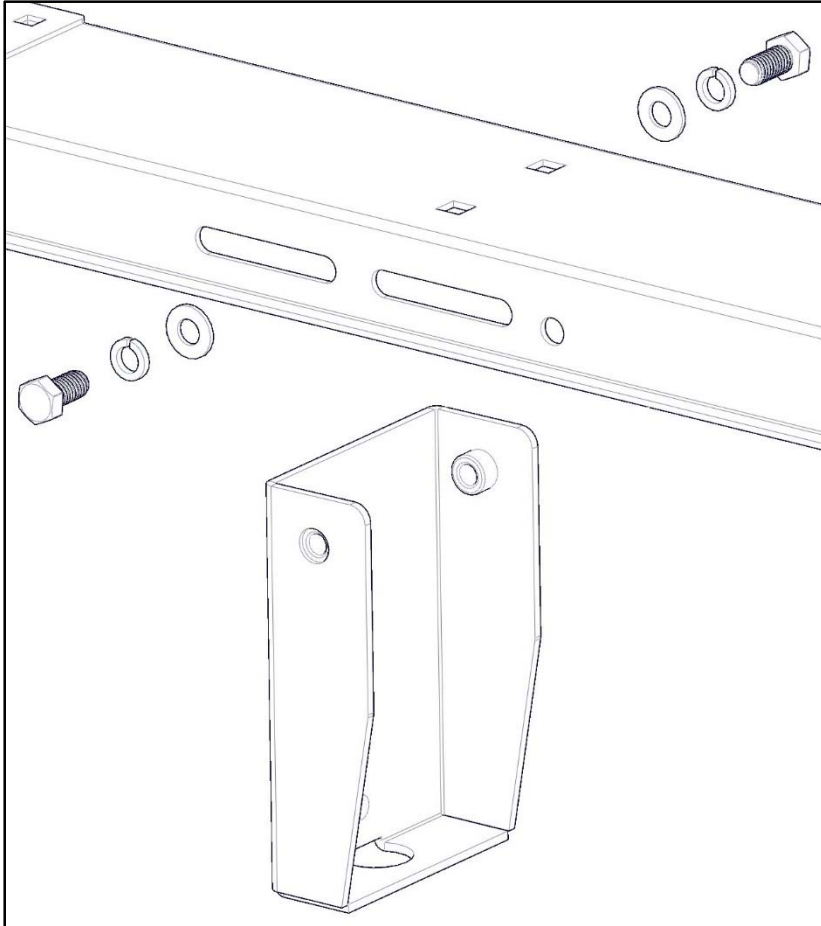

GO BACK AND ENSURE ALL HARDWARE IS TIGHT
Your installation is now complete.

KARGO MASTER®

WE PUT EVERYTHING WITHIN REACH.

Installation Guide

4099H

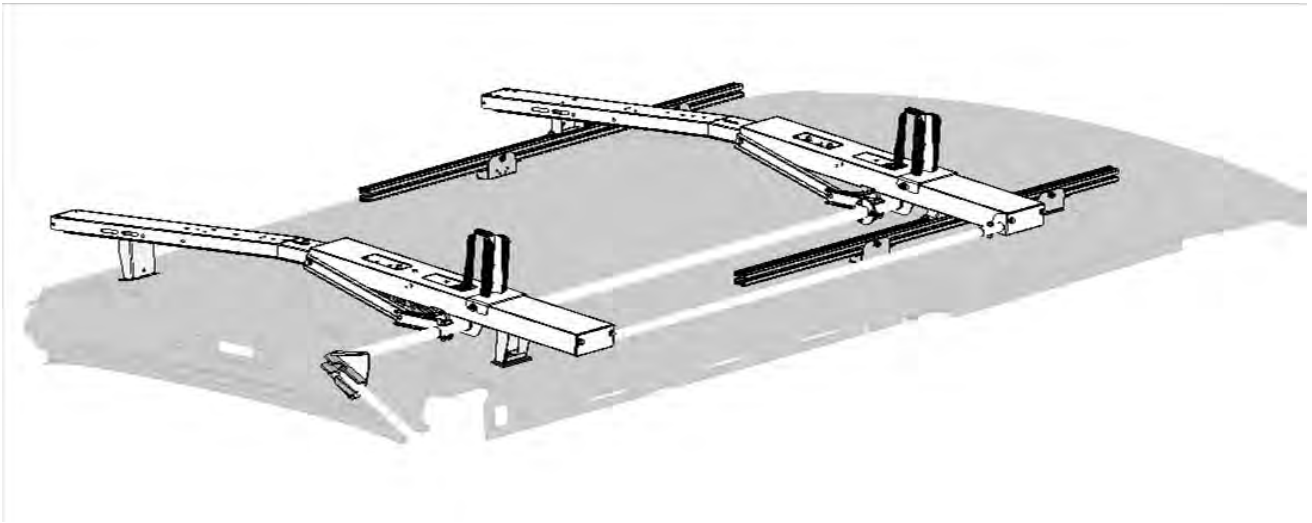

***PLEASE READ ALL INSTRUCTIONS AND WARNINGS PRIOR TO ASSEMBLING,
INSTALLING, AND USING THIS PRODUCT***

Warning



Always check for wires, fuel tanks and lines, brake lines and other important vehicle functionality items prior to drilling and installing all products.

Tools Needed

1/2" Wrench and Socket	7/16" Wrench and Socket
9/16" Wrench and Socket	Tape Measure
Phillips Drive	

Table of Contents

Parts List 2

Hardware List 3

Step 1 Install Actuator 4

Step 2 Install Front and Rear Bow Assembly 5-6

Step 3 Torque Tube 6-7

Step 4 Ladder Pan Support 8

Step 5 Ladder Stops and Hooks 9





Step 6 Install Rack 10

Step 7 Install handle bar clip 11



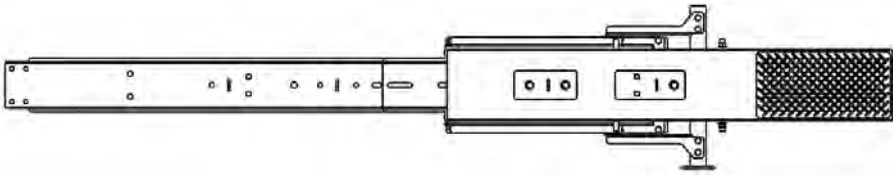
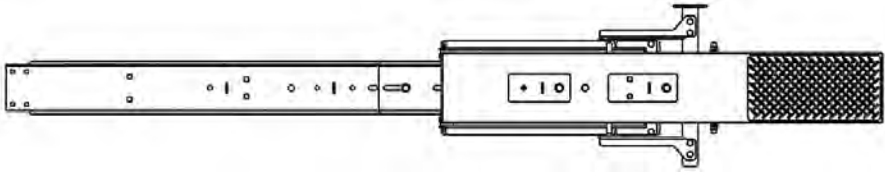
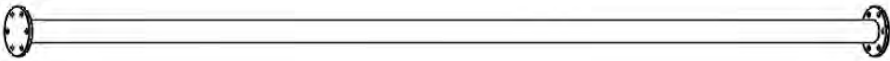
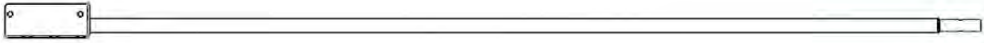
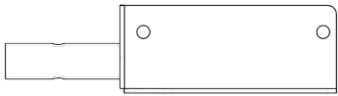
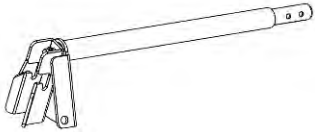

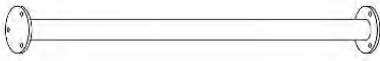
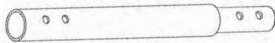
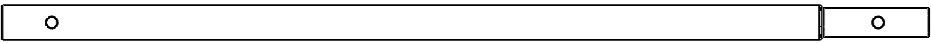

Before You Begin

- Read all instructions.

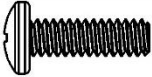
Parts

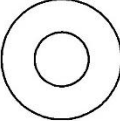
	4099H PARTS	DESCRIPTION	QTY
A		Front Bow Assembly	1
B		Rear Bow Assembly	1
C		Torque Tube	1
D		Support Tube	1
E		Support Tube End	1
F		Actuator	1
G		Removable Handle	1
H		Ladder Hook	2
I		Ladder Stop	2
J		Torque Tube Extender	1
K		Handle Extender	
L		Support Tube Extender	1
		HARDWARE	1

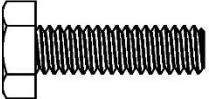
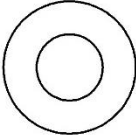
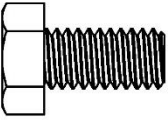
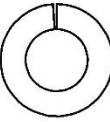
Hardware

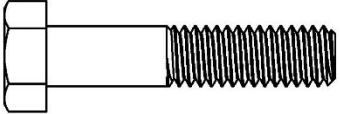
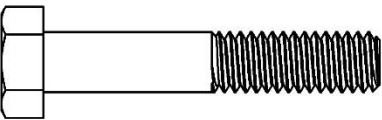
ITEM NO.	TO SCALE	DESCRIPTION	QTY.
1		10-24 x .625 PH Phillips Drive	2
2		10-24 Nyloc Nut	2
3		.25 flat washer	18
4		.25-20 NYLOC NUT	9
5		.25-20 x .875 HH	9
6		.312 Flat Washer	10
7		.312-18 x .625 HH	4
8		.312 Split Lock Washer	4
9		.312-18 Nyloc Nut	3
10		.312-18 x 1.50 HH	1
11		.312-18 x 1.75 HH	2
12		Handle Bar Holder	2
13		E6000	1

Step 1 – Install Actuator

- This can be done on or off the van.
- Remove existing hardware from the Rear Bow Assy. (B) as shown
- Keep Hardware, This will be re-used.
- Install the Actuator (F) with the “triangle” opening towards the end of the bow.
- Be sure to put E6000 into tube swedge and around the bolt holes.

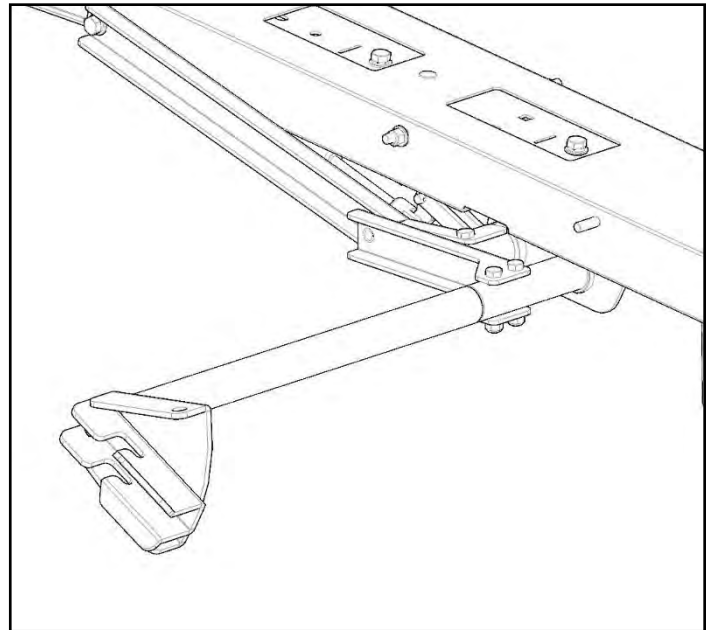
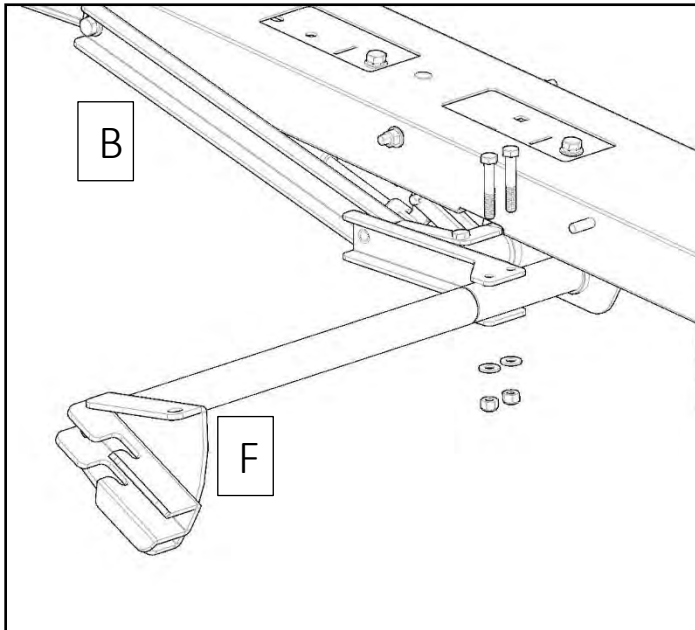

If installing on a High Roof Extended Transit, the Handle Extension (L) will be used. This extension goes inbetween the rear bow (B) and the actuator (F).

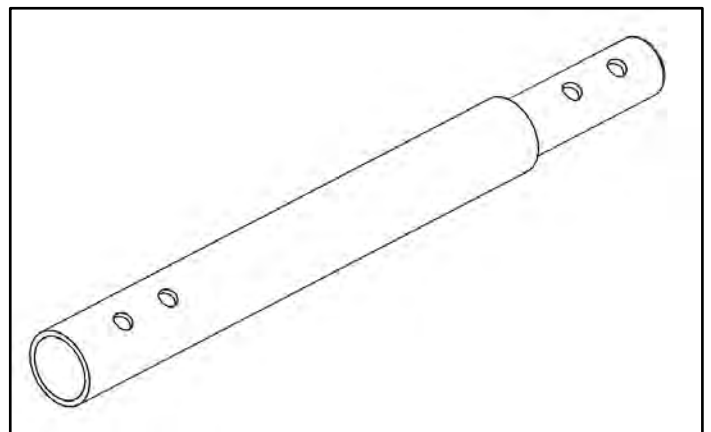

Step 2 – Install Front and Rear Bow

If you have a lift you can skip this step and continue building the rack on a bench

A. Rear Bow

- Set Rear Bow Assy. (B) on rear mounting feet as shown.

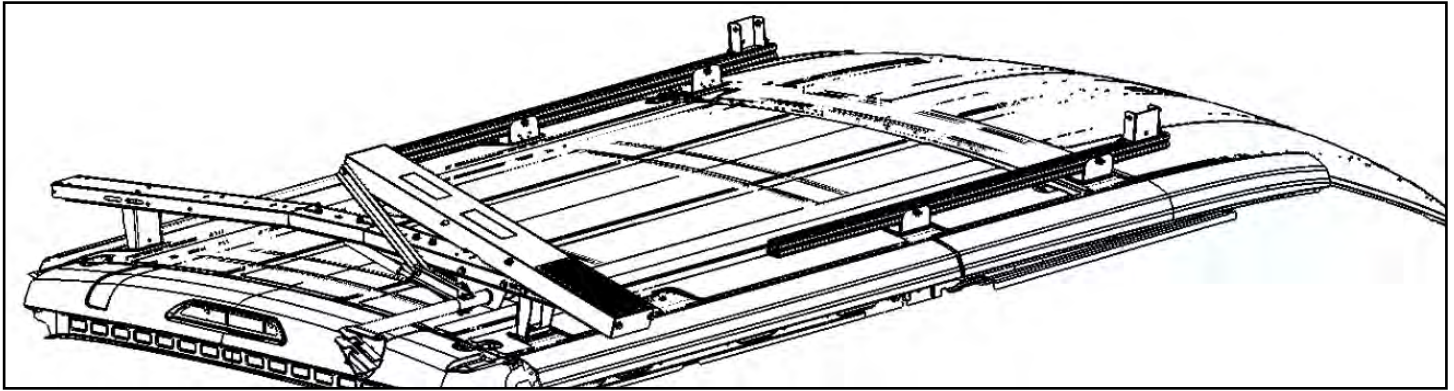

- Place a foam block from the packaging to hold the bow in the up position in order to access the mounting slots.
- Insert .375" x .75" hex head bolts (13) with .375" flat washer (12) and .375" lock washer (11) as shown.
- Leave loose until the the rack is assembled.
- Repeat on other side of bow.

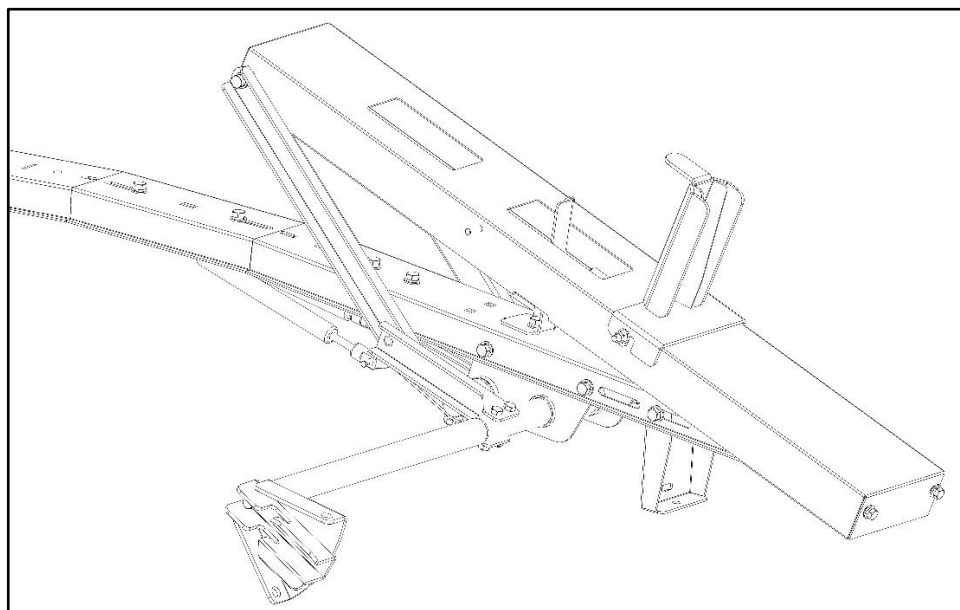
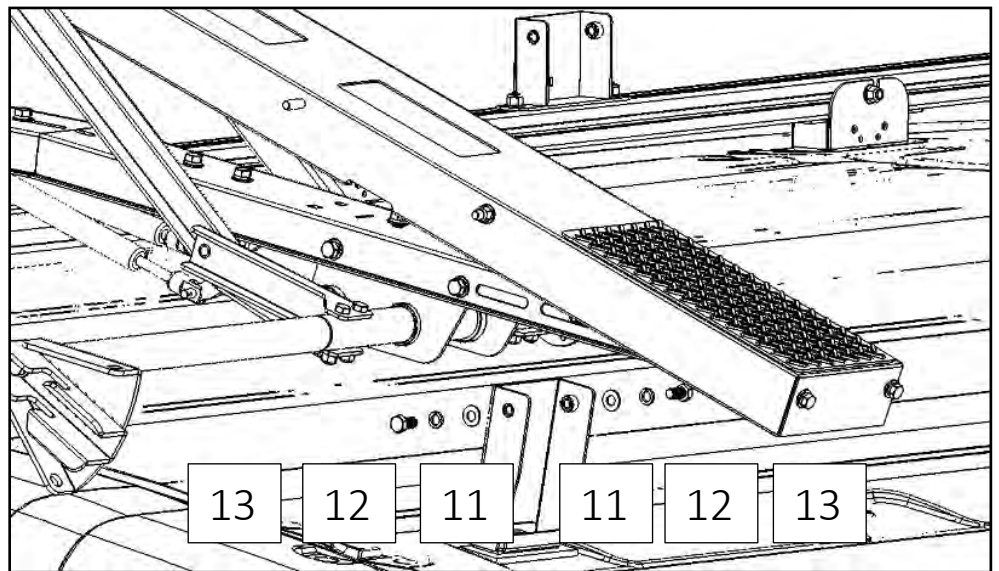

B. Front Bow

- Repeat the process for the front bow (A).

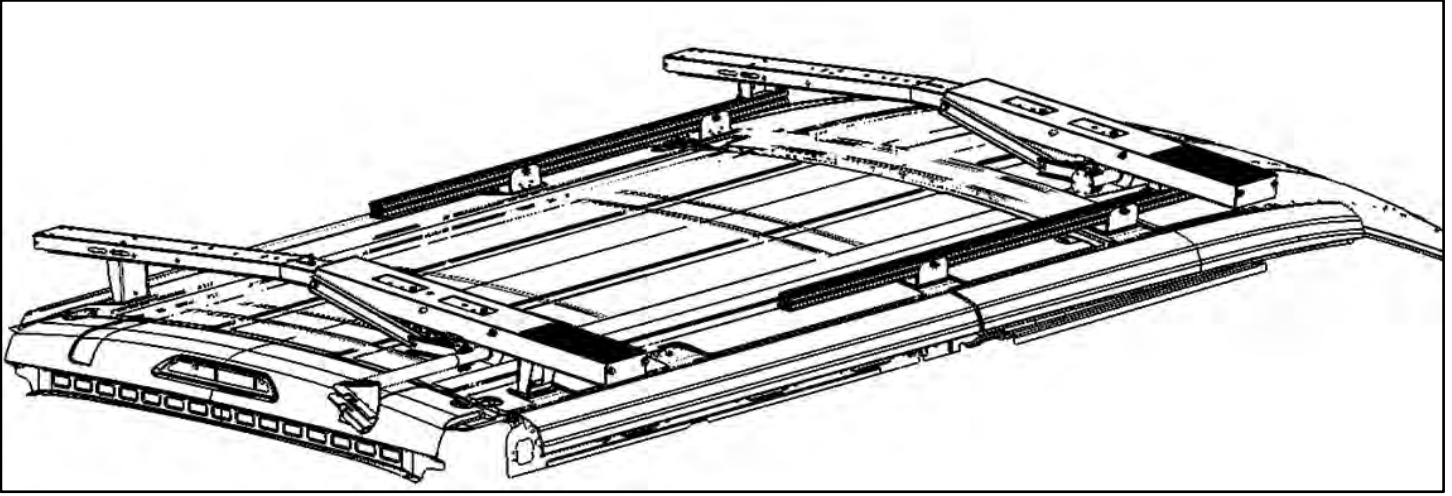

Step 3 – Torque Tube Installation

****BE SURE THE BOTH FRONT AND REAR LADDER PANS ARE ALL THE WAY DOWN ON THE BOWS WHILE TIGHTENING****

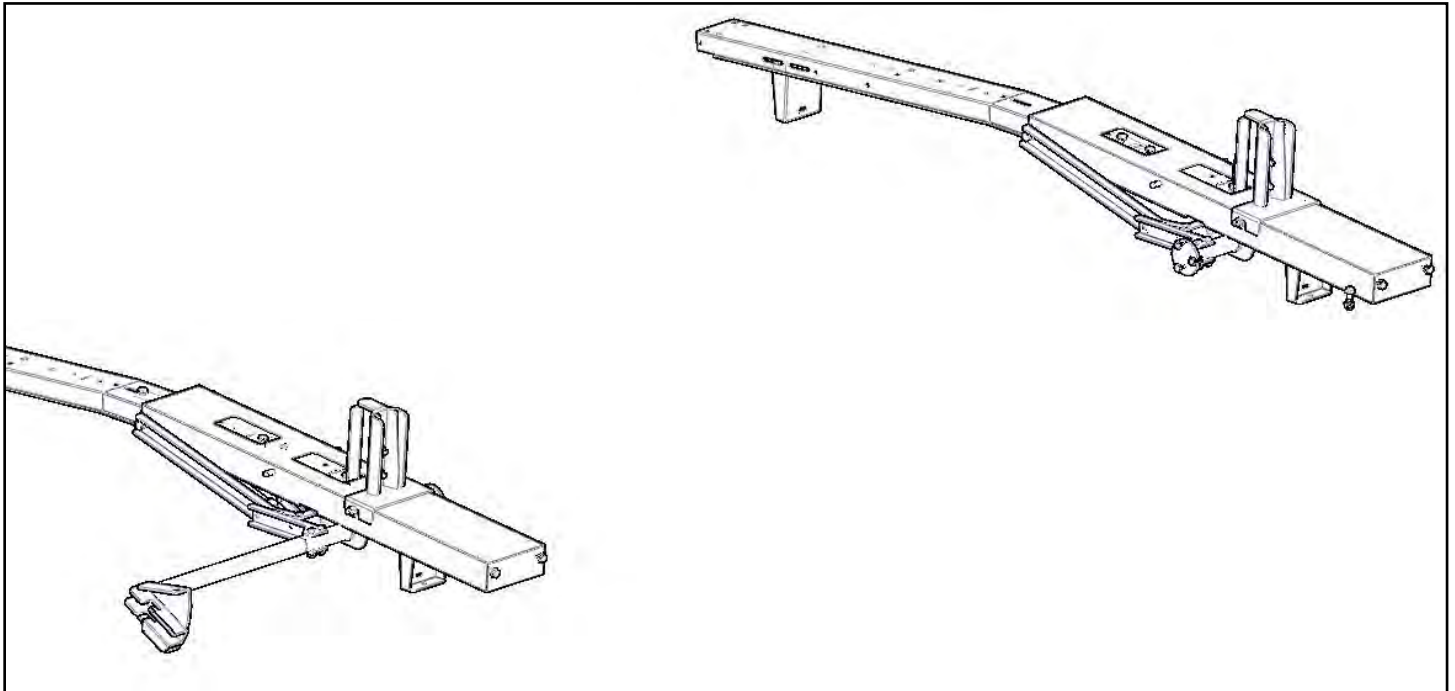

- Bolt Torque Tube(C) to Rear Bow Assy(B) using three .25" x .875" hex head bolts (5) six .25" flat washers(3) and three .25" nyloc nuts(4).

****You may want to put a foam packing block under the front of torque tube (C) to make it level while tightening.****

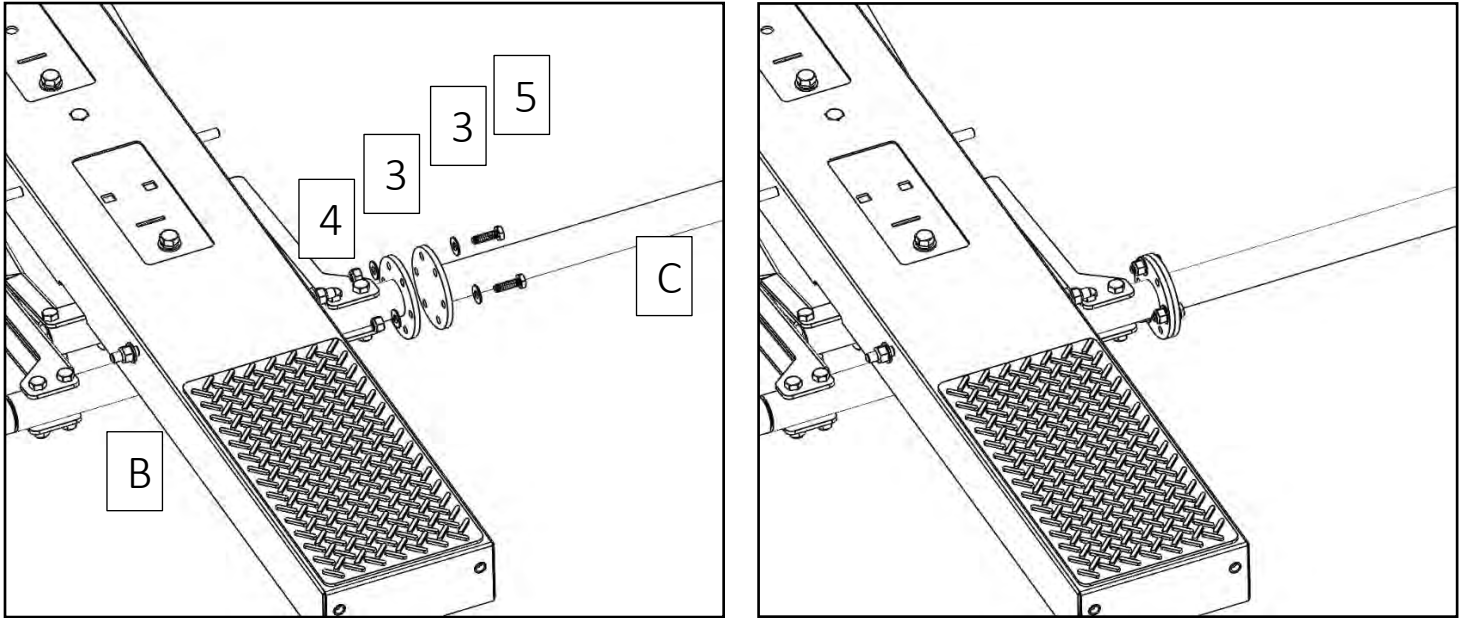

- Repeat process to bolt to the front bow assembly(A).

****If installing on a High Roof Extended Transit, the Torque Tube Extension (K) will be used****
This extension goes inbetween the torque tube (C) and the front bow (A)

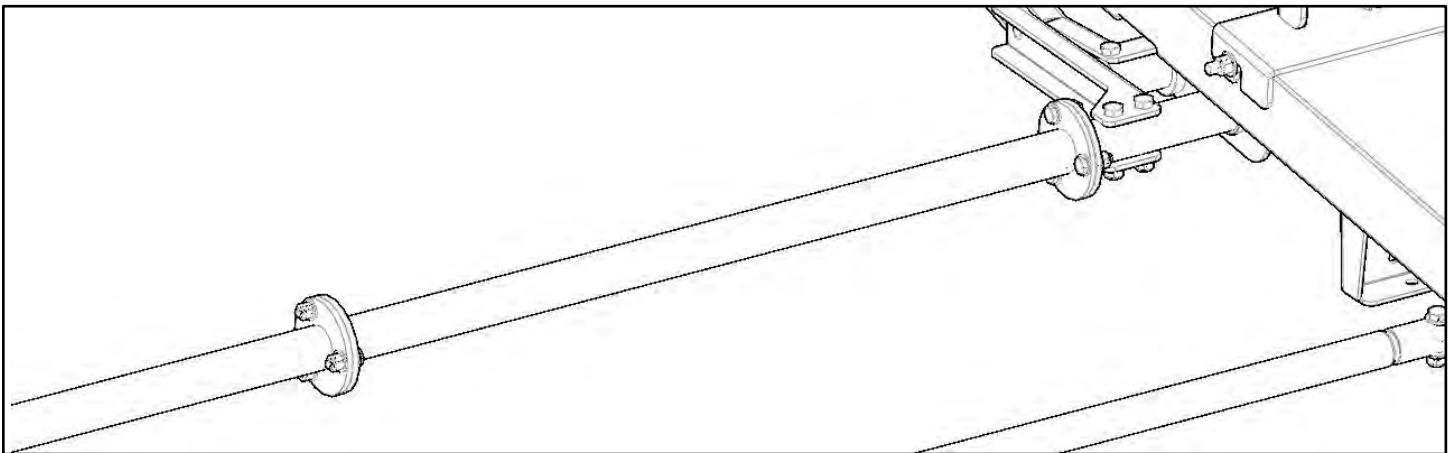

Step 4 – Ladder Pan Support

A.

- Assemble Support Tube(D&E). Put E6000(13) into tube swedge and around the bolt holes to prevent water from getting into tubes.

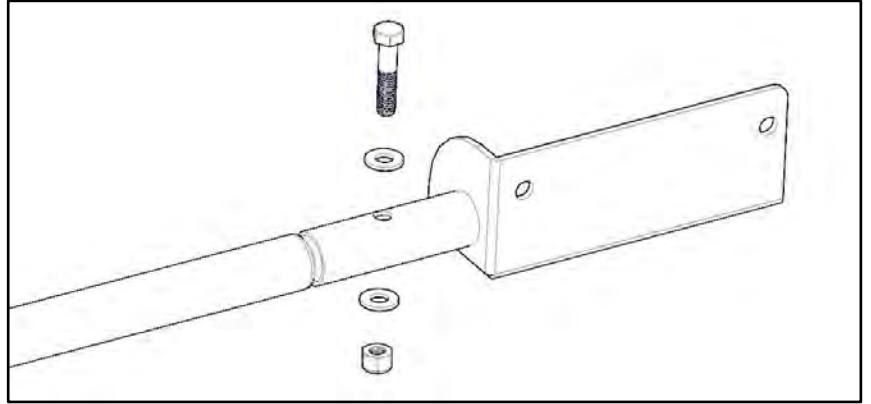

****If installing on a High Roof Extended Transit, the support tube extension (L) will be used****
This extension goes inbetween the support tube (D) and the support tube end (E)

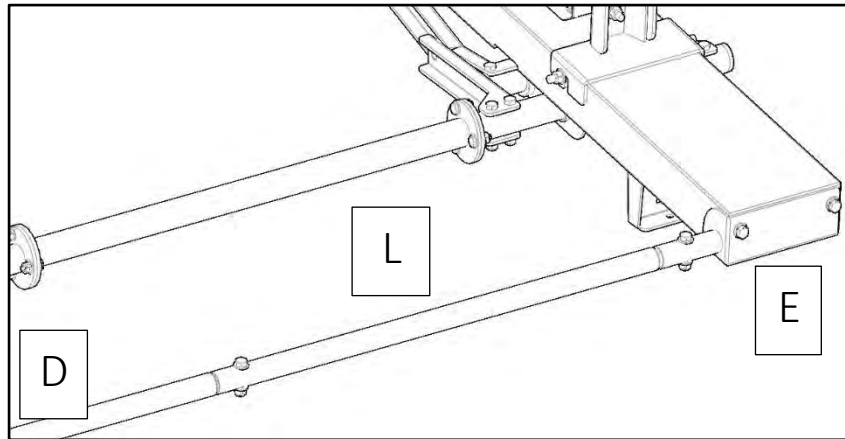

B.

- Attach Support Tube(D&E) to the Ladder pan as shown using .312" x .625 hex head (7) with .312" lock washers(8) and .312" flat washers(6)

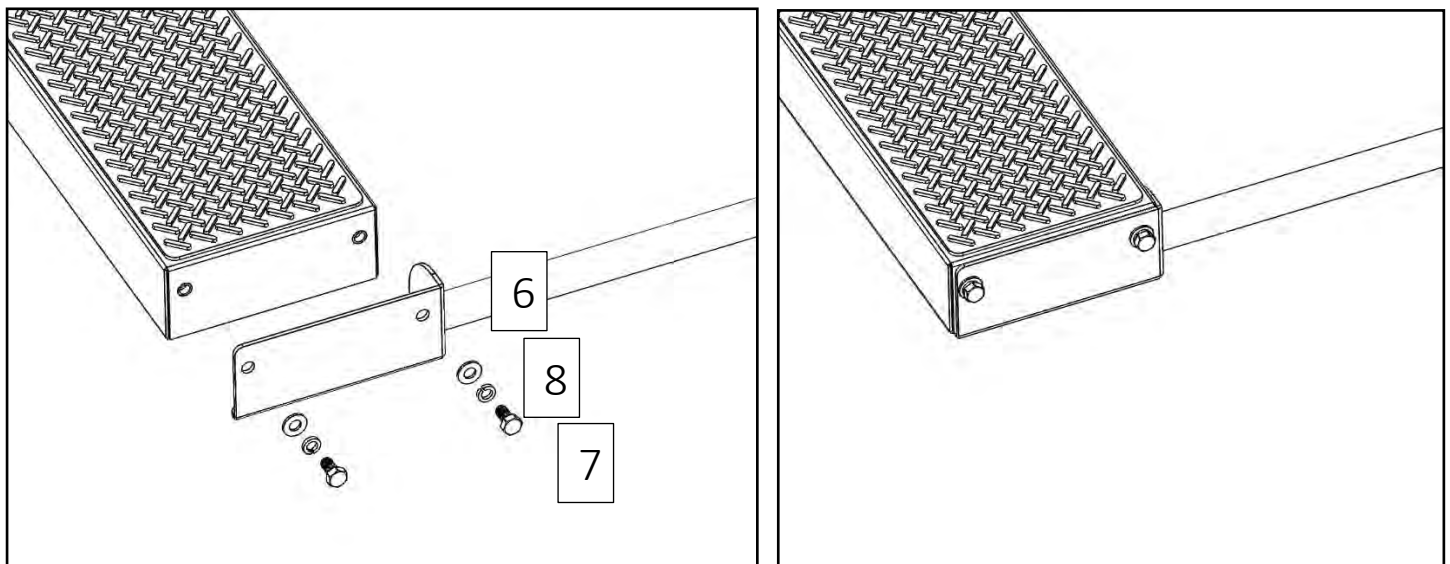

Step 5 – Ladder Stops and Hooks

- On the front bow (A), remove 3/8"x3/4" bolt, 3/8" split lock washer and 3/8" flat washer from shown location and install Ladder Stop(I).

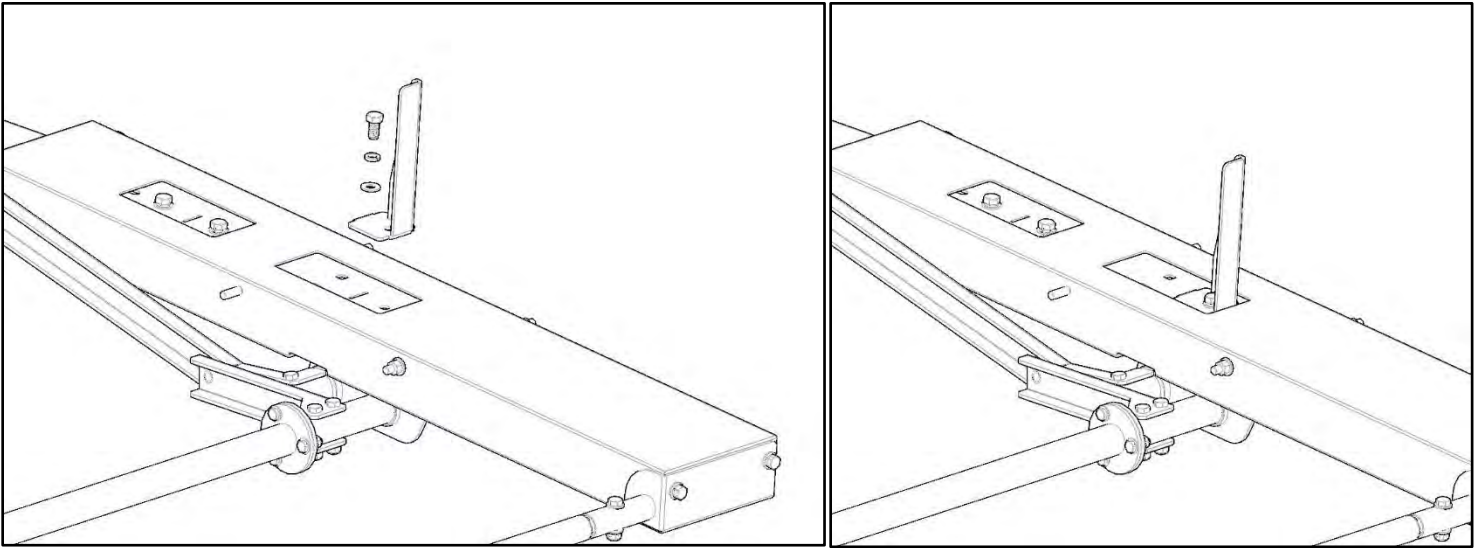

- Bolt Ladder Hook (H) to the lower position where the pem studs are installed. Use a .312 flat washer(6) and a .312 nyloc nut (9).

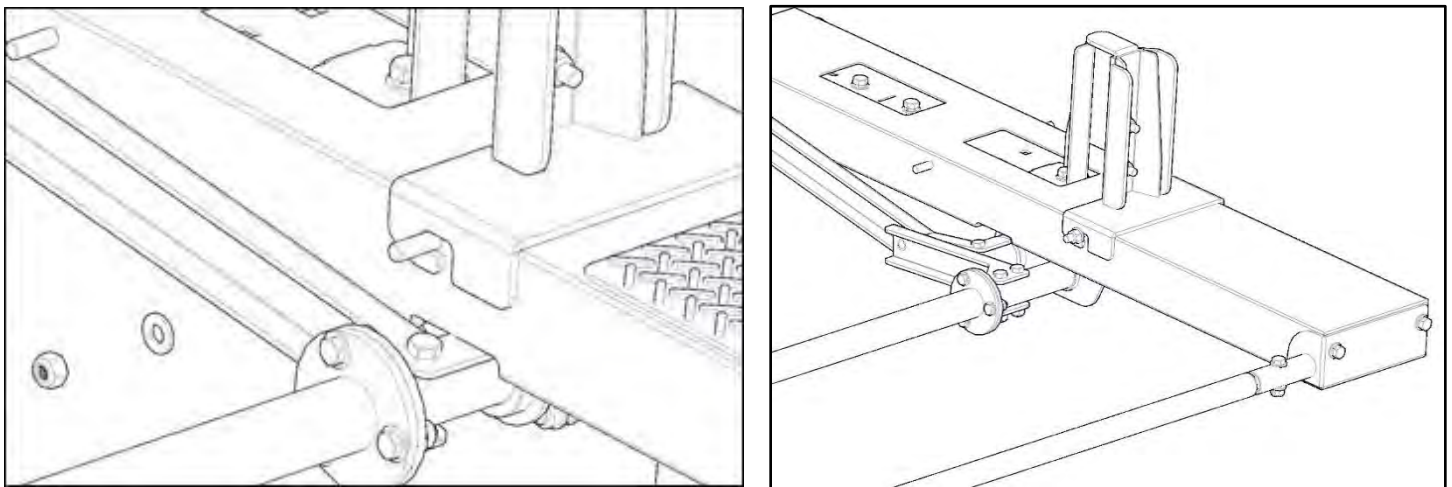

- Repeat on both sides of ladder hook (H).
- If using an "Extension Ladder" put the Ladder Stop(I) at the same location on the Front & Rear Bow Assy.(A&B).

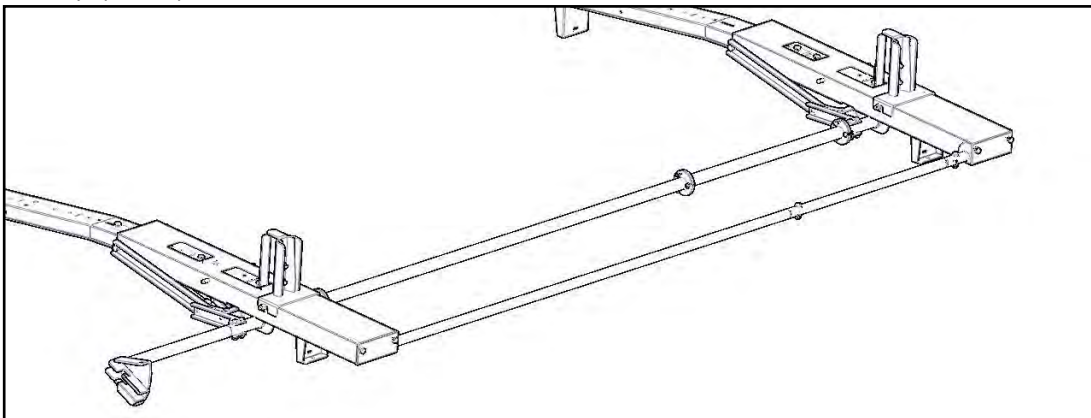

Step Ladder Set-Up

- If installing for a “Step ladder”, The ladder hook (H) and the ladder stop (I) change positions on the rear bow.
- Both of these parts move higher up on the bow and are installed using the other pem studs.

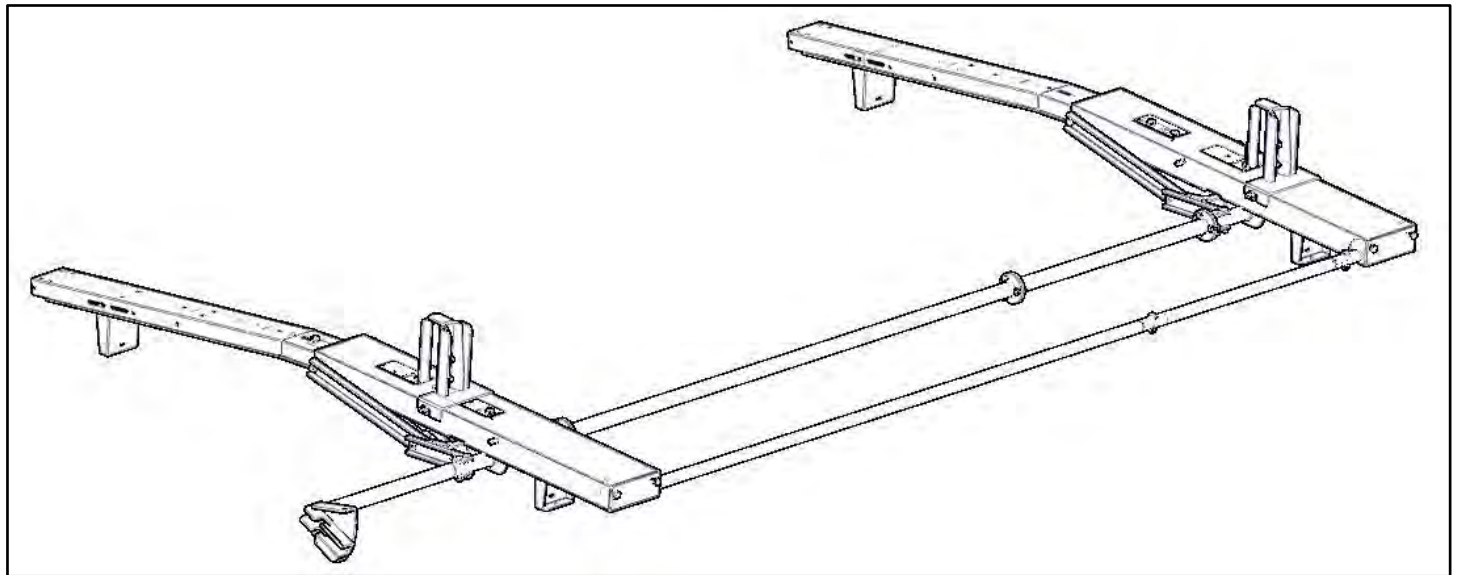
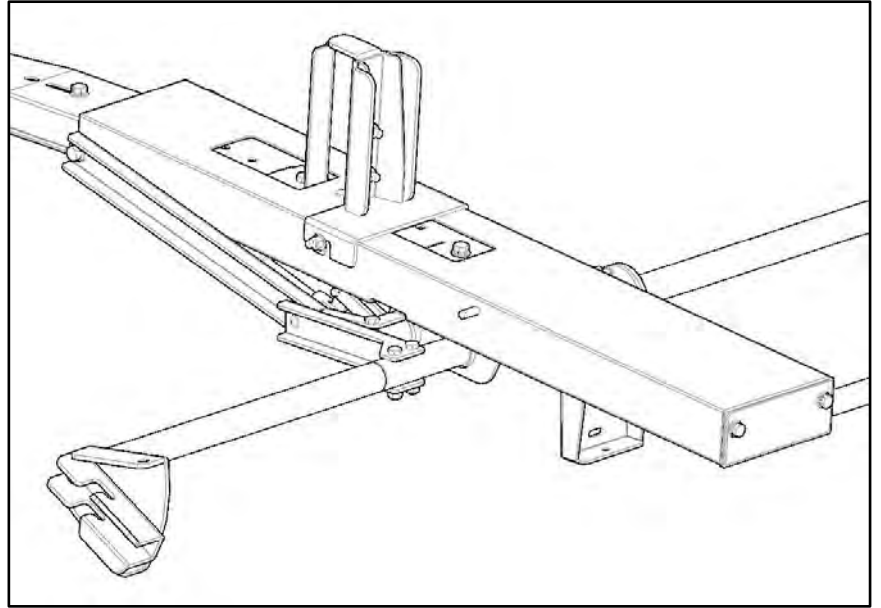

Step 6 – Installing Rack

- If you built the rack on the bench you can now set the rack on the mounts as described in Step 2.
- Be sure rack is centered on the van then TIGHTEN all the hardware.

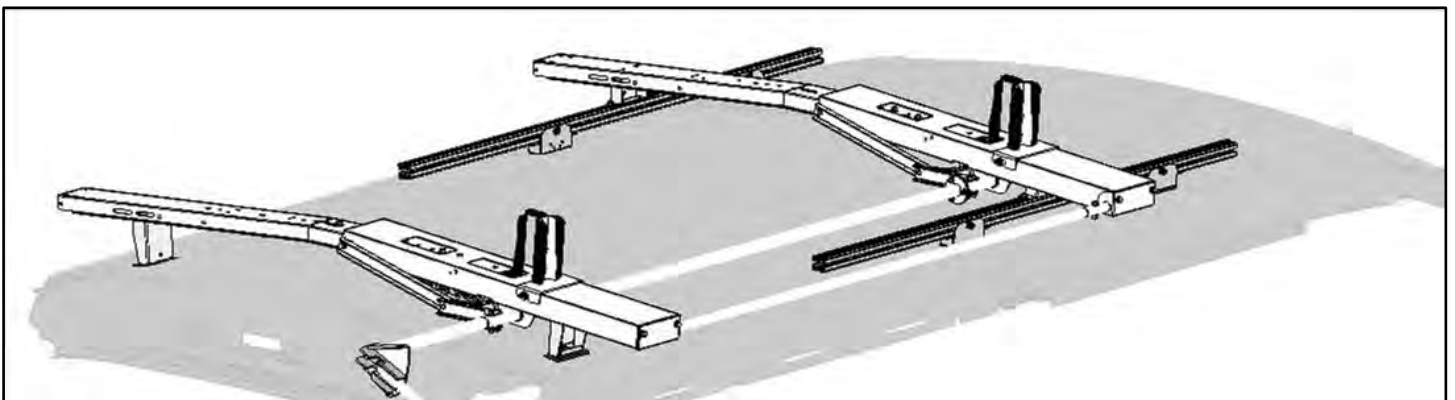



Step 7 – Install Handle Bar holder



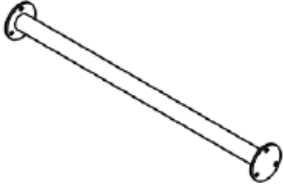
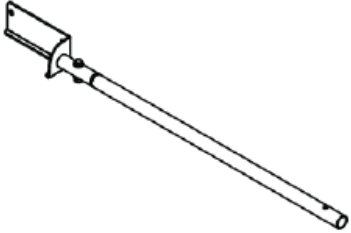
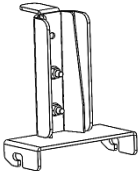

- Install handle bar holder clip from hardware kit to your preference. Most install at the rear of the van, on the backside of a shelving unit.
 - Install clips using #10 hardware provided.
-

GO BACK AND ENSURE ALL HARDWARE IS TIGHT

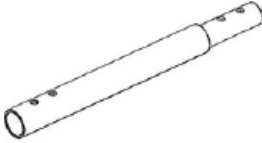
Your installation is now complete.

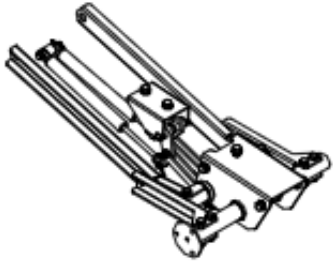
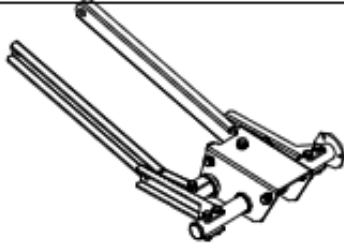
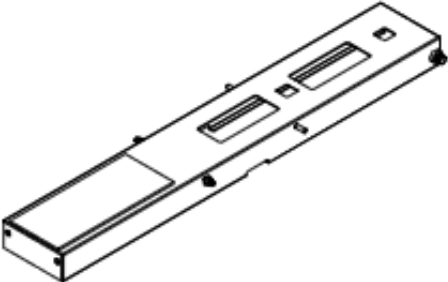
40913 Parts List

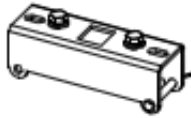
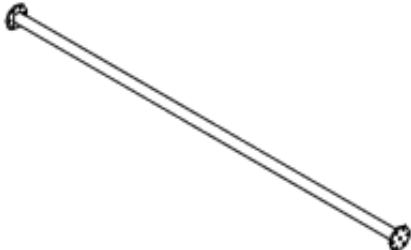
PART	PART NO.	QTY
	40993-25	1
	40993-831	1
	40900-31-R2	2
	40900-30-004	2
	spring	1
	40993-40-002	1

PART	PART NO.	QTY
	40993-08	1
	40993-09	1
	40993-10	2
	40993-45	1
	40993-12	1
	40993-24	1
	40993-832	1

40913 Hardware List

Tools Needed

8' Tape Measure
1/4" Socket
5/16" Socket

1/4" End Wrench
5/16" End Wrench
Hammer

Hardware Pack

(a)
Qty 2 -
Rubber Bumper



(b)
Qty 10 -
5/16" Flat Washer



(c)
Qty 4 -
5/16" Lock Washer



(d)
Qty 3 -
5/16"-18 Nyloc Nut

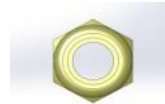

(e)
Qty 4 -
5/16"-18 x 5/8" Hex Bolt

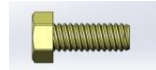

(j)
Qty 9 -
1/4"-20 x 7/8" Fully Threaded Hex Bolt



(k)
Qty 18 -
1/4" Flat Washer



(l)
Qty 9 -
1/4"-20 Nyloc Nut



(m)
Qty 1 -
E6000



(n)
Qty 4 -
3/8" Nylon Washer



(q)
Qty 1 -
5/16"-18 x 1.5" Hex Bolt



(r)
Qty 2 -
5/16"-18 x 1.75" Hex Bolt

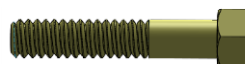

Step 1

Bolt "Dampener mounting bracket(40993-12)" underneath the crossbow (only the front side of the vehicle) as shown below using 3/8"x3/4 Bolts with flat and lock washers.

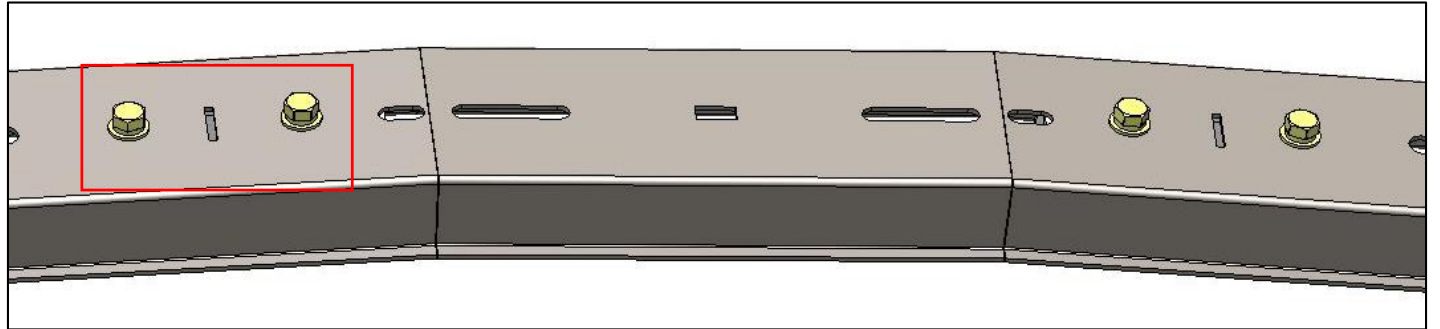
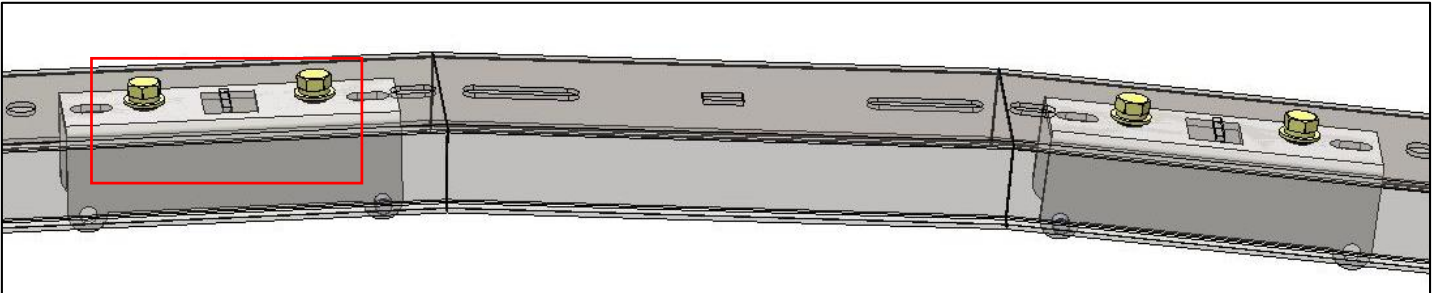
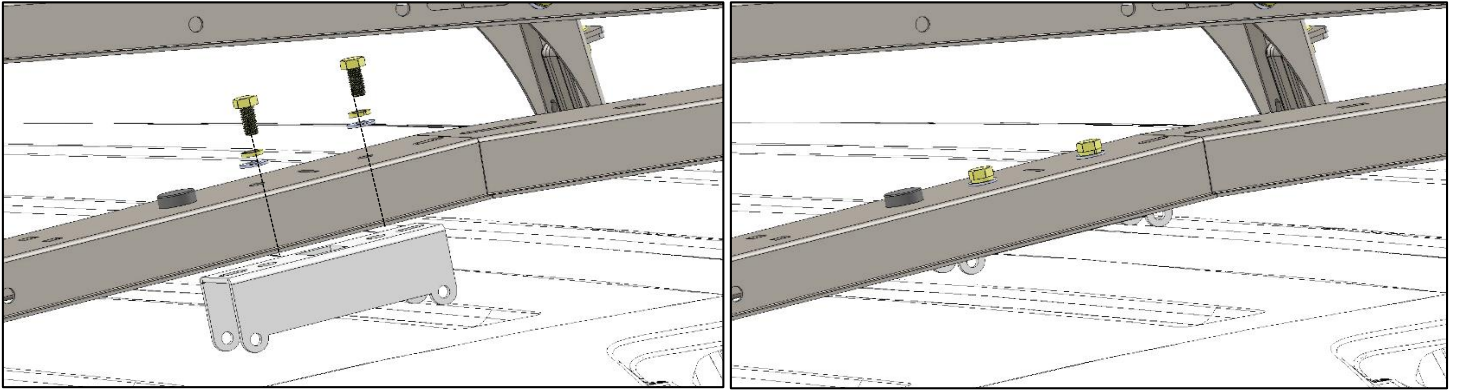

Step 2

Bolt "Torque tube pivot Assy. (40993-09)" underneath the front crossbow (Front side of vehicle) as shown below using 4 of 3/8"x3/4 Bolts with flat and lock washers. Repeat this step on the other side of the bow. You may need to un-bolt the mounting front from the crossbow to do this.

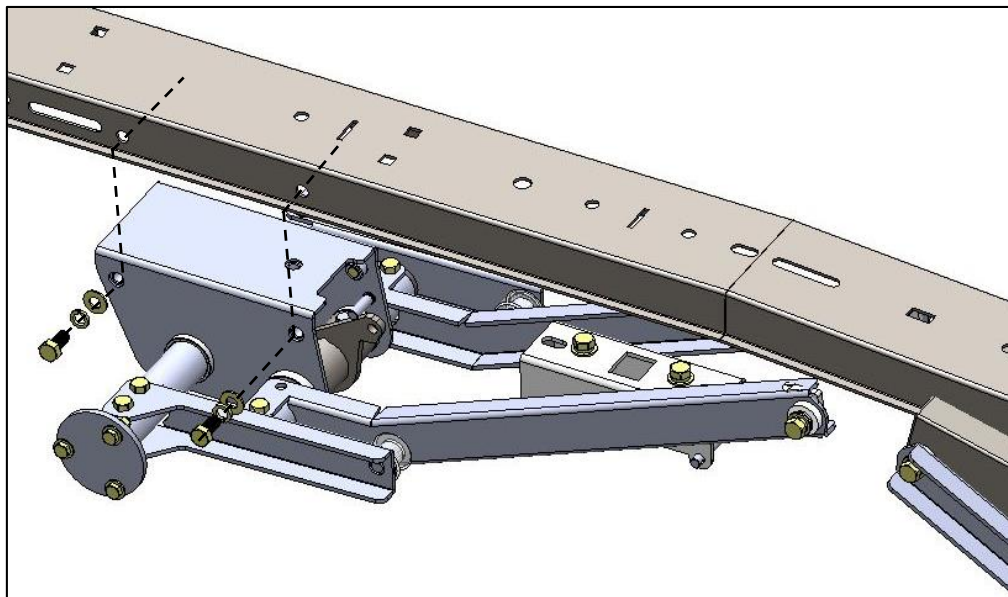

Step 3

Bolt "Torque tube pivot Assy. 2(40993-8)" underneath the rearcrossbow (rear side of the vehicle) as shown below using 3/8"x3/4 Bolts with flat and lock washers. You may need to un-bolt the mounting front from the crossbow to do this.

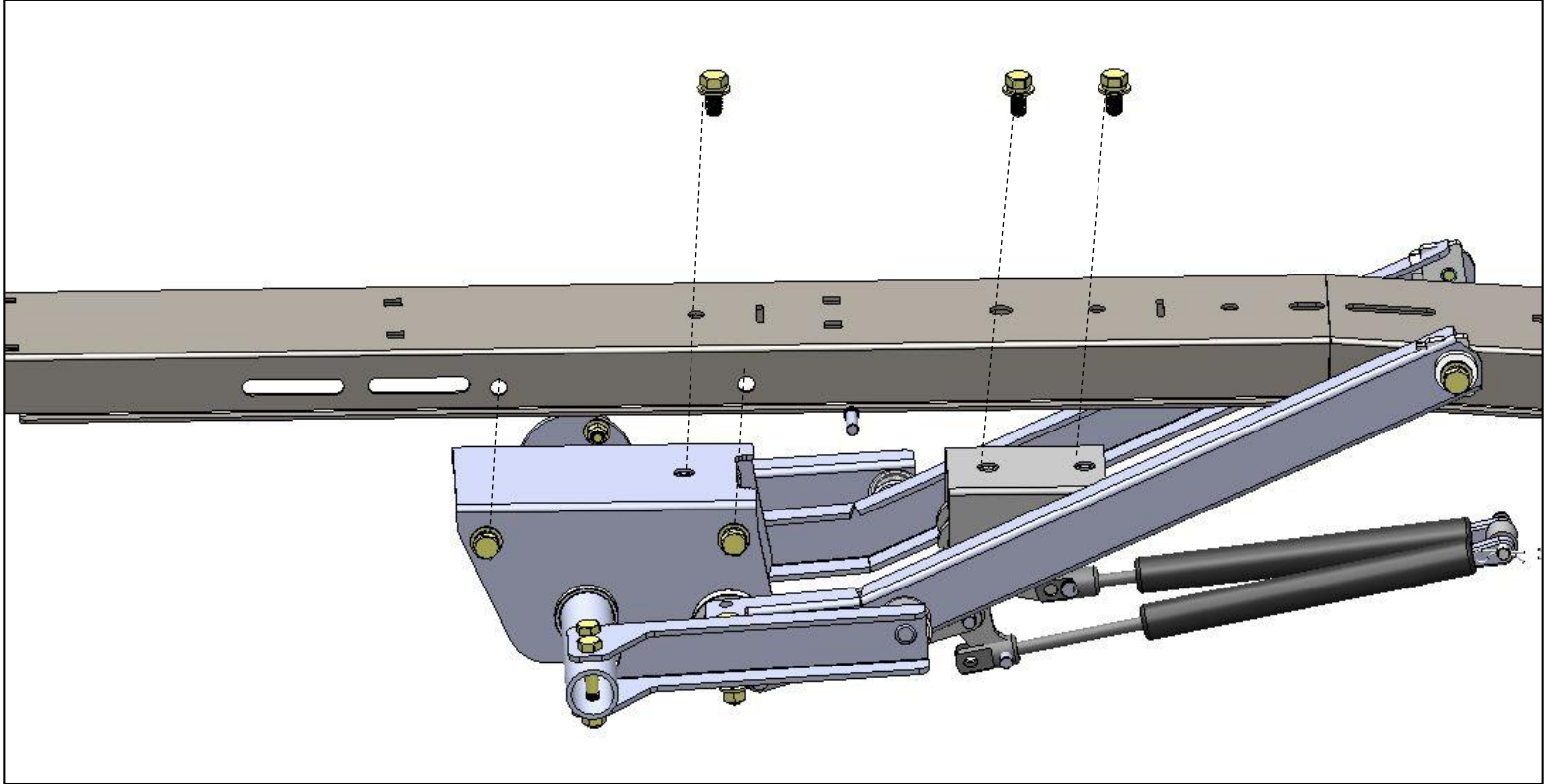

Step 4

Attach the open end dampeners to the center bracket using the 5/16"x2- 1/4" pin, sandwich the nylon spacer to secure the dampener in the middle of the bracket.

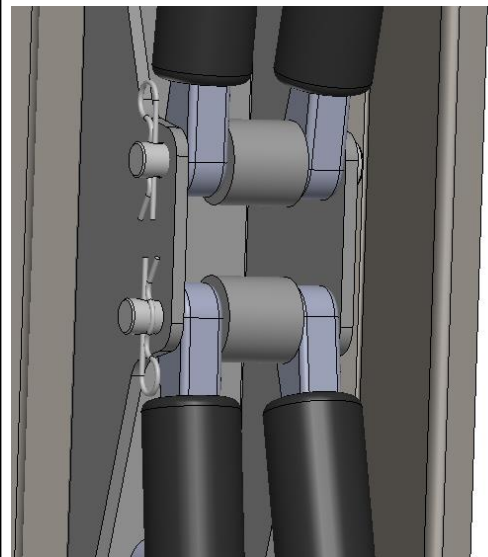
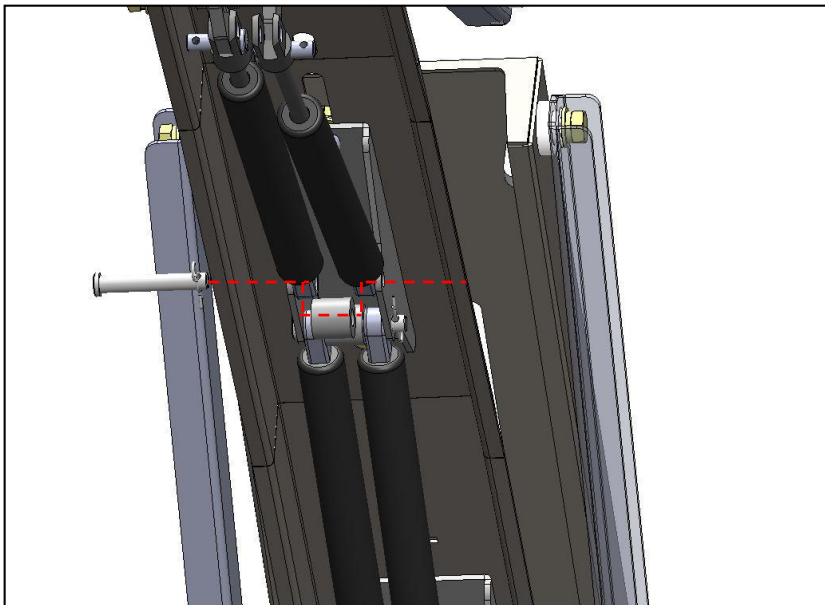

Step 5

Attach torque tube(40993-25 and 40993-24) using ¼" bolts (J) with flat washers(k) and nyloc nuts(l). Check distance between feet on both driver and passenger side, they must be EXACTLY the same to insure the bow assemblies are parallel.

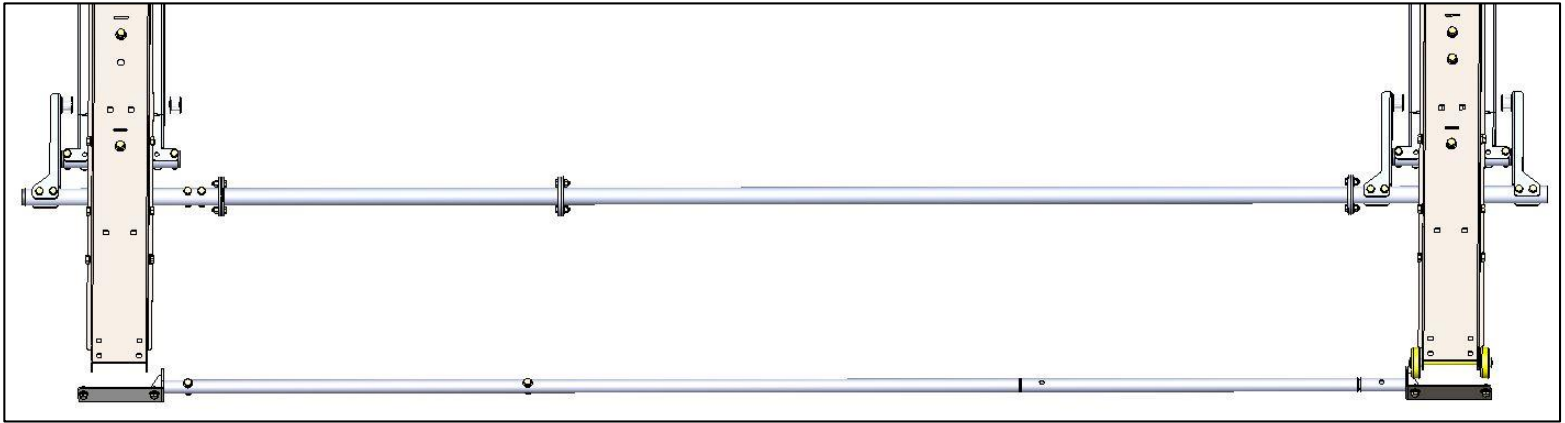
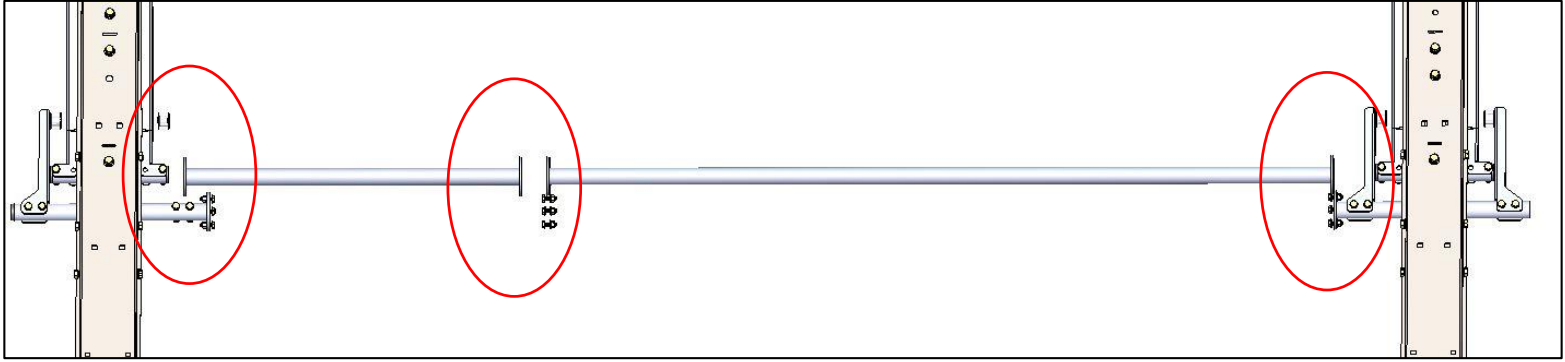

Step 6

Next install the "Axles" and "Rollers" at the end of both front and rear crossbow. The "Axle" just slides in and the "Rollers" slide over the ends of the "Axle" as shown below, make sure insert the nylon washers(n) between the wheels and crossbow.

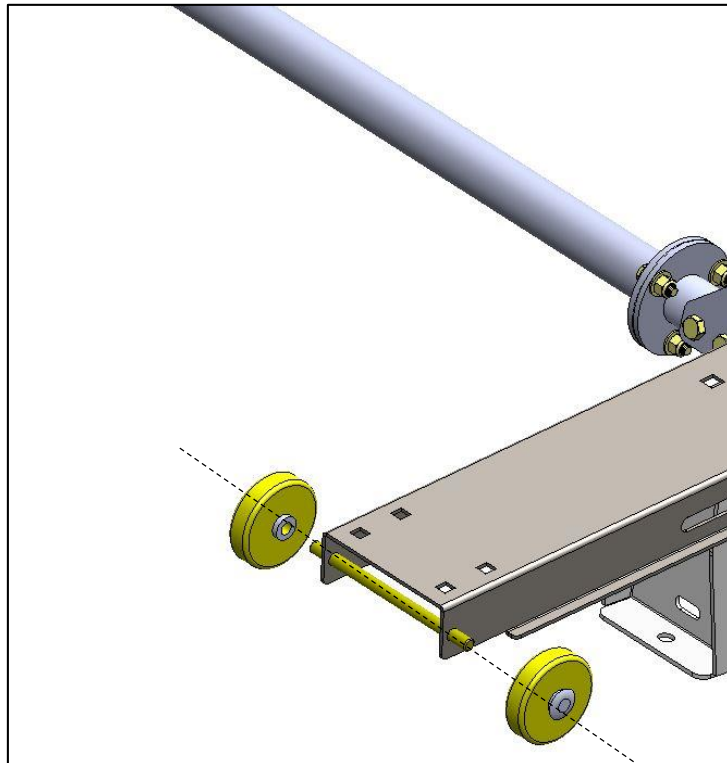

Step 7

Next install the "Ladder Pan Assy." Align cutouts in "Ladder Pan Assy.(40993-10)" with the "Rollers" and guide the arms onto the "Torque Tube Pivot Assy." As you lower the Pan assembly onto the rollers, remove the bolt assembly pre-installed on Ladder Pan, and use the same bolt assembly to secure the Arm with Ladder Pan. **Caution: Make sure the nylon spacer is sandwiched between the Arm and Ladder Pan, and lock washer or nyloc nut is used on this assembly.**

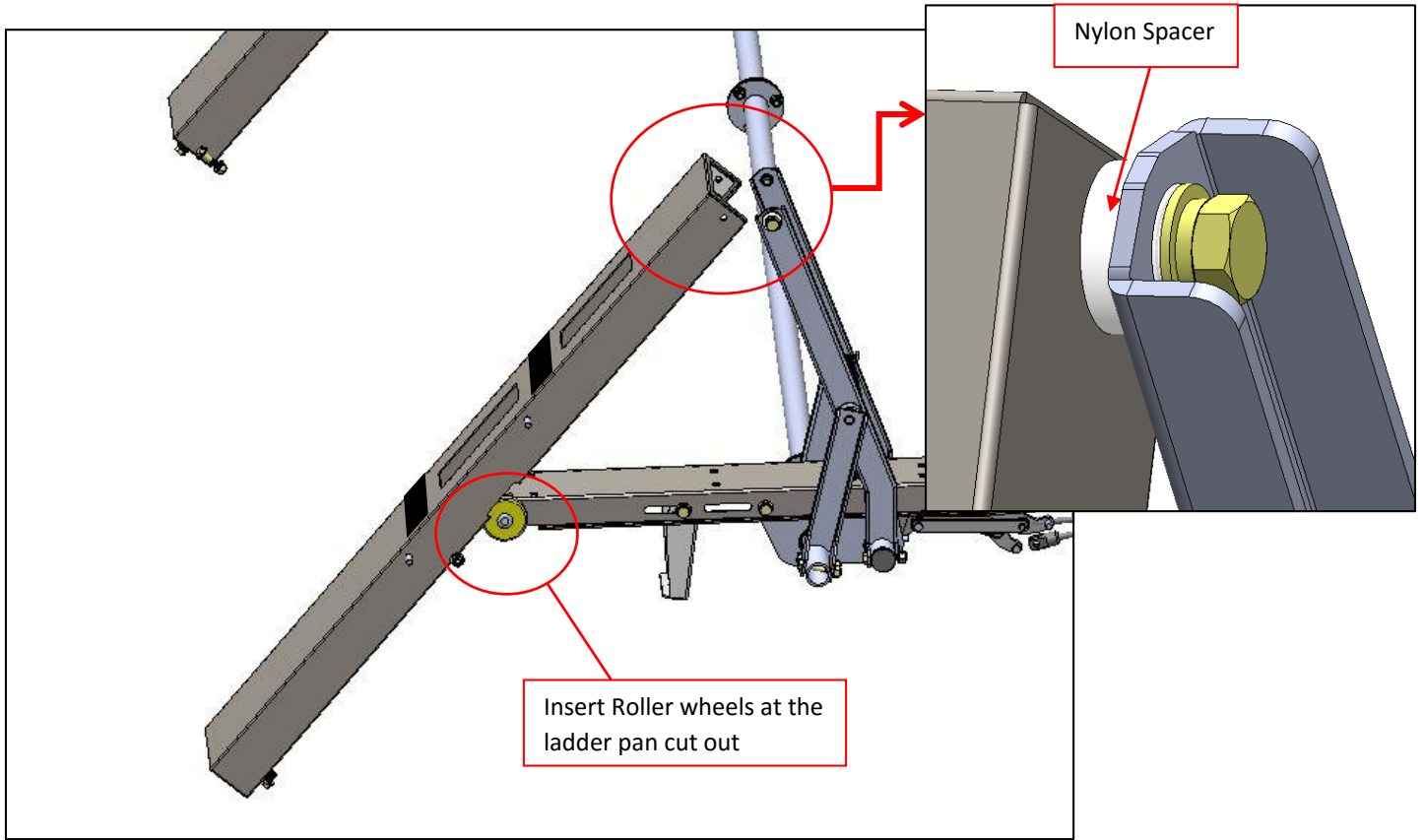

Step 8

Next attach the "Handle Assy. (40993-45)." as shown. **Optional:** If Handle Assy. does not extend far enough to clear rear vehicle, add the Extension Tube (40993-40-002) using 2 of 5/16" x 1.75" bolt (r), flat washer (b) and Nyloc Nut (d) to extend the Handle Assembly.

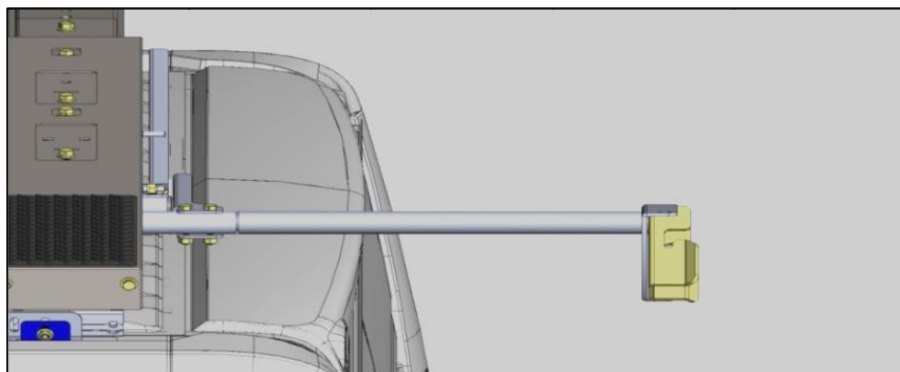
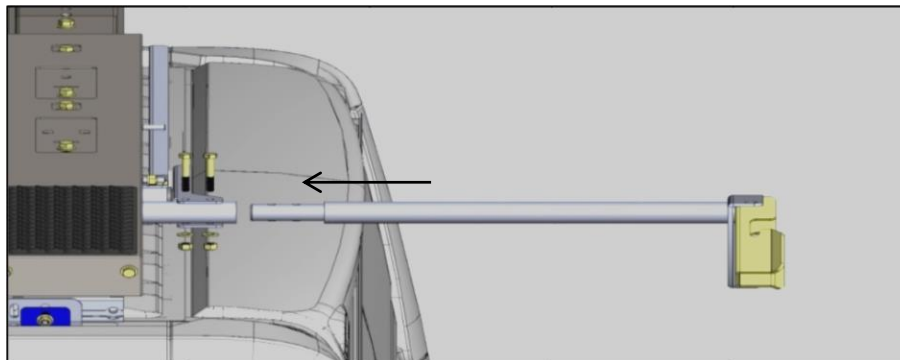

Step 9

Next attach the "Ladder Hooks (40800-31)" and "Ladder Stops (40900-30-004)". Attach "Ladder Hooks" to ladder pans on 5/16" studs in desired location. Attach "Ladder Stops" to coincide with "Ladder Hooks" by removing 3/8"x3/4" bolt and placing stop so the tab on the stop goes into the corresponding slot. If using a "step ladder" mount "Ladder Hooks" in the upper location in the rear. If you are using an "extension ladder" use the same location as the front bow.

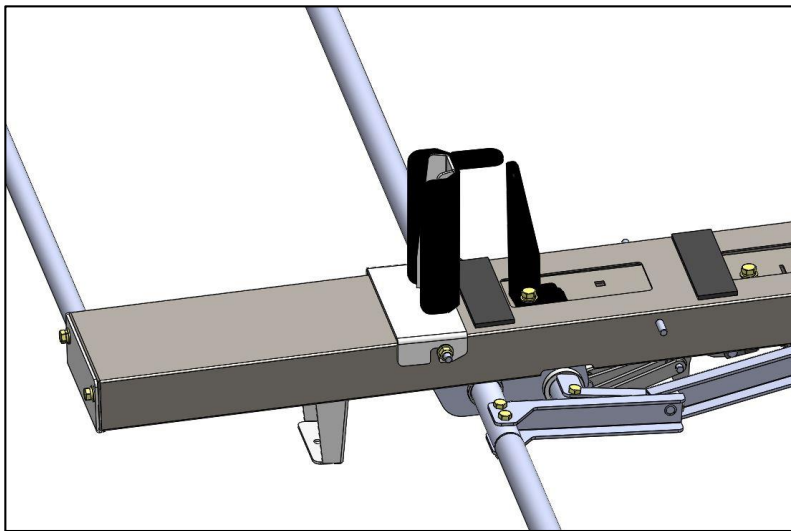
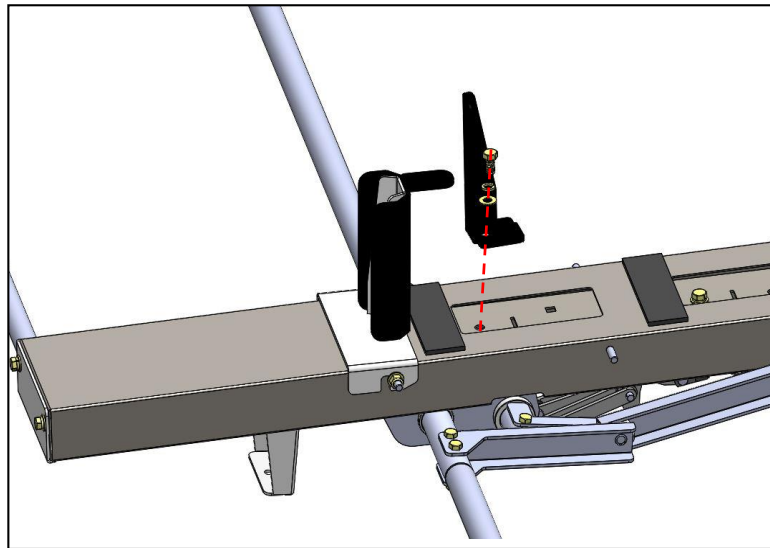
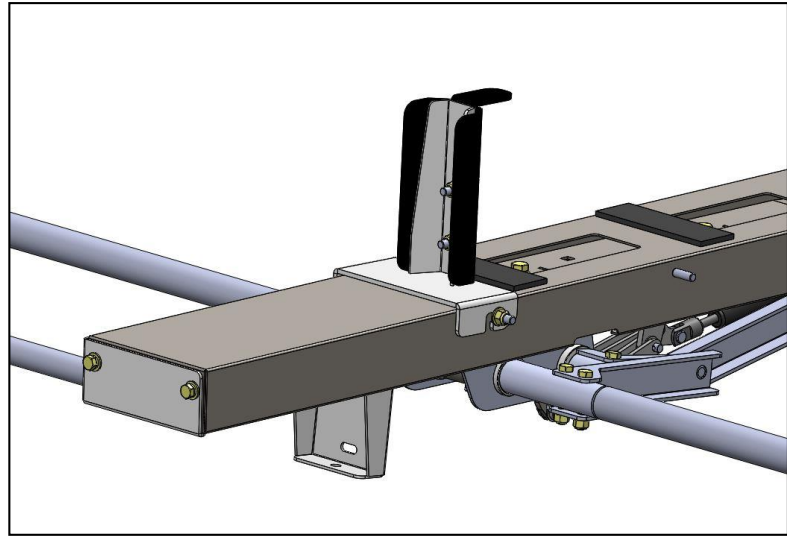
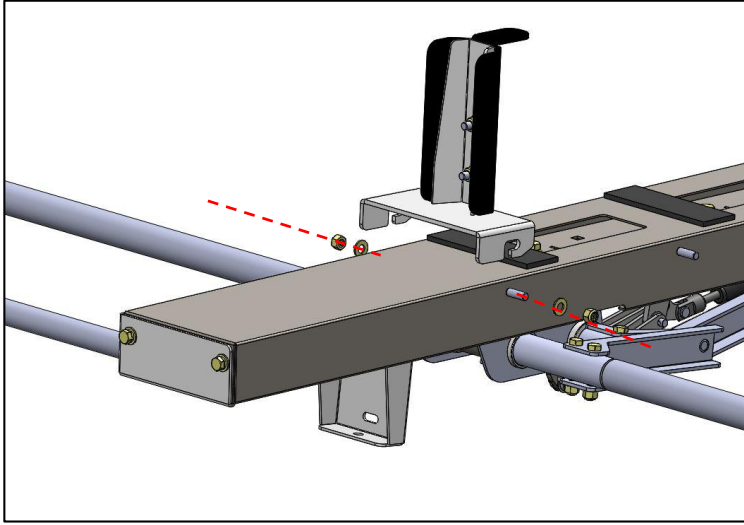

Step 10

First using 5/16"x1.5" Hex bolt (q) with two flat washers(b) and nyloc nut (d) to connect the ladder pan stiffener (40993-31 and 40993-832) and USE E6000(m) AROUND HOLES. Attach ladder pan stiffener, in the closed position, using 5/16"x5/8" bolts (e) with lock washers (c) and flat washers (b). Confirm that distance between passenger side feet and driver side feet are still EXACTLY the same. Now you can tighten the feet for the front and rear bow assemblies.

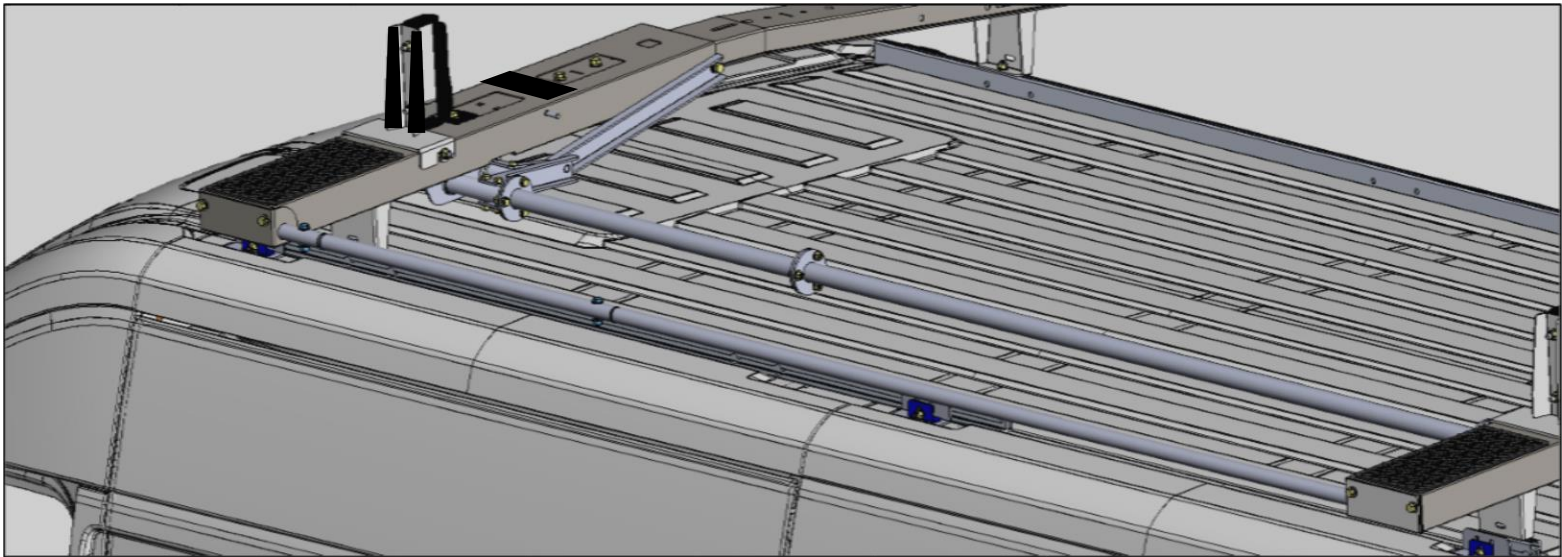
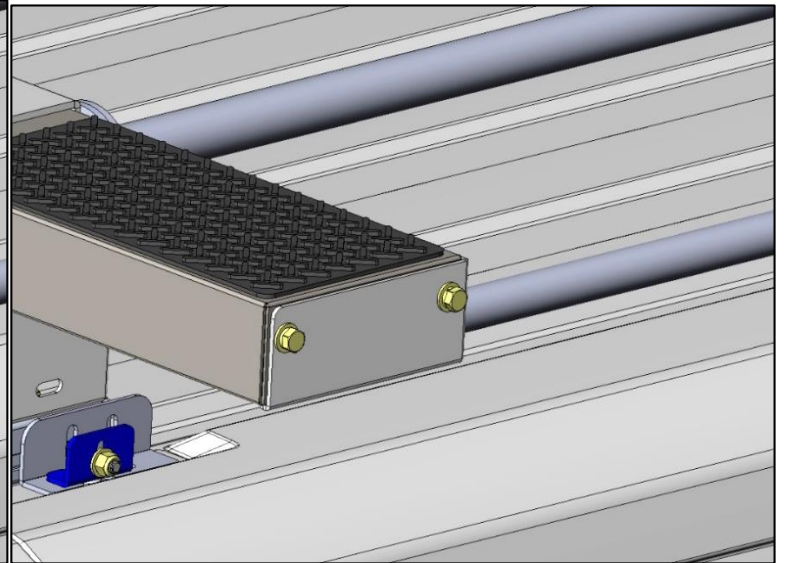
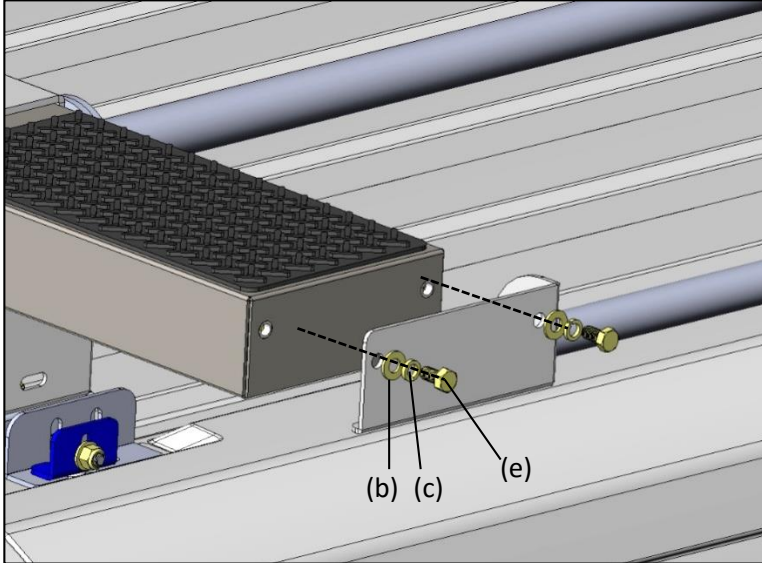

Step 11

Place the rubber bumper(a) to both front and rear crossbow as shown below.

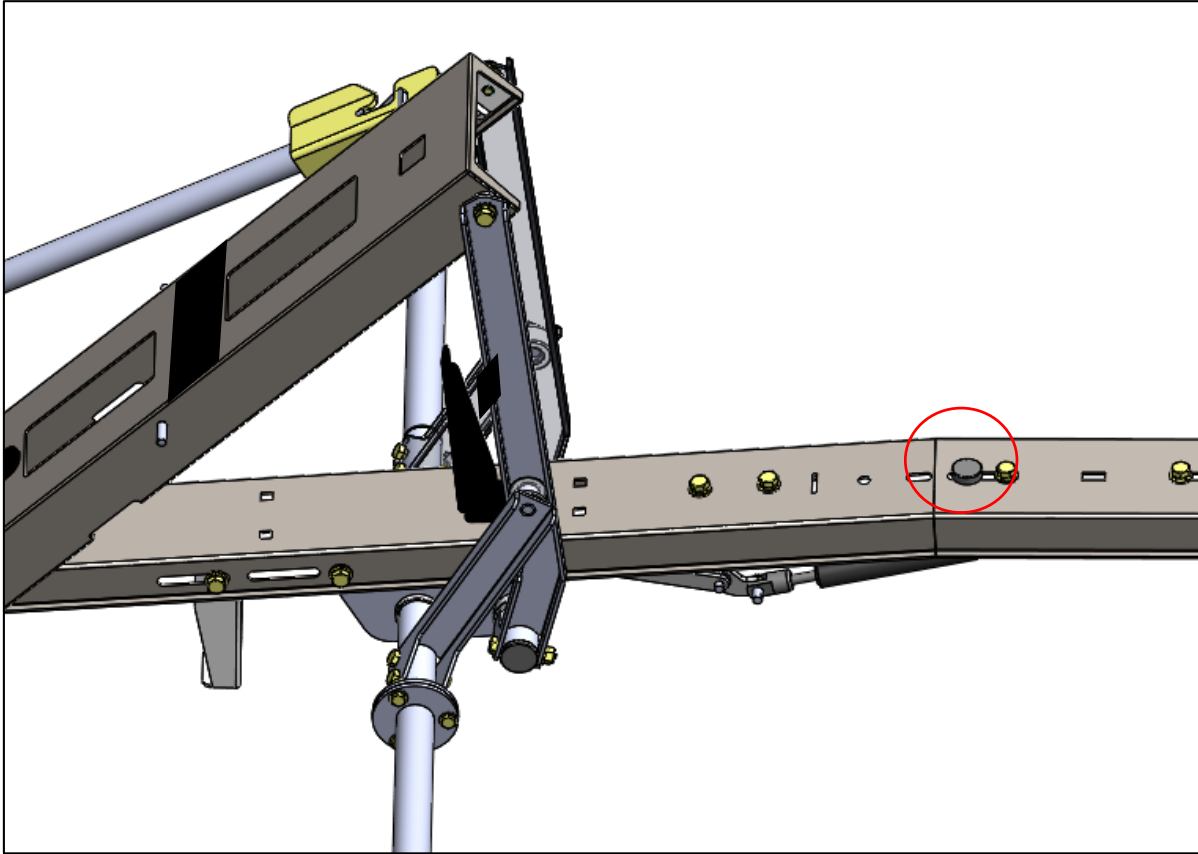

Installation is now complete.

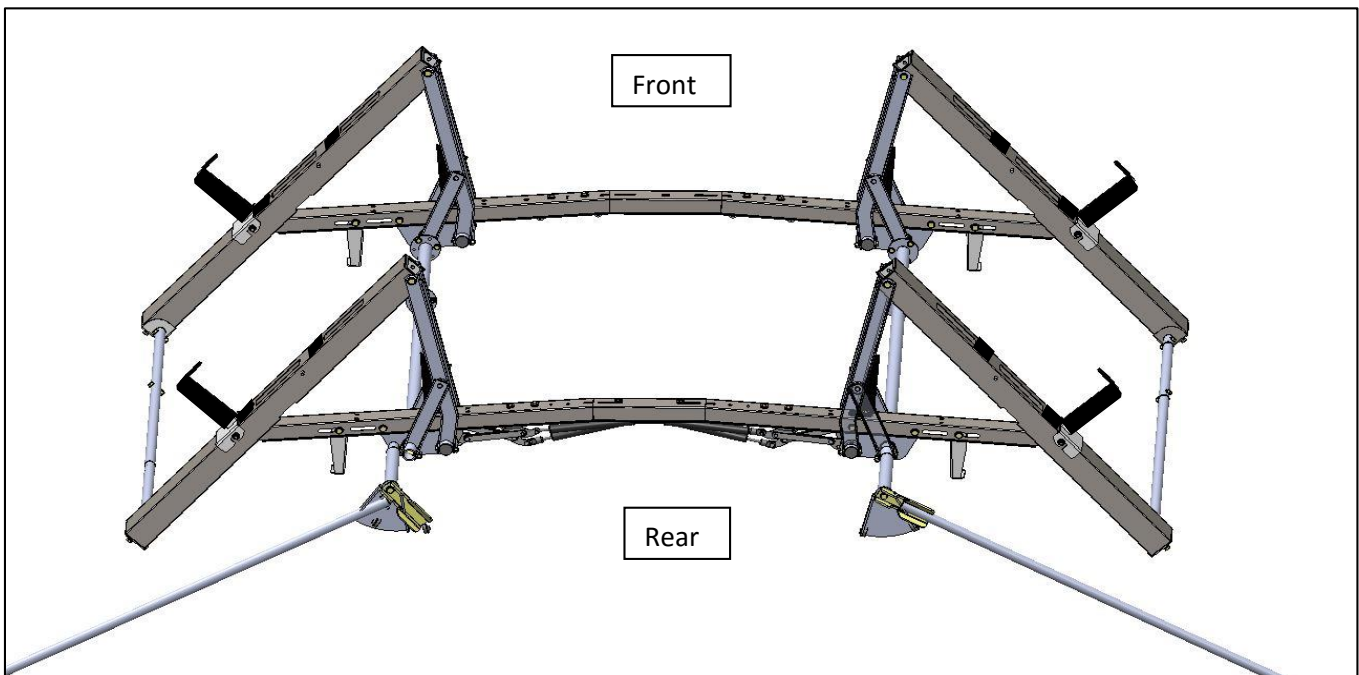

Discover other commercial van equipment on our website.