

KARGO MASTER

40933 Parts List

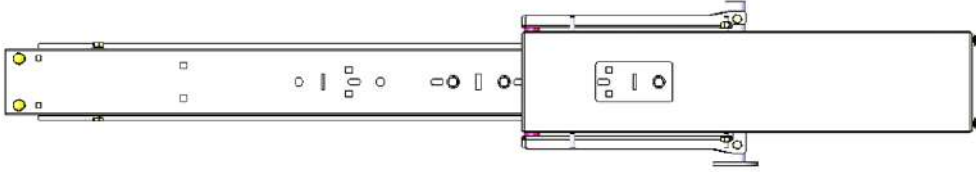

Front Bow Assy. (1)

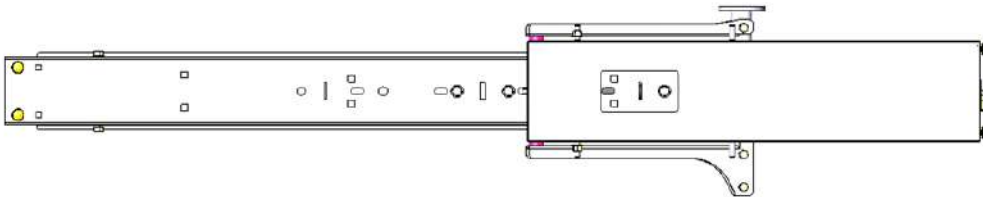

Rear Bow Assy. (1)



Rail Mount Foot (4)



Latch (1)



Ladder Hook (2)



Ladder Stop (2)



Torque Tube (1)



Ladder Pan Stiffener (1)



Mount Rail (2)



Handle Assy. (1)

40933 Hardware List

Tools Needed

8' Tape Measure	1/2" End Wrench
1/2" Socket	9/16" End Wrench
9/16" Socket	Hammer
7/16 Socket	

Hardware Pack

(a)
Qty 6 -
5/16"-18 x 3/4" Carriage Bolt



(b)
Qty 26 -
5/16" Flat Washer



(c)
Qty 8 -
5/16" Lock Washer



(d)
Qty 14 -
5/16"-18 Nyloc Nut



(e)
Qty 4 -
5/16"-18 x 5/8" Hex Bolt

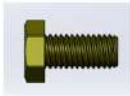

(f)
Qty 6 -
Round Rubber pad



(g)
Qty 4 -
Fender Washer - 24mm OD x 2mm TK



(h)
Qty 4 -
M8 Nyloc nut



(i)
Qty 4 -
5/16"-18 x 1" Hex Bolt



(j)
Qty 8 -
3/8"-16 x 3/4" Hex Bolt



Hardware Pack Cont'

(k)
Qty 8 -
3/8" Flat Washer



(l)
Qty 8 -
3/8" Lock Washer



(m)
Qty 6 -
1/4"-20 x 7/8" Fully Threaded Hex Bolt



(n)
Qty 12 -
1/4" Washer



(o)
Qty 6 -
1/4"-20 Nyloc Nut



(p)
Qty 4 -
M8 x 25mm Hex Bolt



(q)
Qty 2 -
M8 x 20mm Counter Sink Bolt



(r)
Qty 1 -
Joint Sealant



(s)
Qty 6 -
M6 x 20mm Hex Bolt

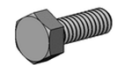

(t)
Qty 6 -
M6 Flat Washer



(u)
Qty 6 -
M6 Lock Washer



Step 1 For Ram Promaster City

Install "Mount Rail" as shown using M6x20mm bolts (s) with lock washers(u) and flat washers(t). Be sure to put rubber washer(f) between the "Mounting Rail" and the roof to insure sealing. (Passenger side shown)

FRONT

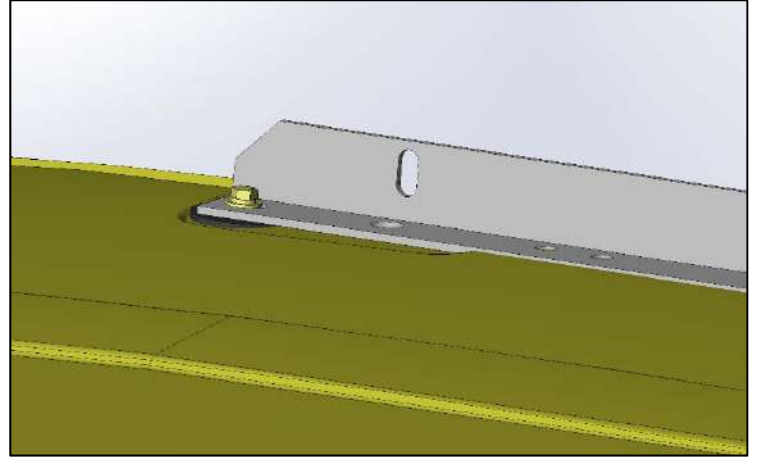
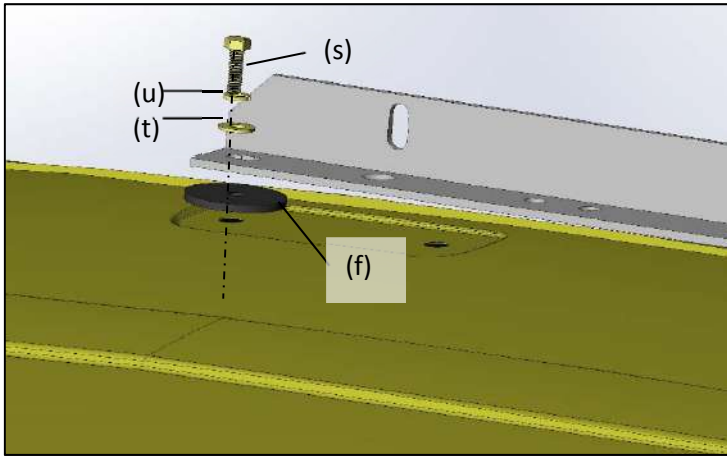

BACK

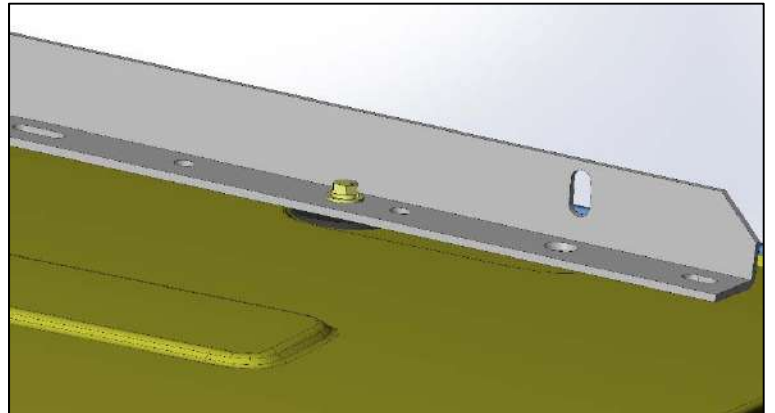
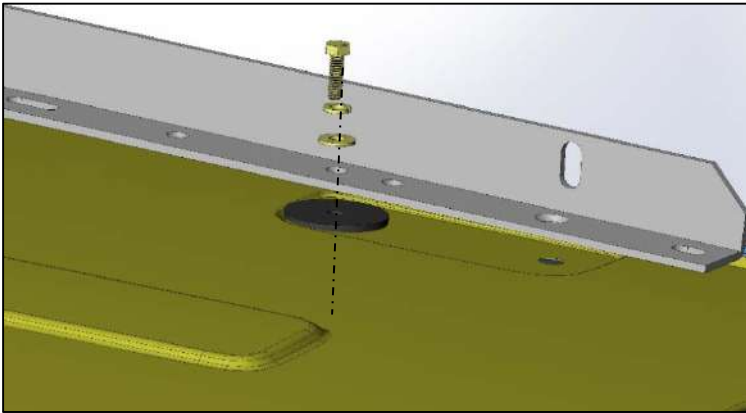

Middle

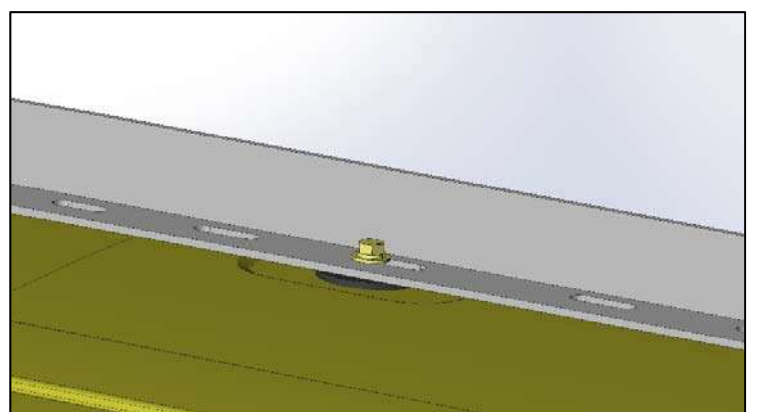
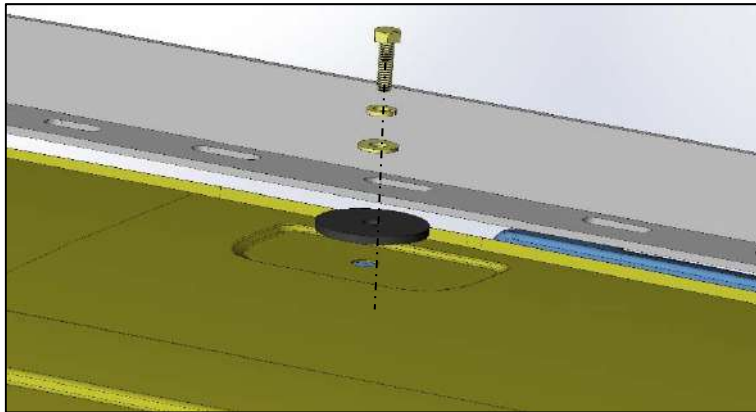

Step 1 For NV200/Chevy City Express/2014 Transit Connect

Mount rail to roof using M8x25 Bolts (p) with flat washer (b) and lock washers(c) (on 2014 and newer Transit Connect use nyloc nut with fender washer and rubber washer on the underside-Do not use lock washer). Mount rail so that the end of the rail is approximately 1" (usually the 2nd or 3rd hole-Use countersunk hole for 2013 and older Transit Connect) from where the rear door opening is.

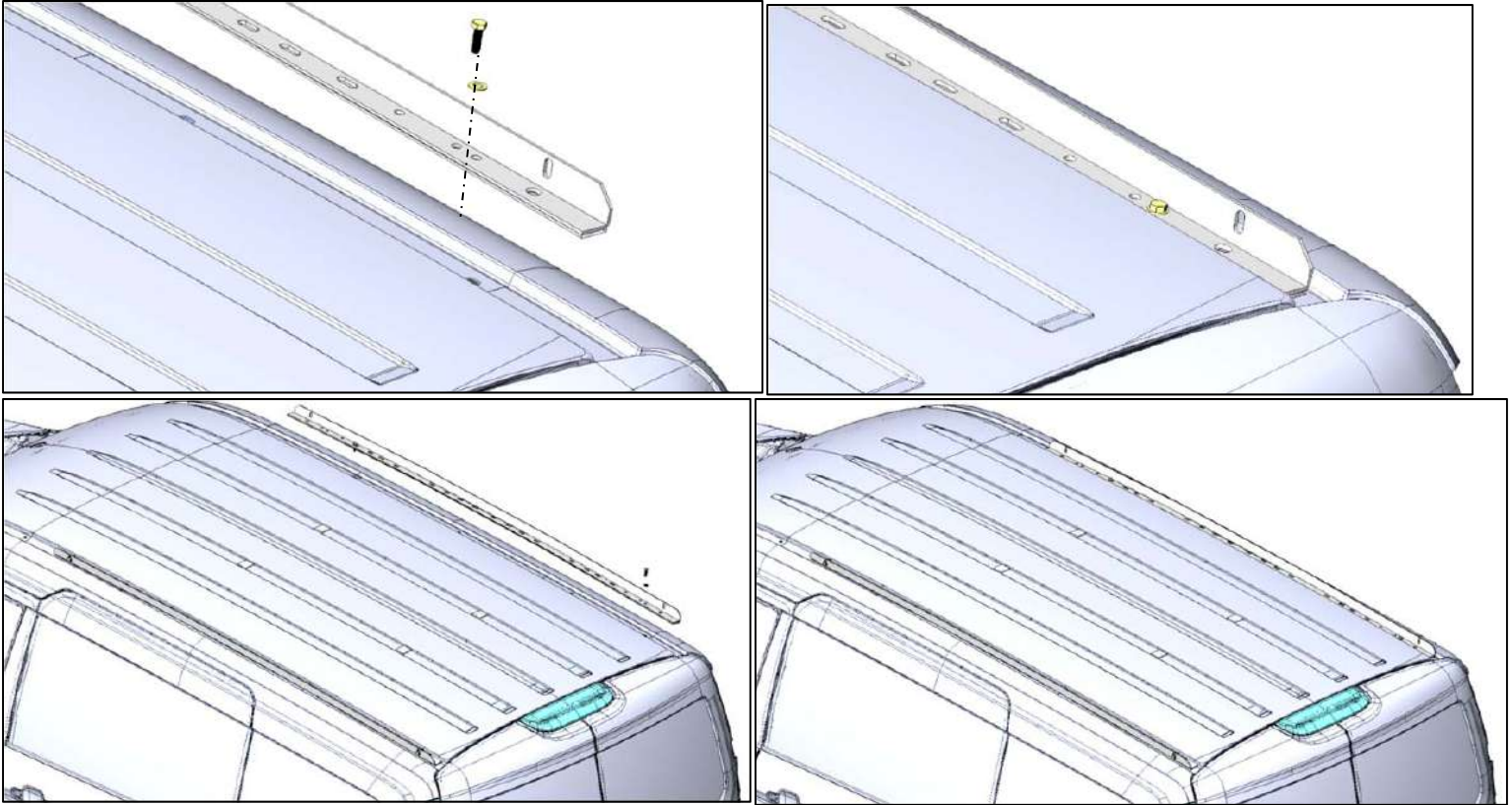

Step 2

Measure width the rail and bolt feet to bows at that approximate location as shown, DO NOT TIGHTEN at this point.

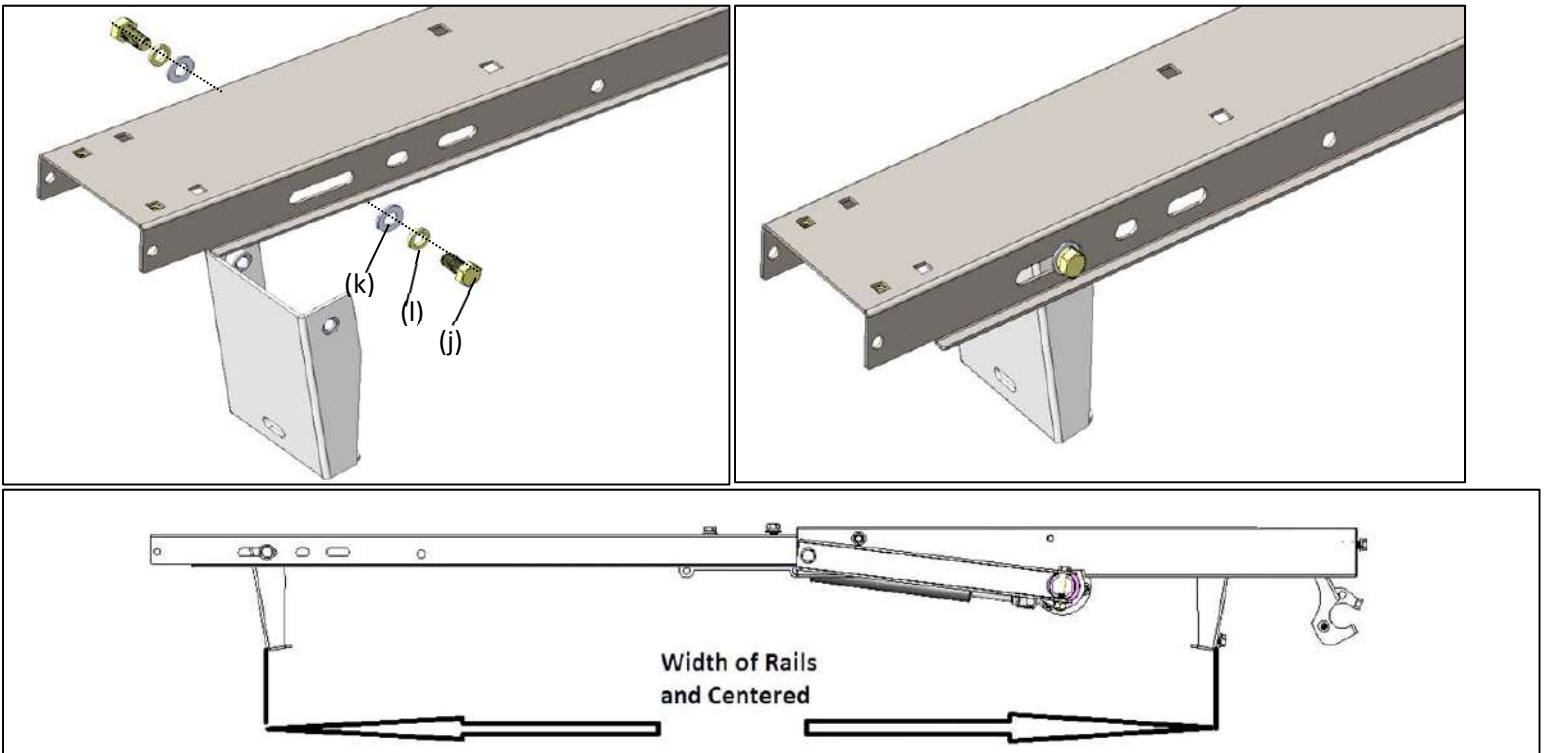

Step 3

Bolt "Latch" as shown using 5/16"x3/4" carriage bolts (a) with flat washers (b) and nyloc nuts (d).

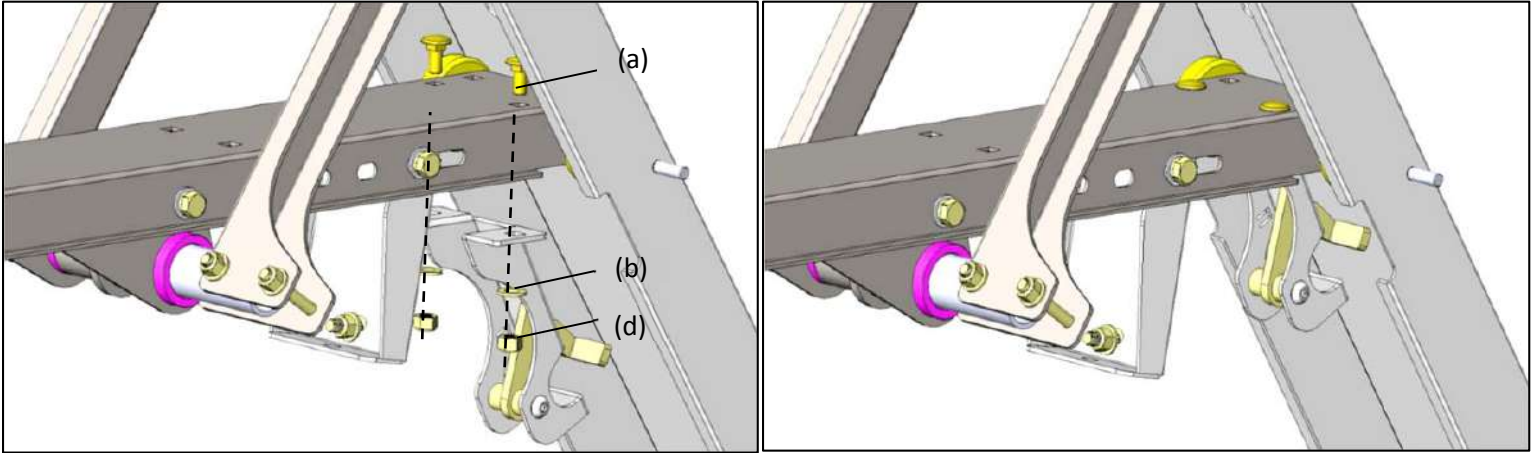

Step 4

Next bolt the Angle bracket on the driver side of the bows using 5/16"x3/4" carriage bolts with nyloc nuts and flat washer as shown.

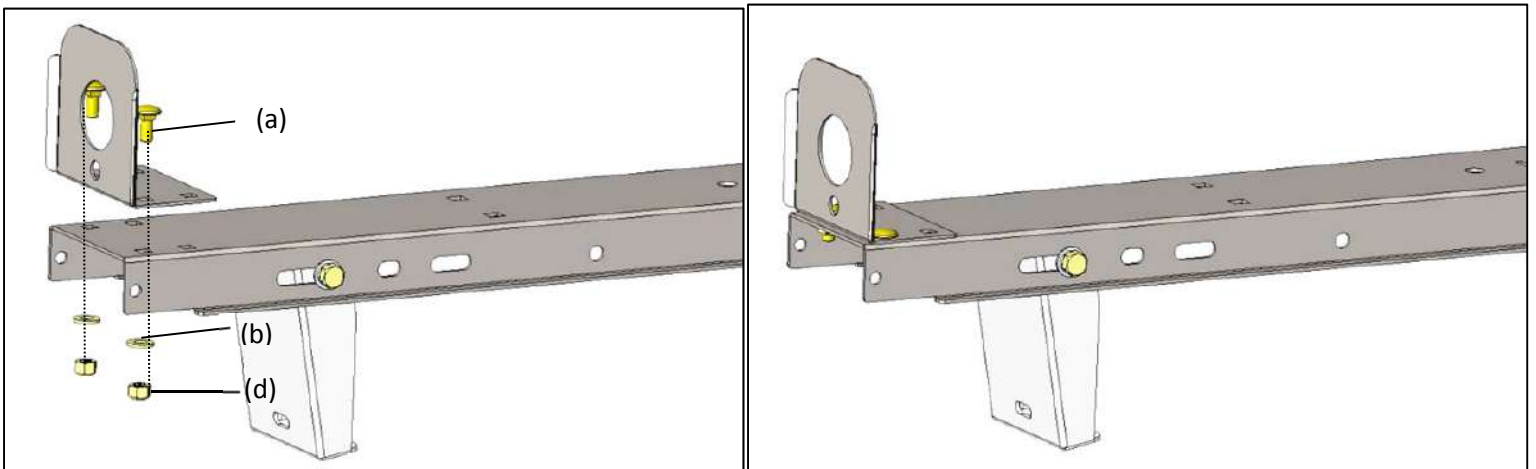

Step 5

Place "Rear Bow Assy." as shown and bolt to rails using 5/16"x1" bolts (j) with nyloc nuts(d) and flat washers(b), DO NOT TIGHTEN at this time.

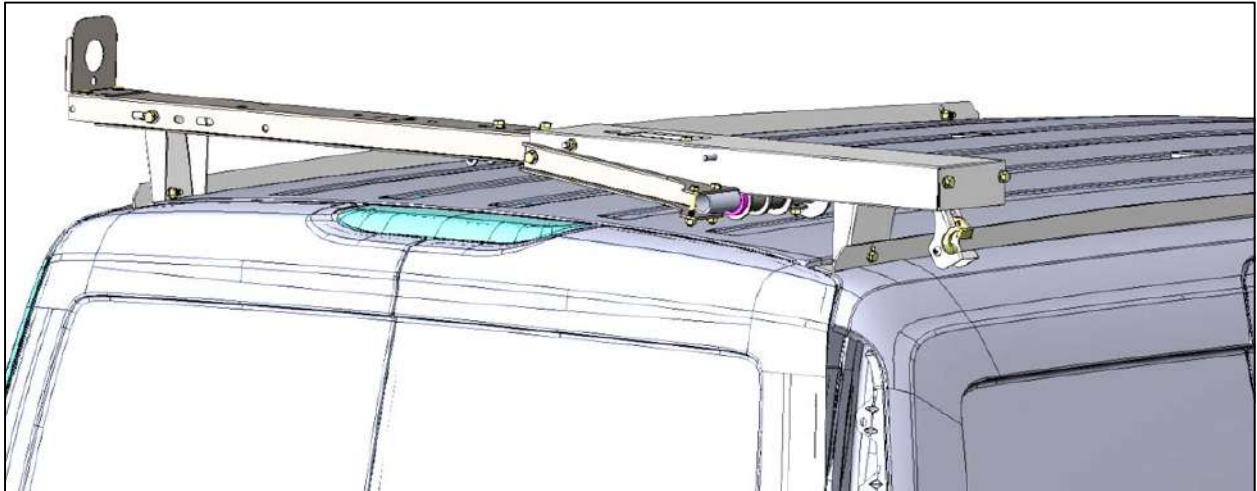
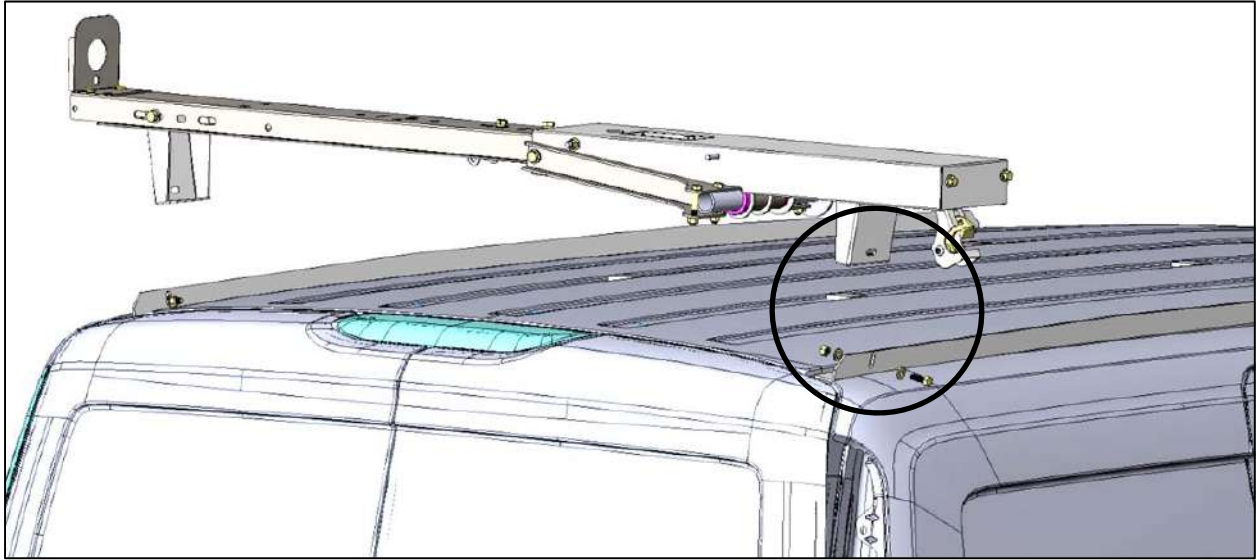

Step 6

Place "Front Bow Assy." as shown and bolt to rails using 5/16"x1" bolts(i) with nyloc nuts(d) and flat washers(b), DO NOT TIGHTEN at this time.

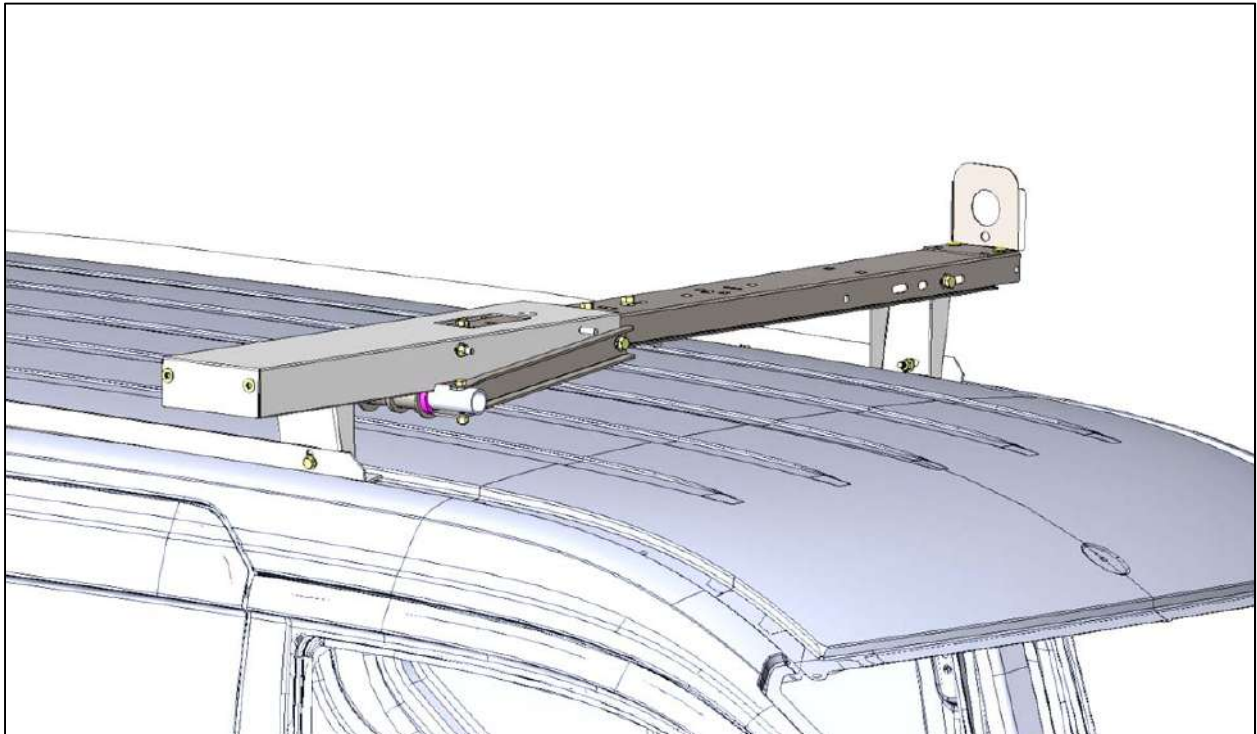
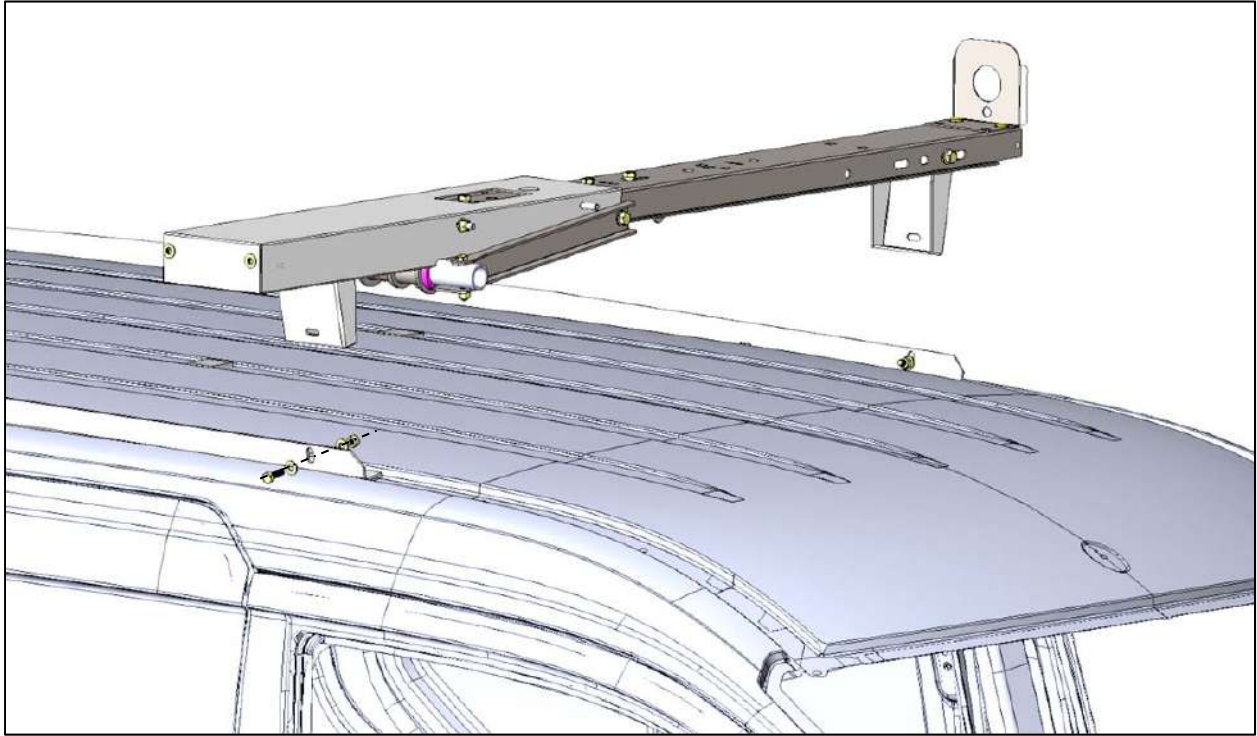

Step 7

Bolt the "Torque Tube" using $\frac{1}{4}$ " x $\frac{7}{8}$ " bolts(m) with flat washer(n)s and nylock nuts(o). This sets the distance between the front and rear assembly (71.5" center to center), be sure both sides measure the same to ensure proper operation.

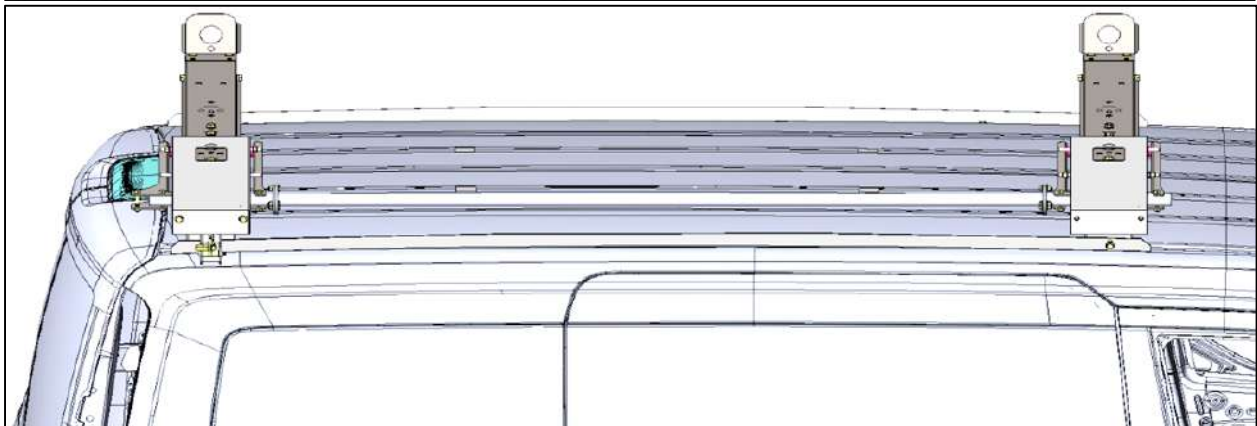
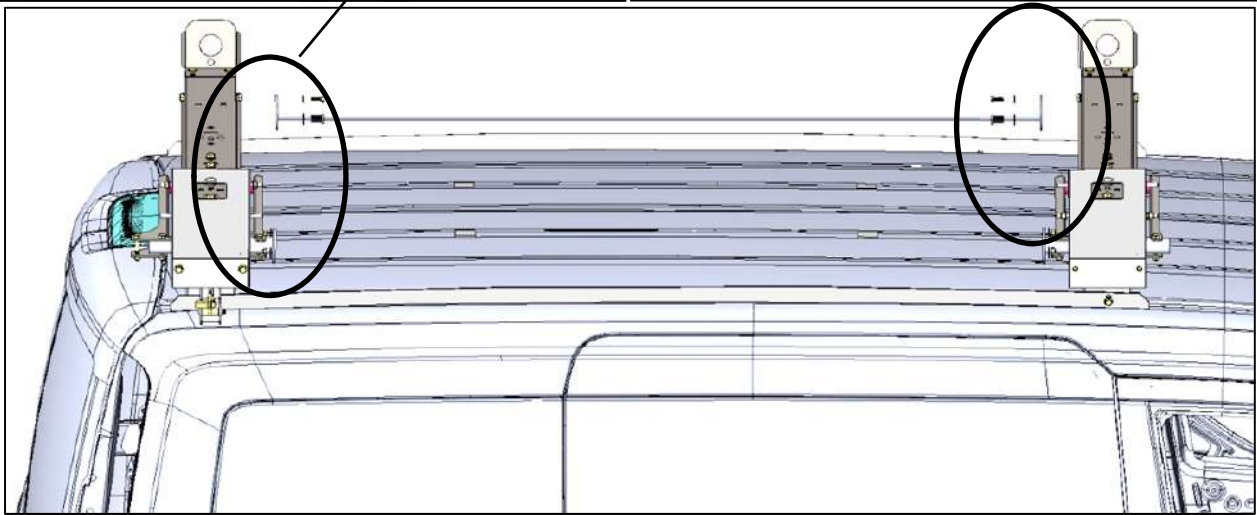
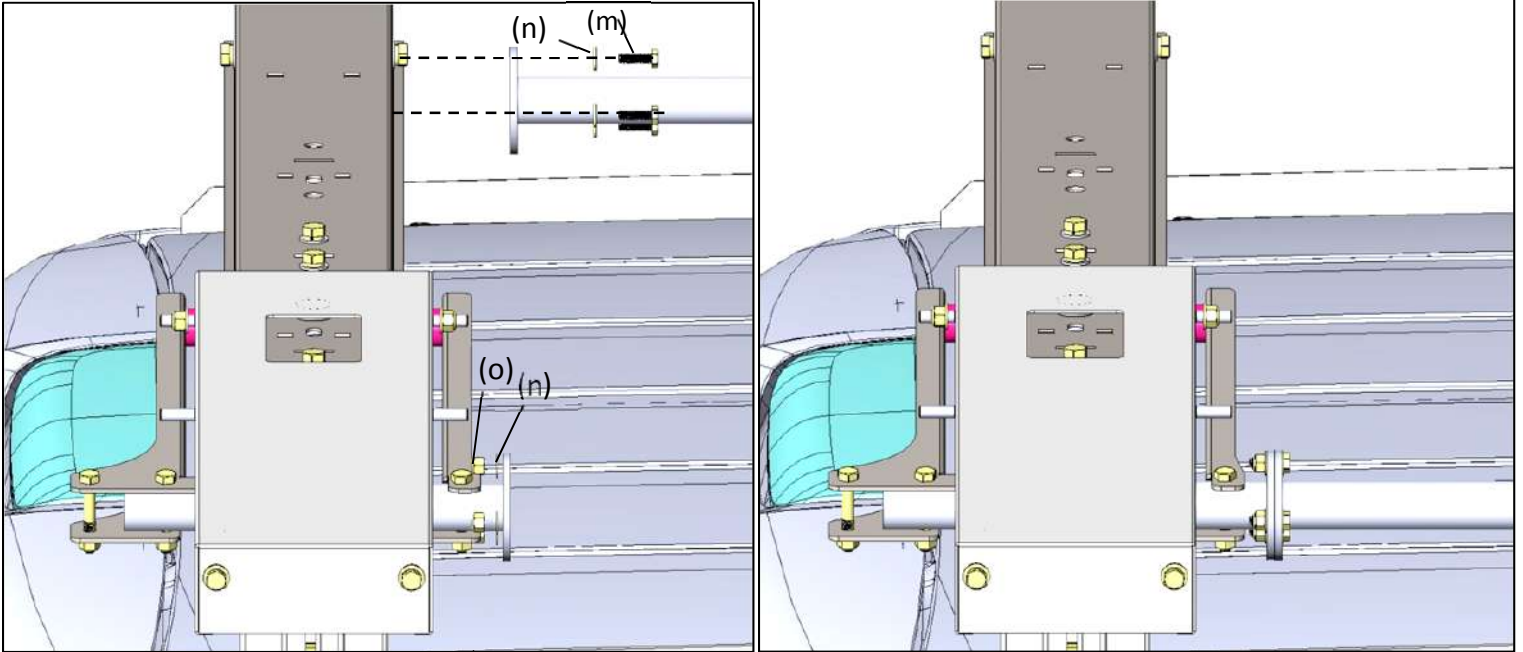

Step 8

Next bolt the "Handle Assy." Using 5/16"x2" bolts with a nyloc nut and flat washers as shown. BE SURE HANDLE WILL CLEAR THE REAR DOORS during operation. If it doesn't clear then the rails need to be mounted back farther on the van.

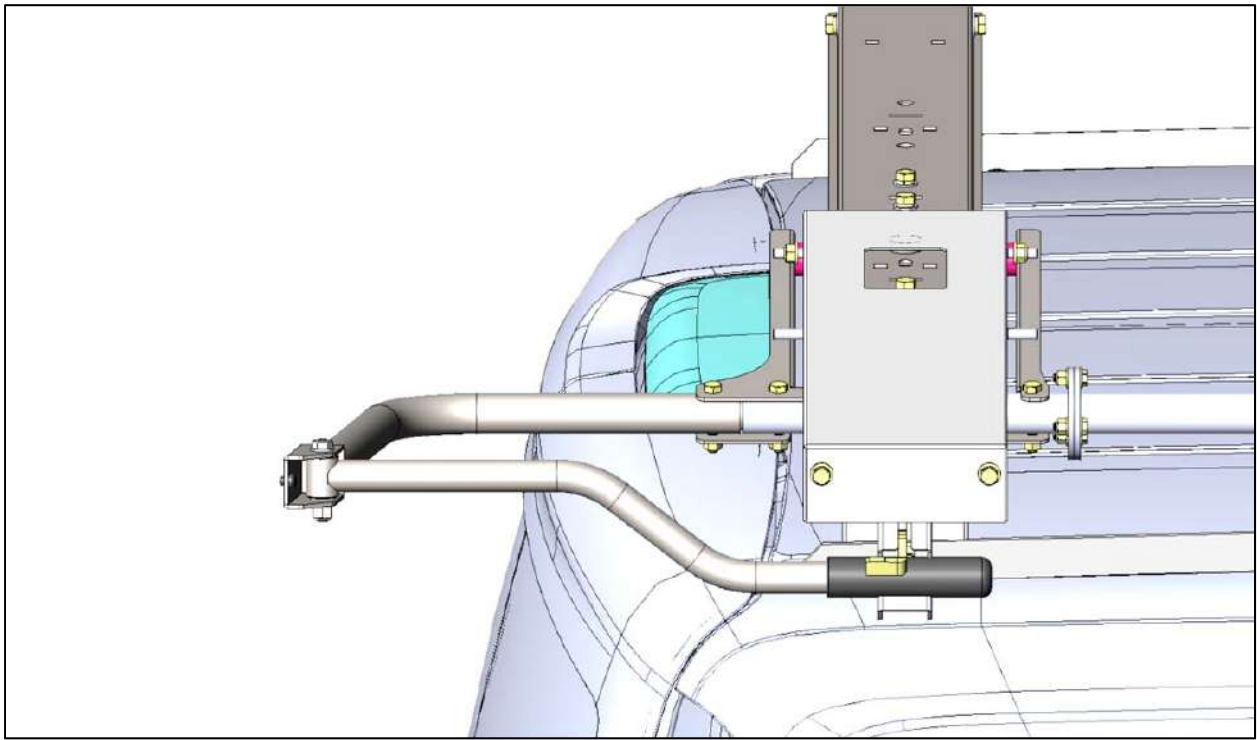
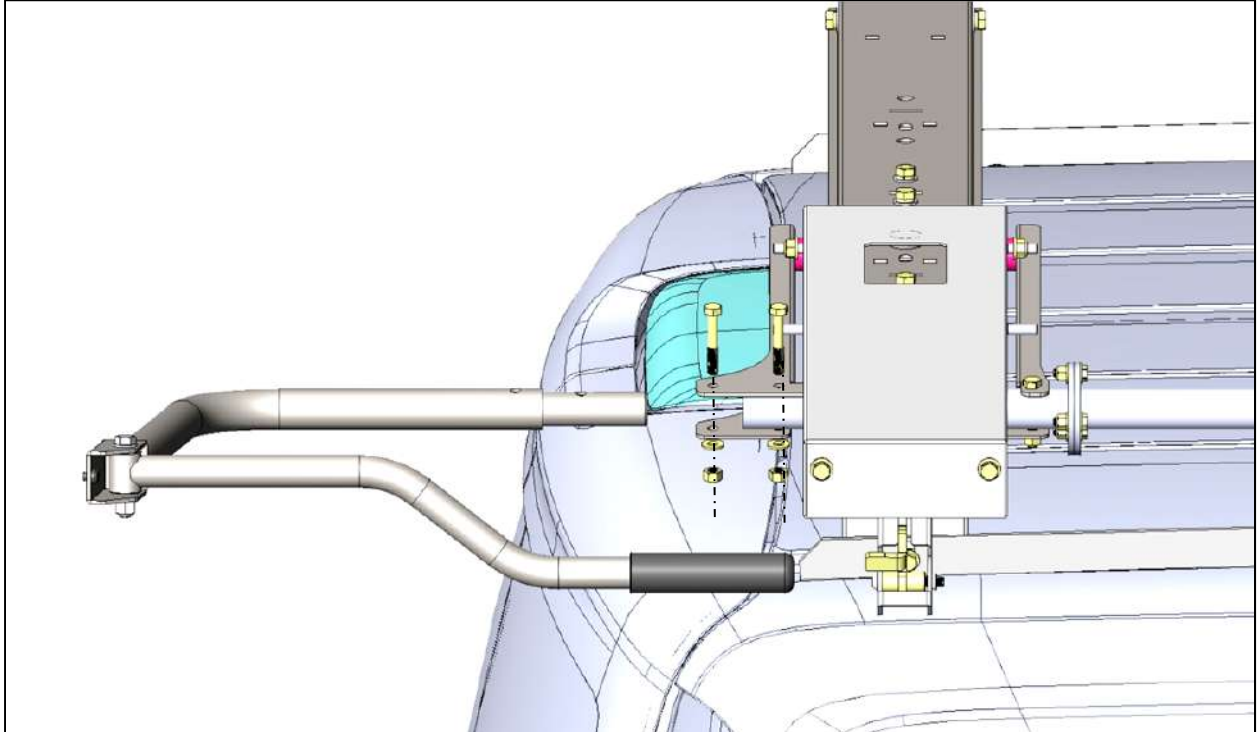

Step 9

Next attach the “Ladder Pan Stiffener” using 5/16”x5/8” bolts(e) with lock washer(c) and flat washers(b) as shown. With that completed you can now go back and tighten the feet to the rails and then the feet to the front and rear bow assemblies, double check the center to center dimension before tightening (71.5”).

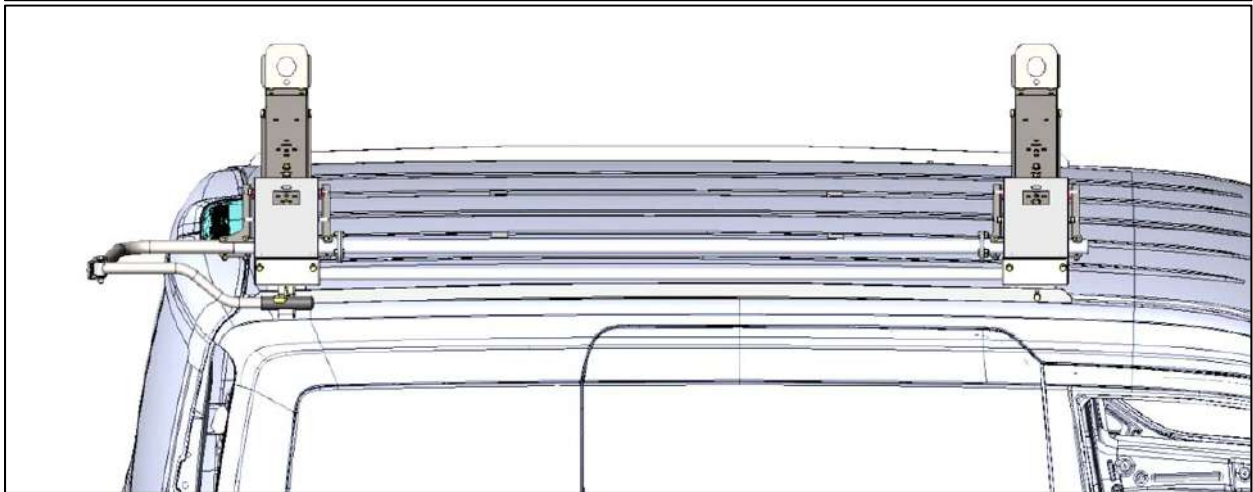
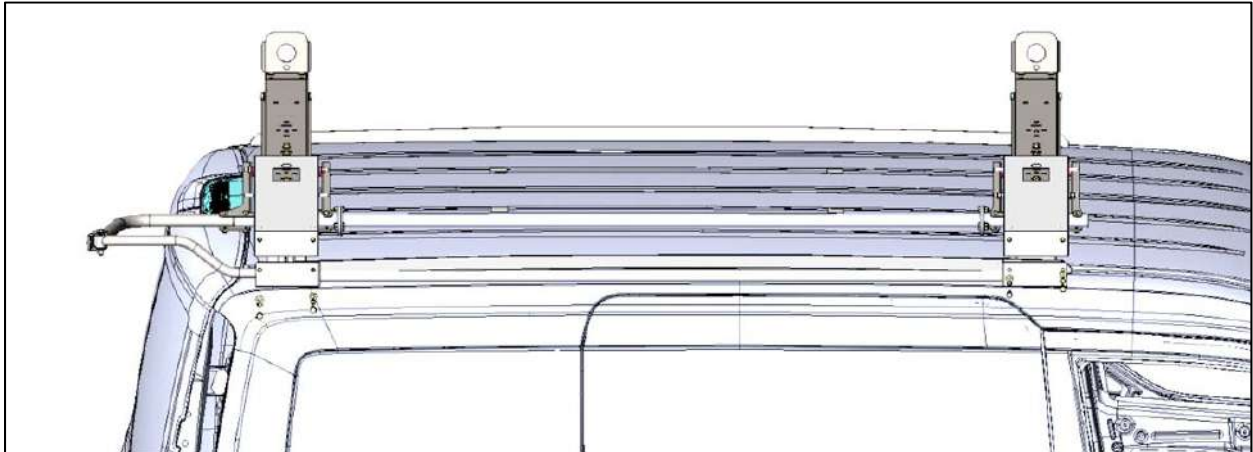
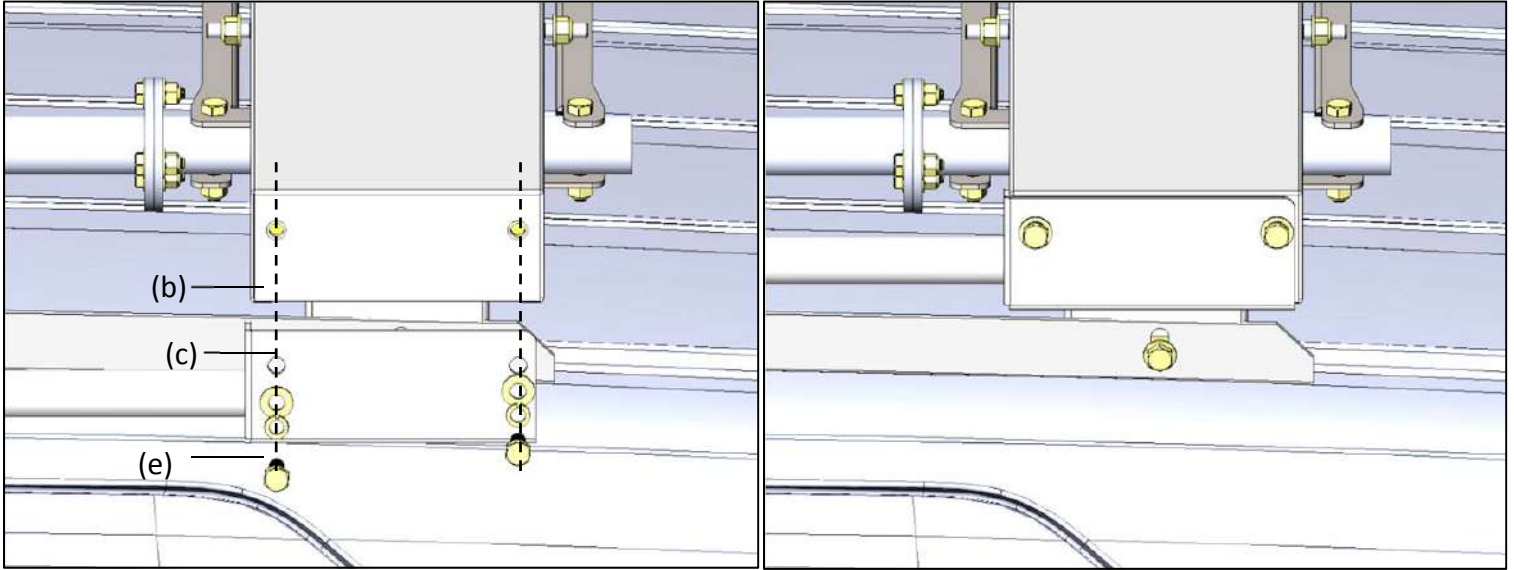

Step 10

Next attach the "Ladder Hooks" and "Ladder Stops". The first 4 pictures show the front hooks, the next 4 show the rear hook set in the "step ladder" location. If you are using an extension ladder use the same location as the front bow.

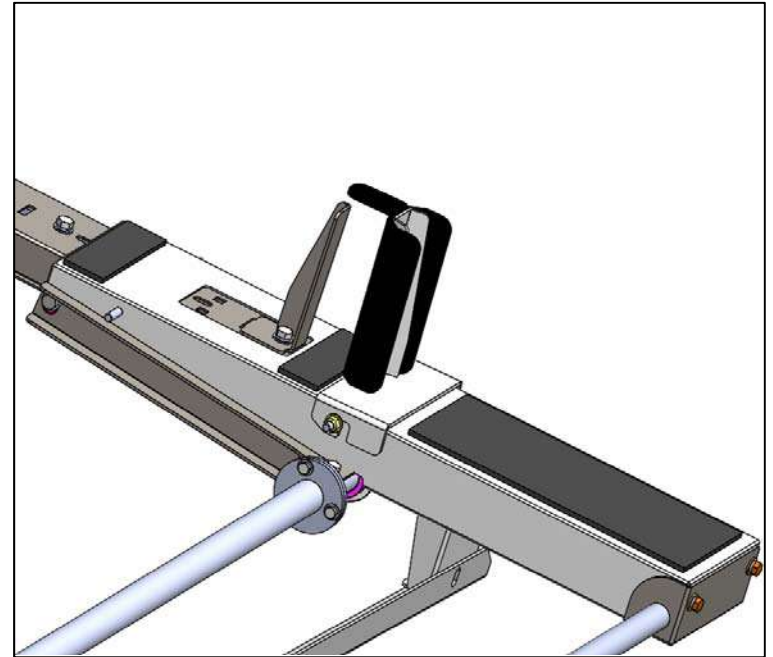
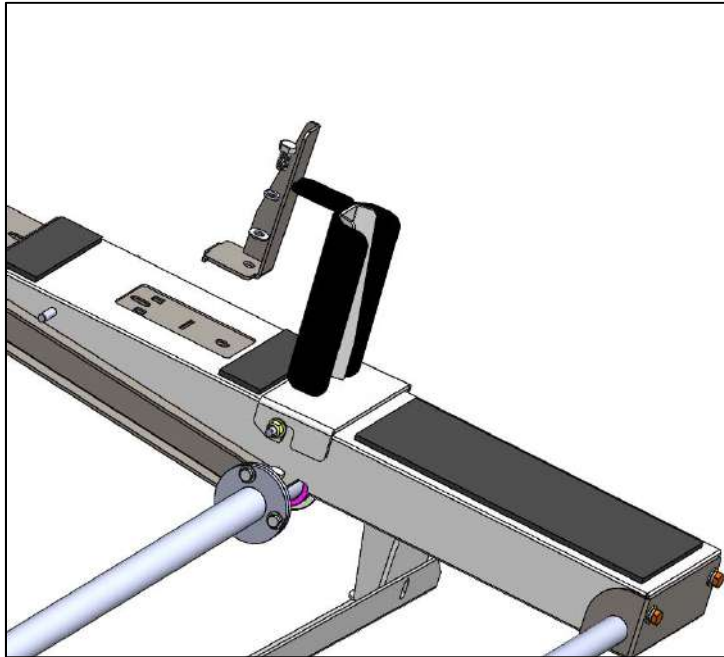
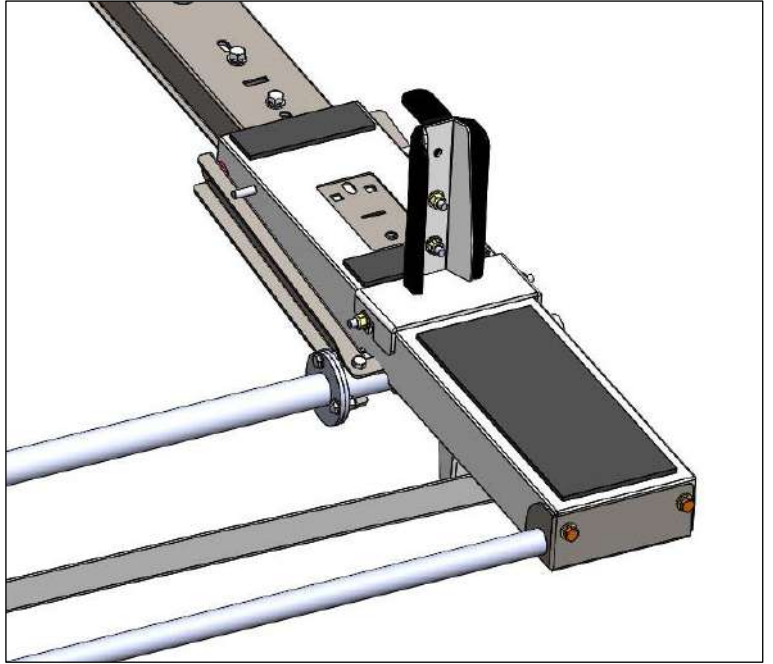
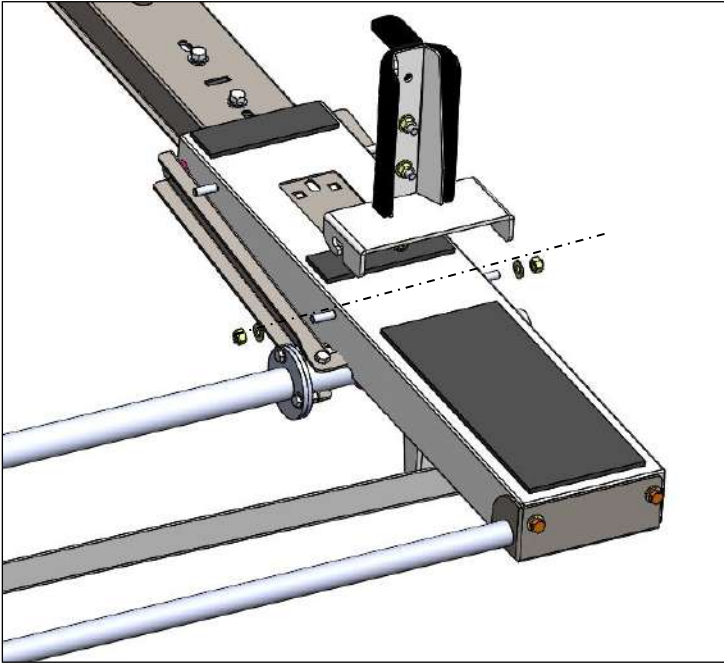

Rear bow location for step ladder.

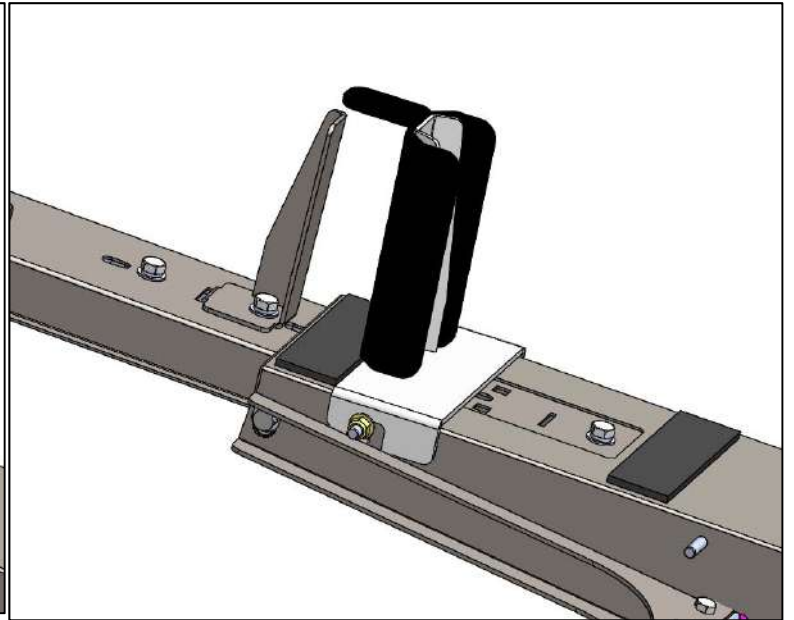
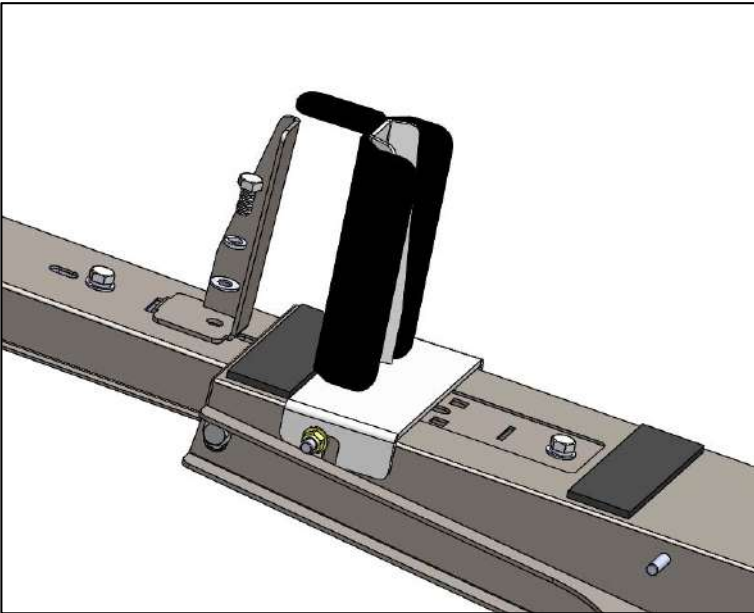
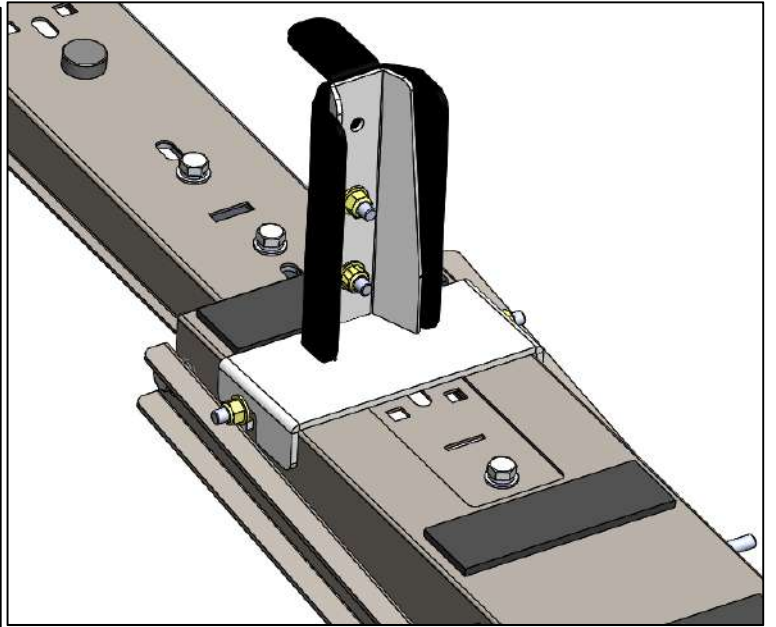
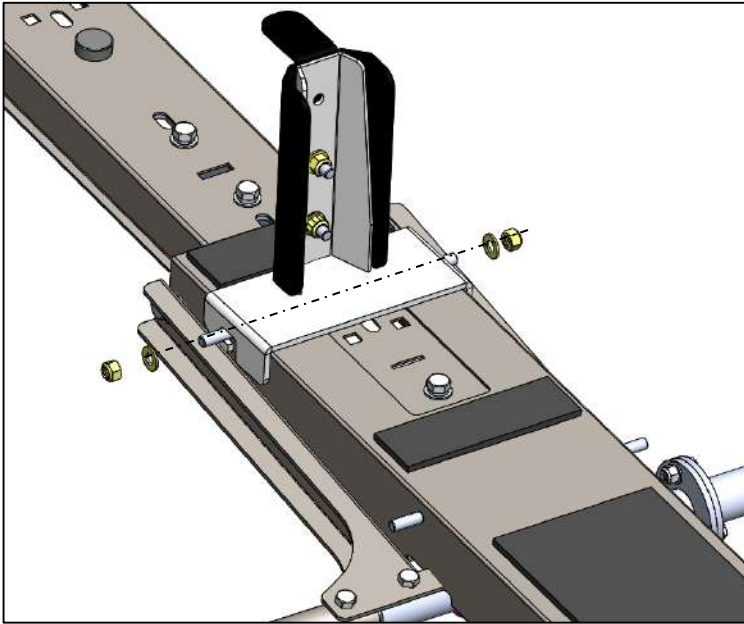

Installation complete for "step ladder".

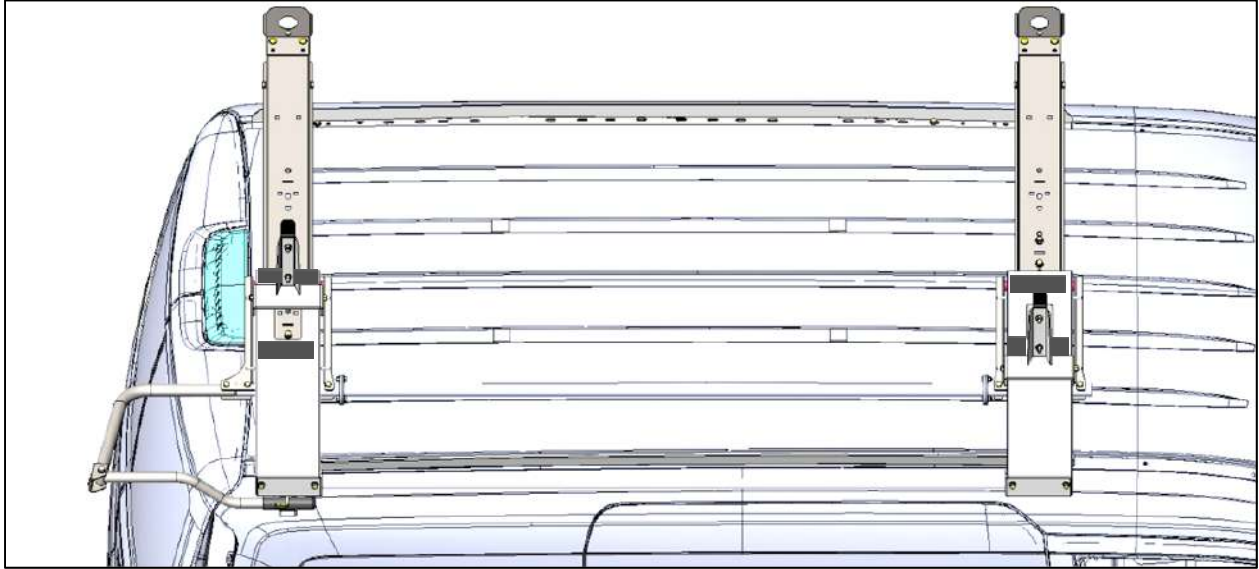

Installation complete for "extension ladder".

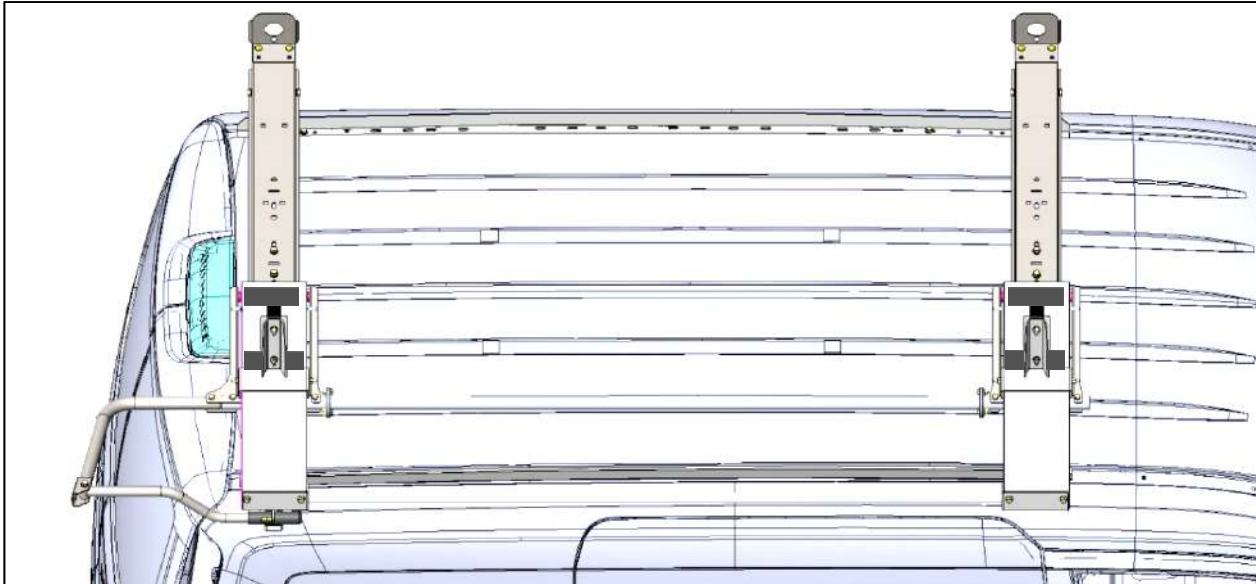



40963/40943 Parts List

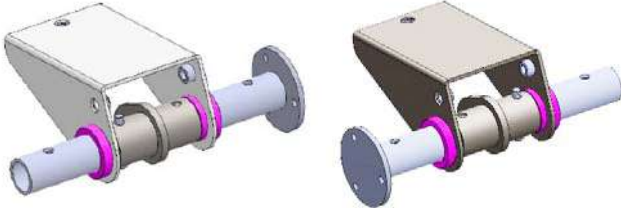

Front Torque Tube Pivot Assy. Rear Torque Tube Pivot Assy.

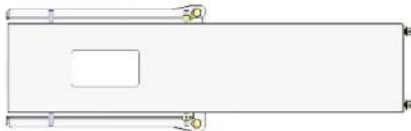

Front Ladder Pan Assy. (1)

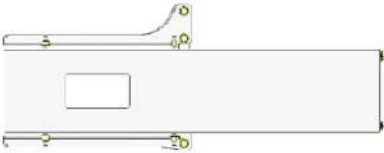

Rear Ladder Pan Assy. (1)



Latch(1) Ladder Hook(2) Ladder Stop(2) Dampener MntBrkt(2) Roller(4) Axle(2) Dampener(1)

No Dampener Mnt Brackets in 40943



Torque Tube (1)



Ladder Pan Stiffener (1)



Handle Assy. (1)

40963 40943 Hardware List

Tools Needed

8' Tape Measure

1/4" Socket

5/16" Socket

1/4" End Wrench

5/16" End Wrench

Hammer

Hardware Pack

(a)

Qty 2 -

5/16"-18 x 3/4" Carriage Bolt



(b)

Qty 10 -

5/16" Flat Washer



(c)

Qty 4 -

5/16" Lock Washer



(d)

Qty 6 -

5/16"-18 Nyloc Nut



(e)

Qty 4 -

5/16"-18 x 5/8" Hex Bolt



(j)

Qty 6 -

1/4"-20 x 7/8" Fully Threaded Hex Bolt



(k)

Qty 12 -

1/4" Flat Washer



(l)

Qty 6 -

1/4"-20 Nyloc Nut



(m)

Qty 1-

E6000



(n)

Qty 4-

3/8" Nylon Washer



(p)

Qty 2-

Nylon Spacer





40963/40943 Installation Instructions

Step 1

Bolt "Dampener mounting bracket" underneath the crossbow (both front and rear) as shown below using 3/8"x3/4 Bolts with flat and lock washers.

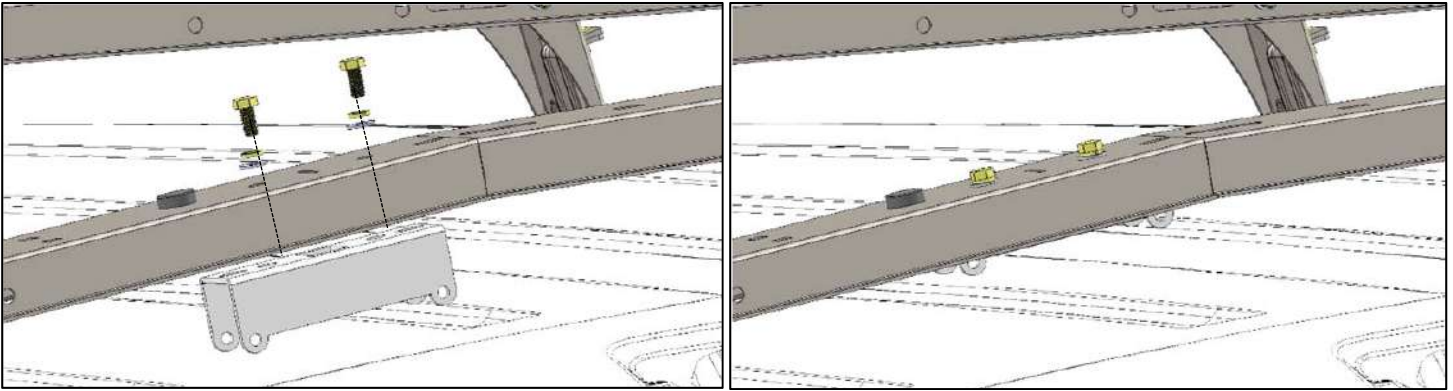

Step 2

Bolt "Torque tube pivot Assy." underneath the crossbow (both front and rear) as shown below using 3/8"x3/4 Bolts with flat and lock washers. Be sure to have the 3 hole flanges facing each other (rear bow shown). You may need to detach the feet and lift the crossbow slightly to get into place.

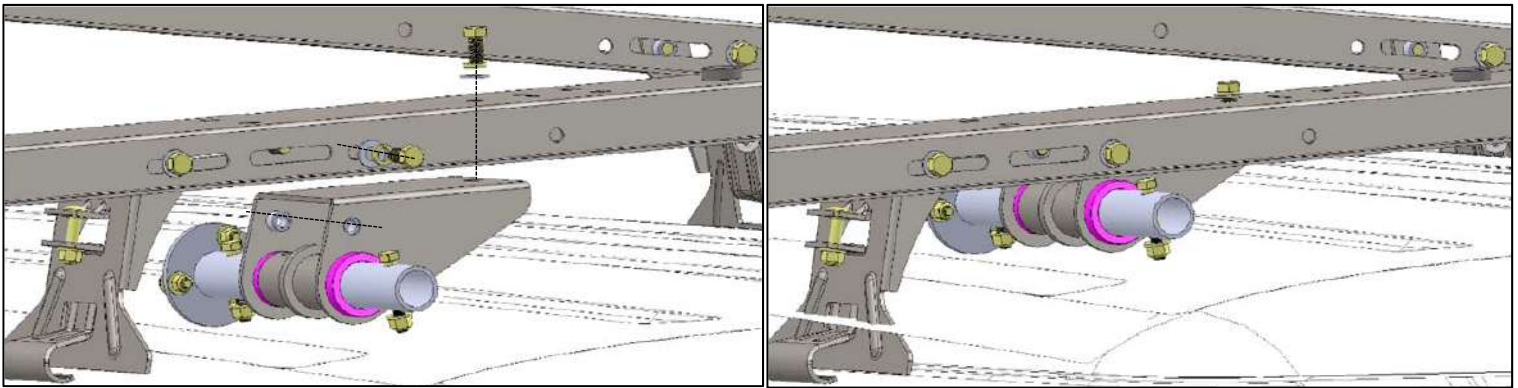

Step 3

Attach the "Torque Tube" between the flanged plates on the "Torque Tube pivot Assy." Using 1/4"x7/8" bolts as shown below. Be sure the "Torque Tube pivot Assy." are lined up prior to bolting them together. You can now re-attach the feet.

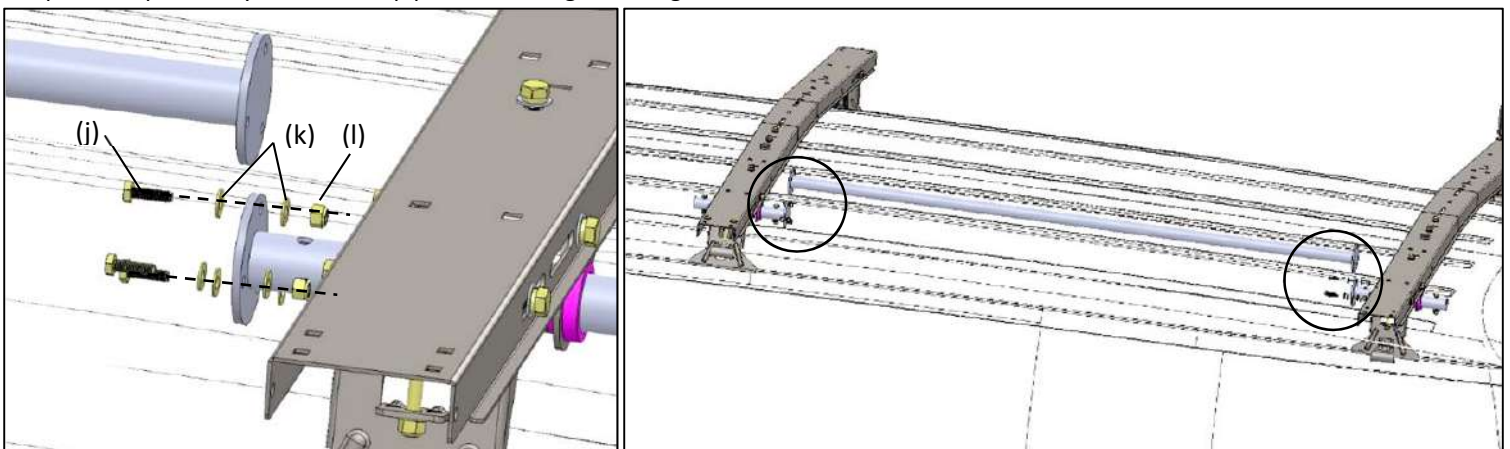

Step 3 continued.

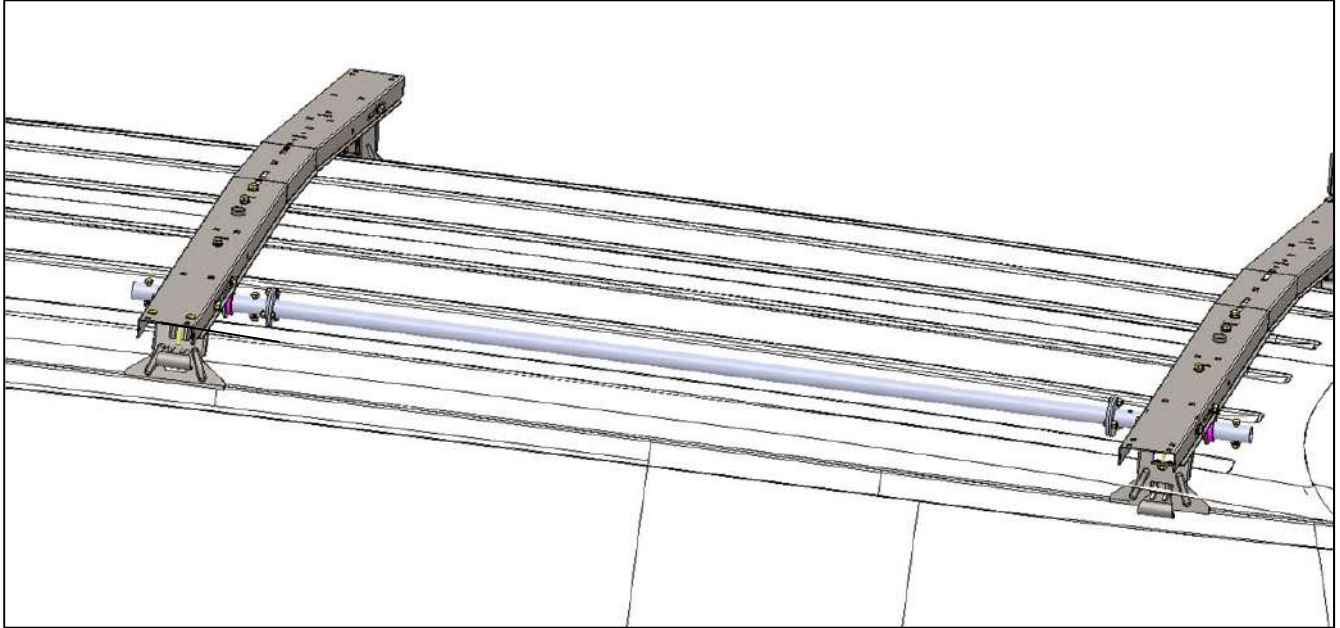

Step 4

Next attach the "Dampener" to the rear bow assembly. Make sure the "Torque Tube Pivot Assy." is rotated so the cam is pointed towards the center of the van. Attach the shaft end of the "Dampener" to the cam using the 5/16" pin, make sure the cotter pin is secure. Now attach the body end to the "Dampener mounting Bracket" using the 5/16"x2 1/4" pin, sandwich the nylon spacer (p) to secure the dampener in the middle of the bracket.

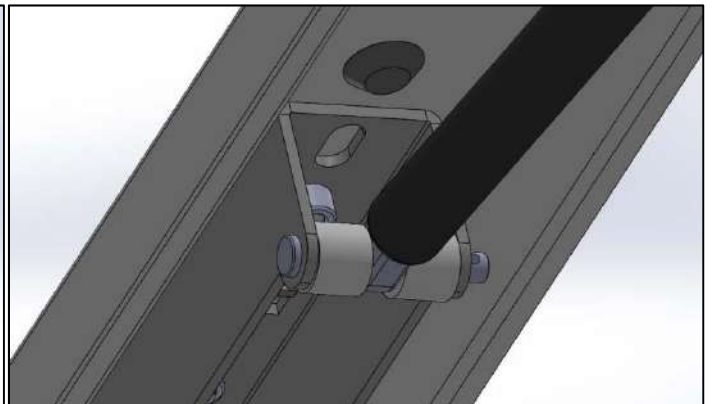
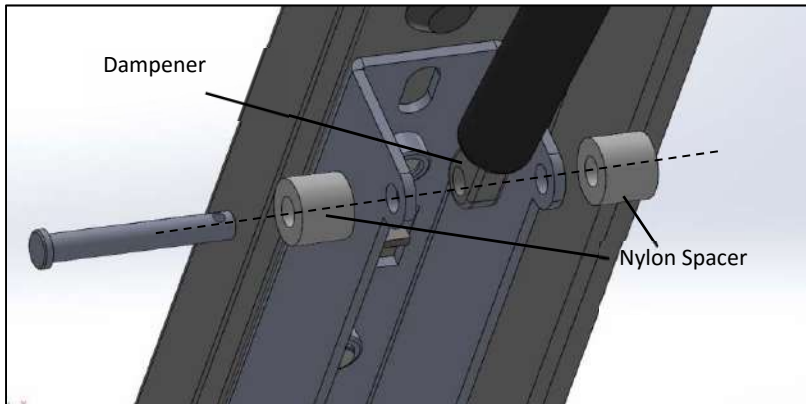
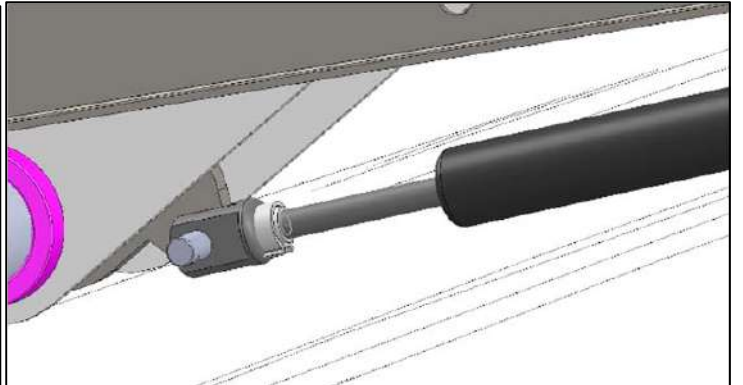
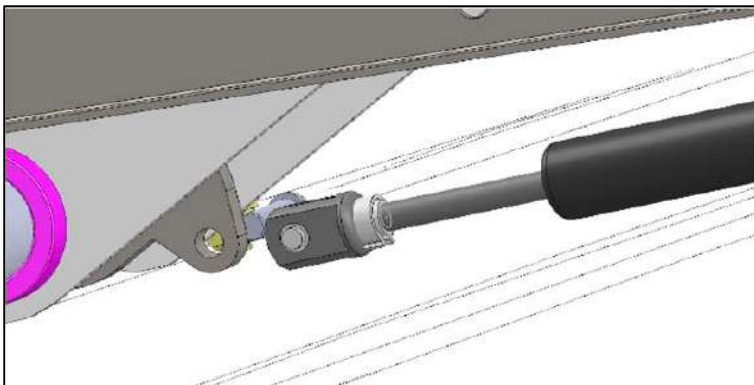

Step 5

Attach the "Latch" To the rear bow assy. as shown below using 5/16"x3/4" carriage bolts(a) with flat washers(b) and nylock nuts(d).

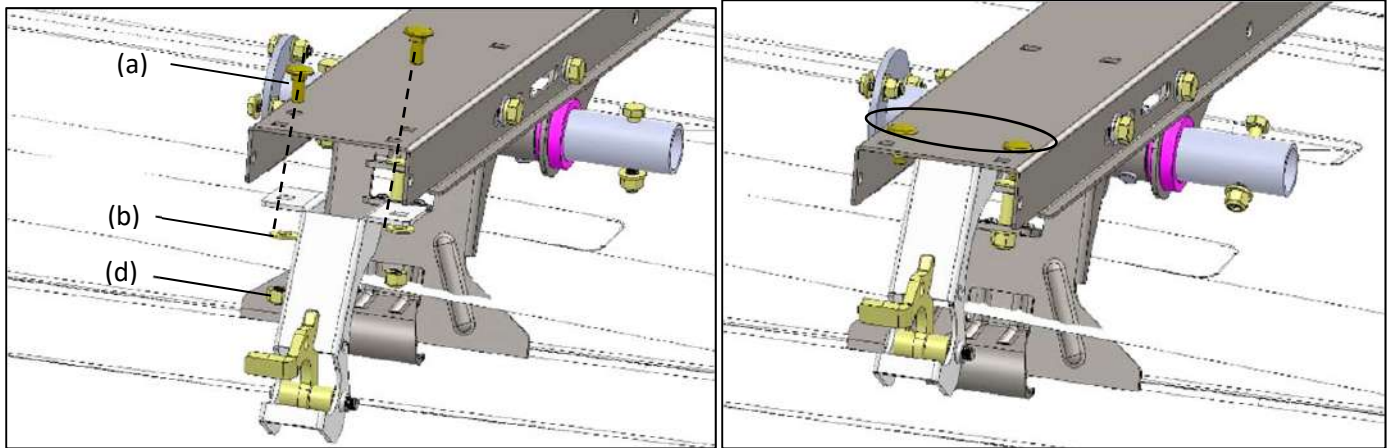

Step 6

Next install the "Axles" and "Rollers" at the end of both front and rear crossbow. The "Axle" just slides in and the "Rollers" slide over the ends of the "Axle" as shown below, make sure insert the nylon washers(n) between the wheels and crossbow.

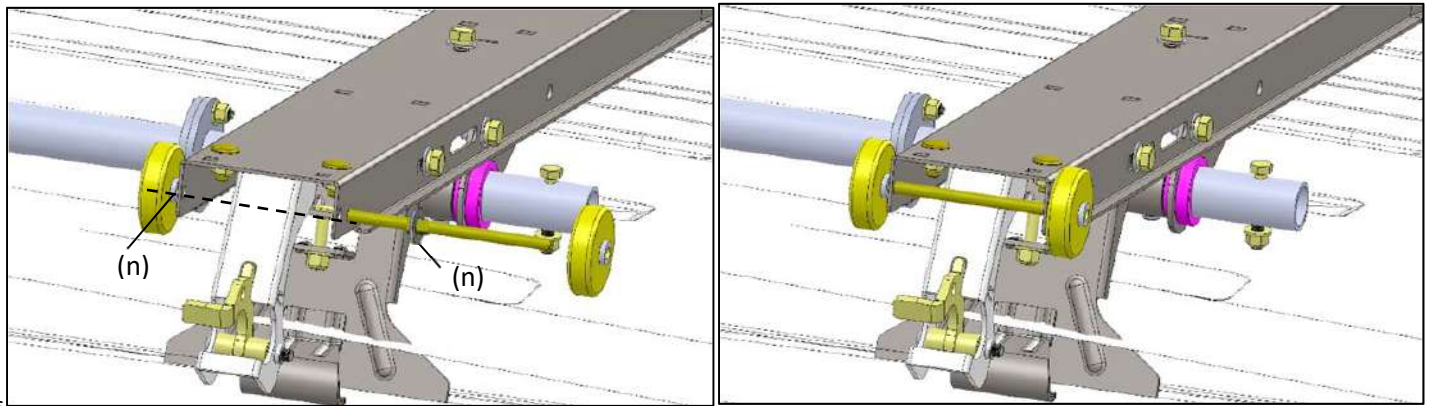

Step 7

Next install the "Ladder Pan Assy." Align cutouts in "Ladder Pan Assy." with the "Rollers" and guide the arms onto the "Torque Tube Pivot Assy." As you lower the assembly onto the rollers. Insert 5/16"x 2" bolts with flat washer and nylock nuts through arms and "Torque Tube Assy." Make sure the "Rear Ladder Pan Assy." is on the rear crossbow.

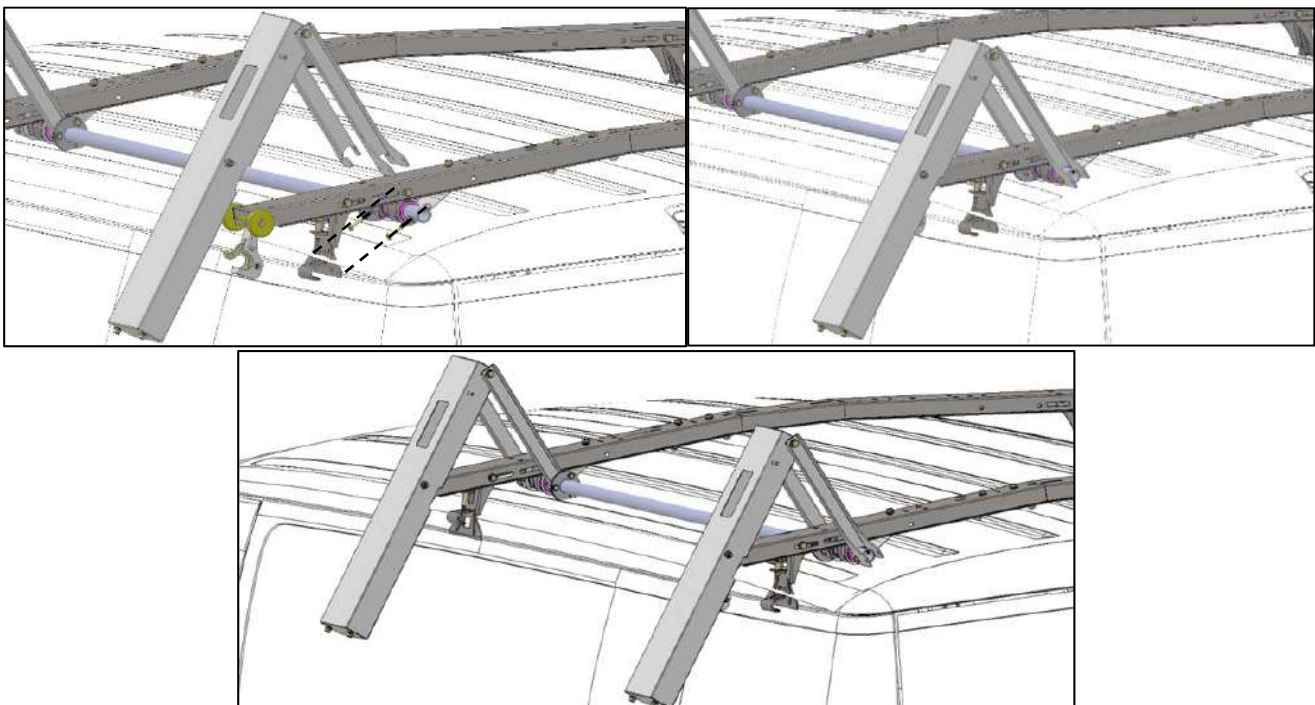

Step 8

Install handle assembly, use E6000 on 5/16" x 2" bolts to keep water out of the tube. Be sure handle will clear the back of the van.

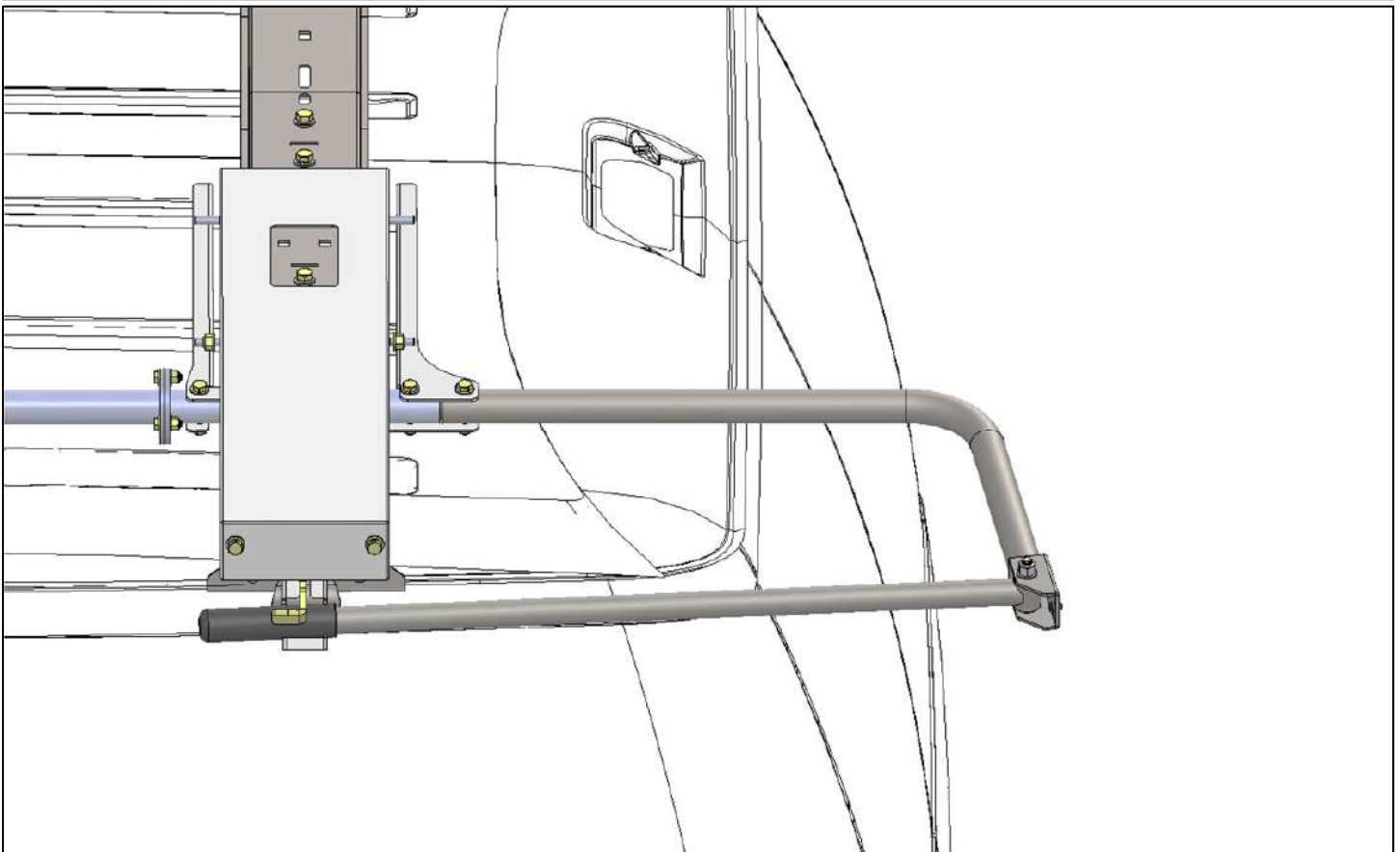
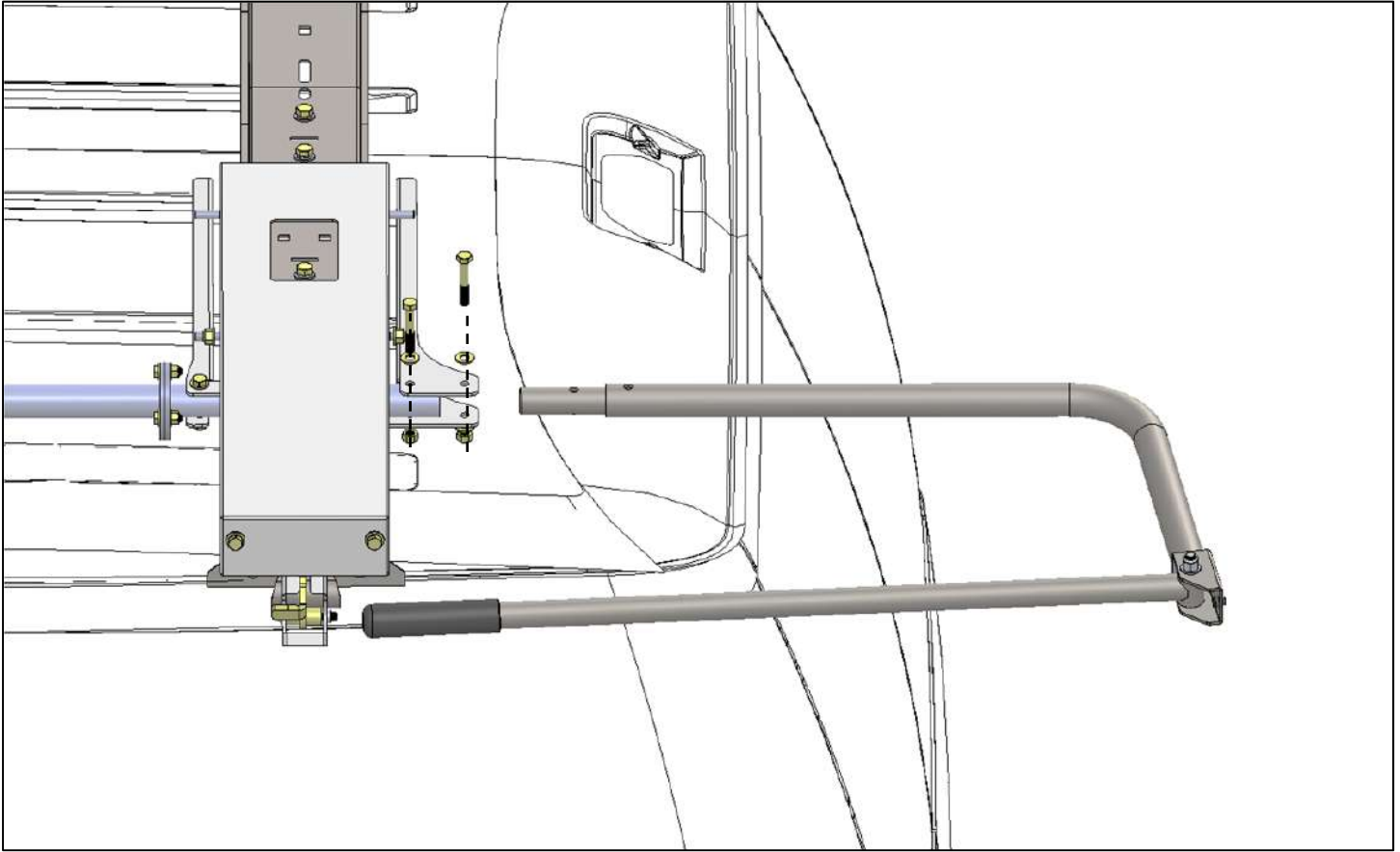

Step 9

Attach ladder pan stiffener, in the closed position, using 5/16" x 5/8" bolts (e) with lock washers (c) and flat washers (b).-

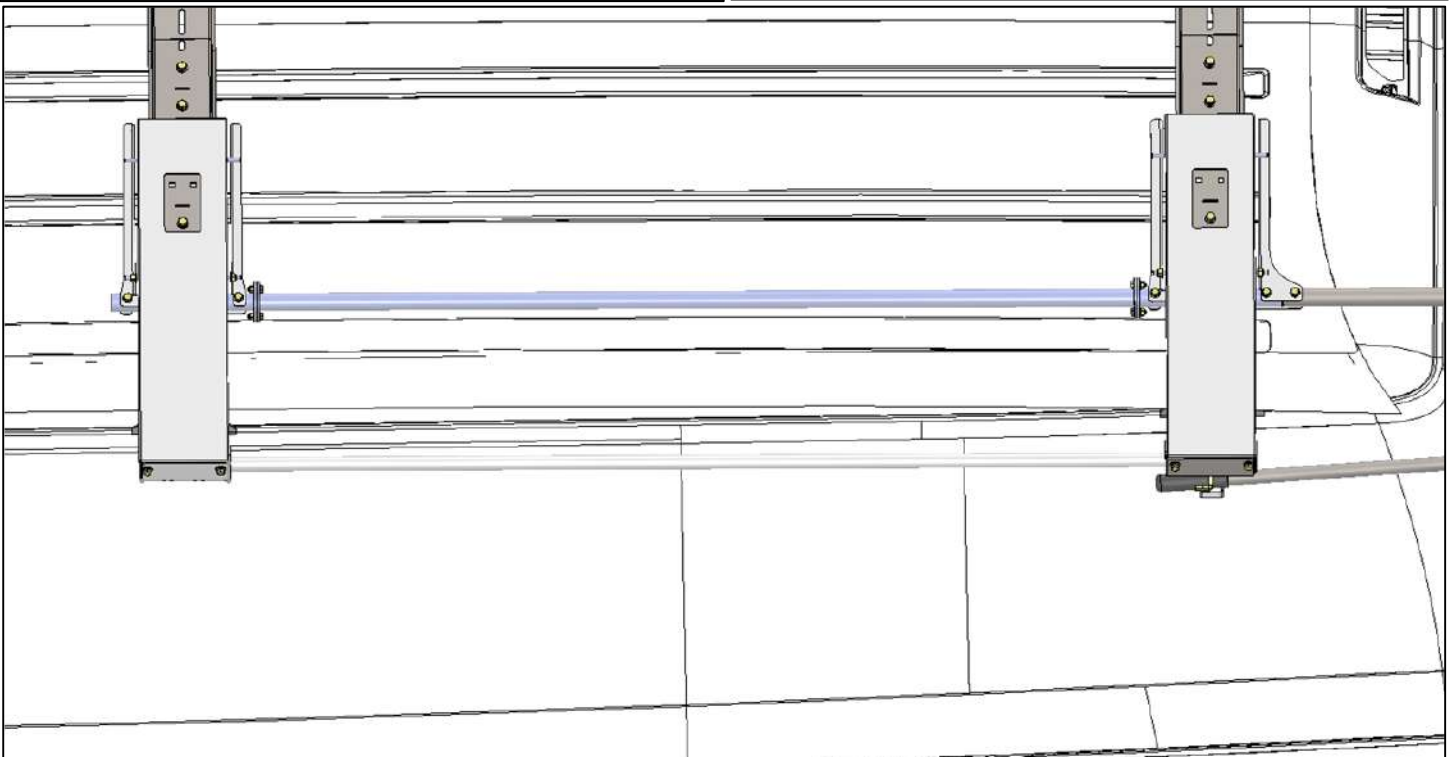
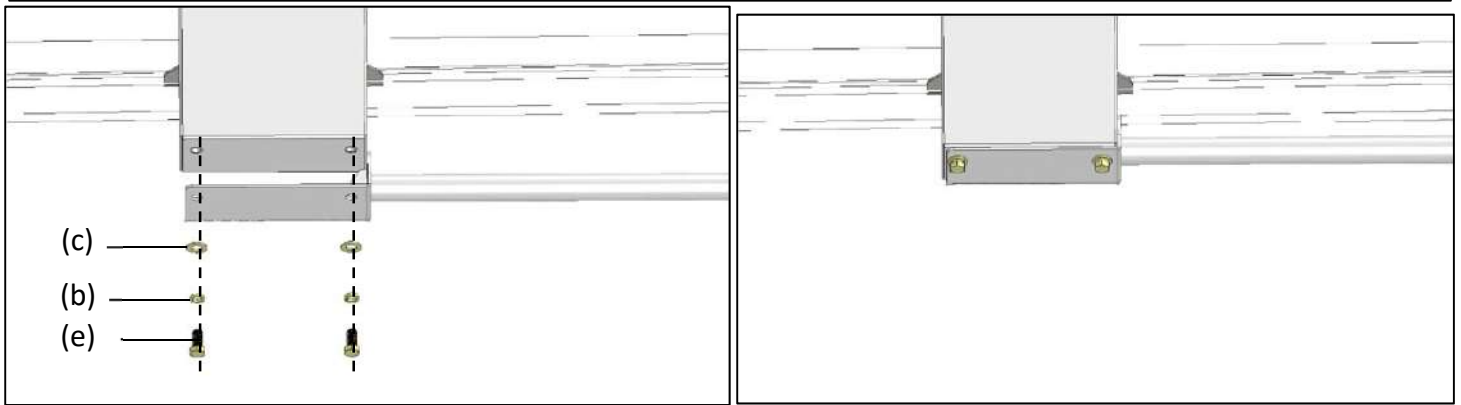
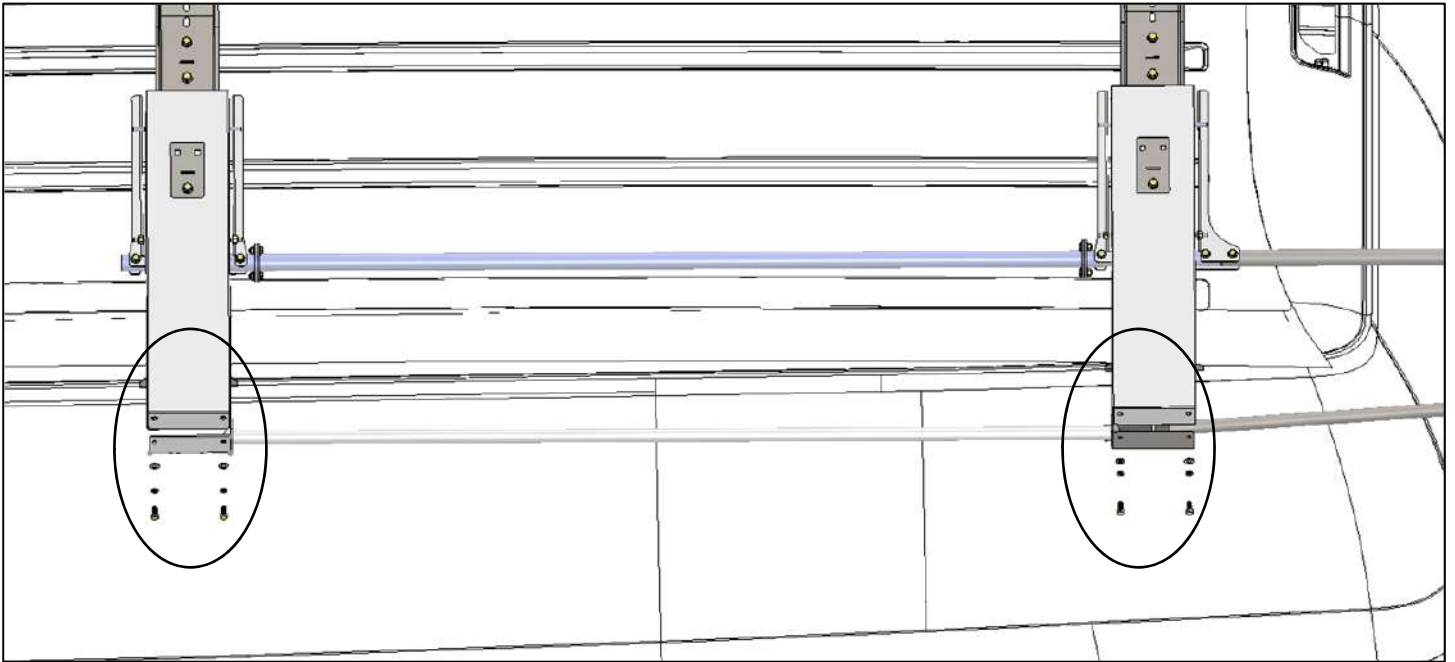

Step 10

Attach ladder hooks to ladder pans on 5/16" studs in desired location (Diagram A). Attach ladder stops to coincide with ladder hooks by removing 3/8"x3/4" bolt and placing stop so the tab on the stop goes into the corresponding slot. The diagram below shows in the lower position commonly used for extension ladders. You can install in the upper position in the rear for step ladders (as shown in last view).

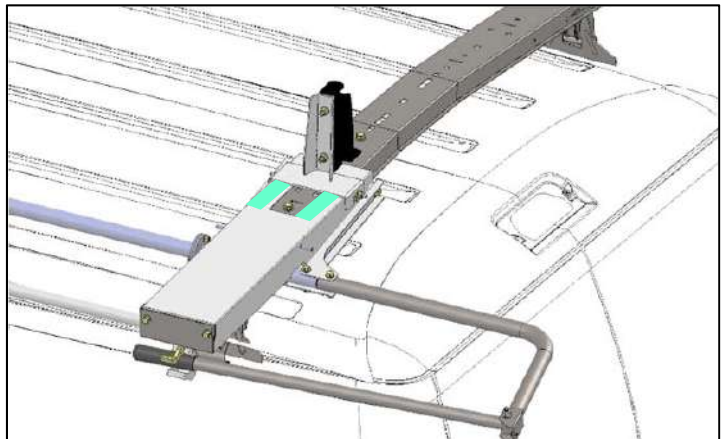
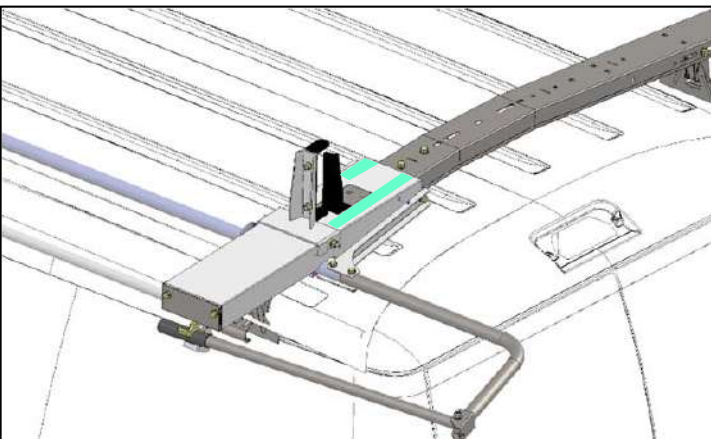
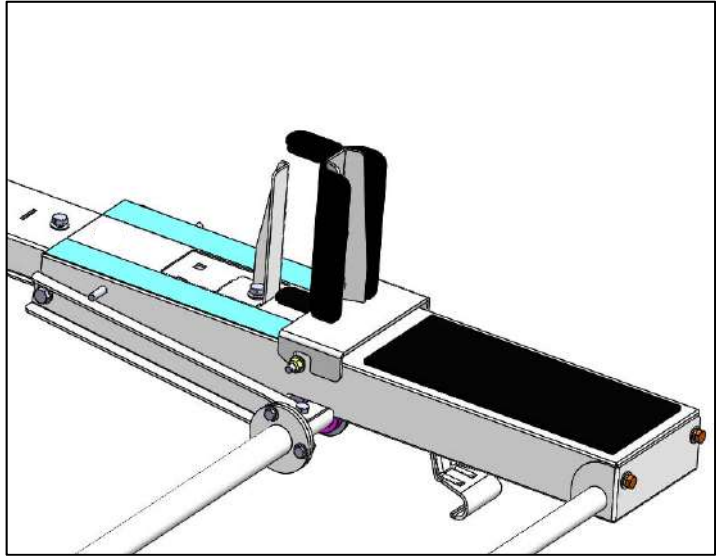
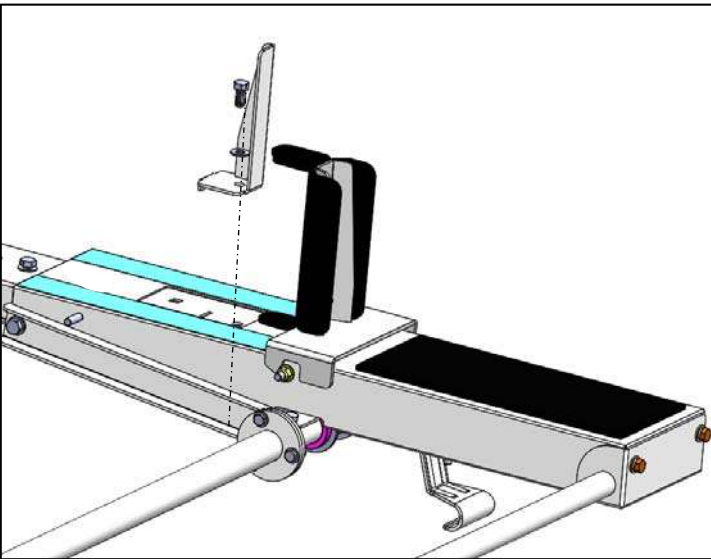
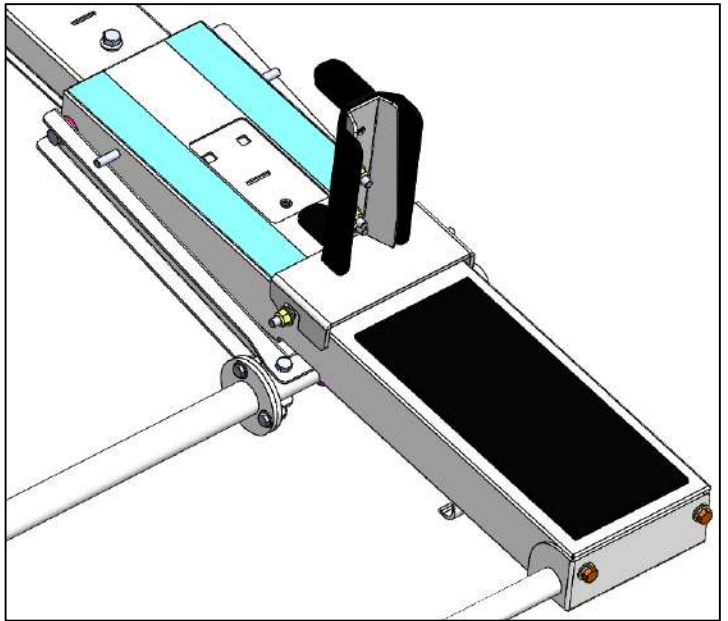
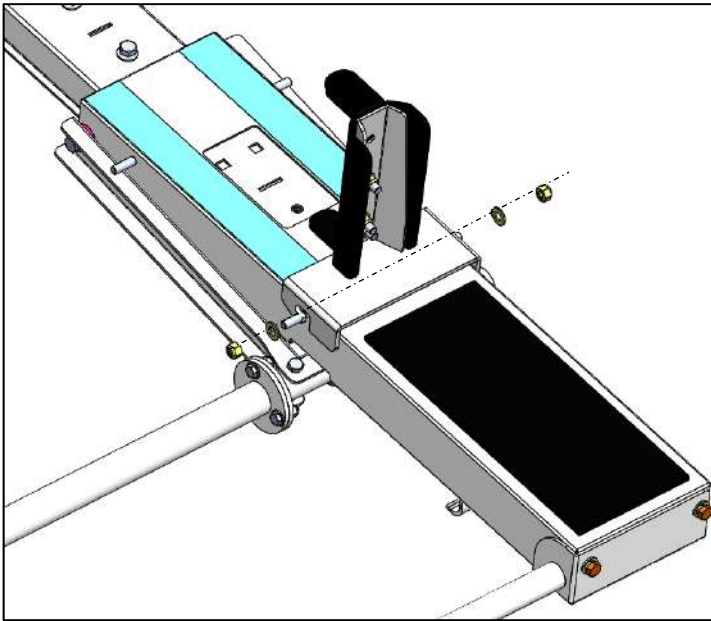

Installation Complete for Extension Ladder

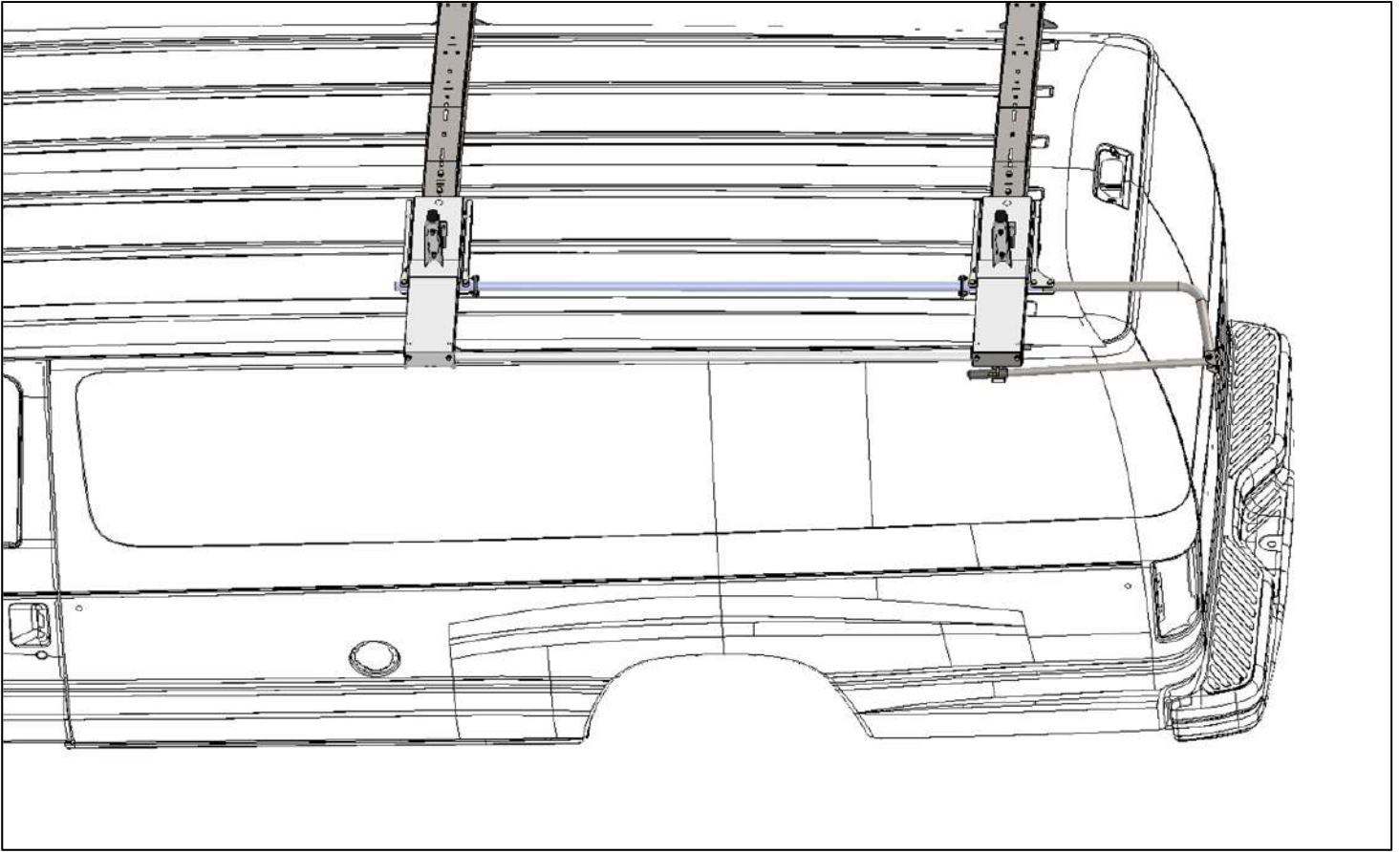

Installation Complete For Step Ladder

