

KARGO MASTER[®]

WE PUT EVERYTHING WITHIN REACH.

Instruction Guide

4A80L

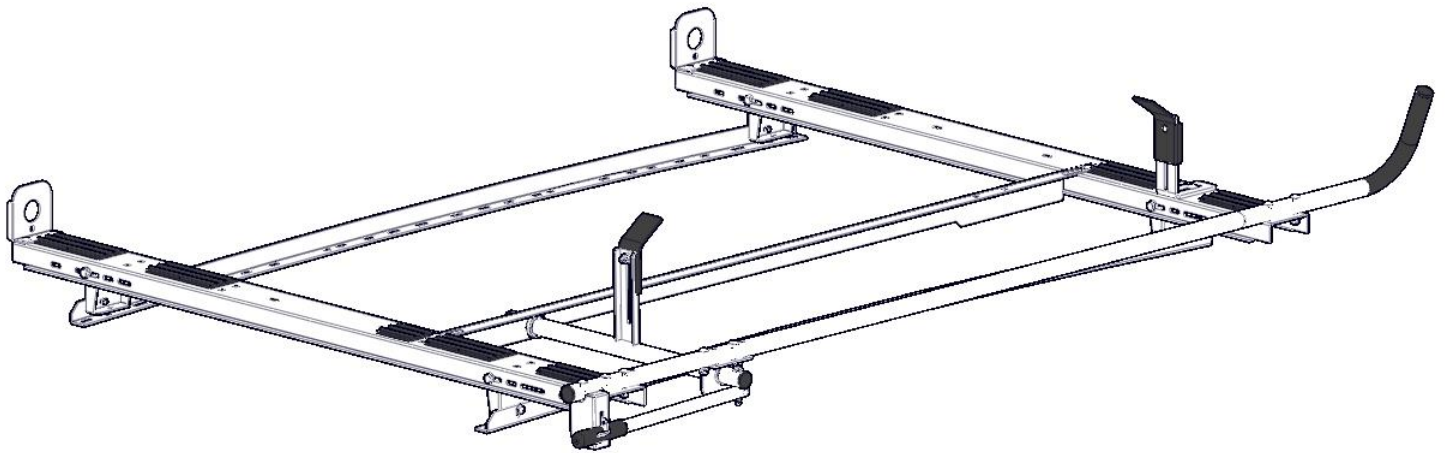

***PLEASE READ ALL INSTRUCTIONS AND WARNINGS PRIOR TO ASSEMBLING,
INSTALLING, AND USING THIS PRODUCT***

Warning



Always check for wires, fuel tanks and lines, brake lines and other important vehicle functionality items prior to drilling and installing all products.









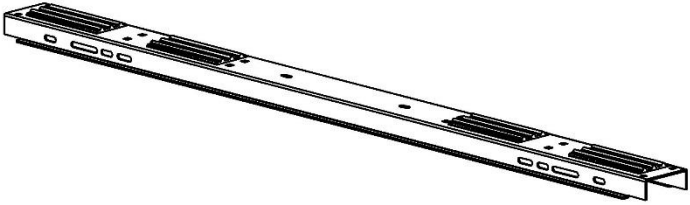
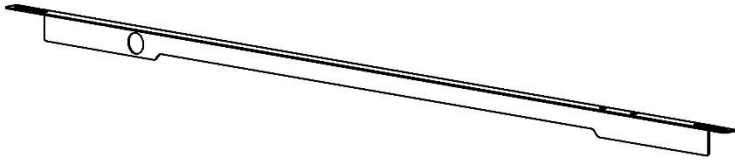

Tools Needed

13mm Socket and Wrench	10mm Socket and Wrench
5mm Allen Hex	9/16" Socket and Wrench
7/16" Socket and Wrench	1/2" Socket and Wrench

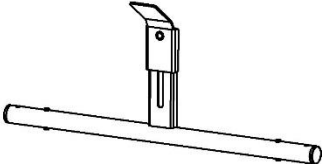

Before You Begin

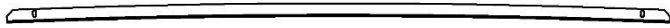
- Read all instructions. Find your vehicle roof rail mounting prior to rack assembly.
 - Be sure to put sealant around all threads entering cargo area and between the rubber spacer and roof of vehicle to prevent water from leaking into cargo area.
 - Rubber pads on bows may vary, but installation is the same.
 - **DO NOT EXCEED MANUFACTURERS WEIGHT CAPACITY FOR ROOF**
-

Parts

ITEM NO.		PART NUMBER	DESCRIPTION	QTY.
A		4A800-00-001-R3	Cross Bow	2
B		4A800-00-003-R3-R	Clamp and Lock L Bracket	1
C		4A800-50-001-R3	Side Tube	1
D		4A800-50-002-R2-R	Side Hook	1
E		4A800-00-004-R1	ladder stop	2
F		11-03027A	Angle BRK	1
G		4A800-30	Clamp Tube	1
H		4A800-20	Latch Assy.	1
J		4A800-40	Handle	1
K		4A800-60	Ladder Stop Assembly	1
L		4A800-00-002	Mounting Rail	2
M		4A800-10	Foot	4
		18-4A800	Hardware	1
		4A80L Mounting Kit	Mounting Hardware	1

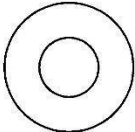
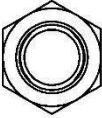
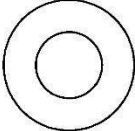
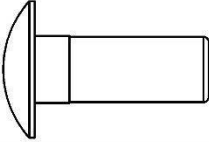
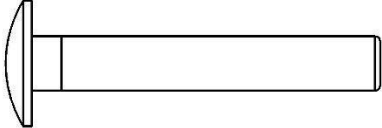
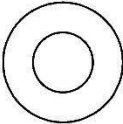

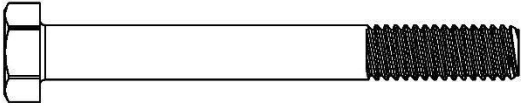
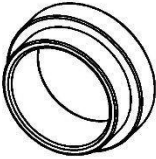
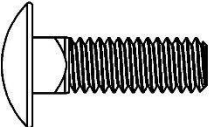
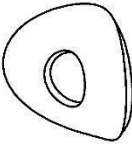
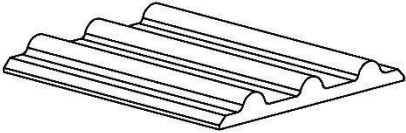

Hardware (18-4A82L)

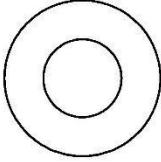
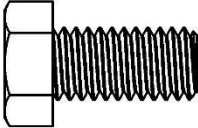
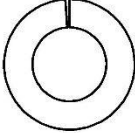
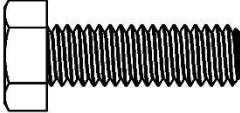
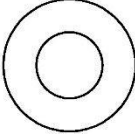
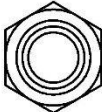
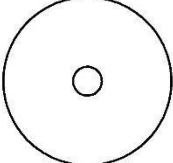
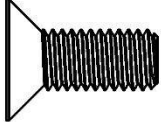
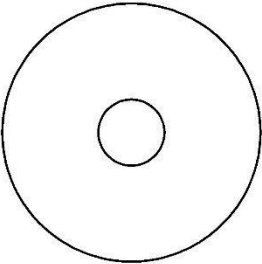
ITEM NO.	TO SCALE	PART NUMBER	DESCRIPTION	QTY.
1		90295A160	.06x.34x.75 Nylon Washer	2
2		.375-16 NYLOC	3/8-16 Nyloc Nut	3
3		.375 FLAT WASHER	3/8 Flat Washer	3
4		.375-16 x 3/4 Carriage	3/8-16x3/4 Carriage Bolt	3
5		.312-18x2.0 CARRIAGE BOLT	5/16-18x2.0 Carriage Bolt	7
6		96659A107	5/16 FLAT WASHER	11
7		91831A030	5/16 NYLOC	12
8		.312-18 X 2.75 HEX BOLT	5/16-18x2 3/4 Hex Bolt	1
9		40800-10-007	PLASTIC BUSHING 1:2 SCALE	2
10		90185A583	5/16 x 1 CARRIAGE	4
11		91844A230	5/16 CONTOUR WASHER	1
12		Extra Rubber Pad	1:2 SCALE	1

Hardware (18-4A80L)

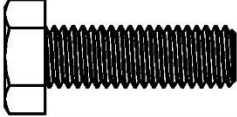
ITEM NO.	TO SCALE	PART NUMBER	DESCRIPTION	QTY.
1		90126A031	3/8" Flat Washer	8
2		92865A622	3/8"-16 x 3/4" Hex Head	8
3		91102A760	3/8" Split Lock Washer	8
4		92865A583	5/16"-18 x 1" Hex Head	4
5		90126A030	5/16" Flat Washer	12
6		95615A160	5/16"-18 Nyloc	4
7		RUBBER WASHER SCALE 2:1	1/8" T x 5/16" ID x 1-3/4" OD Rubber Washer	6
8		91263A844	M8x1.25 x 20mm Flat Head	4
9		5/16 Fender Washer	OVERSIZE WASHER	4

Continued

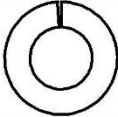
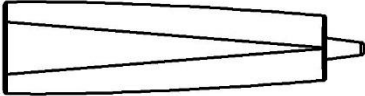
ITEM NO.	TO SCALE	PART NUMBER	DESCRIPTION	QTY.
10		93625A300	M8 Nyloc Nut	4
11		91287A153	M8 x 25mm Hex Head	4
12		91287A137	M6 x 20mm Hex Head	6
13		93475A250	1/4" Flat Washer	6
14		92148A180	1/4" Split Lock Washer	6
15		91102A755	5/16" Split Lock Washer	12
		BH-821	Sealant	1

DO NOT EXCEED MANUFACTURERS WEIGHT CAPACITY FOR ROOF

Promaster City Installation

- Locate 6 mounting locations shown on roof of van.
- Install mounting rail as shown using M6x20mm bolts with lock washers and flat washers.
- In most installs, the rail upright is to the outside of the van.
- Be sure to put rubber washer between the mounting rail and the roof to ensure sealing.
- Place sealant on and around threads to seal roof. (Passenger side shown)

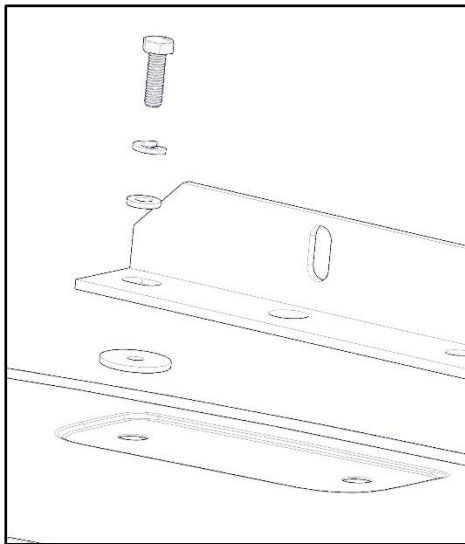
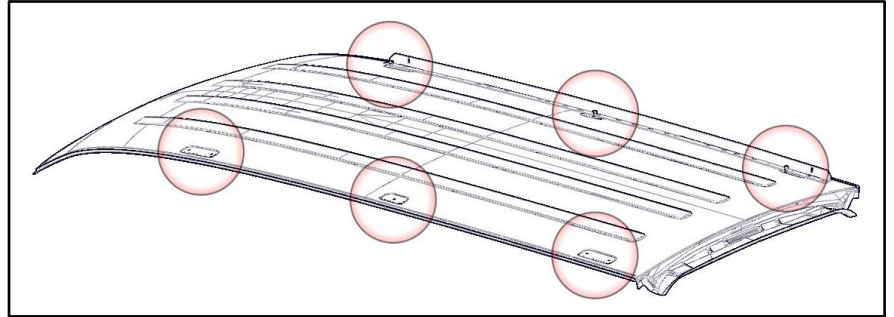

Front EXP

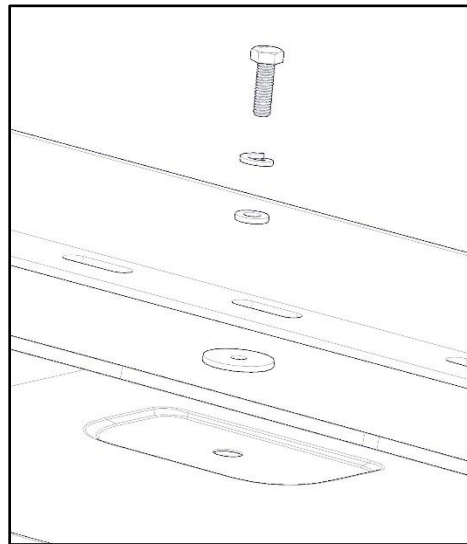

Mid EXP

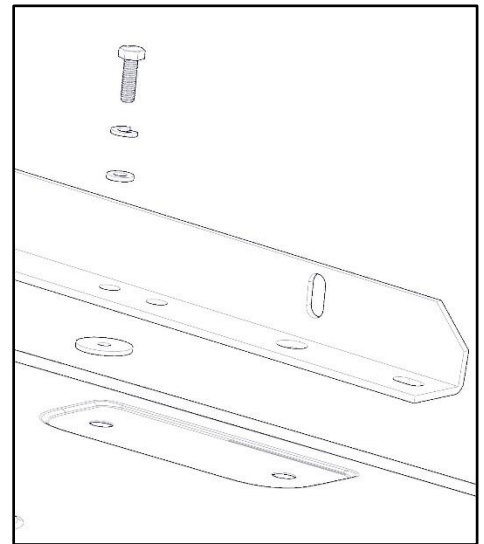

Rear EXP

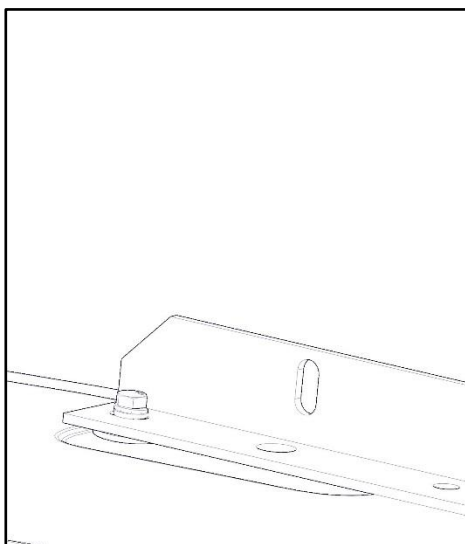

Front Tighten

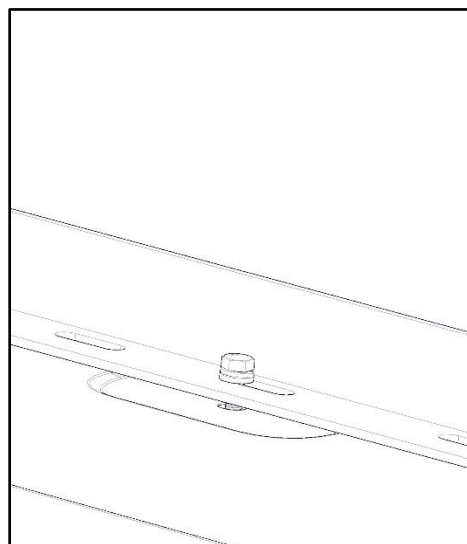

Mid Tighten

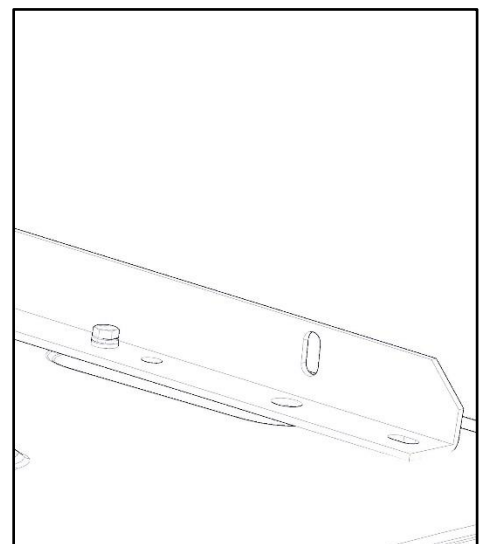

Rear Tighten

DO NOT EXCEED MANUFACTURERS WEIGHT CAPACITY FOR ROOF

NV200/City Express Installation

- Locate 4 mounting locations shown on roof of van.
- Install mounting rail as shown using M8x25mm bolts with lock washers and flat washers.
- In most installs, the rail upright is to the outside of the van.
- Mount rail so there is about 1" from the rear door opening.
- Be sure to put rubber washer between the mounting rail and the roof to ensure sealing.
- Place sealant on and around threads to seal roof. (Passenger side shown)

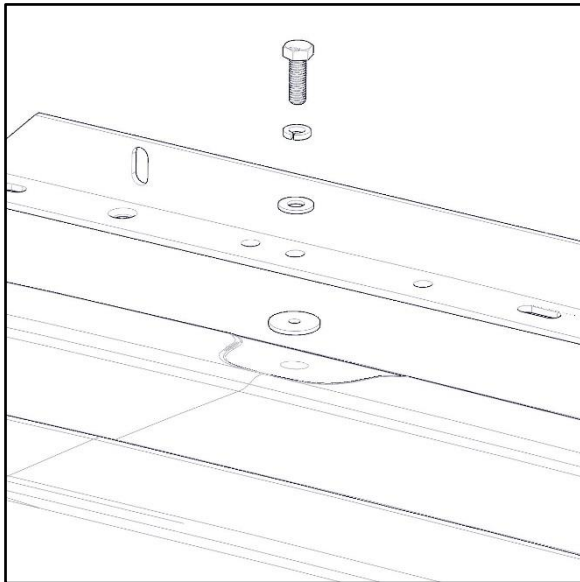
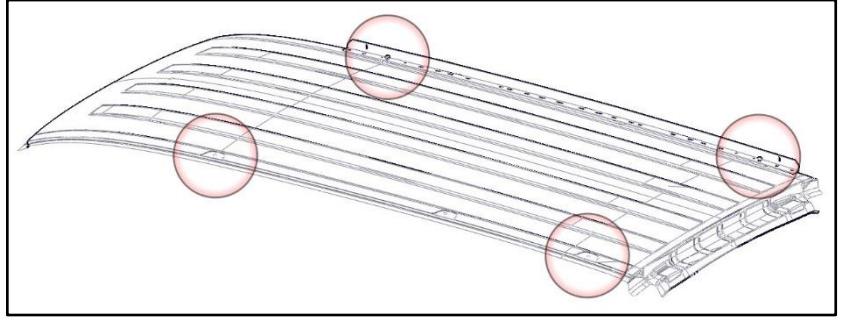

Front EXP

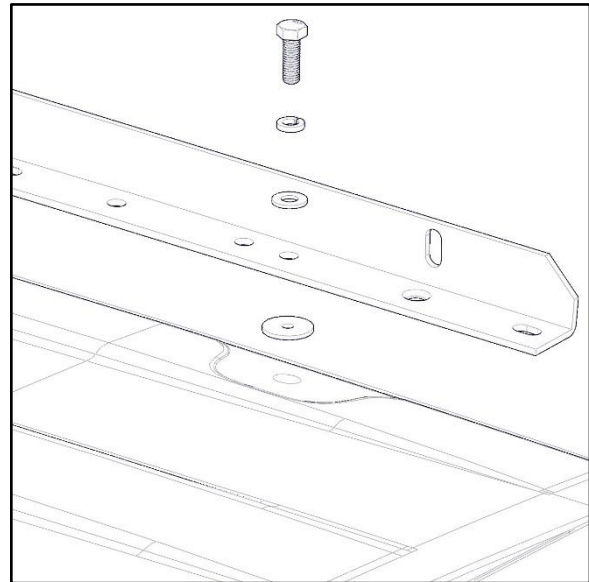

Rear EXP

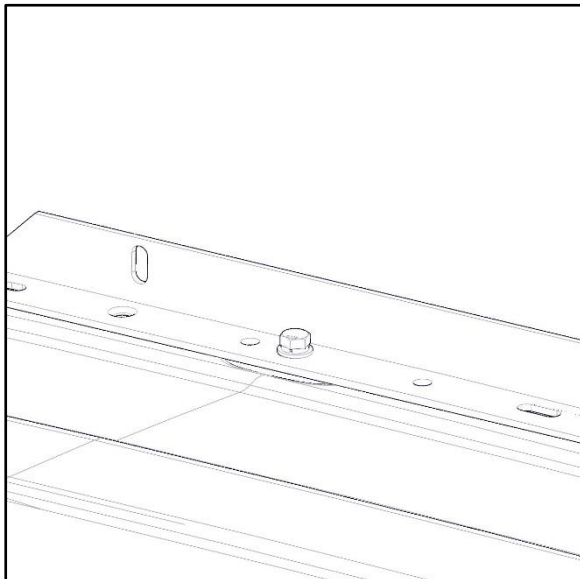

Front Tighten

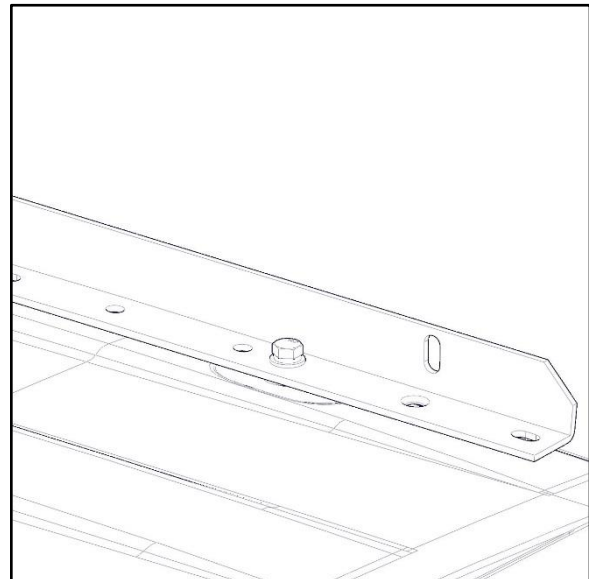

Rear Tighten

DO NOT EXCEED MANUFACTURERS WEIGHT CAPACITY FOR ROOF

Transit Connect Installation

- Locate 4 mounting locations shown on roof of van.
- Be sure to put rubber washer between the mounting rail and the roof to ensure sealing.
- In most installs, the rail upright is to the outside of the van.
- Mount rail so there is about 1" from the rear door opening.
- Install mounting rail as shown using M8x25mm bolts and flat washers on the outside. Use the fender washer and nylock nut on the inside of the van.
- Place sealant on and around threads to seal roof. (Passenger side shown)

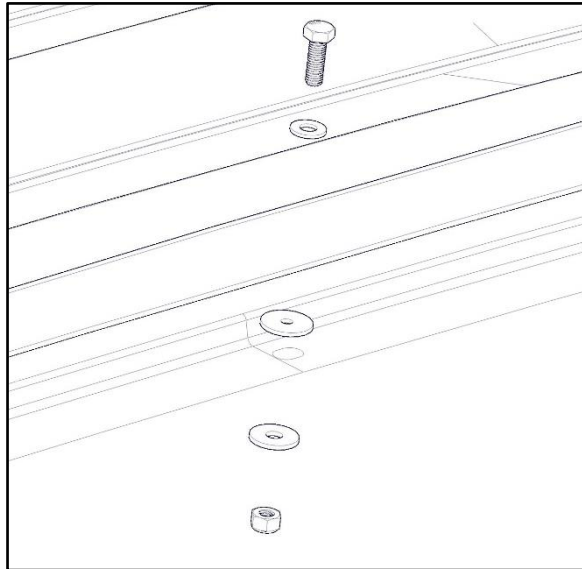
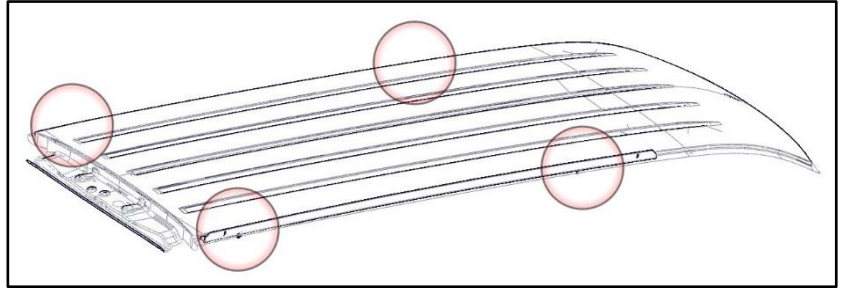

Front EXP

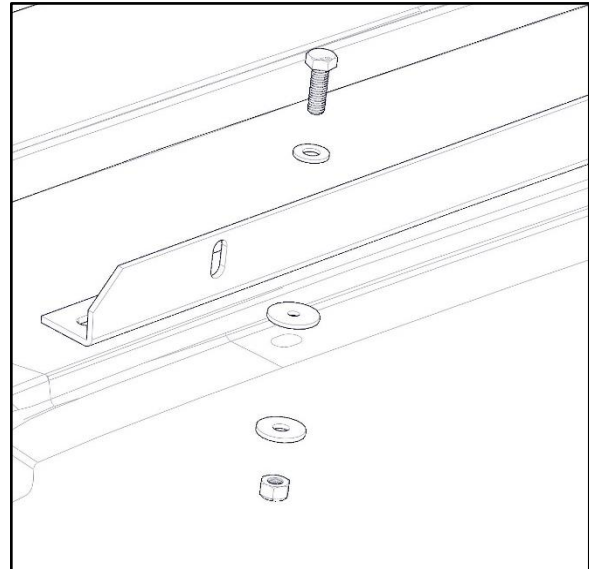

Rear EXP

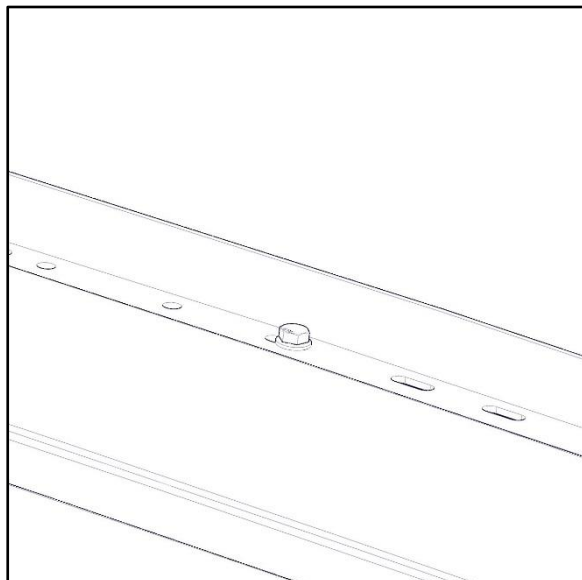

Front Tighten

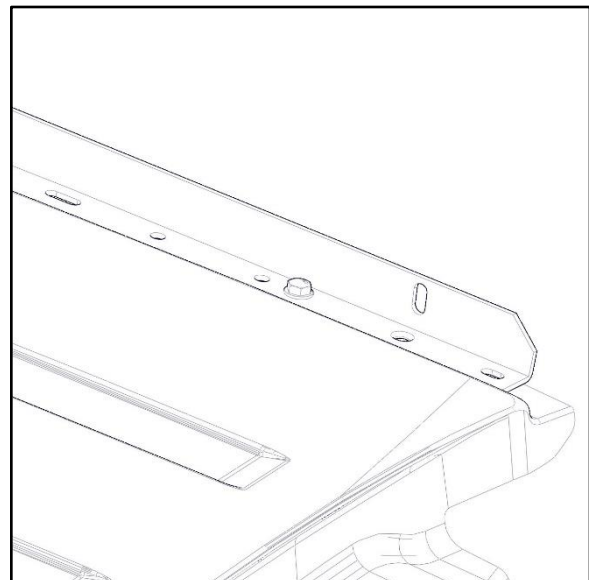

Rear Tighten

Assembly Instructions

Step 1 – Install Foot

- Measure width between previously installed rails.

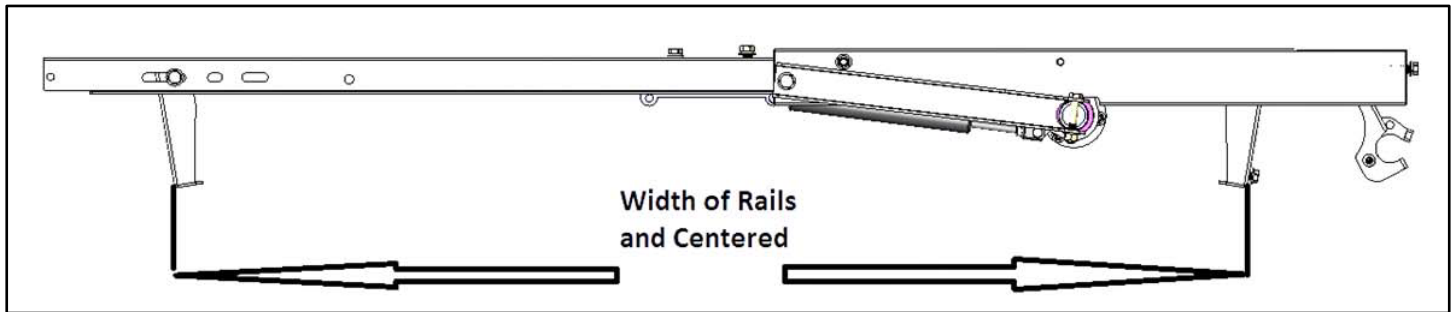

- On the cross bows, use the slots that correspond to the measured distance between rails.
- Use a 3/8" x 3/4" hex head bolt, 3/8" lock washers and a 3/8" flat washer to bolt foot to crossmember.
- Bolt feet to bows as shown, **DO NOT TIGHTEN** at this point.

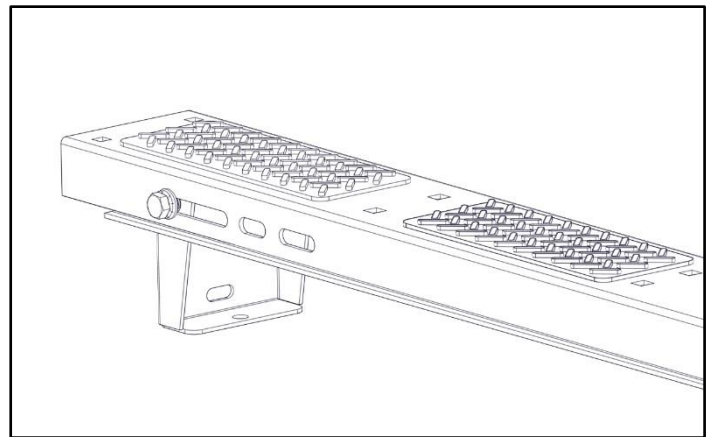
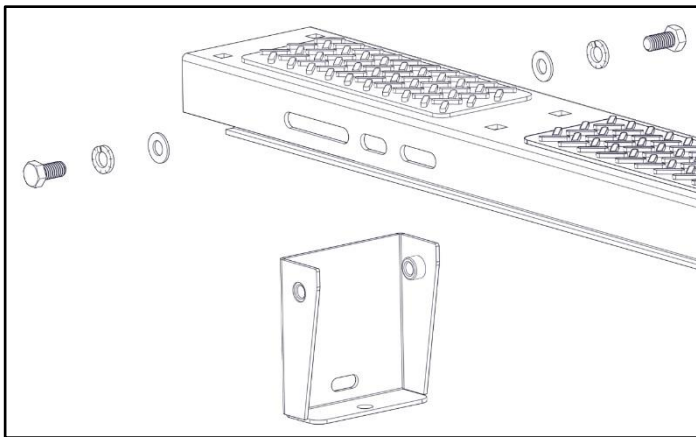

- Feet can be installed as shown above or reverse depending on how you mounted the rail.

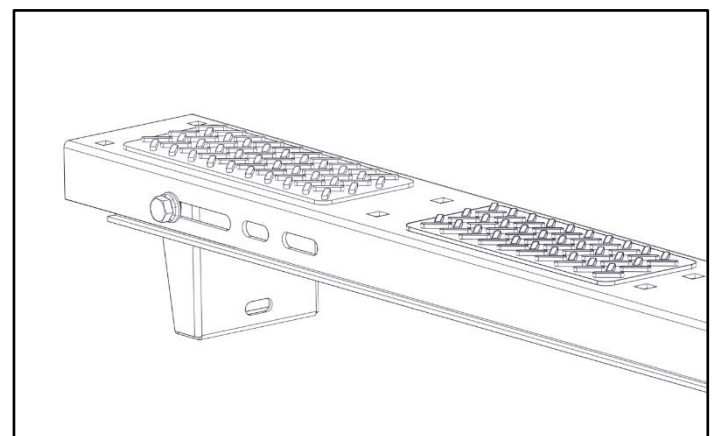
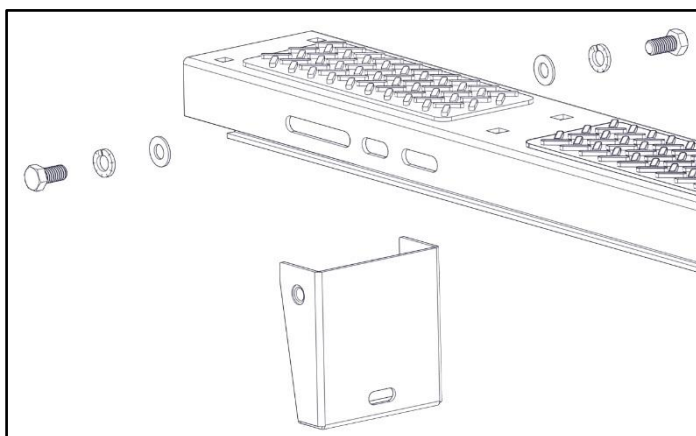

- Snug Tighten, but allow movement.

Step 2 – Ladder Stops

- Bolt ladder stops to one end of each bow.
- Use a 5/16" carriage bolt, 5/16" washers and a 5/16" nyloc.
- TIGHTEN.
- Skip adding the ladder stops if adding 4A81L.

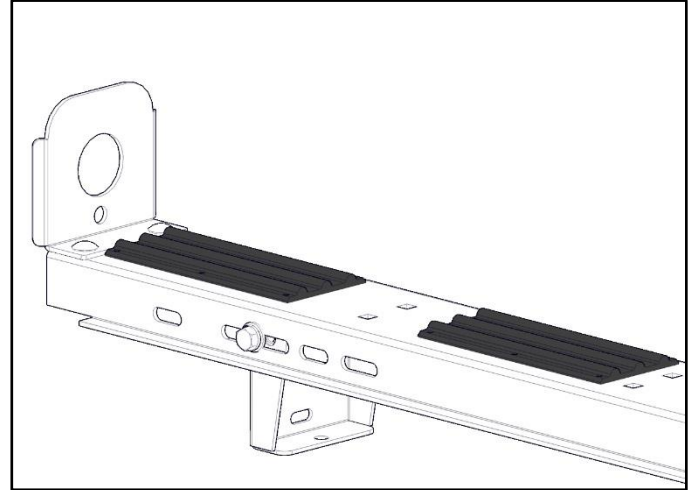
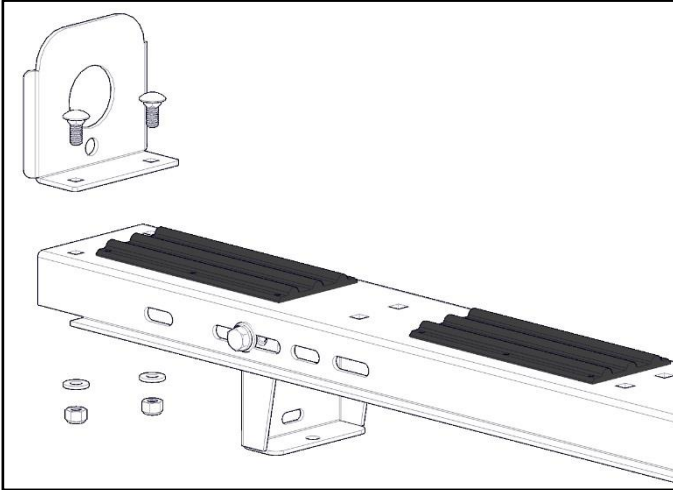

Step 3 – Mount to Rails

- Place both bows on top of installed rails. Bolt feet to rails using 5/16" x 1" HH, two 5/16" flat washers and a 5/16" nyloc nut
- Typically, the ladder hooks go on the driver side of vehicle.
- Snug Tighten, but allow movement.

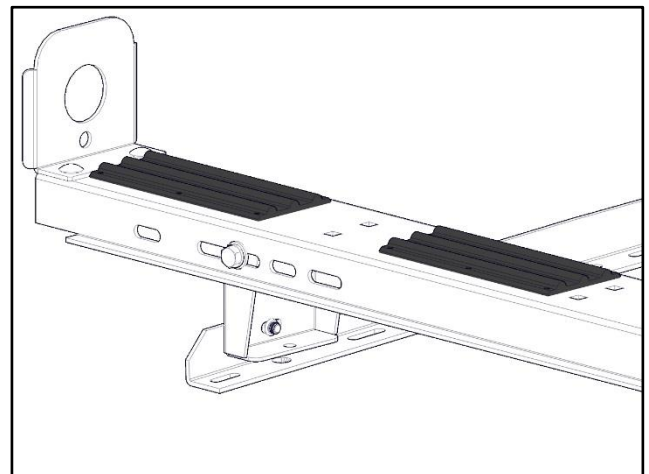
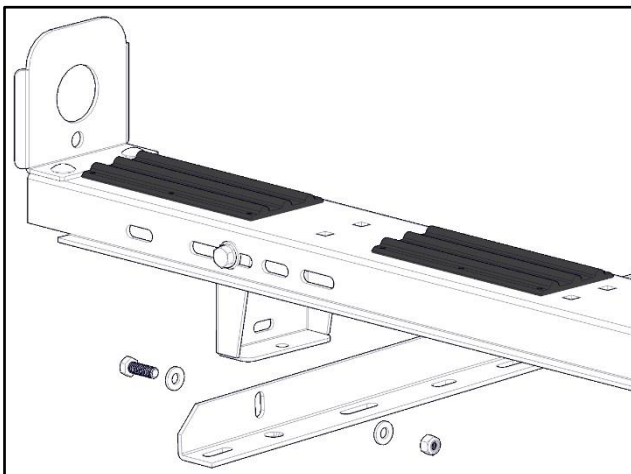
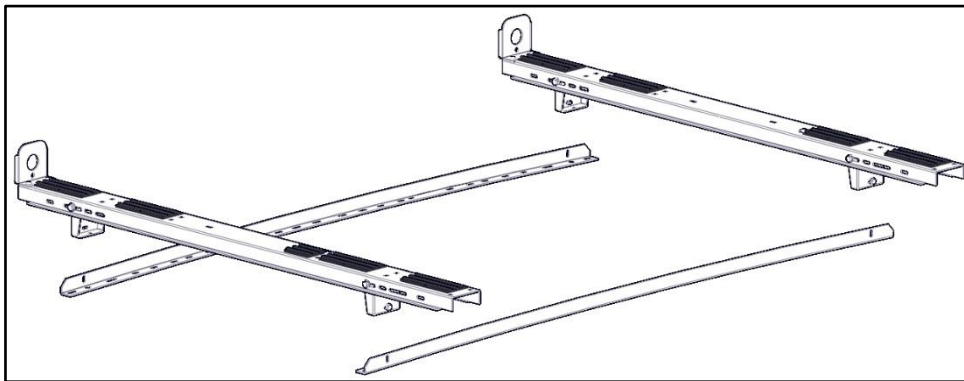

Step 4 – Mount Side Tube

- Assemble side tube. Place sealant around the connection of the two tubes.
- Place side tube assembly on top of installed bows.
- Have the bend towards the front of the vehicle as shown.
- Mount rotation bar plate to the rear of the tube as shown.
- Leave one square slot open at the rear of the side tube.
- Bolt together using 5/16" x 1-3/4" carriage bolt, a 5/16" flat washer and a 5/16" nyloc.
- Snug Tighten, but allow movement.

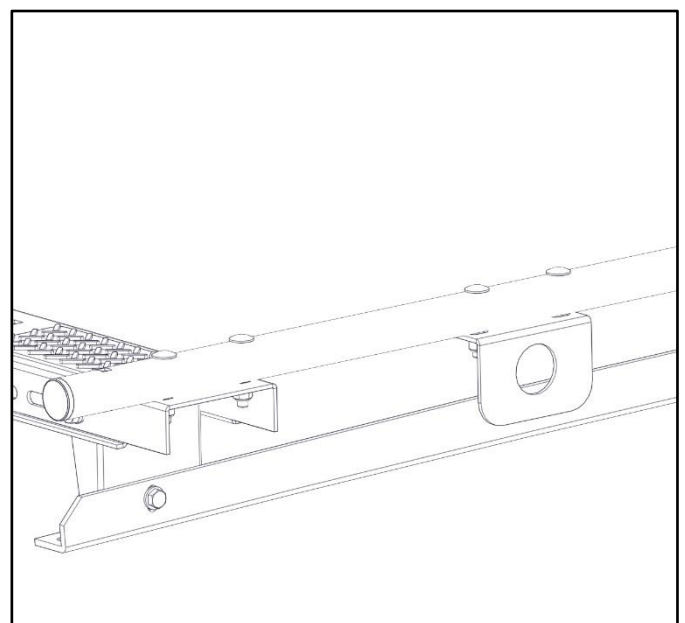
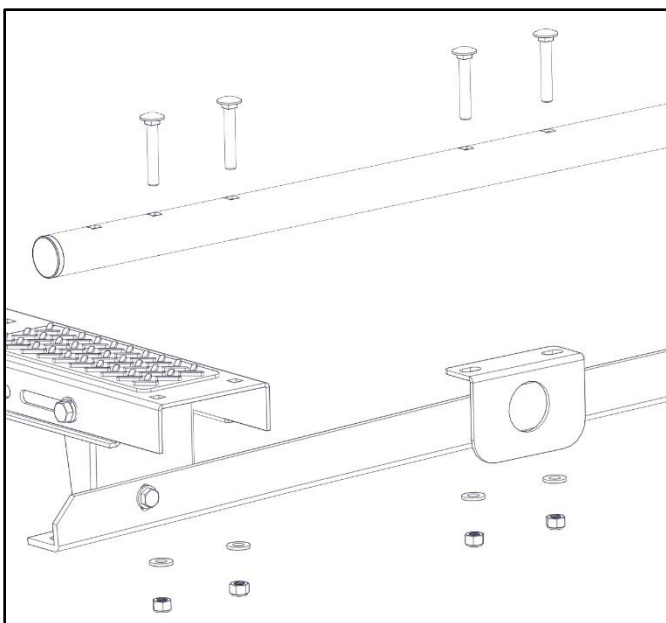
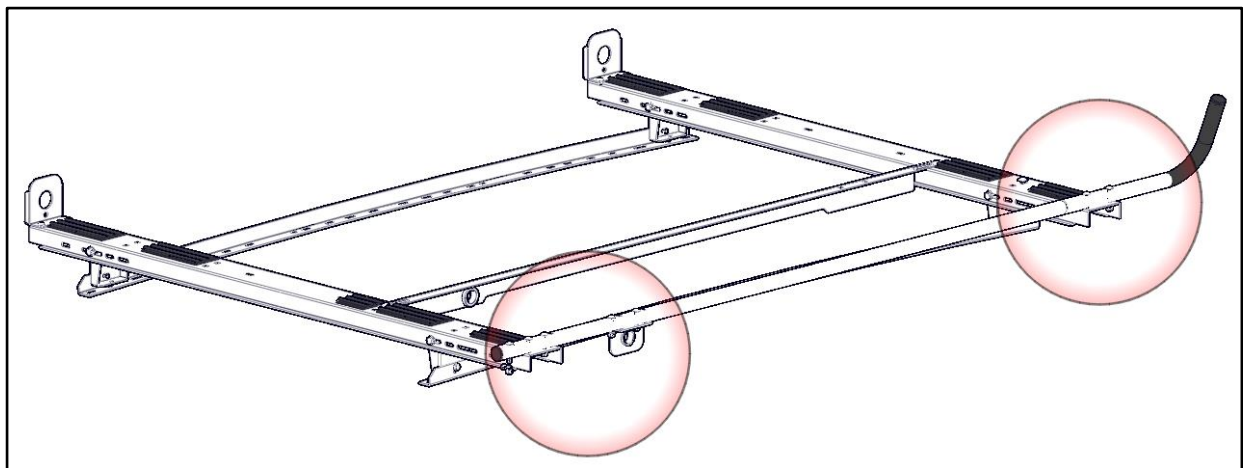
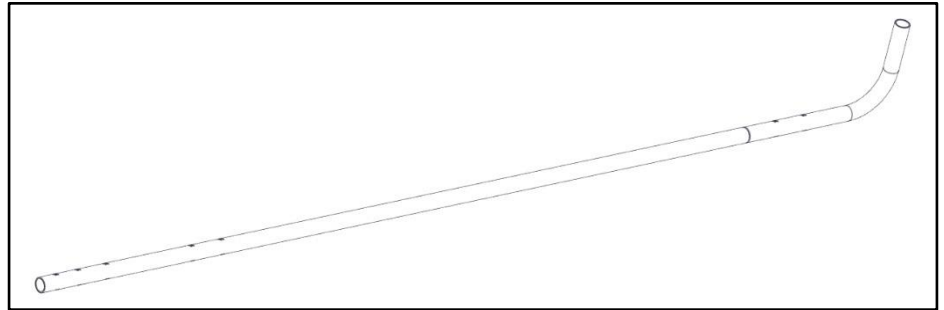
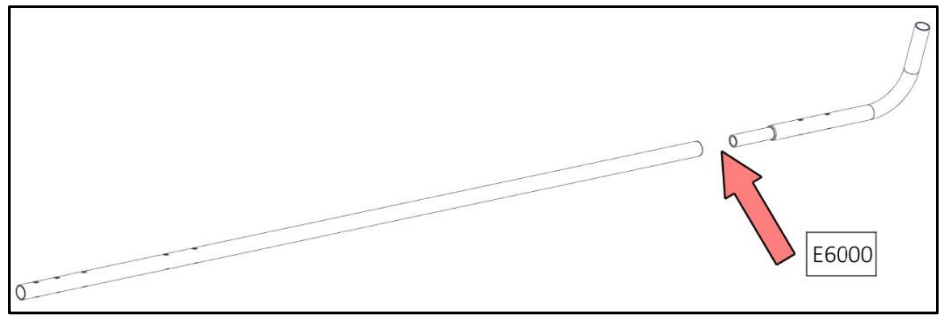

Step 5 – Mount Clamp Tube

- Place clamp and lock L bracket on top of installed bows, do NOT install any hardware.

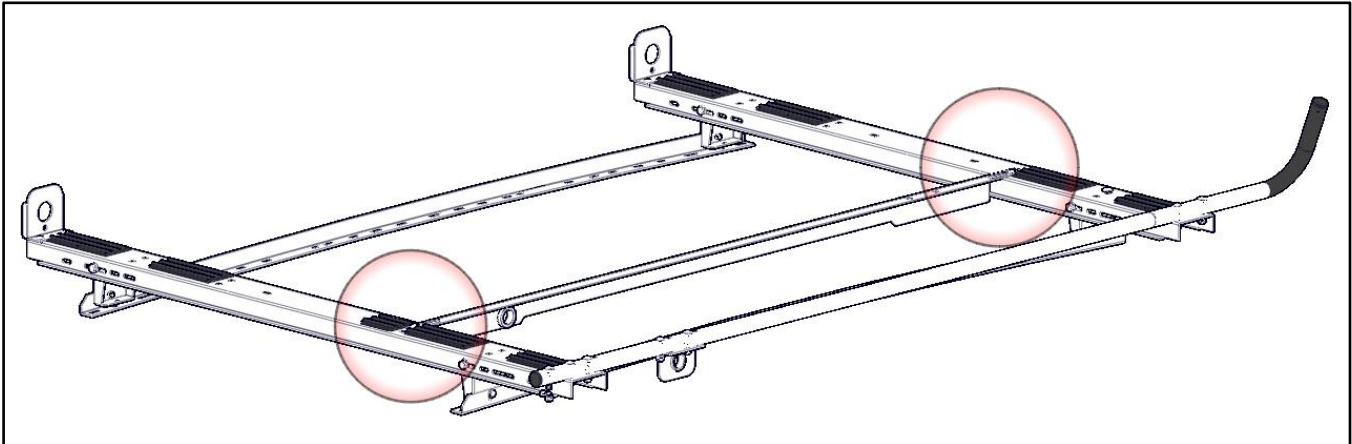

- Insert plastic bushings into the clamp and lock L bracket and the rotation bar plate installed in Step 4, with flanges away from each other and to the inside of the brackets as shown.

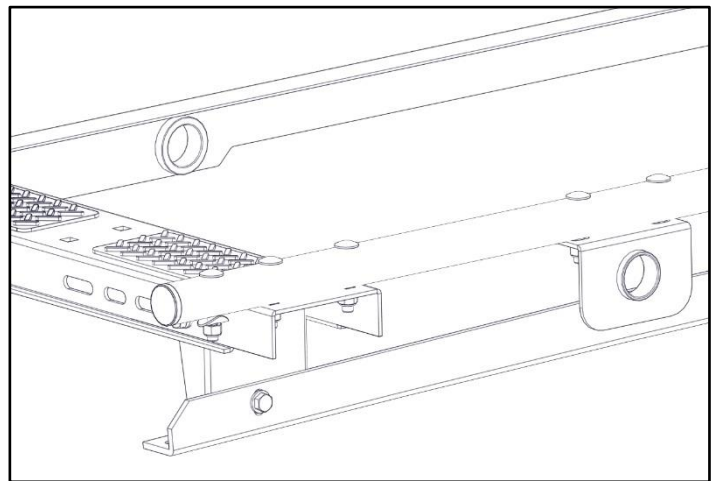
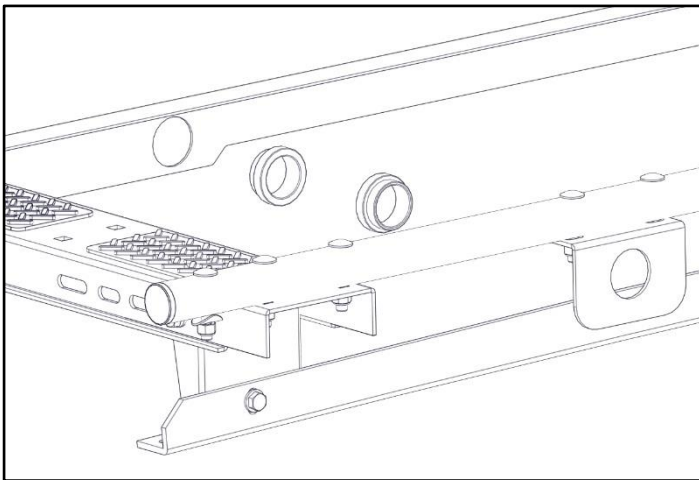

- Insert clamp tube into both plastic bushings.
- After installation, adjust clamp on clamp tube to fit firmly against your ladder.

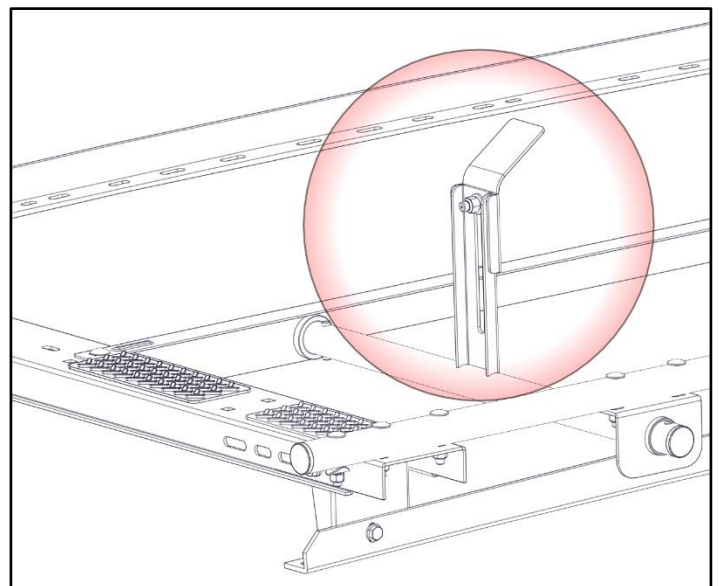
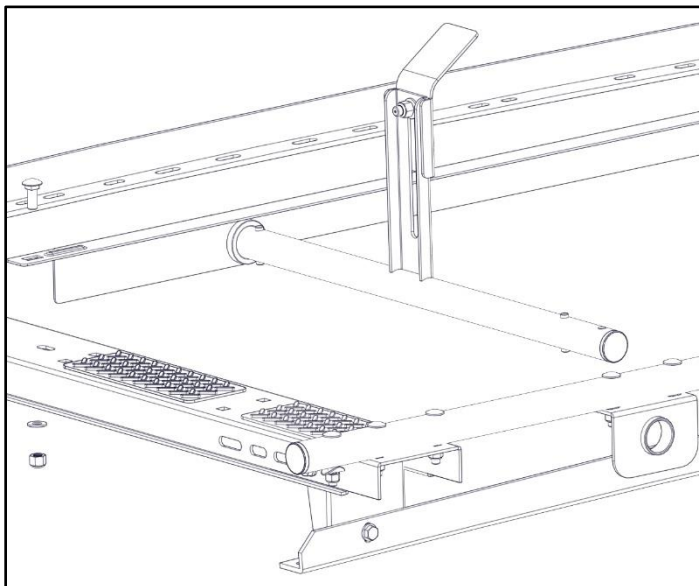

- Bolt clamp and lock L bracket to bows using 3/8" x 1" carriage bolt, 3/8" flat washer and a 3/8" nyloc as shown.
- TIGHTEN

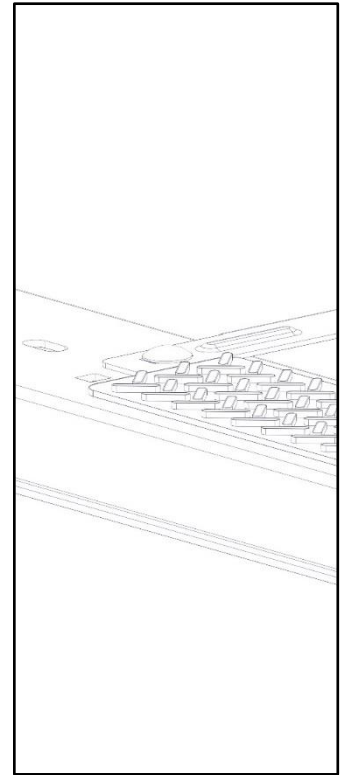
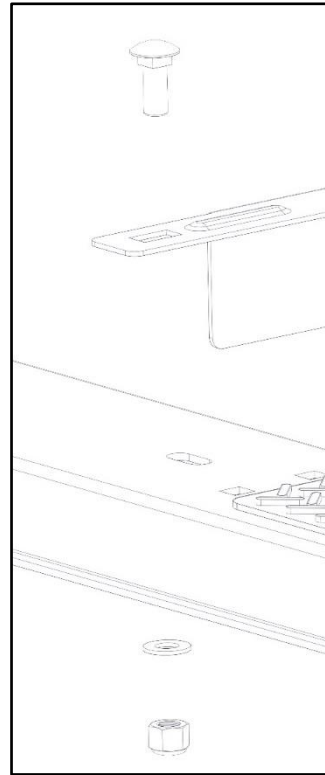
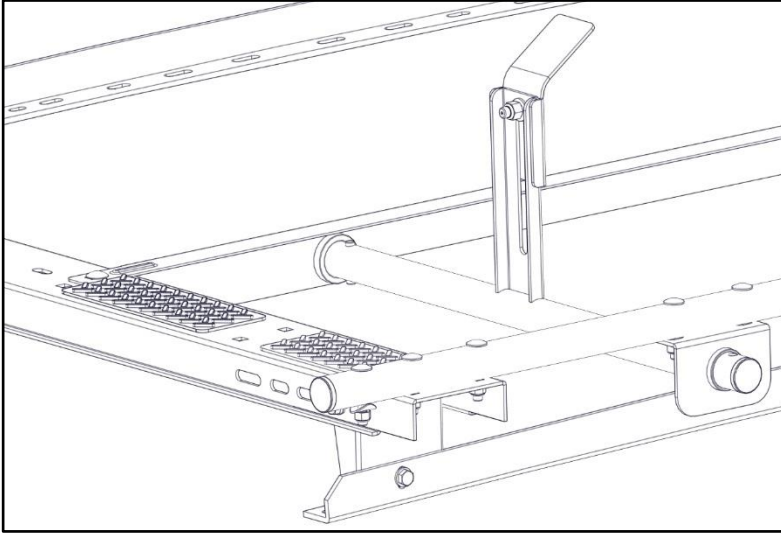

Step 6 – Mount Handle

- Bolt handle to clamp tube using a 5/16" x 2-3/4" hex head, two 5/16" flat washers, 5/16" nylon washer and 5/16" a nyloc. The nylon washer goes in between the clamp tube and handle.
- TIGHTEN

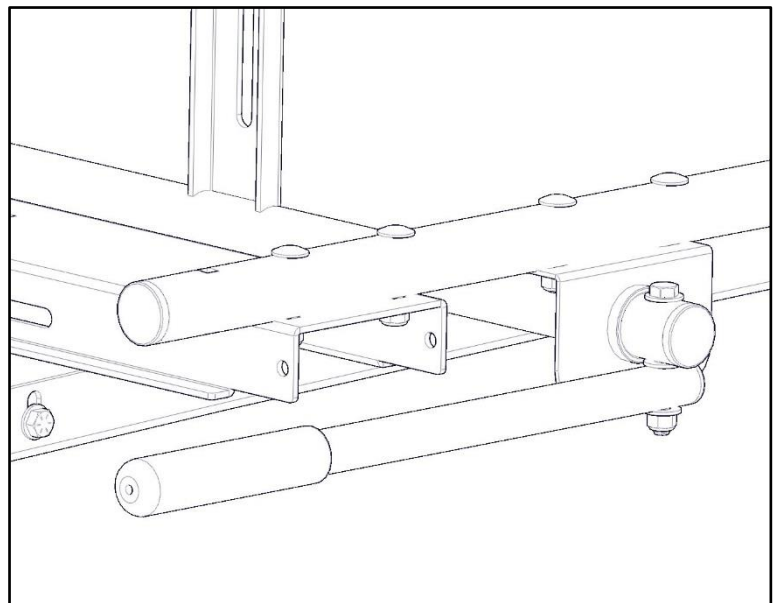
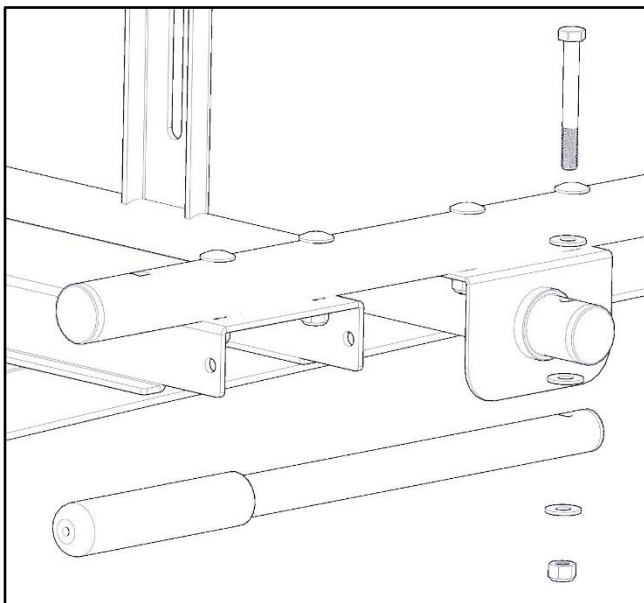

Step 7 – Mount Latch Assembly

- Bolt latch to the rear of the mount tube that was installed in Step 5 using 5/16" x 1-3/4" carriage bolt, 5/16" curved washer and a 5/16" nyloc.
- TIGHTEN

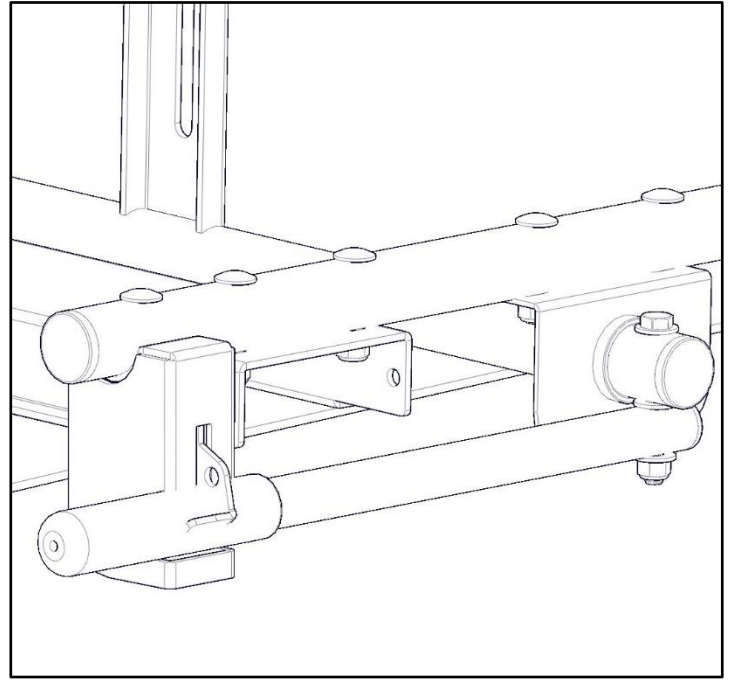
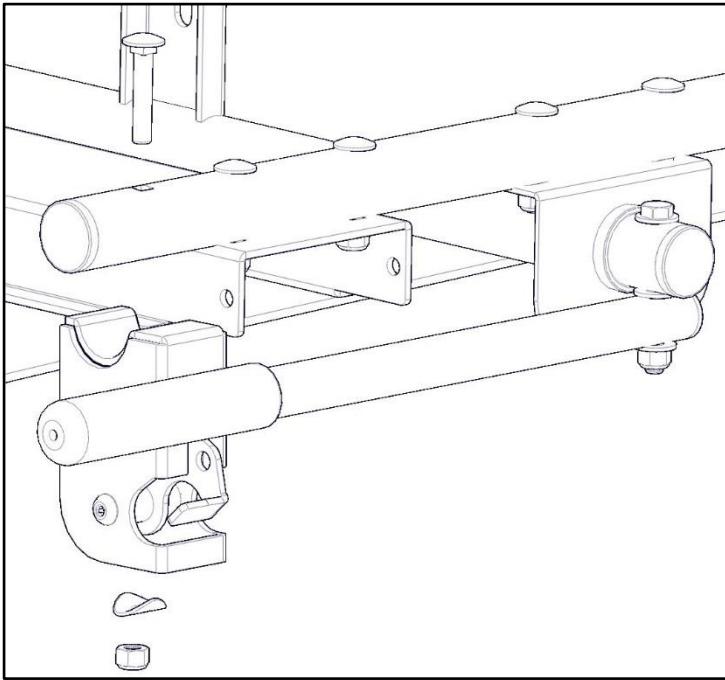

Step 8 – Mount Ladder Hook Bracket to Bow

- Bolt ladder hook bracket to the bow in the orientation shown using a 3/8" x 1" carriage bolt, a 3/8" flat washer and a 3/8" nyloc. Be sure the bracket is square to the bow.
- Adjust clamp on bracket to fit firmly against your ladder.
- TIGHTEN

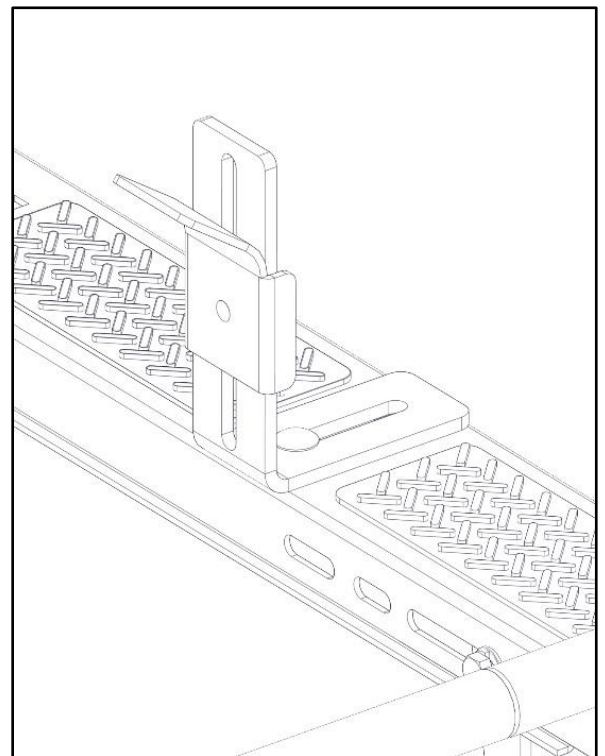
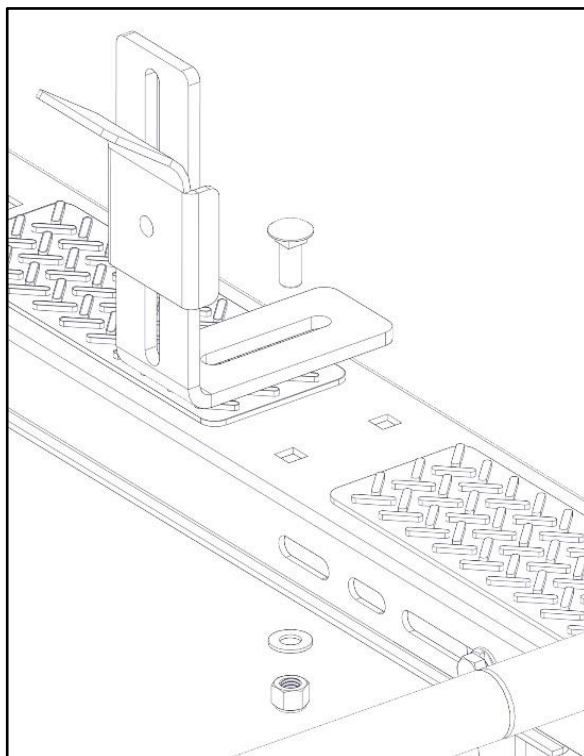

Step 9 – Place Rubber Bumper

- Adjust clamp on bracket to fit firmly against your ladder.
- If ladder rests on cross bow, place extra rubber bumper to avoid scratching.

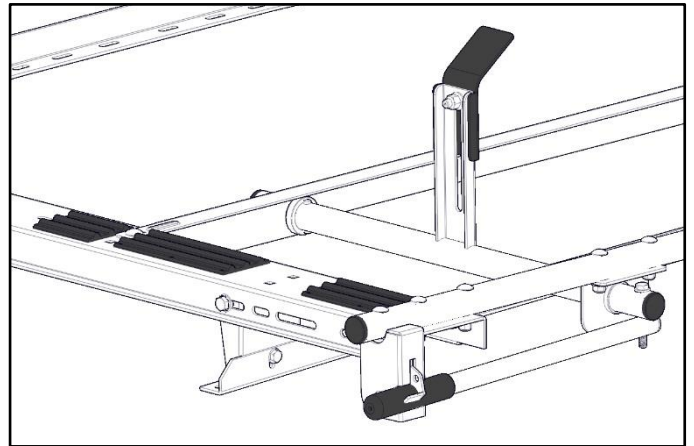
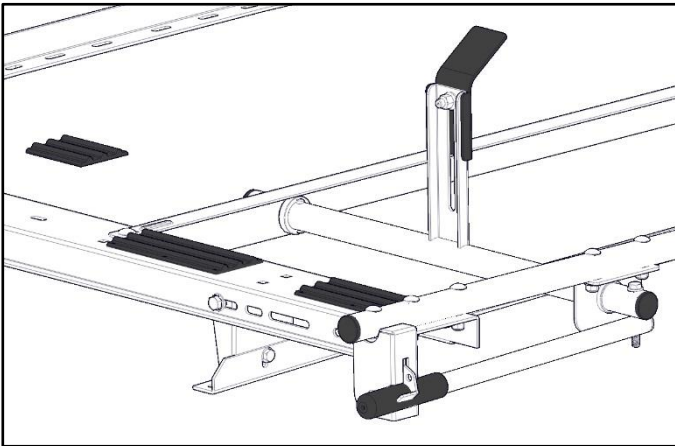
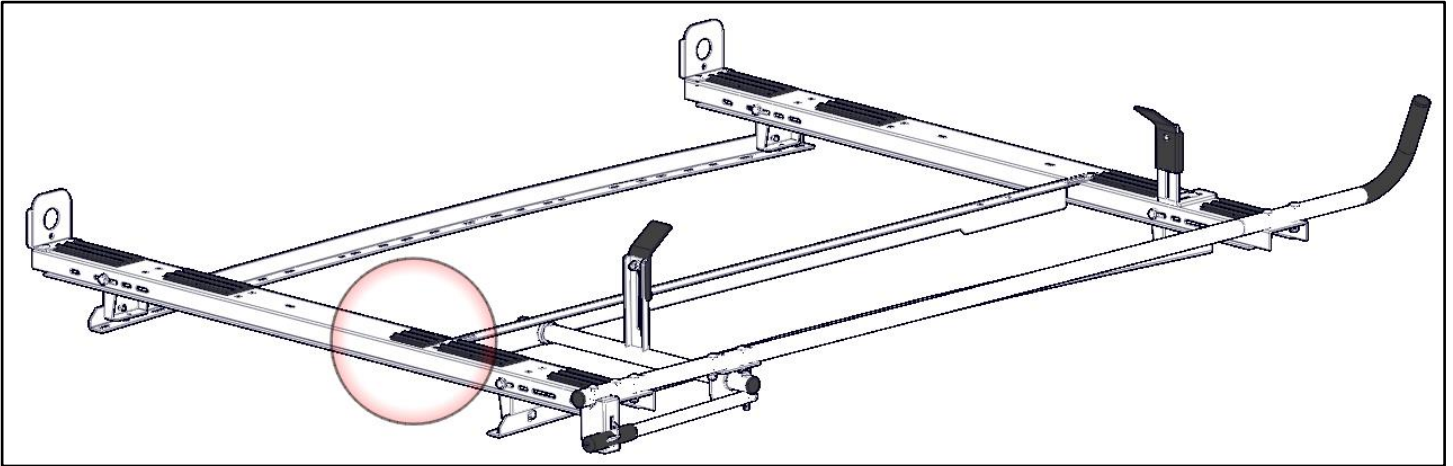

GO BACK AND ENSURE ALL HARDWARE IS TIGHT
Your installation is now complete.

KARGO MASTER®

WE PUT EVERYTHING WITHIN REACH.

Instruction Guide

4A81L

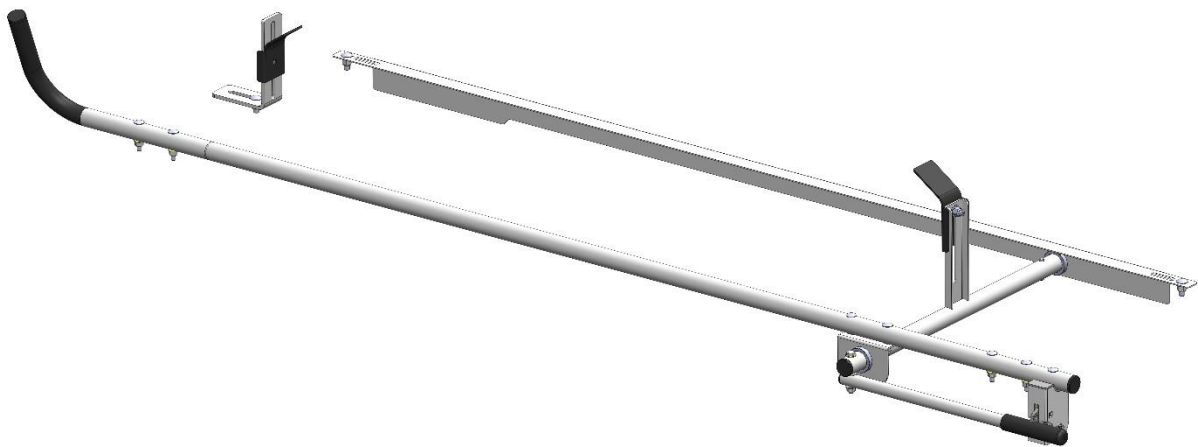

***PLEASE READ ALL INSTRUCTIONS AND WARNINGS PRIOR TO ASSEMBLING,
INSTALLING, AND USING THIS PRODUCT***

Warning



Always check for wires, fuel tanks and lines, brake lines and other important vehicle functionality items prior to drilling and installing all products.





Tools Needed

9/16" Socket and Wrench	1/2" Socket and Wrench
-------------------------	------------------------

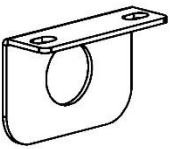
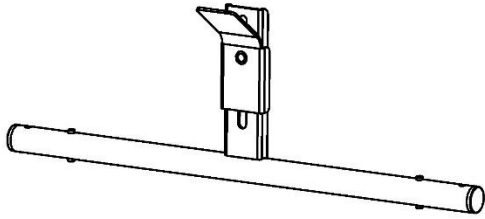
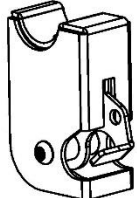

Before You Begin

- Read all instructions.
 - **DO NOT EXCEED MANUFACTURERS WEIGHT CAPACITY FOR ROOF.**
 - This kit is the Driver Side add on ONLY.
 - **BE SURE TO ADJUST LADDER CLAMPS ACCORDINGLY TO FIRMLY SECURE LADDER TO RACK.**
-

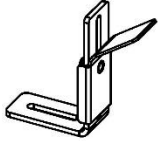
Parts

ITEM NO.		PART NUMBER	DESCRIPTION	QTY.
A		4A800-00-003-R3-L	Clamp and Lock L Bracket	1
B		4A800-50-001-R3	Side Tube	1
C		4A800-50-002-R2-L	Side Hook	1
D		11-03027A	Angle BRK	1
E		4A800-30	Clamp Tube	1
F		4A800-20	Latch Assy.	1
G		4A800-40	Handle	1
H		4A800-60	Ladder Stop Assembly	1
		18-4A81L	Hardware	1

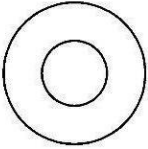
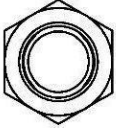
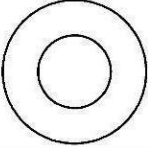
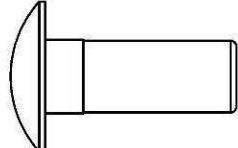
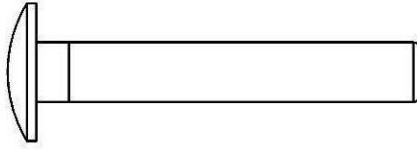
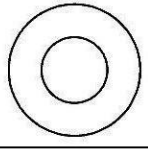
Assembly Hardware (18-4A81L)

ITEM NO.	TO SCALE	PART NUMBER	DESCRIPTION	QTY.
1		90295A160	.06x.34x.75 Nylon Washer	1
2		.375-16 NYLOC	3/8-16 Nyloc Nut	3
3		.375 FLAT WASHER	3/8 Flat Washer	3
4		.375-16 x 1 Carriage	3/8-16x1 Carriage Bolt	3
5		.312-18x2.0 CARRIAGE BOLT	5/16-18x2.0 Carriage Bolt	7
6		96659A107	5/16 FLAT WASHER	8
7		91831A030	5/16 NYLOC	8

Assembly Hardware (18-4A81L) Continued

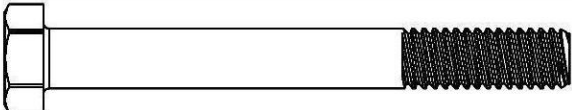
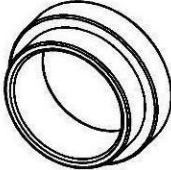
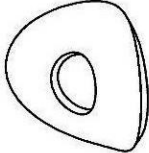
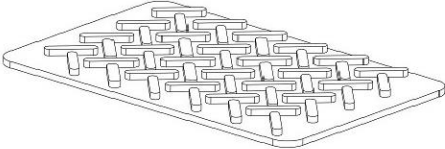
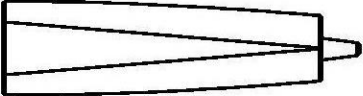
8		.312-18 X 2.75 HEX BOLT	5/16-18x2 3/4 Hex Bolt	1
9		40800-10-007	PLASTIC BUSHING 1:2 SCALE	2
10		91844A230	5/16 CONTOUR WASHER	1
11		Extra Rubber Pad	1:2 SCALE	1
		BH-821	Sealant	1

Step 1 – Remove Ladder Stops

- If havent already done so, remove ladder stops from opposite end of both bows where the clamp and lock is installed.

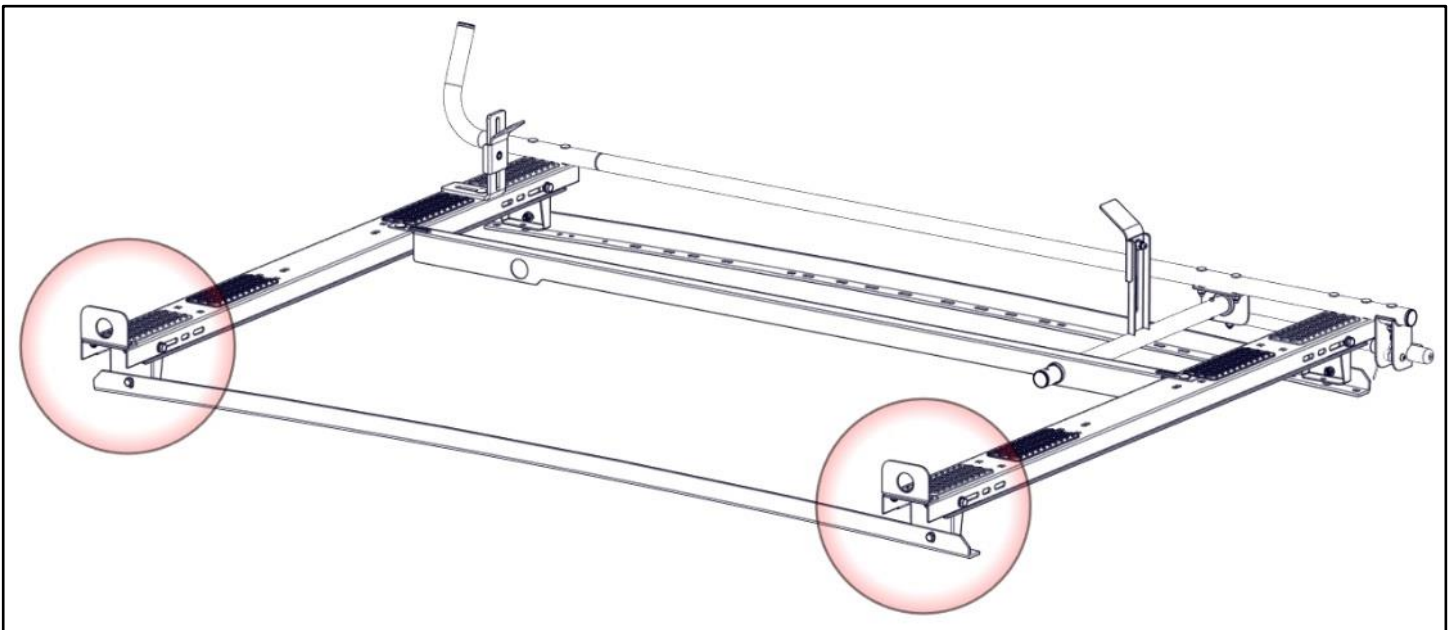
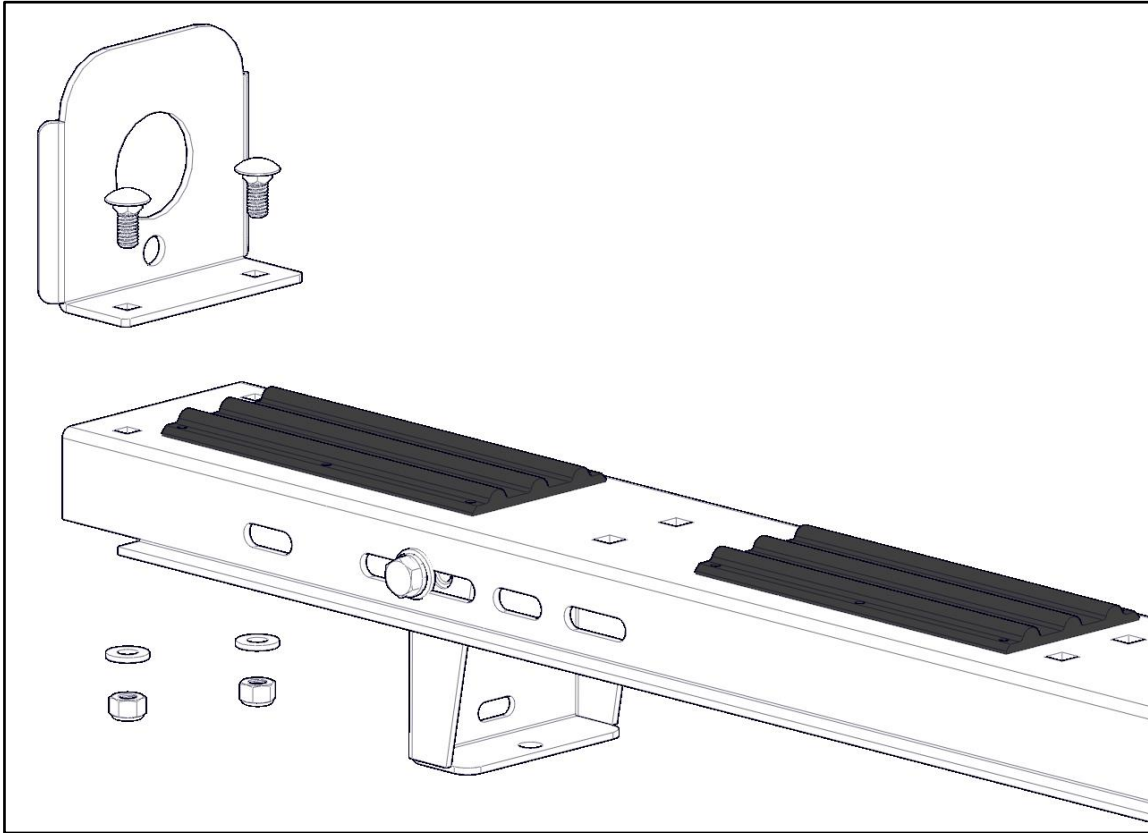

Step 2 – Mount Side Tube

- Place a generous amount of sealant into the tube connection.
- Place side tube on top of installed bows.
- Have the bend towards the front of the vehicle as shown.
- Mount rotation bar plate to the rear of the tube as shown.
- Leave one square slot open at the rear.
- Bolt together using 5/16" x 2" carriage bolt, a 5/16" flat washer and a 5/16" nyloc.
- Snug Tighten, but allow movement.

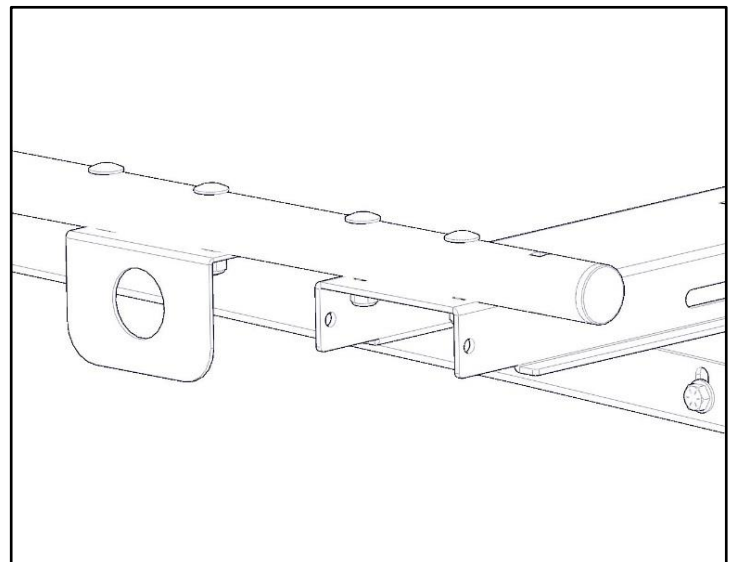
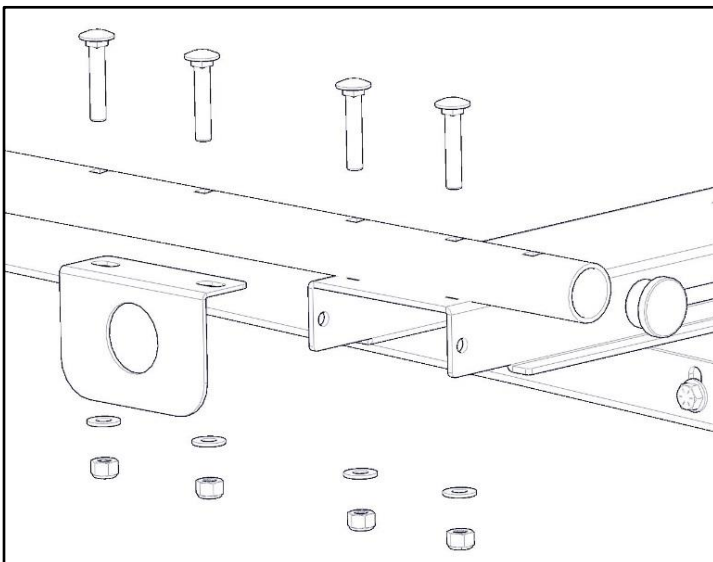
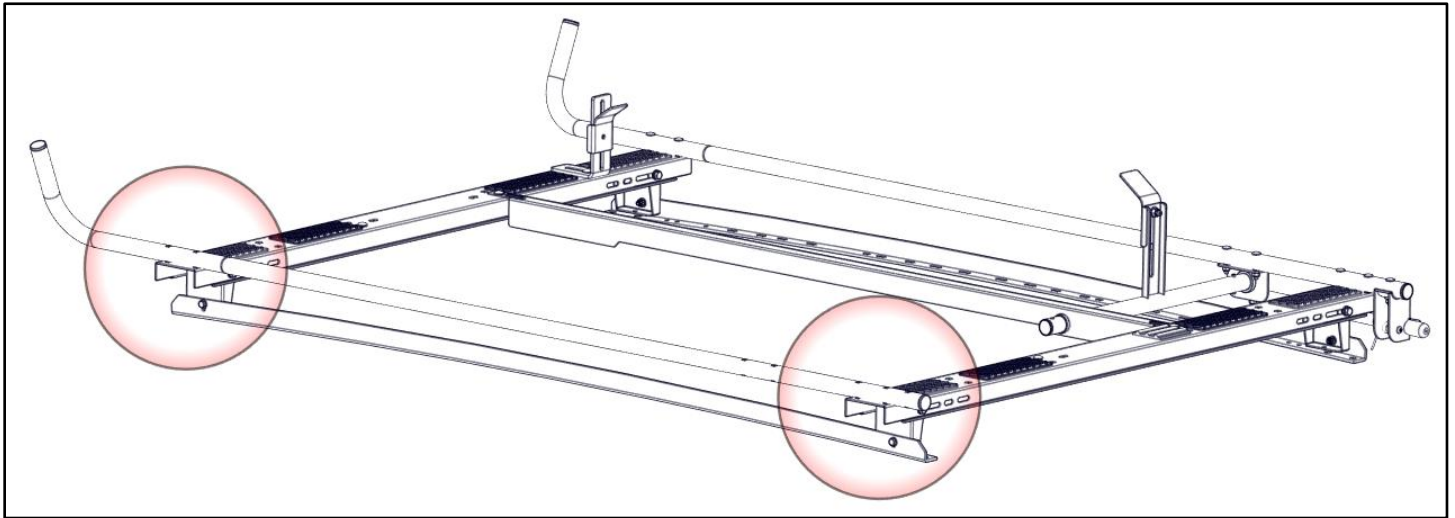
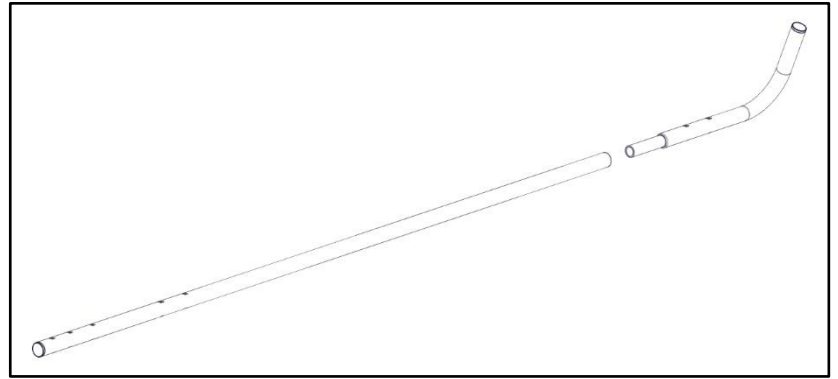

Step 3 – Mount Clamp Tube

- Place clamp and lock L bracket on top of installed bows. Do not install hardware right now.
- Insert plastic bushings into the clamp and lock L bracket and the rotation bar plate installed in Step 2, with flanges as shown so they cannot come out at a later time. If bushings are not placed in correct orientation, they can fall out.

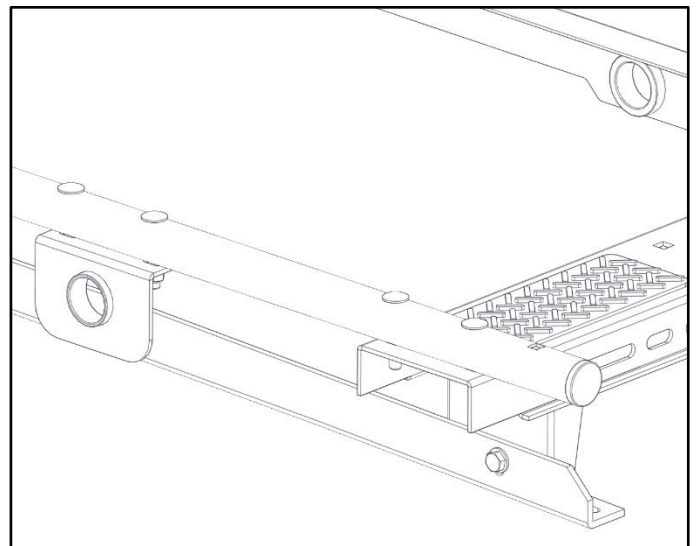
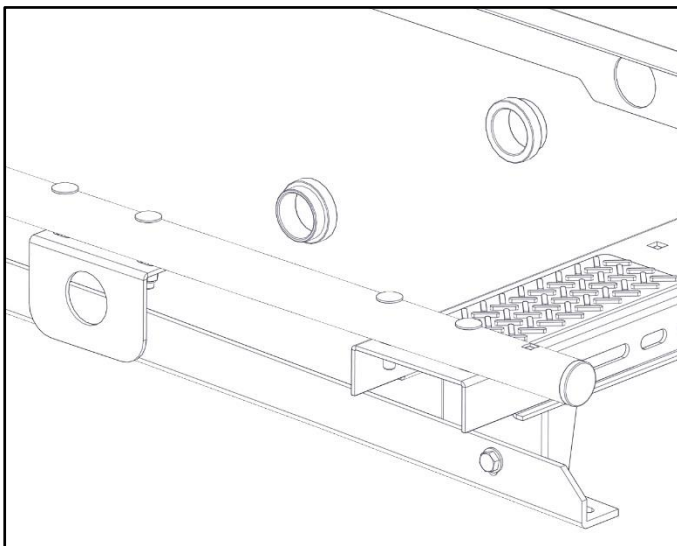
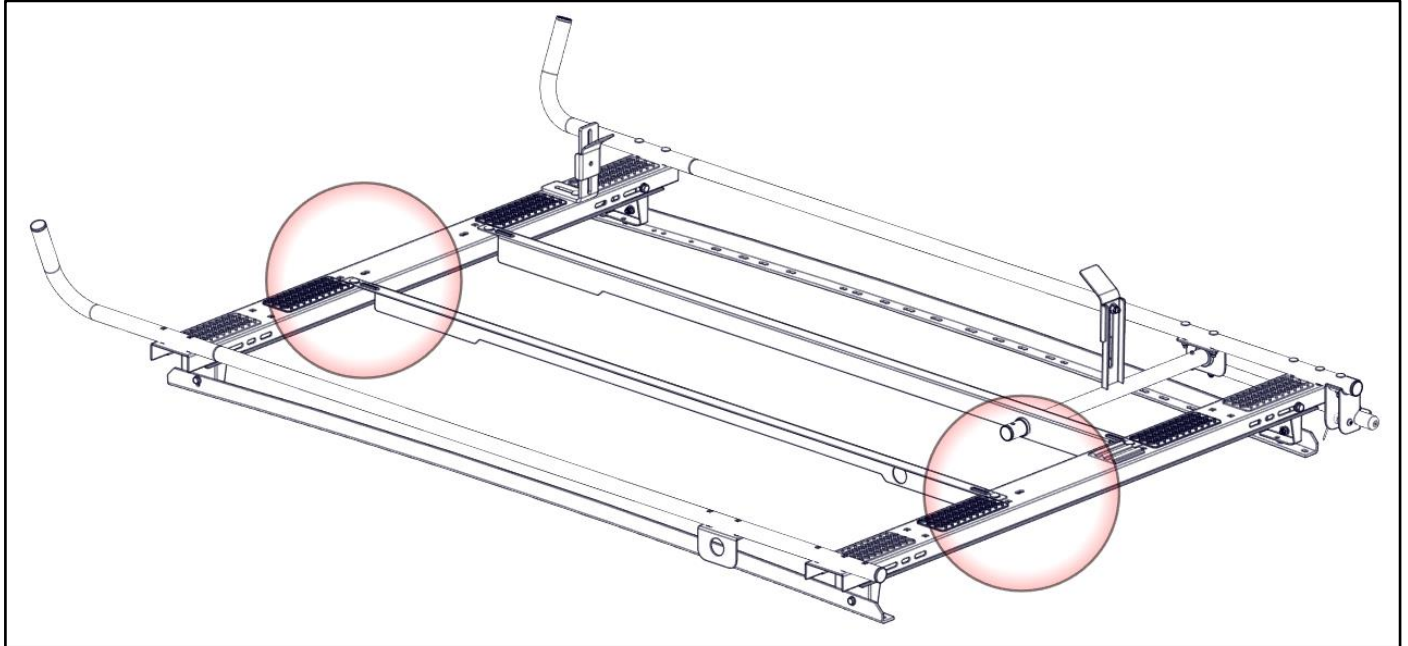

- Insert clamp tube into both plastic bushings.
- Adjust clamp on clamp tube to fit firmly against your ladder.

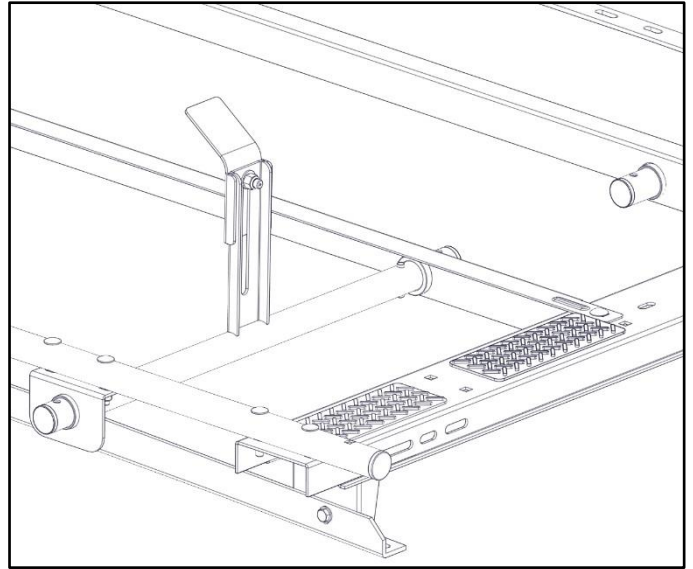
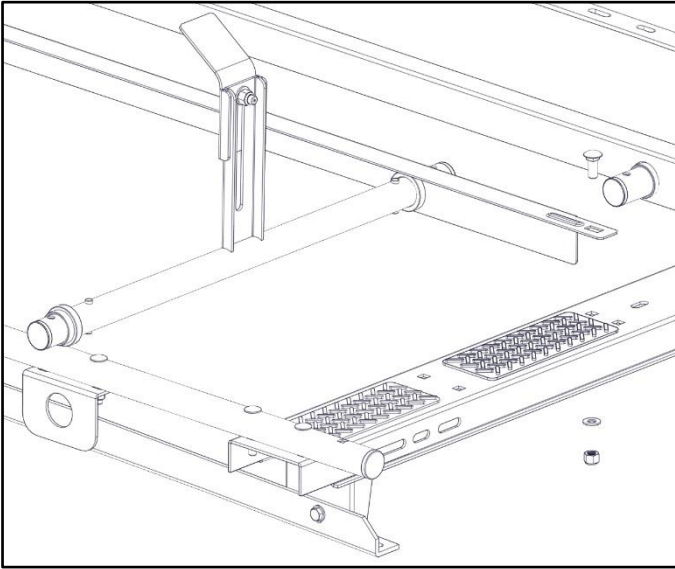

- Bolt clamp and lock L bracket to bows using 3/8" x 1" carriage bolt, 3/8" flat washer and a 3/8" nyloc as shown.
- TIGHTEN

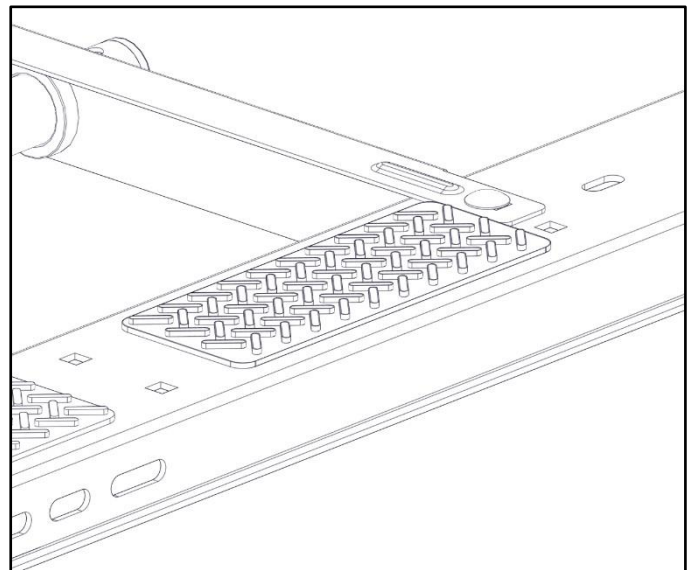
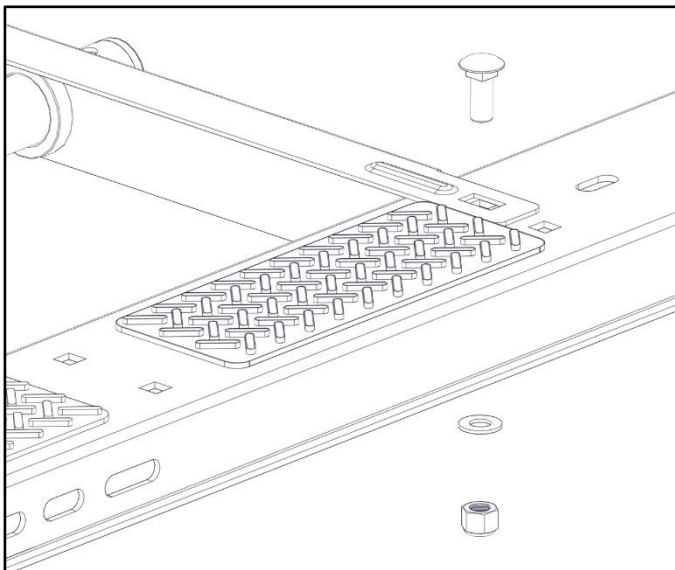

Step 4 – Mount Handle

- Bolt handle to clamp tube using a 5/16" x 2-3/4" hex head, two 5/16" flat washers, 5/16" nylon washer and 5/16" a nyloc. The nylon washer goes in between the clamp tube and handle.
- TIGHTEN

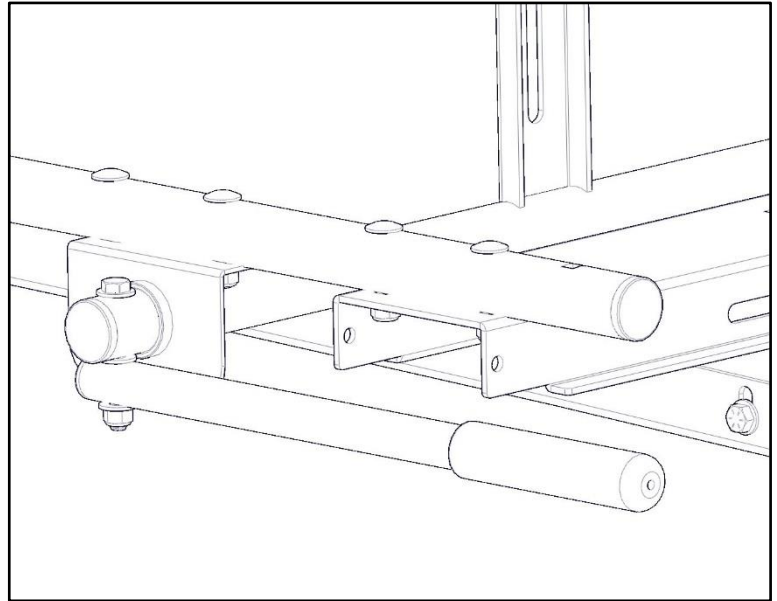
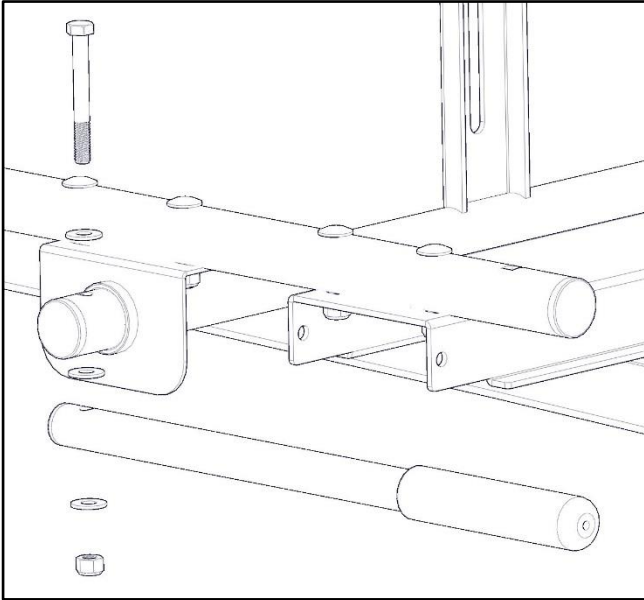

Step 5 – Mount Latch Assembly

- Bolt latch to the rear of the mount tube that was installed in Step 5 using 5/16" x 2" carriage bolt, 5/16" curved washer and a 5/16" nyloc.
- TIGHTEN

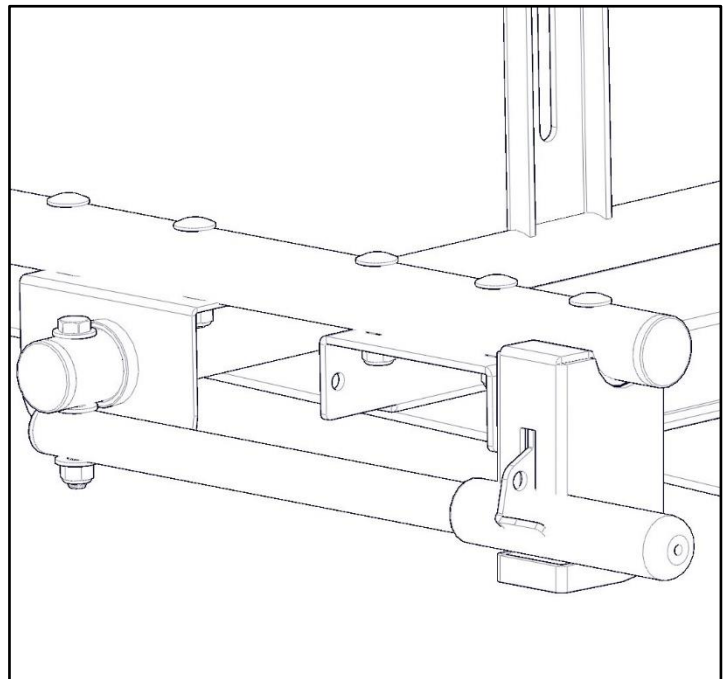
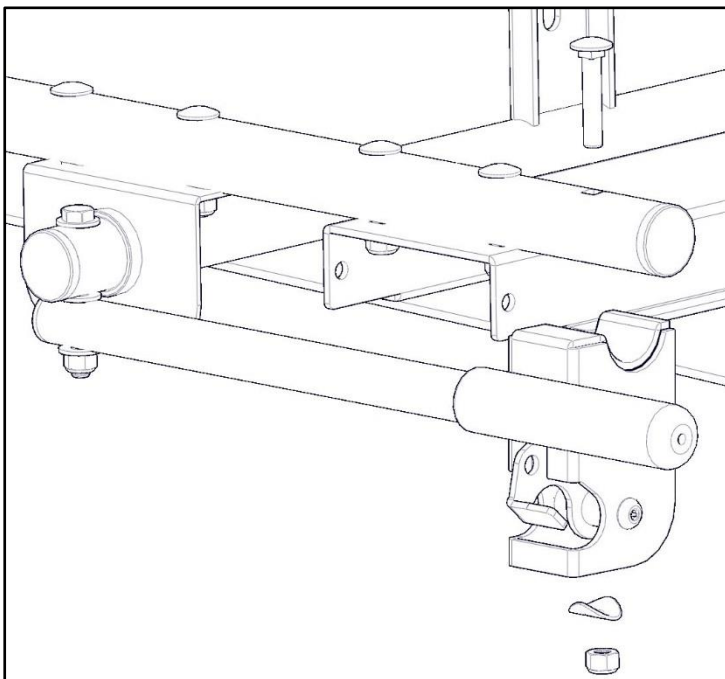

Step 6 – Mount Ladder Hook

- Bolt ladder hook bracket to the bow in the orientation shown using a 3/8" x 1" carriage bolt, a 3/8" flat washer and a 3/8" nyloc. Be sure the bracket is square to the bow.
- Adjust clamp on bracket to fit firmly against your ladder.
- TIGHTEN

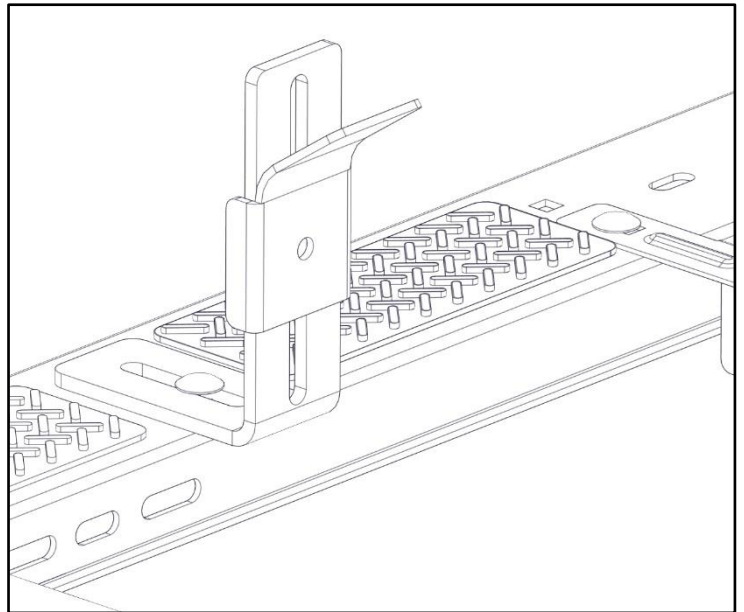
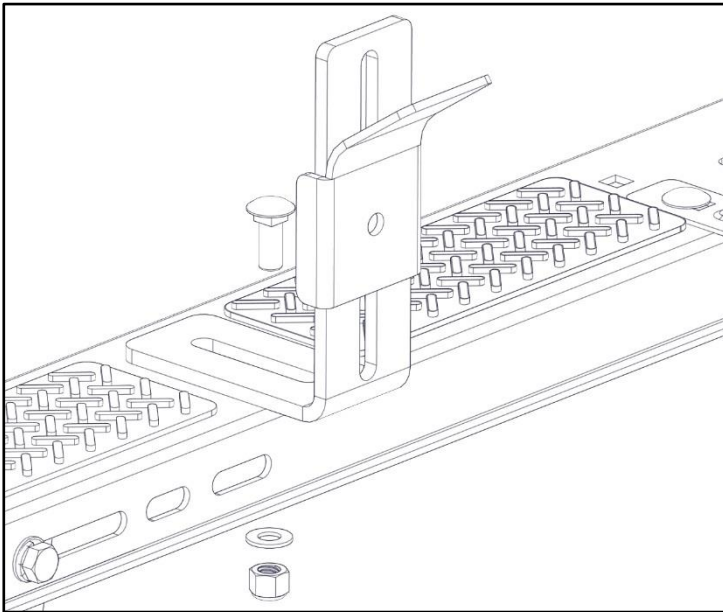

Step 7 – Install Extra Pad

- Adjust clamp on bracket to fit firmly against your ladder.
- If ladder rests on cross bow, place extra rubber bumper to avoid scratching.

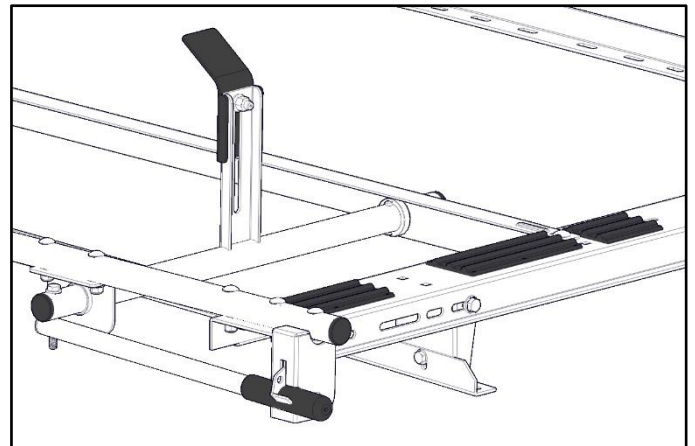
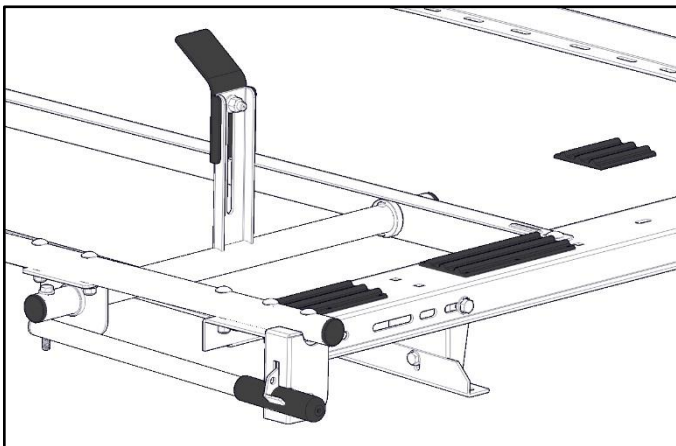

GO BACK AND ENSURE ALL HARDWARE IS TIGHT
Your installation is now complete.

BE SURE LADDER IS SECURE PRIOR TO TRANSPORTATION

