

KARGO MASTER[®]

WE PUT EVERYTHING WITHIN REACH.

Installation Guide

4089T

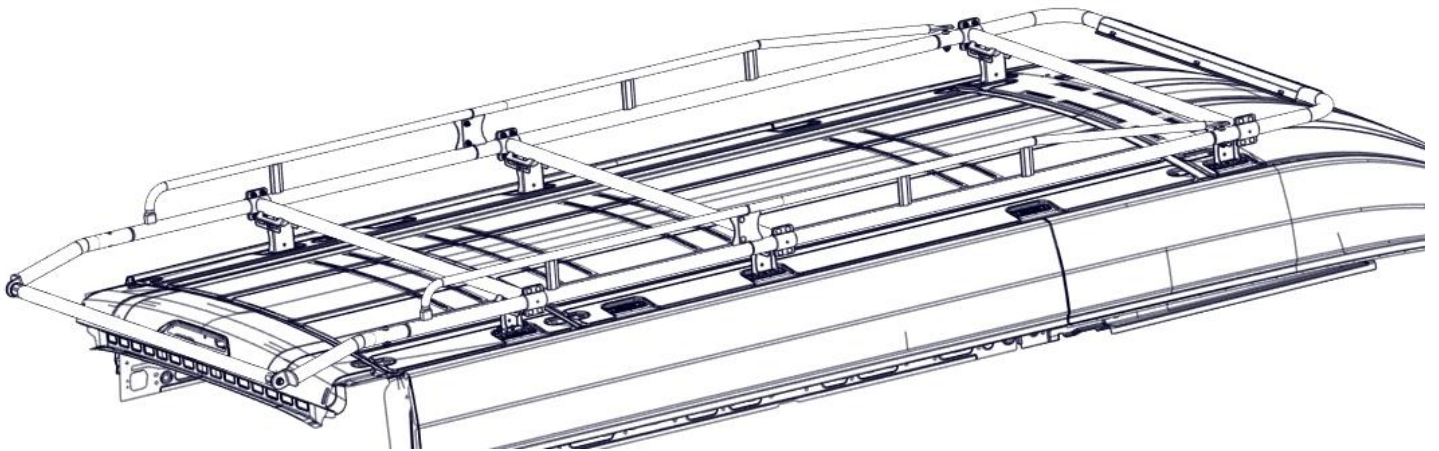

***PLEASE READ ALL INSTRUCTIONS AND WARNINGS PRIOR TO ASSEMBLING,
INSTALLING, AND USING THIS PRODUCT***

Warning



Always check for wires, fuel tanks and lines, brake lines and other important vehicle functionality items prior to drilling and installing all products.

Tools Needed

9/16" Wrench and Socket	13mm Wrench and Socket
Tape Measure	

Before You Begin

- There are different instructions for different vehicles. USE PROPER INSTALLATION.
- Follow the instructions included in the ladder rack to assemble the ladder rack.
- If installing on Ford Transit or a Sprinter, be sure to put E6000 around exposed holes in the roof. Place E6000 between the roof and the rubber pads.
- Some adjustment is going to be needed on the ladder rack itself to coordinate with the mount locations on the roof of the van. Use the dimensions measured from the roof mount locations and coordinate onto the rack crossbars (X & Y). Some slight adjustment will be needed once rack is placed onto roof.

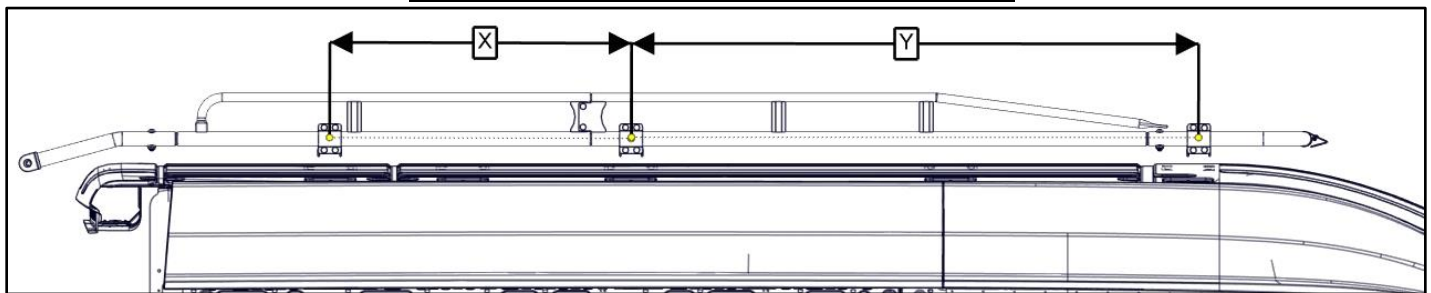

****BE SURE TO HAVE THE RACK ADJUSTED FAR ENOUGH TO THE REAR SO THAT ONE HAS
FULL FUNCTION OF THE REAR DOORS****



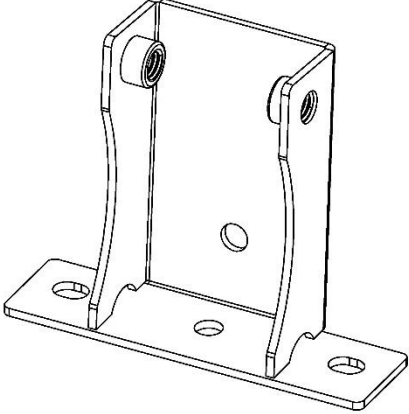

Parts

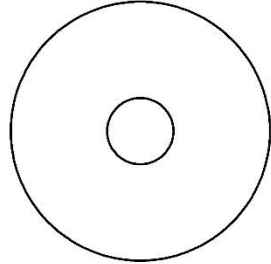
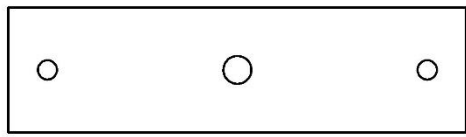
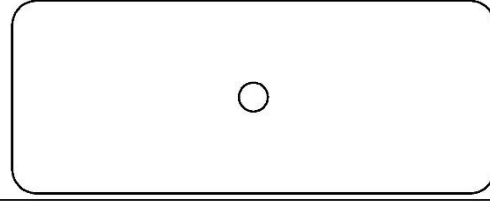
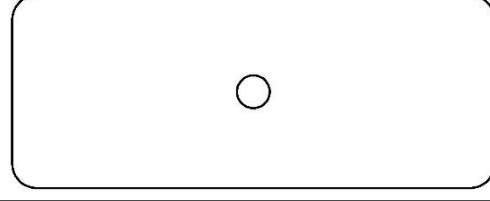
ITEM NO.		PART NUMBER	DESCRIPTION	QTY.
1		4089A-T0-004	Aluminum Foot	6
		18-4089T	Hardware Kit	1

Hardware

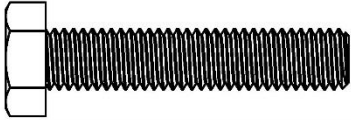
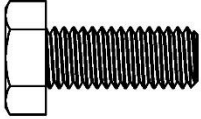
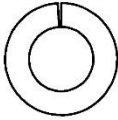
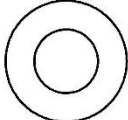
ITEM NO.	TO SCALE	PART NUMBER	DESCRIPTION	QTY.
1		.312 Fender Washer		6
2		40821-10-004-R1	3 Hole Rubber Pad 1:2	6
3		T249-02-R1	Rubber 1:2	6
4		T250-01	STEEL 1:2	6
		E6000	ADHESIVE	1

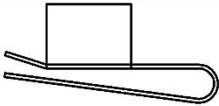
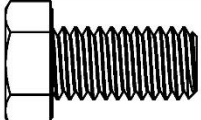
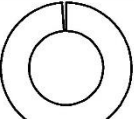
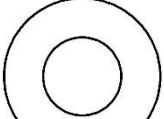
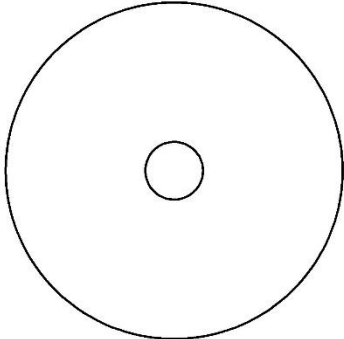
ITEM NO.	TO SCALE	PART NUMBER	DESCRIPTION	QTY.
5		91280A542	M8 x 40mm HEX HEAD	6
6		91280A530	M8 x 20mm HEX HEAD	12
7		91202A238	M8 SPLIT LOCK WASHER	12
8		91166A270	M8 FLAT WASHER	12
9		90576A117	M8 NYLOC	6
10		95210A190	M8 U- Nut	12
11		92240A622	3/8" x 3/4" HEX HEAD	12
12		92146A031	3/8" SPLIT LOCK WASHER	12
13		90126A031	3/8" FLAT WASHER	12
14		.125x.312x1.75 Rubber Washer		6

Step 1 – Find appropriate mounting locations

- Locate threaded embosses along the roof of the van. Use a tape measure to measure these locations. Compare these locations with the rack and determine which locations you would like to use. Shown below is the threaded embosses on a High Roof, Long Wheel Base Transit for reference. Mount locations will vary dependant on which vehicle rack is mounted on.

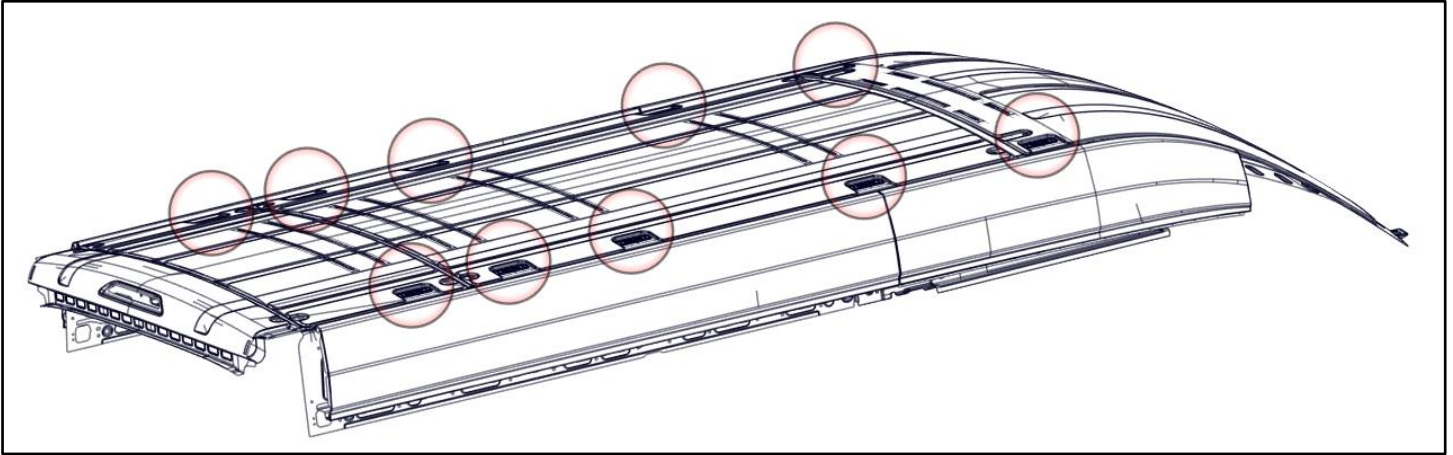

****We recommened using the rear most, middle and front most mount location on the Transit installations shown below****

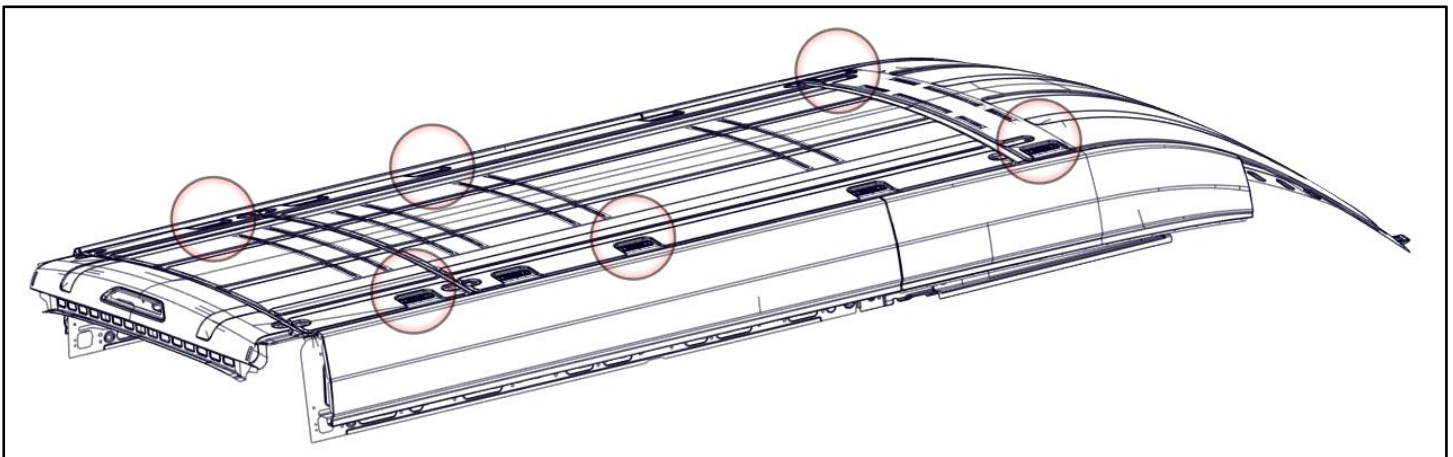

- Use the dimensions measured from the roof mount locations (X & Y) and coordinate onto the rack crossbars. Some slight adjustment will be available once rack is placed onto roof.

****BE SURE TO HAVE THE RACK ADJUSTED FAR ENOUGH TO THE REAR SO THAT ONE HAS FULL FUNCTION OF THE REAR DOORS****

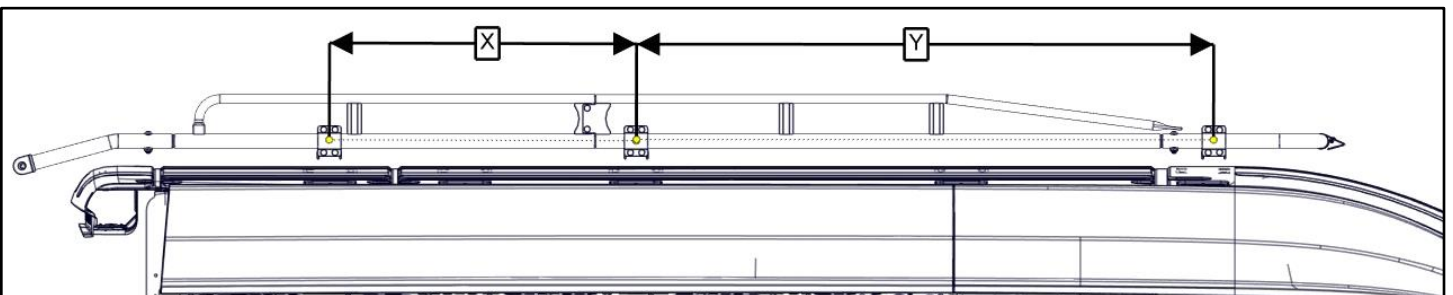

Step 2a – TRANSIT Mount Feet

- In the chosen mount locations, mount the feet using M8 x 40mm bolts with M8 lock washers and M8 flat washers.
- Be sure to put the T-249-01 and rubber pad as shown to comply with the Ford bulletin “Q249”.
- Have the opening of the foot facing to the outside of the van if possible.
- Repeat on all mount locations.
- Snug tighten, but allow for movement during rack installation.

Be sure to place E6000 in and around threaded emboss in roof to ensure no water gets into cabin of van.

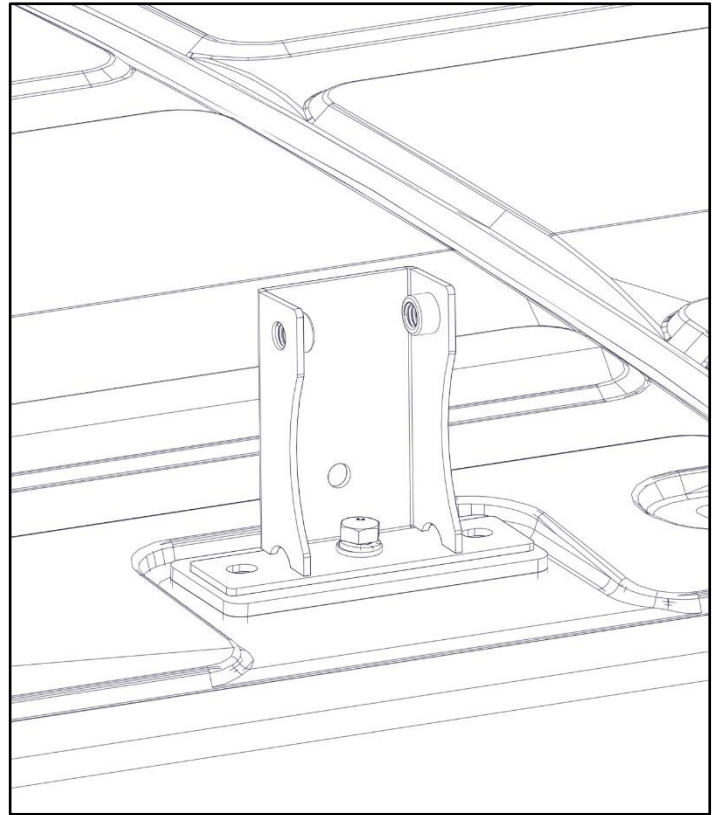
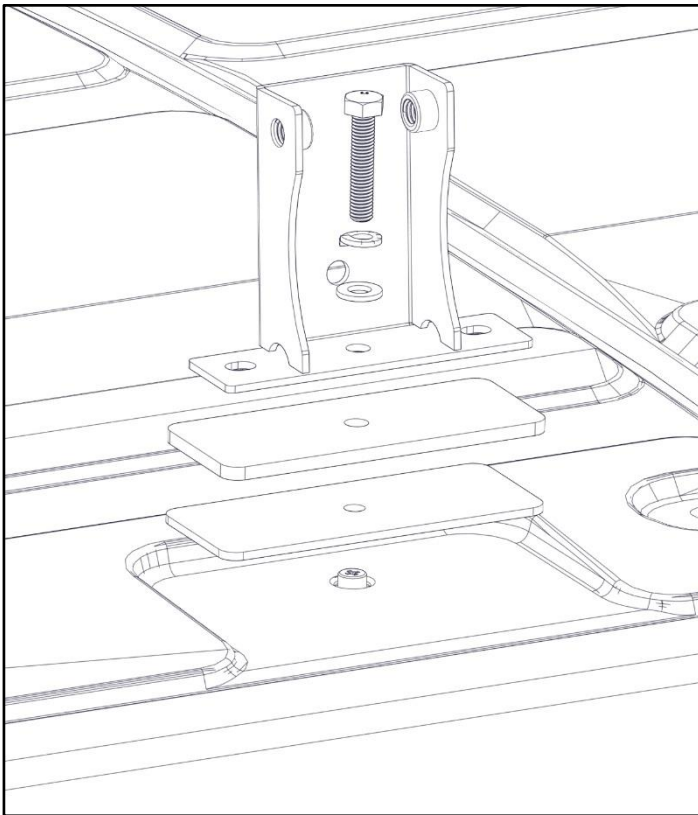

- Repeat for all other decided mount locations.

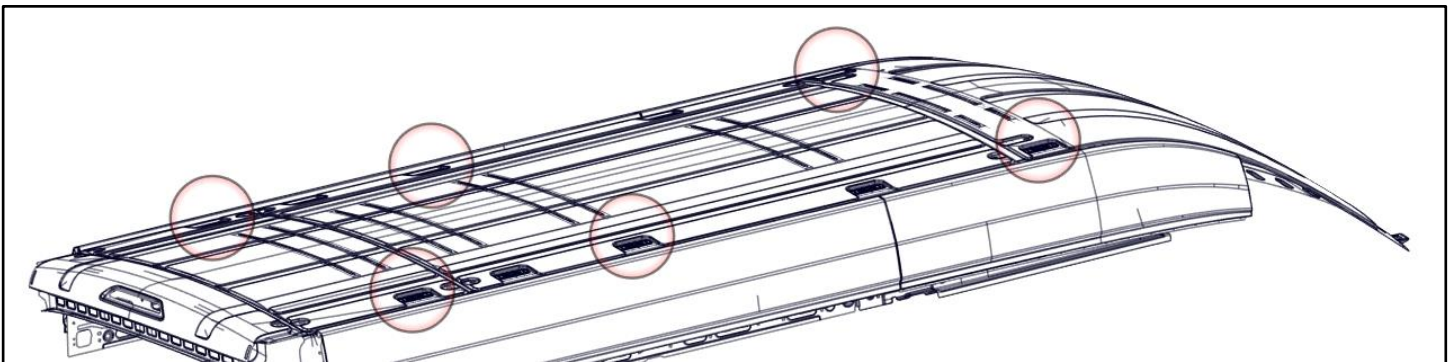

Step 2b – SPRINTER Mount Feet

- Locate the desired mount locations, or find the recommended location shown below.

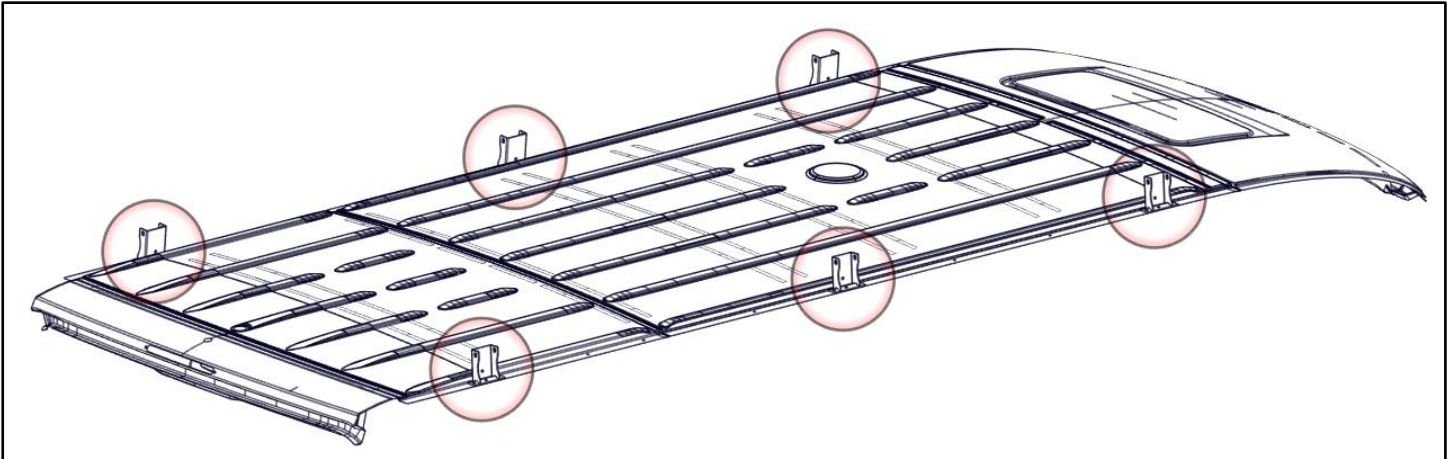

- Remove plug in roof and place the foot on top of the 3-hole rubber pad. Mount the feet using a M8 x 40mm bolt with M8 flat washer on the foot side. Be sure to place E6000 around the rubber pad and the hole in the roof.
- On the inside of the van, use the rubber washer, fender washer and M8 nyloc nut.
- Have the opening of the foot facing to the outside of the van if possible.
- Repeat at all desired locations.
- Snug tighten, but allow for movement during rack installation.

Be sure to place E6000 in and around threaded emboss in roof to ensure no water gets into cabin of van.

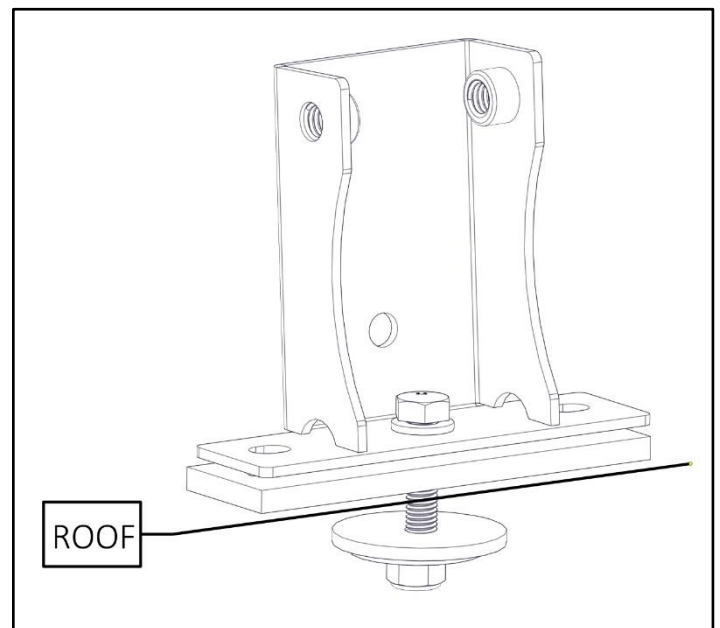
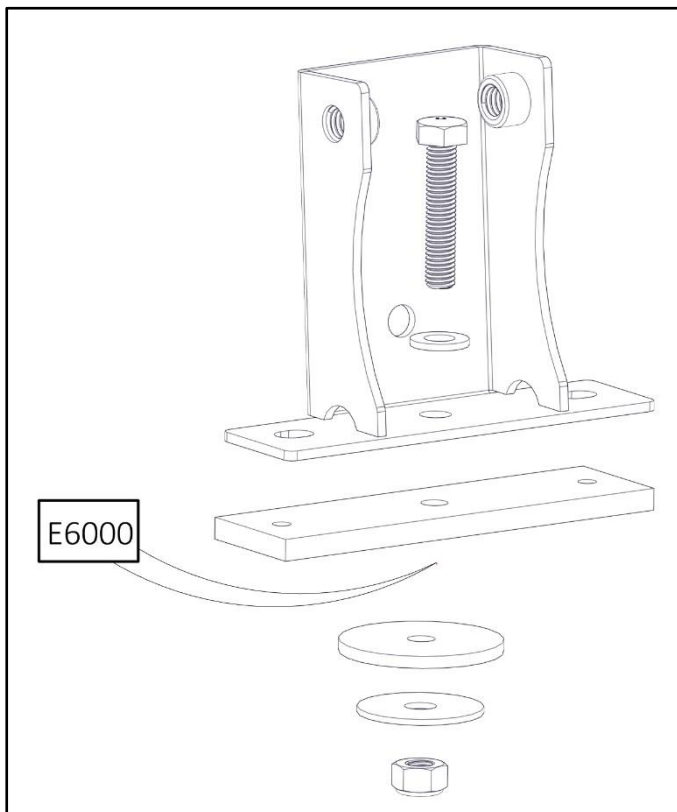

Step 2c – NV Mount Feet

- Locate nut mounts along the outer edge of the roof of the van. Determine best mount locations for your application

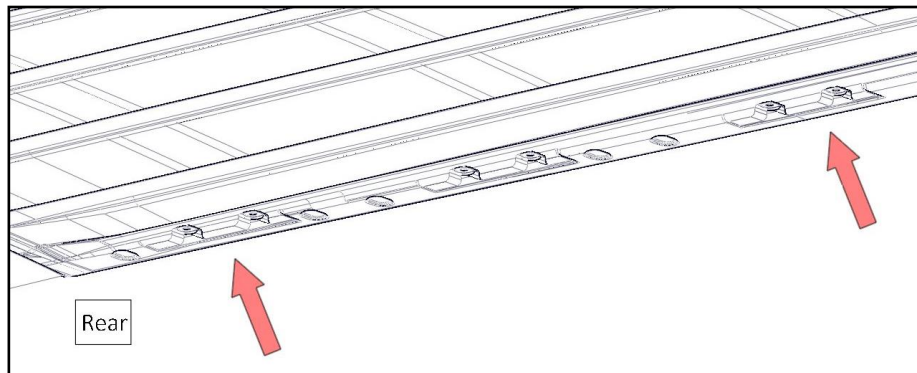
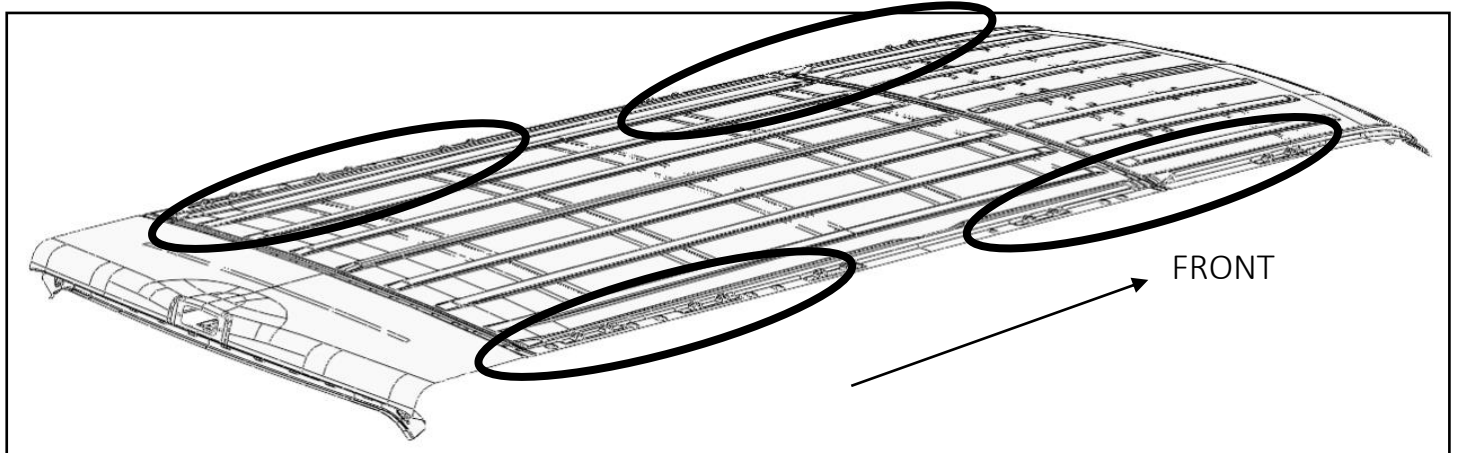

- Place foot on top of nut mounts and fasten in orientation shown. Use M8 x 20mm hex head bolt, a M8 lock washer and a M8 flat washer.
- Repeat at all desired locations.
- Snug tighten, but allow for movement during rack installation.

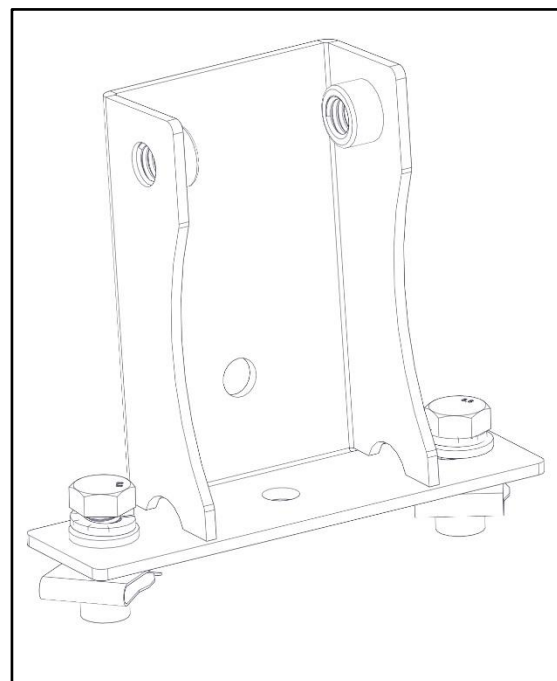
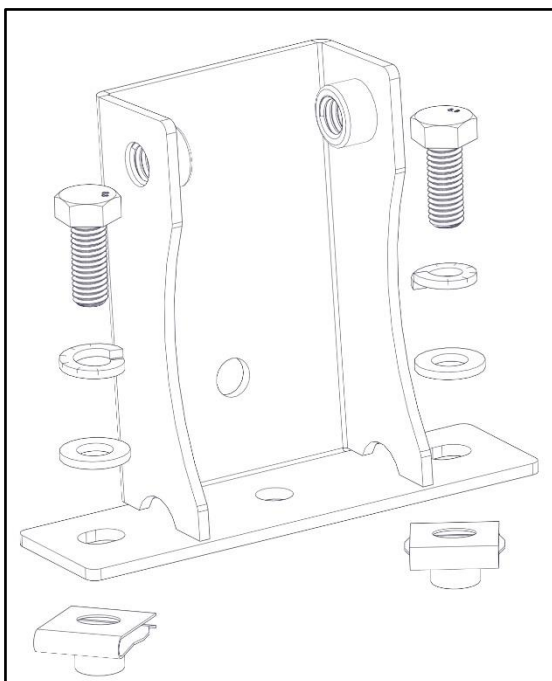

Step 3 – Mount Rack

- Follow the rack assembly instructions.
- Place rack on top of feet previously installed.
- Bolt rack crossbars to feet using 3/8" x 3/4" hex head bolts, 3/8" split lock washers and 3/8" flat washers.

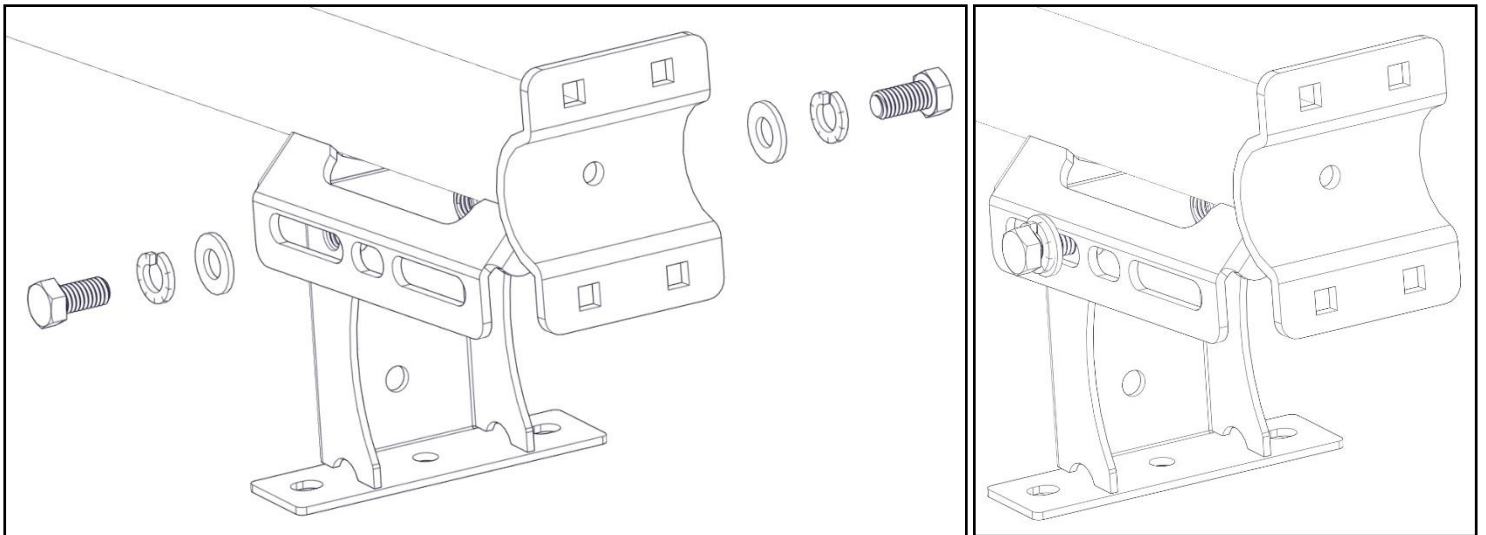
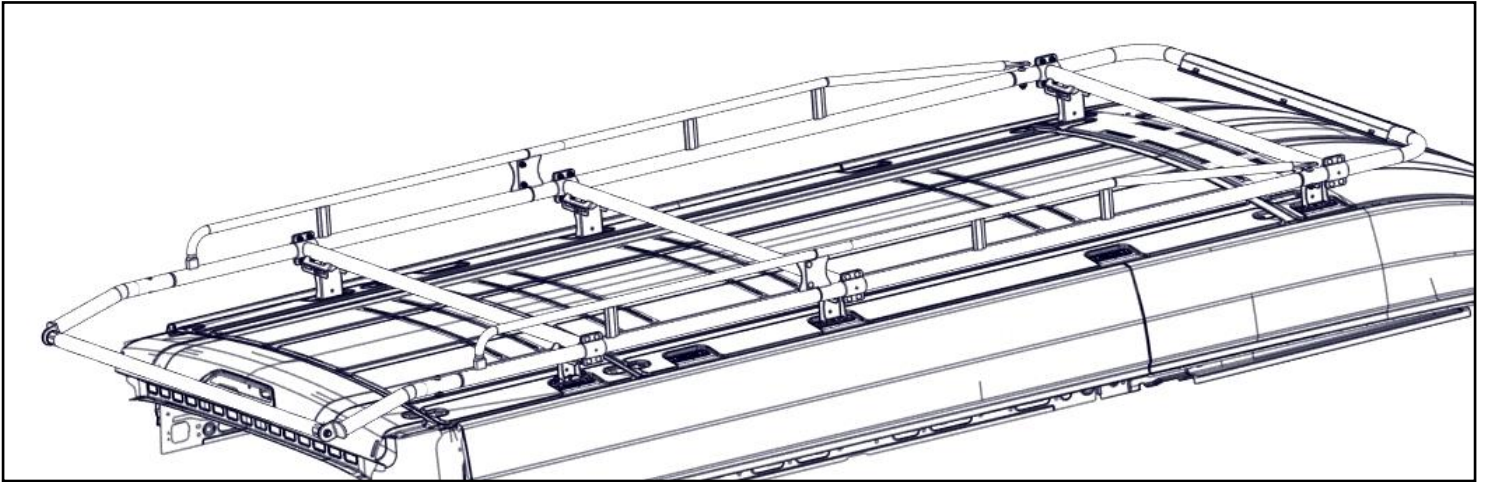

YOUR INSTALLATION IS NOW COMPLETE.

ADJUST AND ALIGN RACK TO YOUR LIKING.

Be sure E6000 was used when mounting through or into the roof to ensure no water gets into cabin of van.

KARGO MASTER[®]

WE PUT EVERYTHING WITHIN REACH.

Installation Guide

4089A

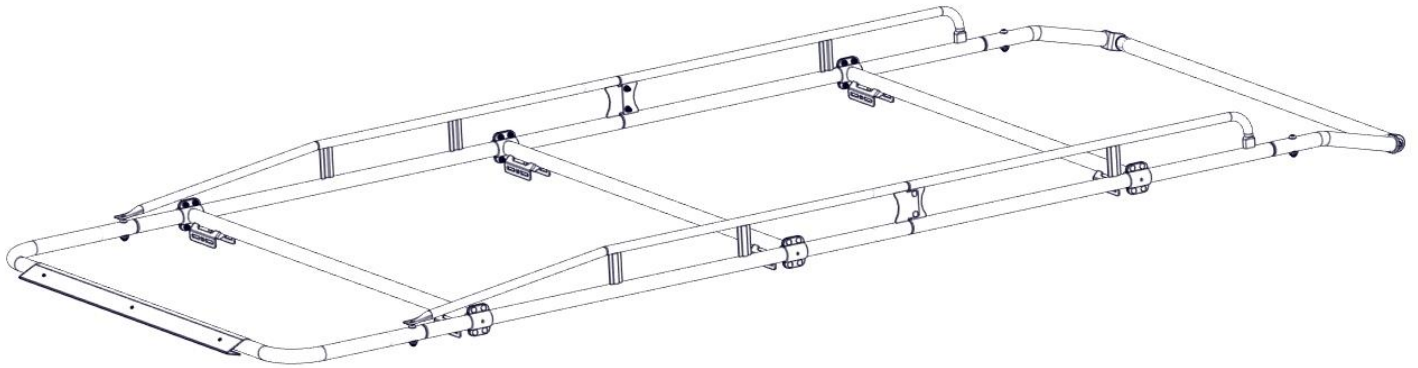

***PLEASE READ ALL INSTRUCTIONS AND WARNINGS PRIOR TO ASSEMBLING,
INSTALLING, AND USING THIS PRODUCT***

Warning



Always check for wires, fuel tanks and lines, brake lines and other important vehicle functionality items prior to drilling and installing all products.

Tools Needed

1/2" Socket and Wrench	9/16" Socket and Wrench
5/16" Allen Hex	3/4" Socket and Wrench
13mm Socket and Wrench	10mm Socket and Wrench

Before You Begin

- Read all instructions.
 - Be sure to put sealant along the swage joints and all threads connecting tubes together. This is to prevent water from getting into the tubing and causing rust issues.
 - During installation onto the vehicle, place sealant around all threads entering the cargo area and between the rubber spacer and roof of the vehicle to prevent water from leaking through to the cargo area as well.
 - Follow mount kit instructions to install on vehicle.
-

GOOP APPLICATION

Apply a healthy air tight bead of goop around **every** swaged joint as shown, to prevent moisture from leaking into and out of the joint. If this is not done properly, the inside surface of the tubes can rust and rusty water can leak out. Maintain this joint seal throughout the life of your rack.

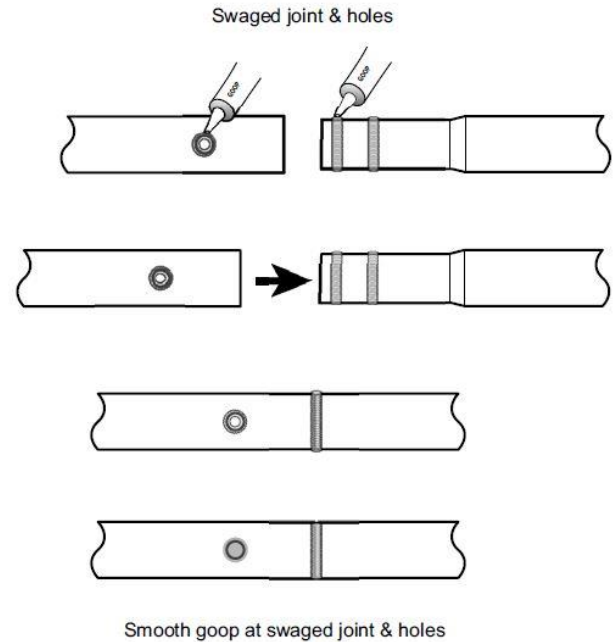





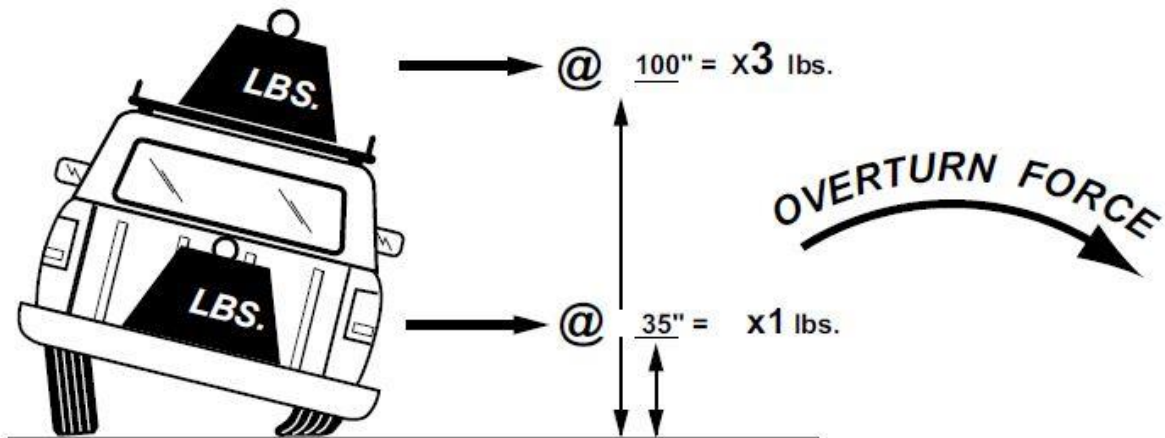

DON'T OVERLOAD YOUR VEHICLE!

TMCS_3:1

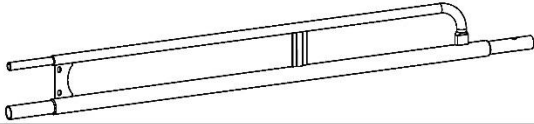
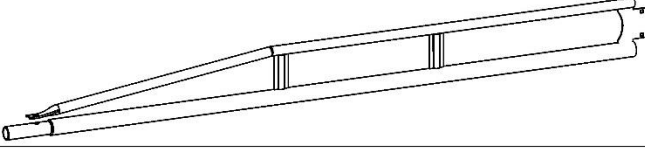
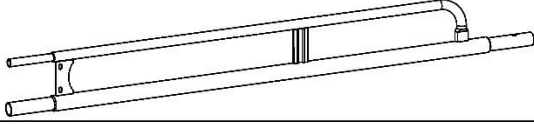
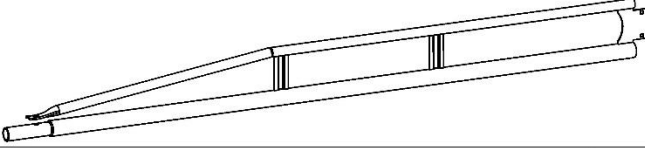
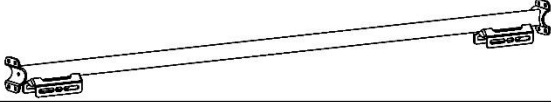

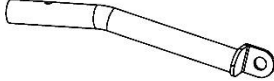
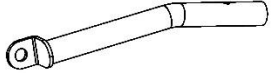
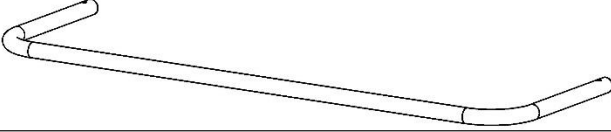

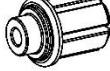

WEIGHT CARRIED ABOVE THE FLOOR OF THE TRUCK BED (E.G. ON AN OVERHEAD TRUCK RACK) WILL SIGNIFICANTLY INCREASE THE VEHICLE'S TENDENCY TO OVERTURN. ALWAYS KEEP HEAVY LOADS EVENLY DISTRIBUTED AND AS LOW AS POSSIBLE. IT IS IMPORTANT TO NOTE THAT THE KARGO MASTER RACK LOAD BEARING CAPACITY MAY BE GREATER THAN YOUR TRUCK'S GAWR OR GVWR CAPACITY, AND IS PROBABLY GREATER THAN THE WEIGHT THAT CAN BE SAFELY CARRIED OVERHEAD.

Parts

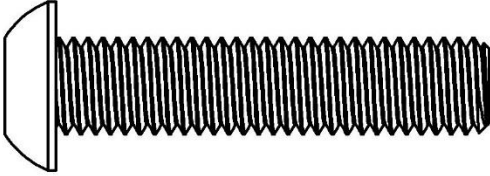
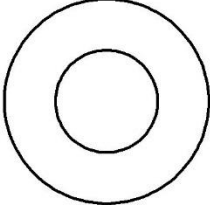
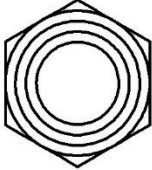
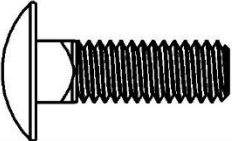
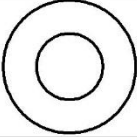
ITEM NO.		PART NUMBER	DESCRIPTION	QTY.
A		8009A-01	WELDMENT, RAIL, SIDE, LEFT, AFT	1
B		8009A-02	WELDMENT, RAIL, SIDE, RIGHT, FORWARD	1
C		8009A-03	WELDMENT, RAIL, SIDE, RIGHT, AFT	1
D		8009A-04	WELDMENT, RAIL, SIDE, LEFT, FORWARD	1
E		8009A-05	WELDMENT, CROSS-TUBE, SUPPORT	3
F		8009A-RB-1	ROLLER BAR, ALUMINUM RACK	1
G		8009A-RB2	ROLLER BAR, REAR, PS, ASM	1
H		8009A-RB3	ROLLER BAR, REAR, DS, ASM	1
J		8009A-00-001	TUBE, FRONT, ALUMINUM RACK	1
K		8009A-00-013	BRACKET, CAP, CROSSBAR	6
L		4089A-00-023-R1	DEFLECTOR, WIND, ALUMINUM RACK	1
M		4089A-00-24-R1	BRACKET, CLAMP, WIND DEFLECTOR	3
N		4A829-06-M	FITTING, MOLDED	2
		18-00812A	KIT, HARDWARE	1

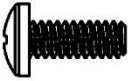
Assembly Hardware (18-00812A)

ITEM NO.	TO SCALE	PART NUMBER	DESCRIPTION	QTY.
1		91255A050	BOLT, BUTTON, SOCKET, 1/2-13 X 2.25", SS	4
2		90126A033	WASHER, FLAT, 1/2", SAE, SS	4
3		94945A224	NUT, HEX, JAM, 1/2-13, NYLOC, SS	4
4		90185A583	BOLT, CARRIAGE, 5/16-18 X 1, SS	28
5		90126A030	WASHER, FLAT, 5/16", SAE, SS	28
6		95615A160	NUT, 5/16-18, NYLOC, SS	28
7		96562A242	SCREW, PHILLIPS, 10-24 X .5, SS, NYLOC	3
8		BH-821	SEALANT	1

Step 1 – Determine Distance Between Feet

- On the roof of the van, determine desired mounting locations. Measure between the locations. This distance will determine the distance between the cross bar assemblies of the rack. (Transit Roof Shown)

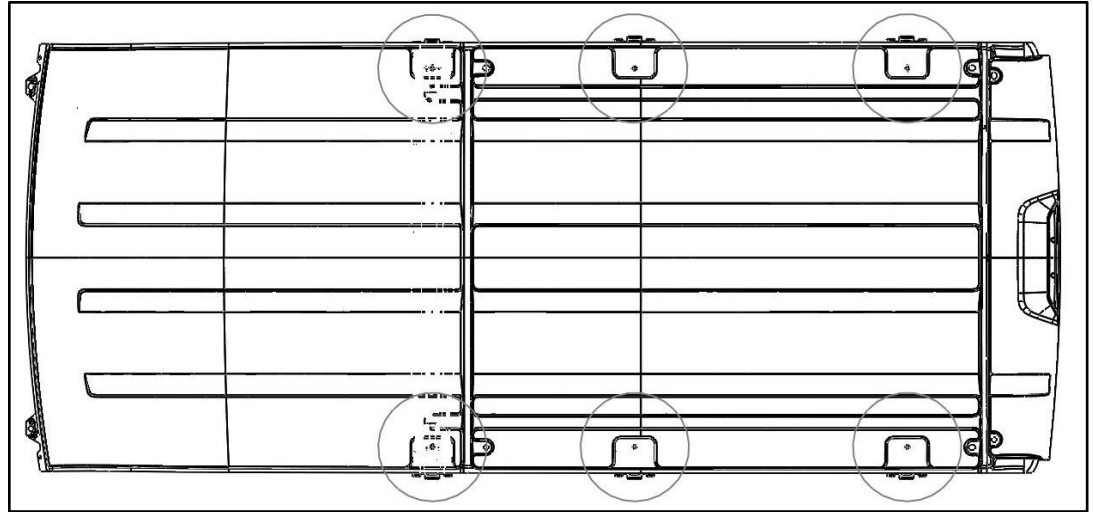

Step 2 – Assemble Side Channels

- Assemble side channels by connecting front and rear pieces. Left and right pieces are identical, so it does not matter which of the two is used. The sheet metal brackets will align when the parts are assembled properly. See pictures.
- Bolt using two 5/16 carriage bolts, two 5/16 flat washers and two 5/16 nyloc nuts. Repeat for a total of two rail assemblies.

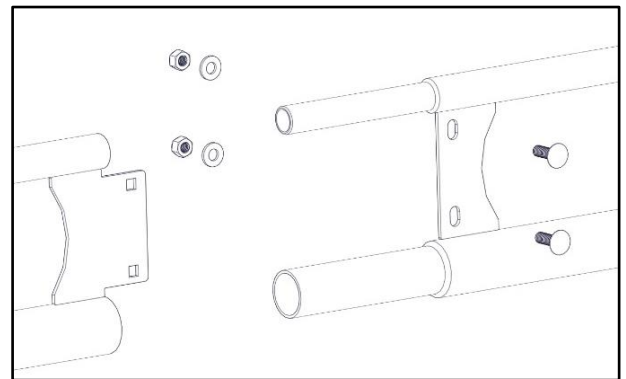

****Be sure to apply sealant around tube connections****

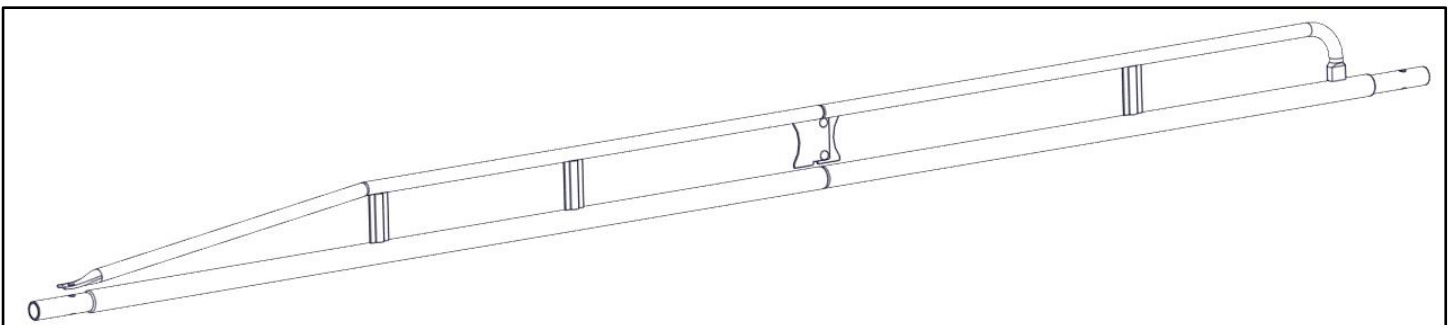
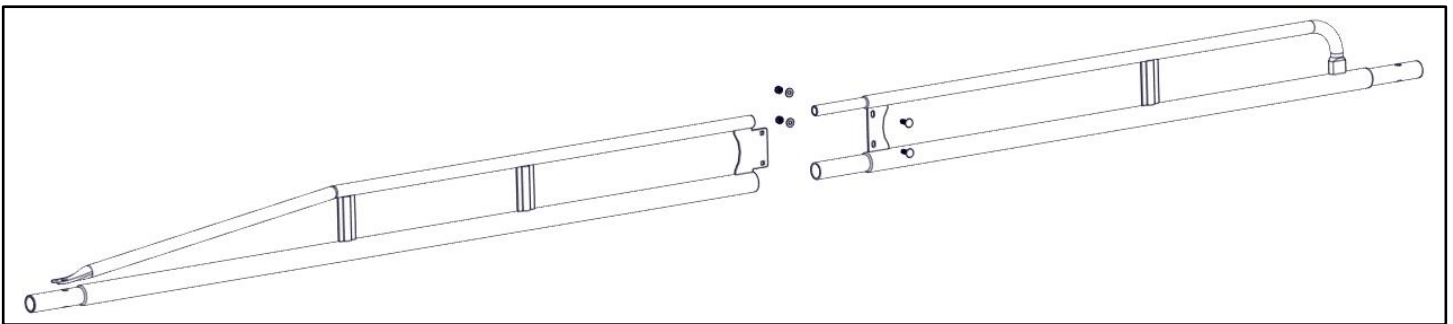

Step 3 – Assemble Rack

- Assemble the rack as shown below.
- Use the distances measured from step one to approximate where the cross bars should go.
- Do not assemble any part of the rear roller bar assembly.

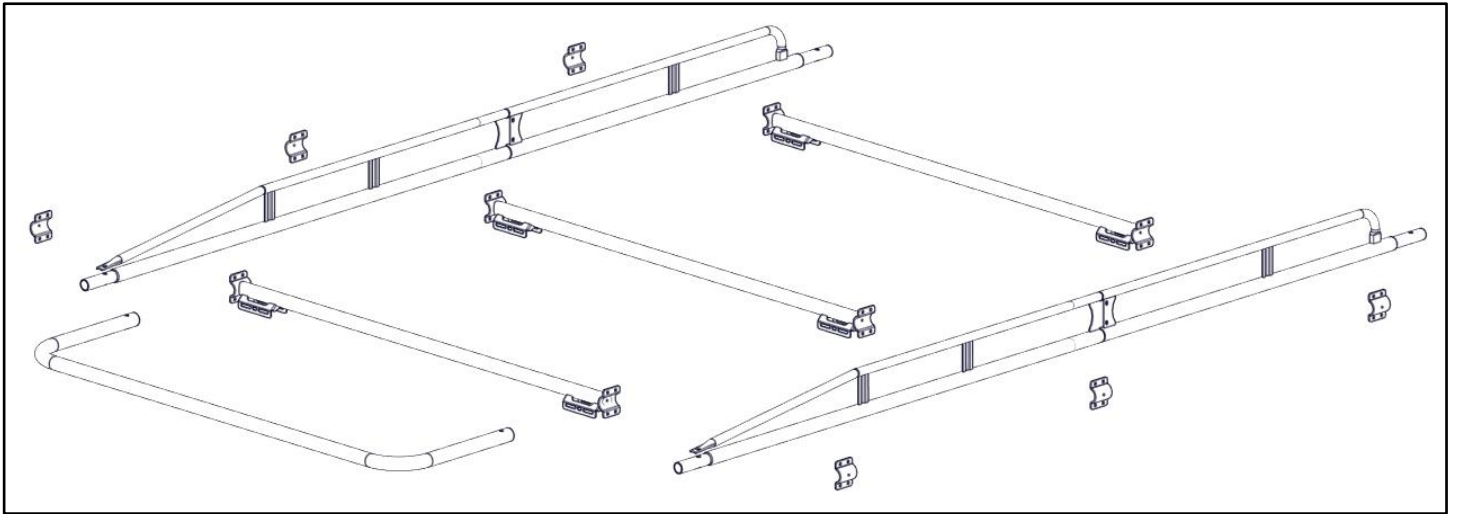

- Once crossbars are in desired position, bolt clamp to crossbars using four 5/16" x 1" carriage bolts, four 5/16" flat washers, and four 5/16" nyloc nuts.
- Tighten, but allow some movement. Adjustment will be needed when installing onto vehicle.

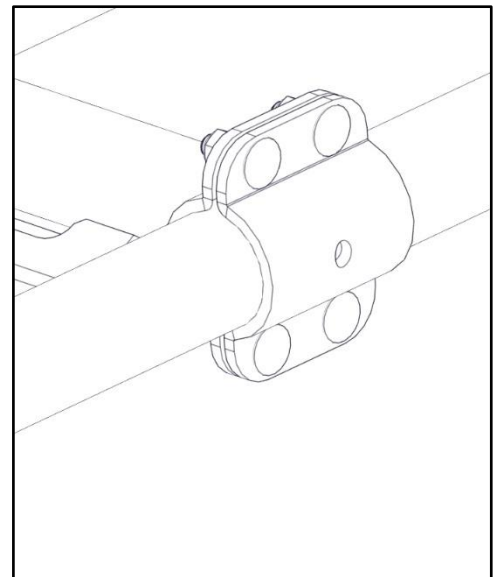
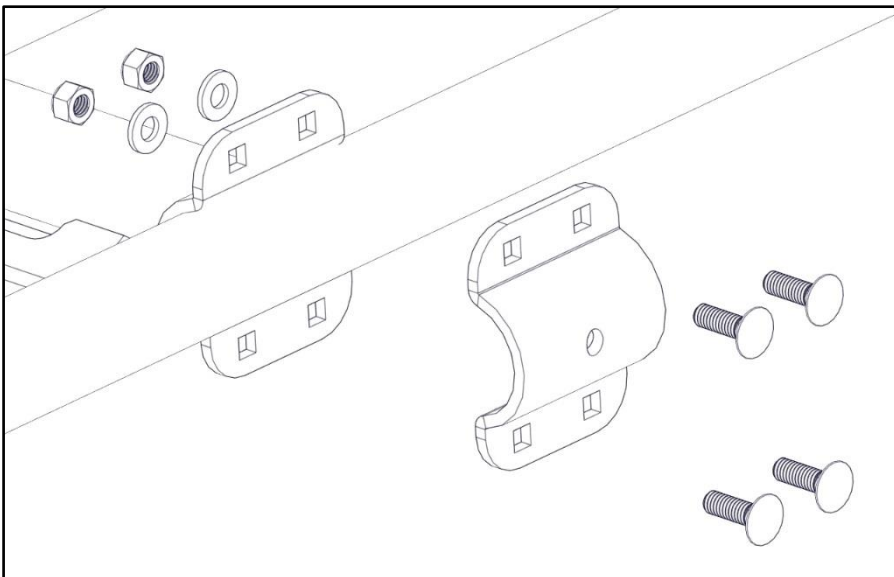

- Bolt front hoop to both side rails using a 1/2" x 2-1/4" button head (BHCS), a 1/2" flat washer, and a 1/2" nyloc nut.
- Be sure to place sealant along the swage joint.
- Place sealant around the exposed hole to prevent water from entering the tube.
- Repeat on both sides.

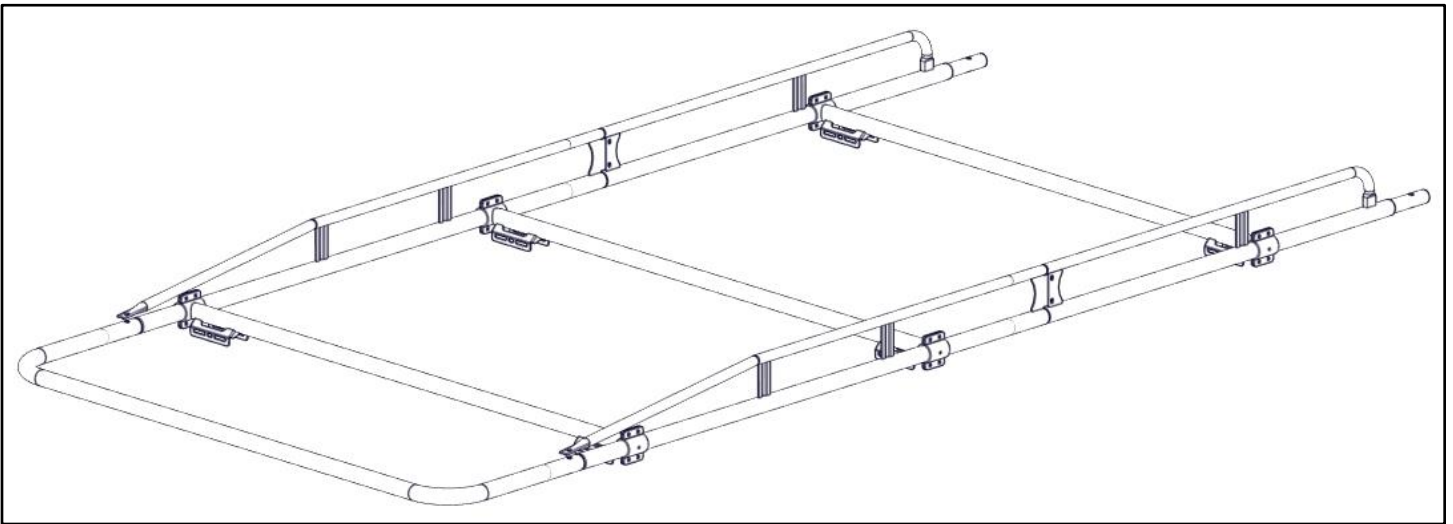
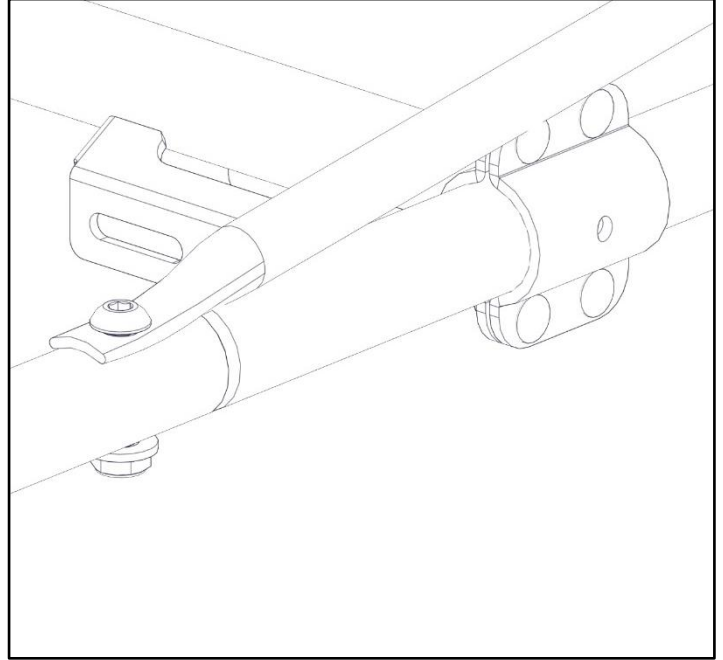
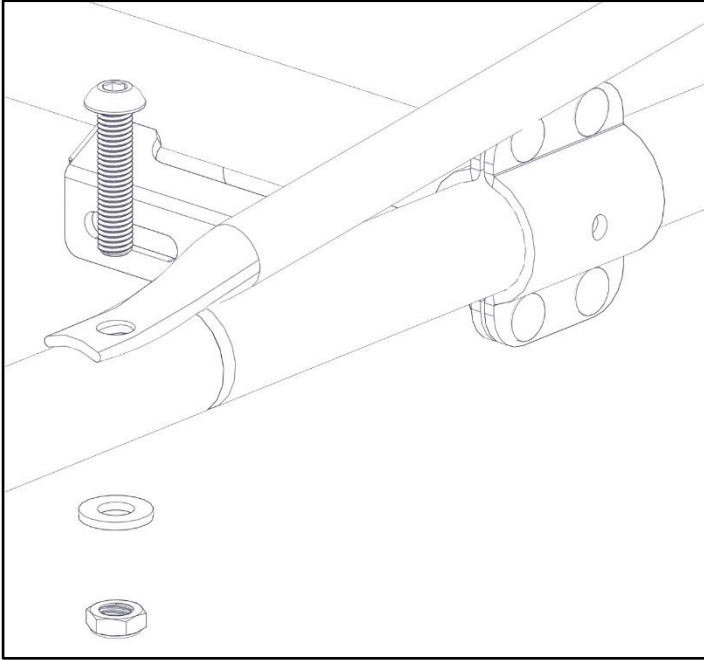

Step 4 – Assemble Rear Roller Bar

- Insert plastic bushings into the end of the roller bar as shown.
- Bolt roller bar with bushings to the roller bar side assembly using 3/8" oversize washer and 3/8" x 2-1/2" hex head bolt.
- Do NOT tighten.
- Bolt both roller bar side assemblies with the rear roller bar to the ends of the side channels using 1/2" x 2-1/4" button head cap screws (BHCS), 1/2" flat washers, and 1/2" jam nylocs.
- Place sealant around the 1/2" holes to prevent water from leaking into tubes.
- Once all pieces are attached to the main assembly, tighten.
- Be sure to place sealant on all swage joints.

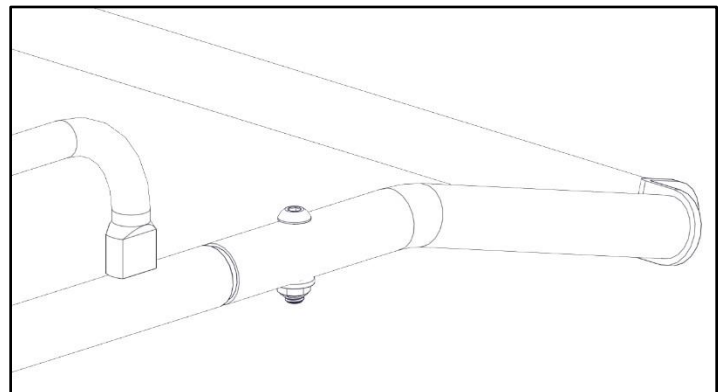
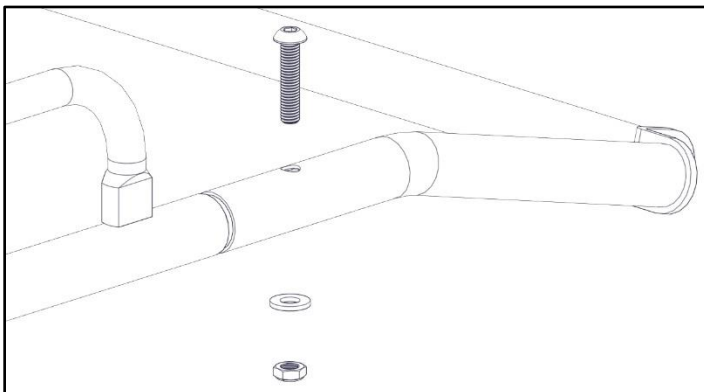
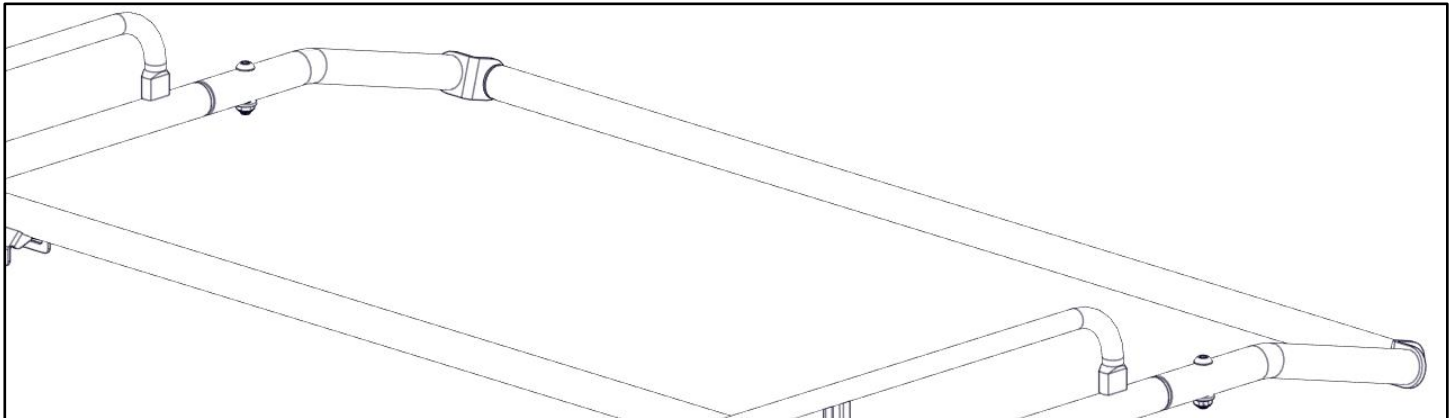
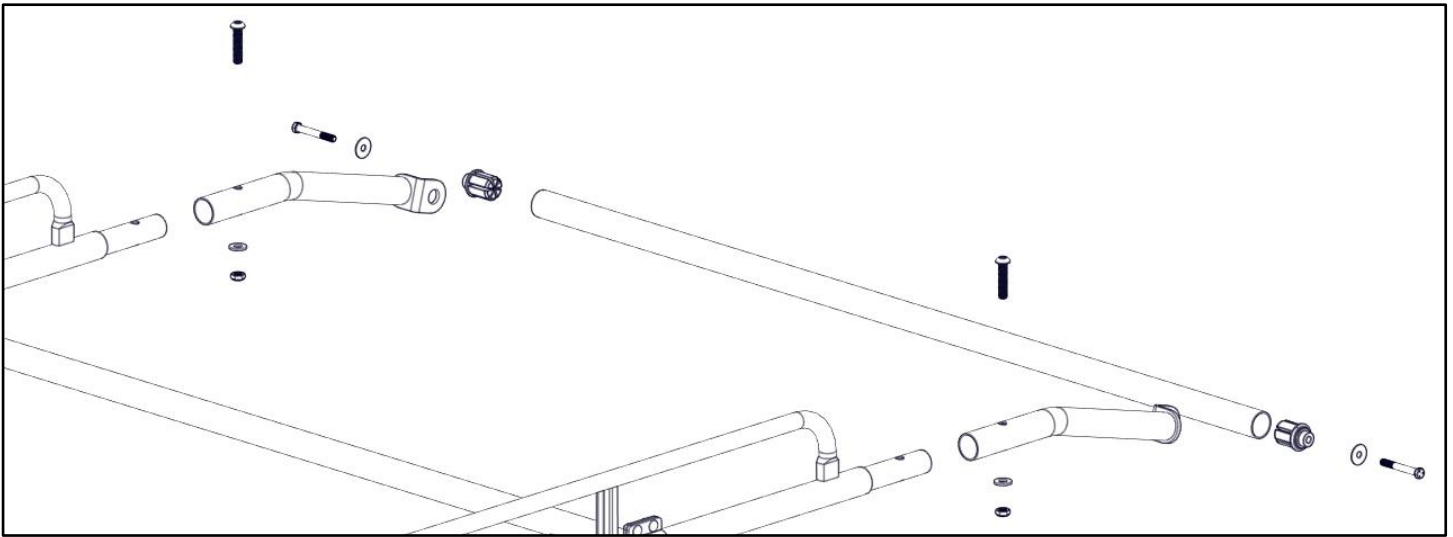

Step 5 – Install Wind Deflector

- Place wind deflector along the front hoop. Some adjustment may be needed once vehicle is driven to minimize road noise.
- Position clamp so it hooks in the slot of the wind deflector and goes around the front hoop.
- Bolt through the wind deflector and into the clamps using a #10 x 1/2" pan head screw.
- Repeat for a total of 3 times.

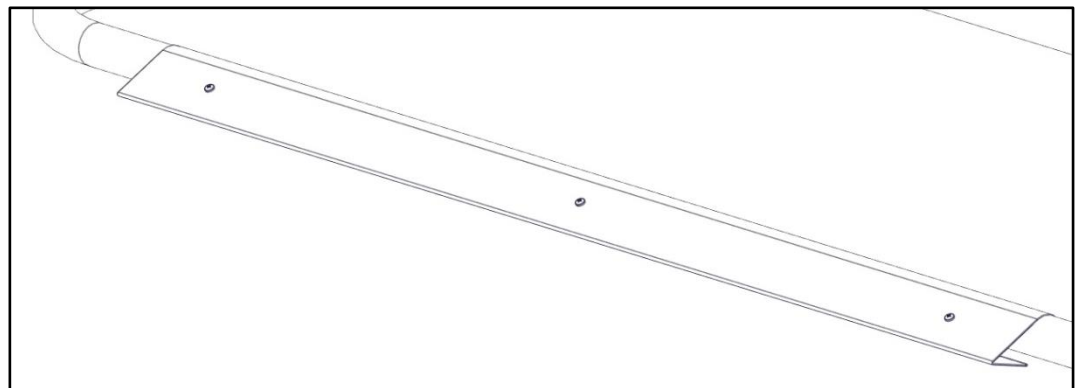
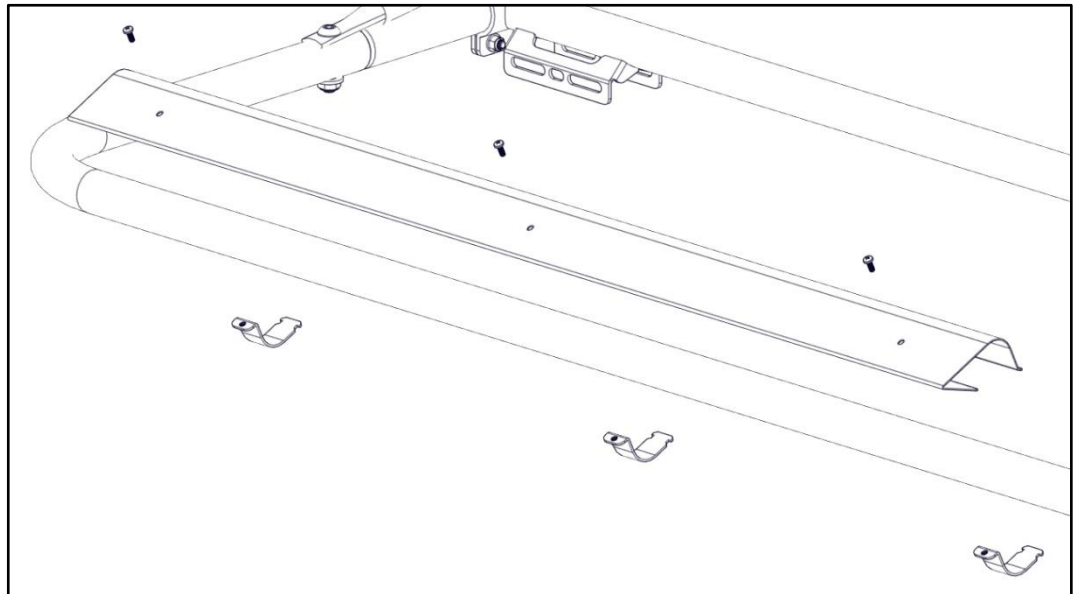
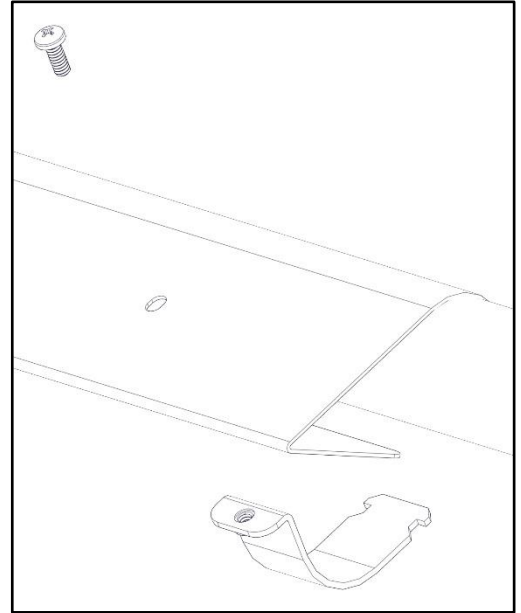
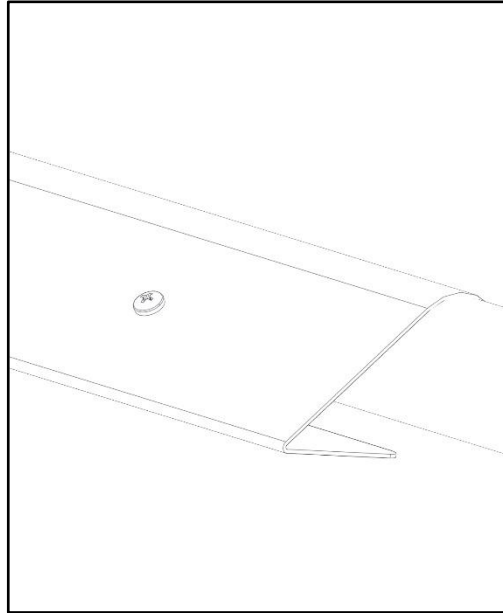

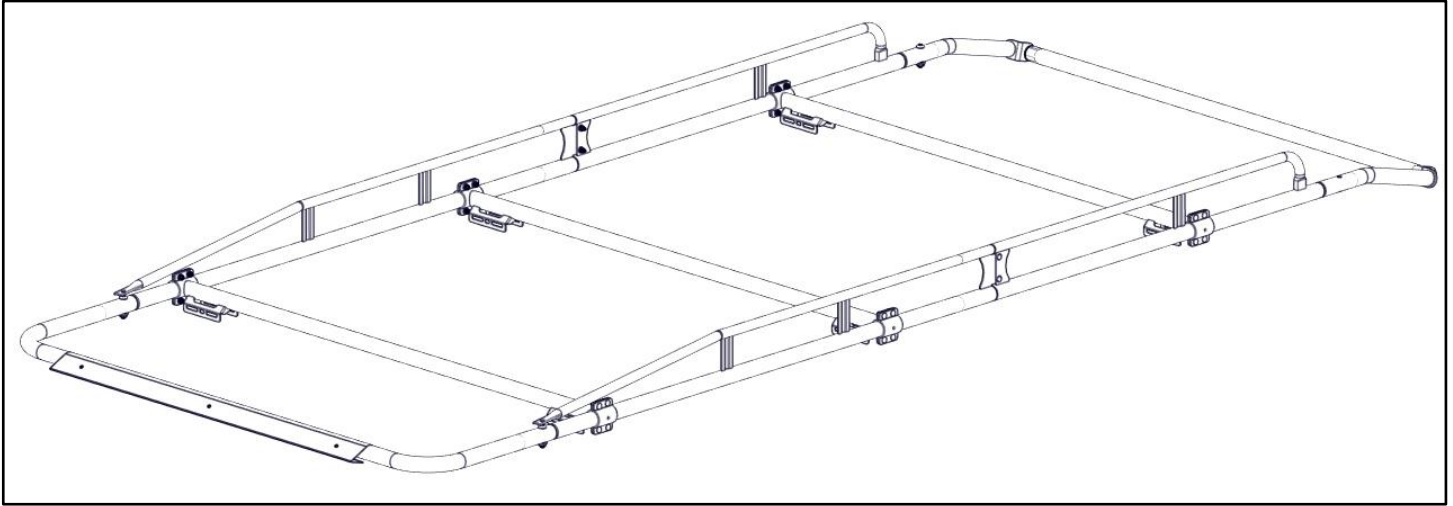

GO BACK AND MAKE SURE ALL HARDWARE IS TIGHT.

YOUR ASSEMBLY IS NOW COMPLETE.

Follow the mount kit instructions in the mount kit box to finish the installation.

Note: Some adjustment on the wind deflector may be needed after driving and evaluating the wind noise.