

KARGO MASTER[®]

WE PUT EVERYTHING WITHIN REACH.

4089C Instructions

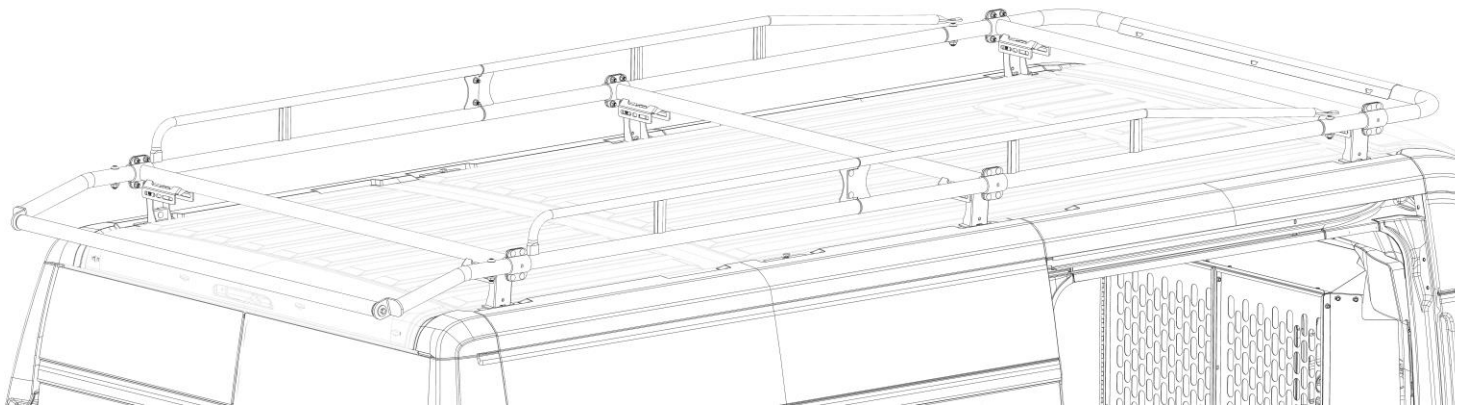

***PLEASE READ ALL INSTRUCTIONS AND WARNINGS PRIOR TO ASSEMBLING,
INSTALLING, AND USING THIS PRODUCT***

Warning



Always check for wires, fuel tanks and lines, brake lines and other important vehicle functionality items prior to drilling and installing all products.



Tools Needed

1/2" Socket and Wrench	9/16" Socket and Wrench
Tape Measure	



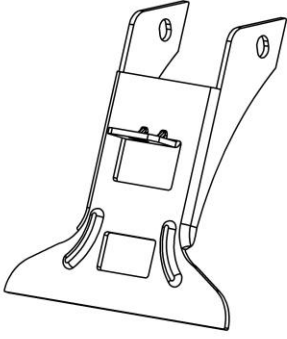

Before You Begin

- Read all instructions.
 - Follow assembly instructions found with the rack to assemble and install rack.
 - The 3/8" hardware will be used when installing the rack to the feet.
-

Parts

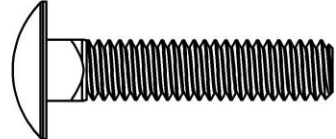
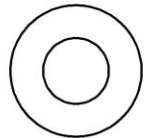
ITEM NO.		PART NUMBER	DESCRIPTION	QTY.
A		11-00389-R2	BRACKET, GUTTER MOUNT	6
B		11-02085-RIB-R2	BRACKET, CLAMP, GUTTER MOUNT	6
		18-4089C	HARDWARE KIT	1

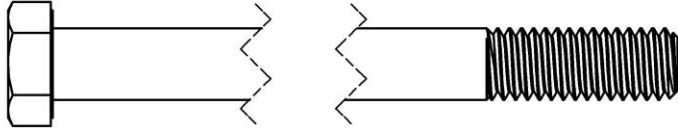
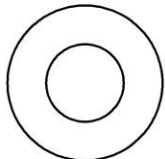
Hardware 18-4089C

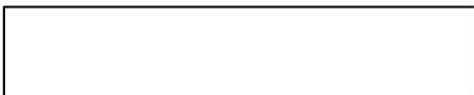
ITEM NO.	TO SCALE	PART NUMBER	DESCRIPTION	QTY.
1		92356A587	5/16"-18 X 1-1/2 CARRIAGE	6
2		90126A030	5/16" WASHER	6
3		95615A160	5/16"-18, NYLOC	6
4		91247A640	3/8-16 X 4" HEX HEAD	6
5		90126A031	3/8" WASHER	12
6		95615A140	3/8-16 NYLOC	6
7		8009A-00-25-R2	SPACER, 3/8" ID, 1/2" OD, 2.5" LG,	6

Step 1 – Find Mount Locations on Roof of Van

- Locate the mounting locations on each side of van. There will be a rain gutter along the edge of the roof.

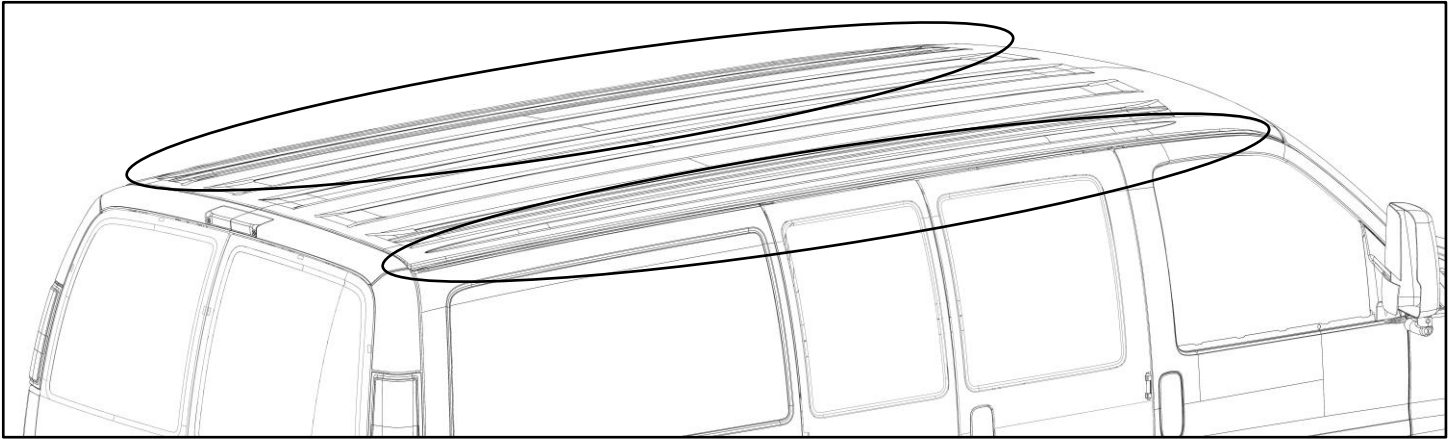

- Determine distance between each cross bar that is to be used to attach to roof. See picture below for reference.
- Take this measurement into consideration when assembling the rack.

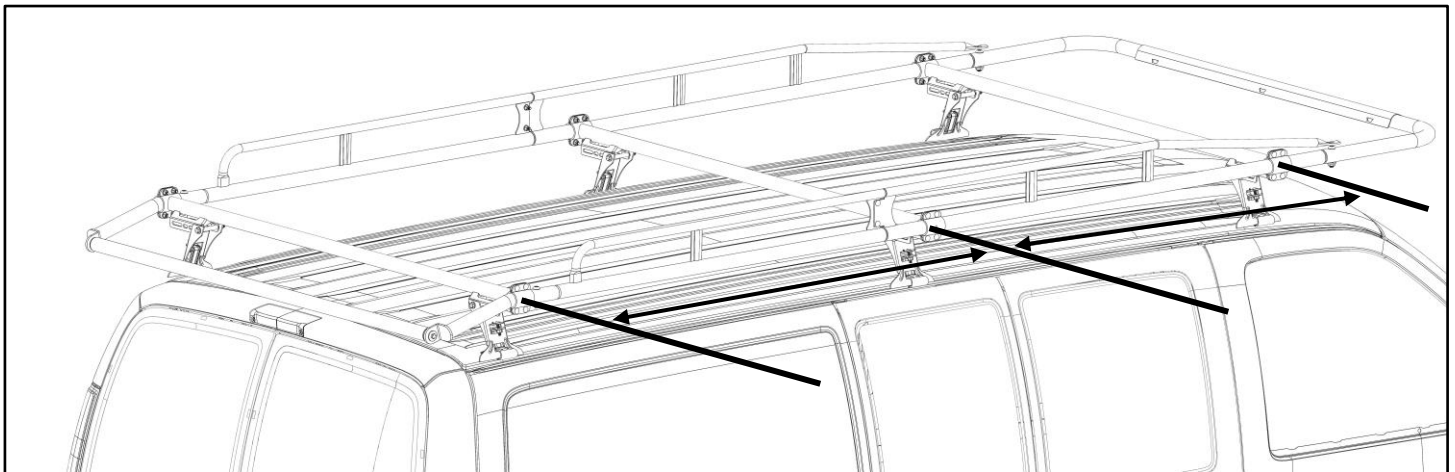

Step 2 – Attach Feet to Rack

- Use the crossmember from the rack box and attach foot in the orientation shown using 3/8" x 4" hex head bolt, two 3/8" flat washers, 3/8" spacer and a 3/8" nyloc nut.
- Attach foot through the inner most slot on the crossmember as shown.
- Repeat for a total of 6x.

Shown without the rest of the rack for clarity

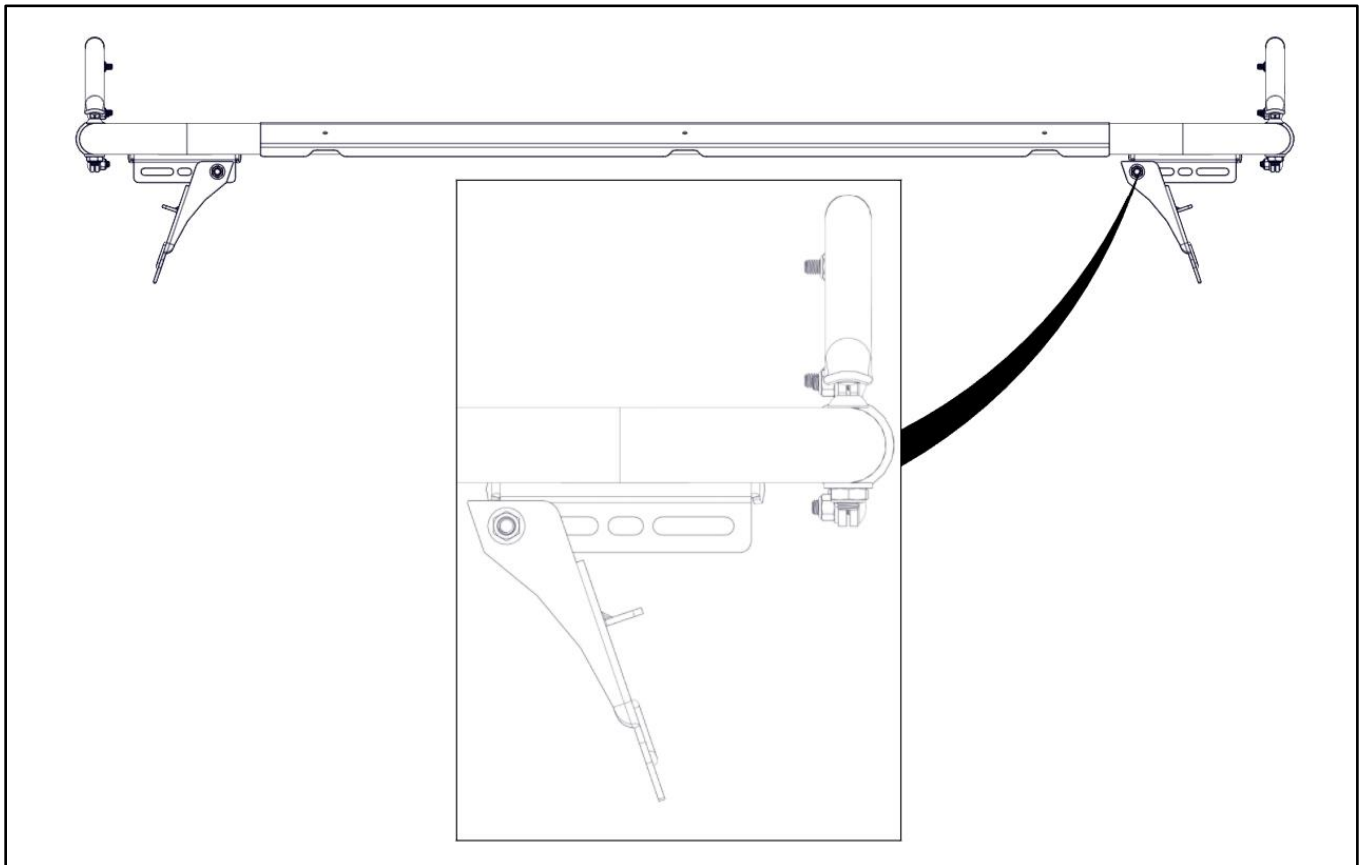
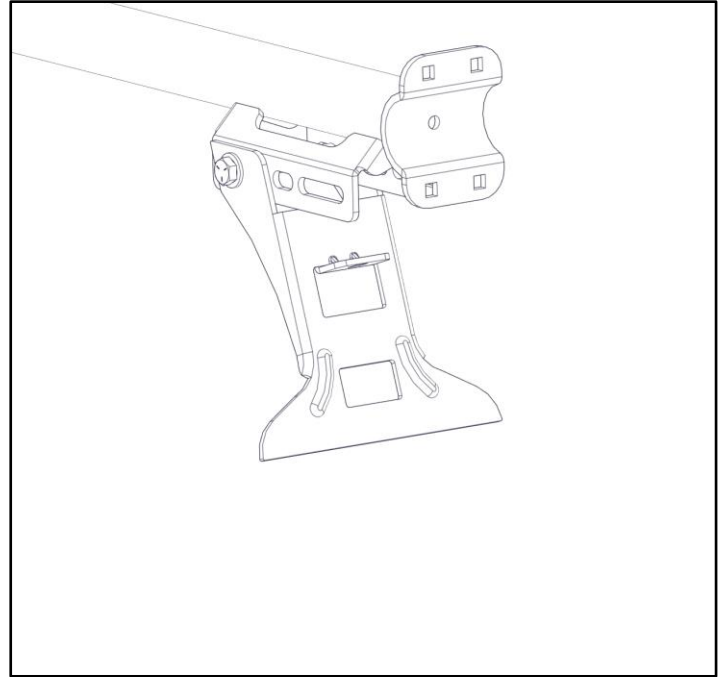
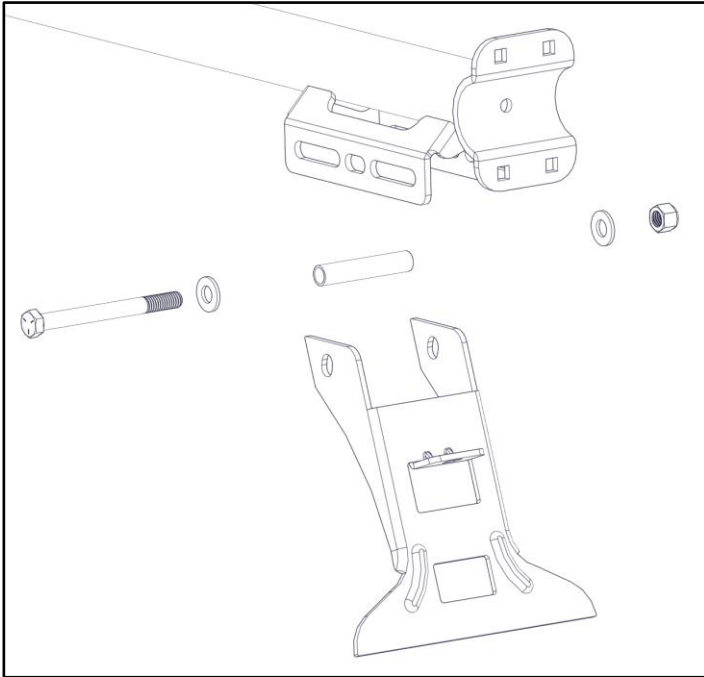

Step 3 – Install Rack with Feet

- Place rack onto roof of van. Be sure the feet installed in previous step goes onto the rain gutter flange.

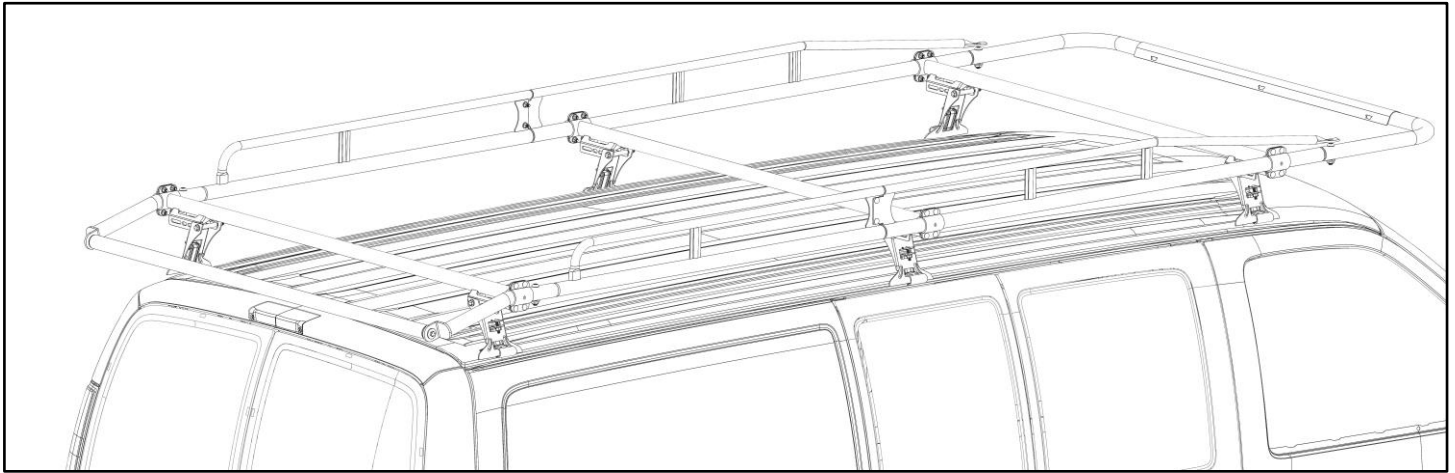

- Adjust and center rack to your liking.
- Slide foot mount bracket through the foot. Pinch the rain gutter in between the mount bracket and the foot. Bolt into place using 5/16" x 1-1/2" carriage bolt, 5/16" flat washer and 5/16" nyloc as shown.
- Repeat for a total of 6x.
- Once rack is in desired location on roof of van, **TIGHTEN** all bolts.

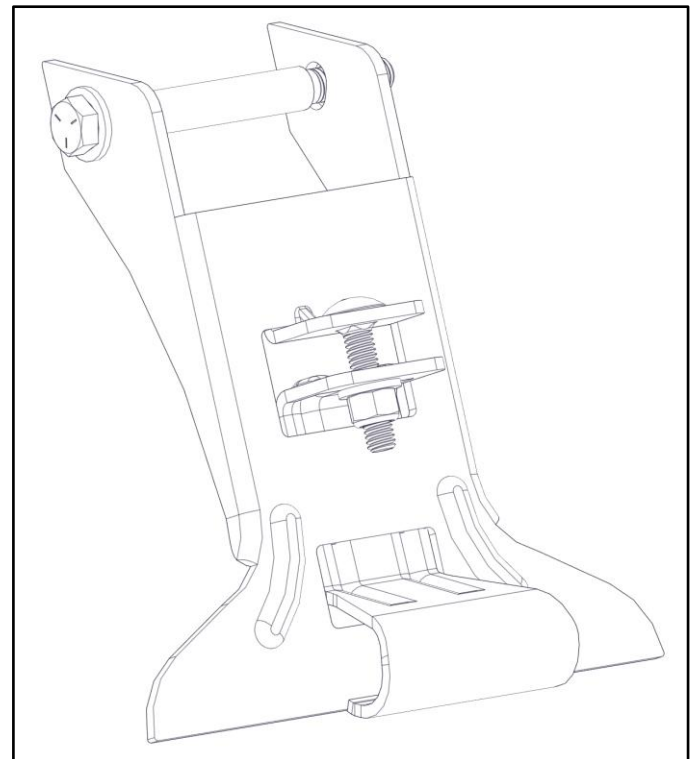
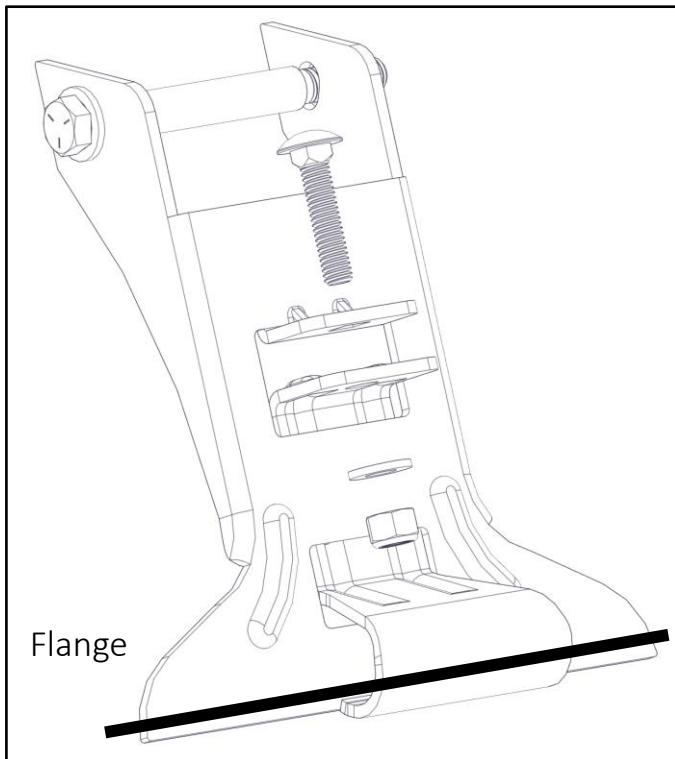

shown without rack and van for clarity

Go back and tighten all bolts on rack.

Your installation is now complete.

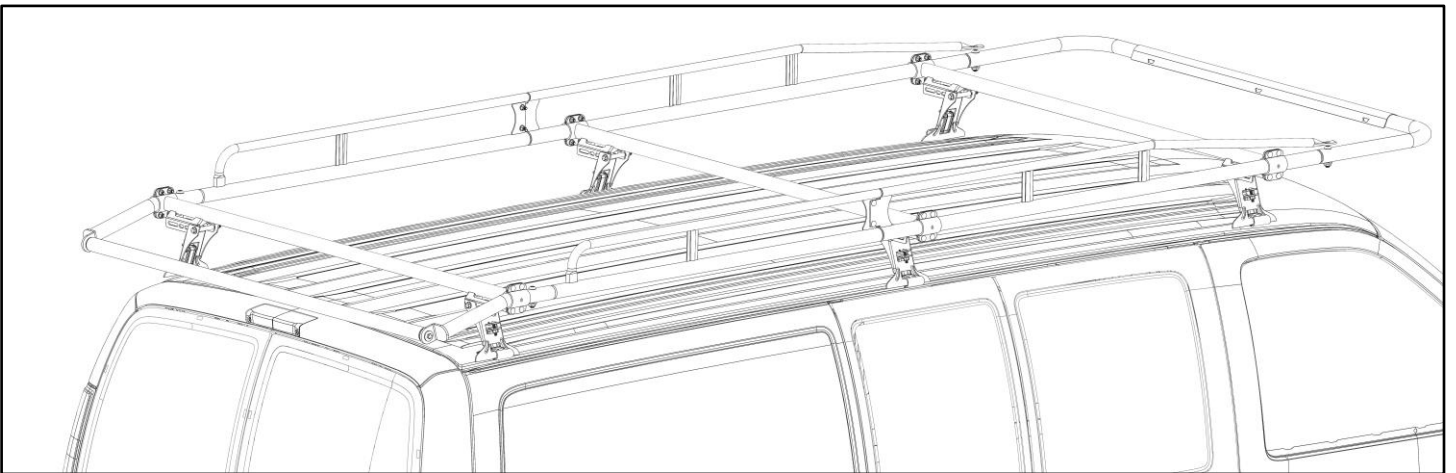

KARGO MASTER[®]

WE PUT EVERYTHING WITHIN REACH.

Assembly Guide

40890

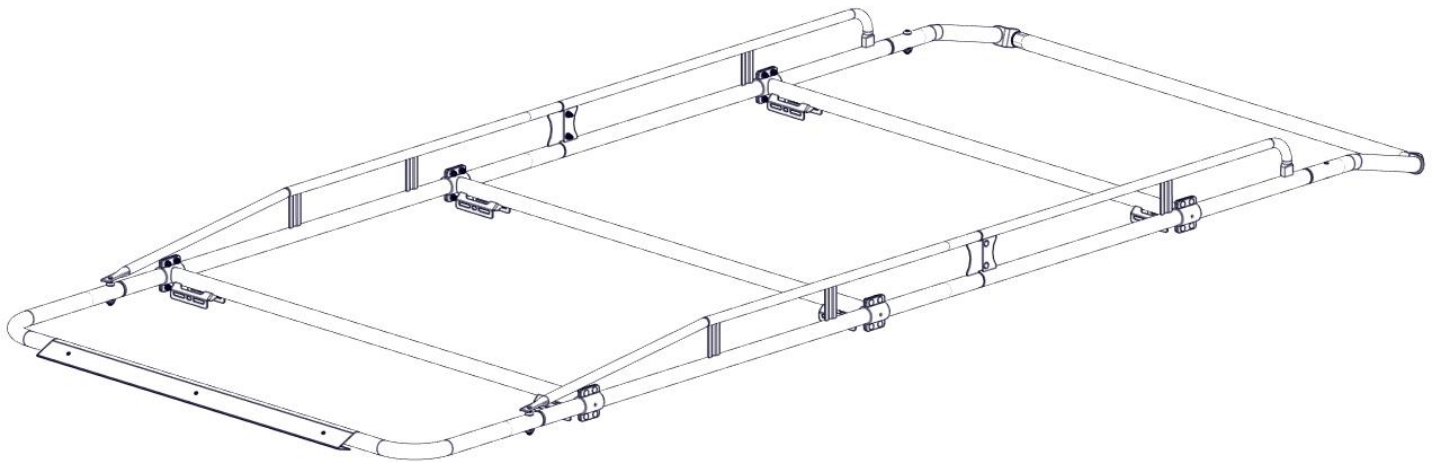

***PLEASE READ ALL INSTRUCTIONS AND WARNINGS PRIOR TO ASSEMBLING,
INSTALLING, AND USING THIS PRODUCT***

Warning



Always check for wires, fuel tanks and lines, brake lines and other important vehicle functionality items prior to drilling and installing all products.

Tools Needed

3/4" Socket and Wrench	9/16" Socket and Wrench
5/16" Allen Hex	Phillips Driver

Before You Begin

- Read all instructions.
 - Be sure to put BH-821 sealant along swage joints and all threads connecting tubes together. This is to help with water getting into the tubing and causing rust issues.
 - During installation onto vehicle, place sealant around all threads entering cargo area and between the rubber spacer and roof of vehicle to prevent water from leaking into cargo area.
-

GOOP APPLICATION

Apply a healthy air tight bead of goop around **every** swaged joint as shown, to prevent moisture from leaking into and out of the joint. If this is not done properly, the inside surface of the tubes can rust and rusty water can leak out. Maintain this joint seal throughout the life of your rack.

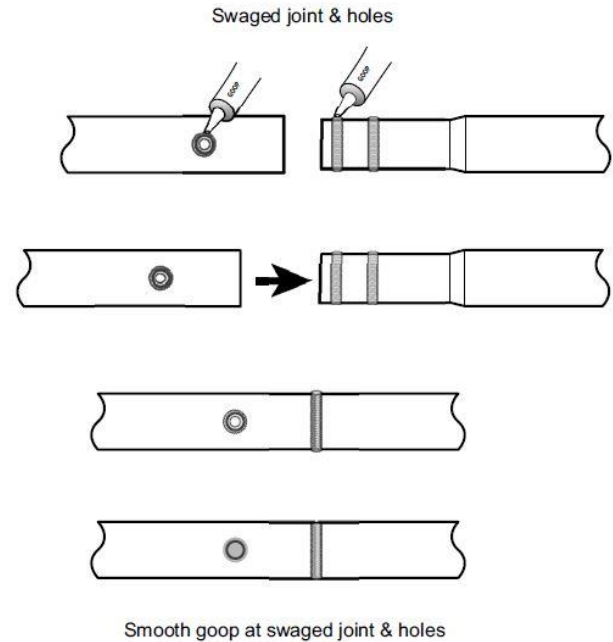



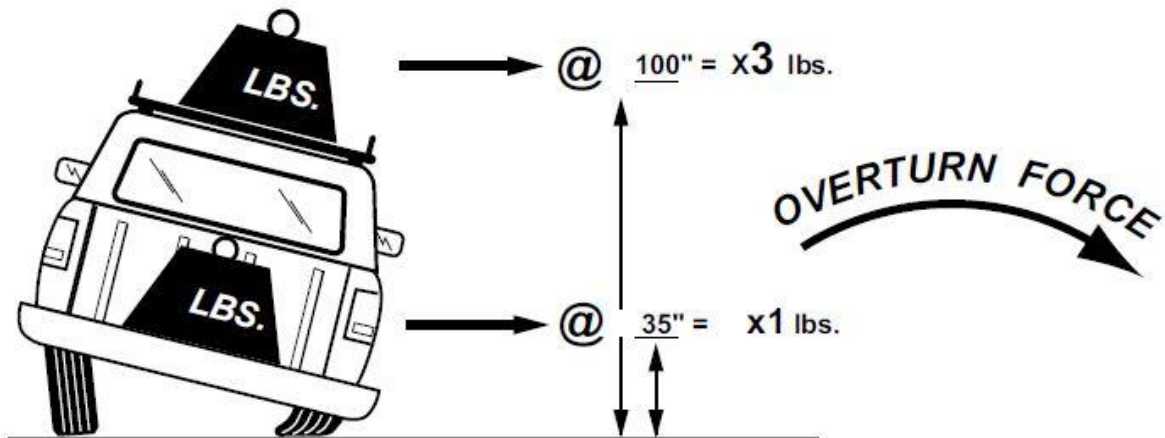

DON'T OVERLOAD YOUR VEHICLE!

TMCS_3:1



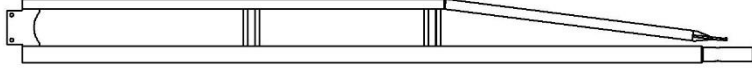
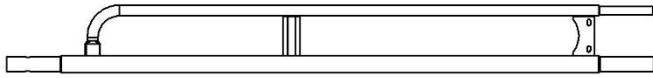
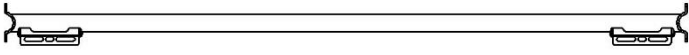
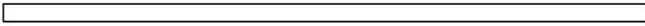

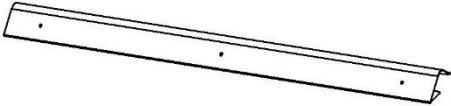
WEIGHT CARRIED ABOVE THE FLOOR OF THE TRUCK BED (E.G. ON AN OVERHEAD TRUCK RACK) WILL SIGNIFICANTLY INCREASE THE VEHICLE'S TENDENCY TO OVERTURN. ALWAYS KEEP HEAVY LOADS EVENLY DISTRIBUTED AND AS LOW AS POSSIBLE. IT IS IMPORTANT TO NOTE THAT THE KARGO MASTER RACK LOAD BEARING CAPACITY MAY BE GREATER THAN YOUR TRUCK'S GAWR OR GVWR CAPACITY, AND IS PROBABLY GREATER THAN THE WEIGHT THAT CAN BE SAFELY CARRIED OVERHEAD.

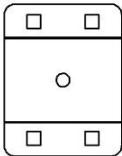
Parts

NO.		PART NUMBER	DESCRIPTION	QTY.
A		40890-00-001	FRONT HOOP	1
B		40890-04 (L/R)	FRONT, SIDE CHANNELS, ASM LEFT AND RIGHT	1L 1R
C		40890-03 (L/R)	REAR, SIDE CHANNELS, ASM LEFT AND RIGHT	1L 1R
D		40890-05	CROSS BAR ASM	3
E		40890-RB-1	REAR ROLLER BAR	1
F		40890-RB2, LEFT AND RIGHT	REAR ROLLER BAR SIDE ASM	1L 1R
G		4089A-00-023-R2	WIND DEFLECTOR	1
H		40890-00-24-C1	WIND DEFLECTOR CLAMP	3
J		11-00150	CROSS BAR CLAMP	6
		18-40890	HARDWARE KIT	1

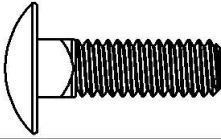
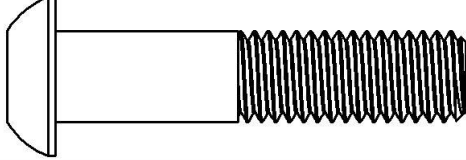
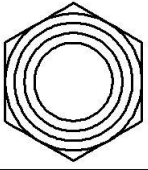
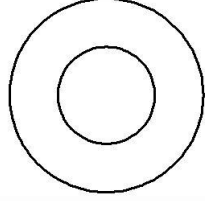
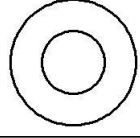
Hardware (18-40890)

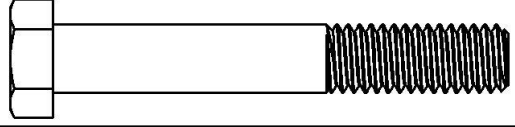
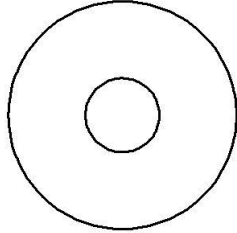
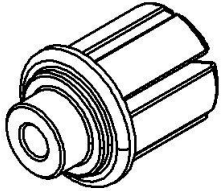
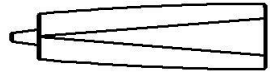
ITEM NO.	TO SCALE	PART NUMBER	DESCRIPTION	QTY.
1		90272A829	#10-32 x 1/2" Pan Head Screw	3
2		90185A583	5/16"-12 x 1" Carriage Bolt	28
3		91255A050	1/2"-13 x 2-1/4" BHCS	4
4		94945A224	1/2"-13 Jam Nyloc	4
5		90126A033	1/2" Flat Washer	4
6		90126A030	5/16" Flat Washer	28
7		95615A160	5/16"-18 Nyloc	28
8		91247A634	3/8"-16 x 2-1/2" Hex Head	2
9		91090A121	3/8" x 1-1/4" Nylon Washer	2
10		40890-06	BUSHING 1:2 SCALE	2
		BH-821	SEALANT	1

Step 1 – Determine Distance Between Feet

- On the roof of the van, determine desired mounting locations. Measure between the locations. This distance will determine the distance between the cross bar assemblies of the rack. (Transit Roof Shown)

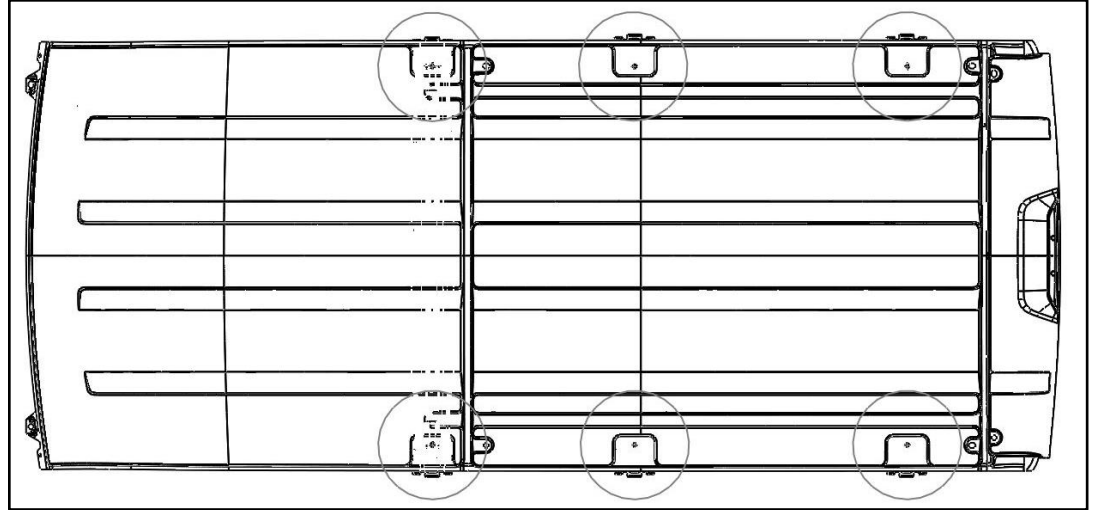

Step 2 – Assemble Side Channels

- Assemble side channels using the front side channel and the rear side channel. It does not matter which side the combination of the two will go on, just be sure to use the correct combinations. The sheet metal brackets will align properly when the correct parts are used. See picture.
- Bolt using two 5/16 carriage bolts, two 5/16 flat washers and two 5/16 nyloc nuts. Repeat for a total of two rails assemblies.

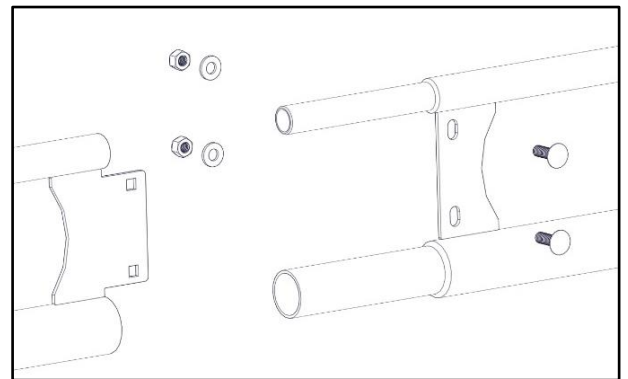

****Be sure to apply BH-821 around tube connections****

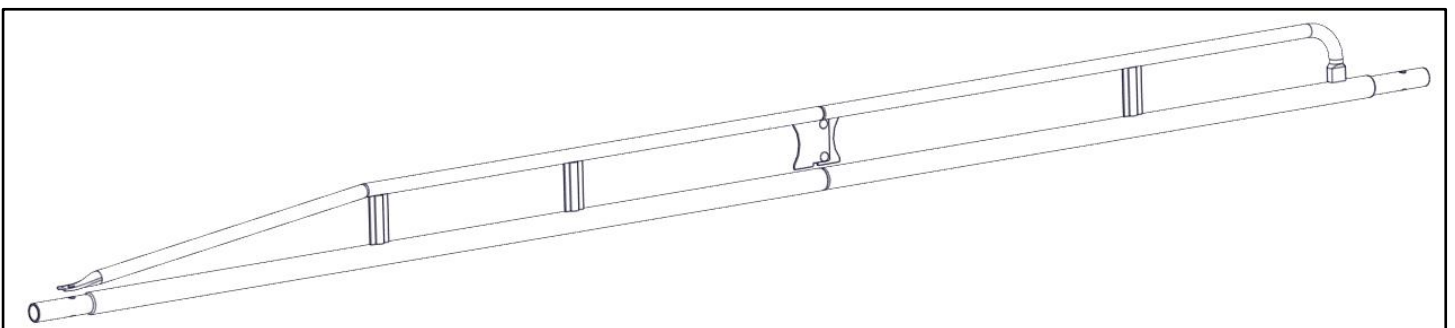
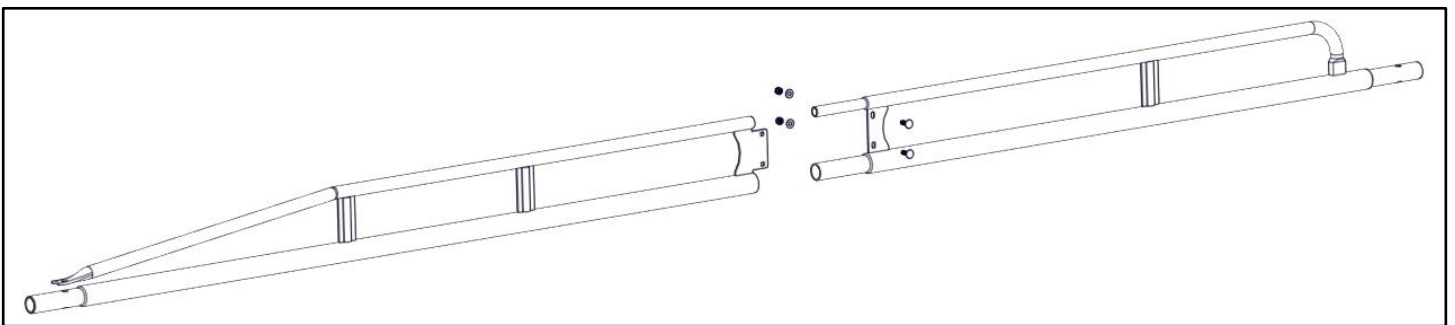

Step 3 – Assemble Rack

- Assemble the rack as shown below.
- Use the distances measured from step one to approximate where the cross bars should go.
- Do not assemble any part of the rear roller bar assembly.

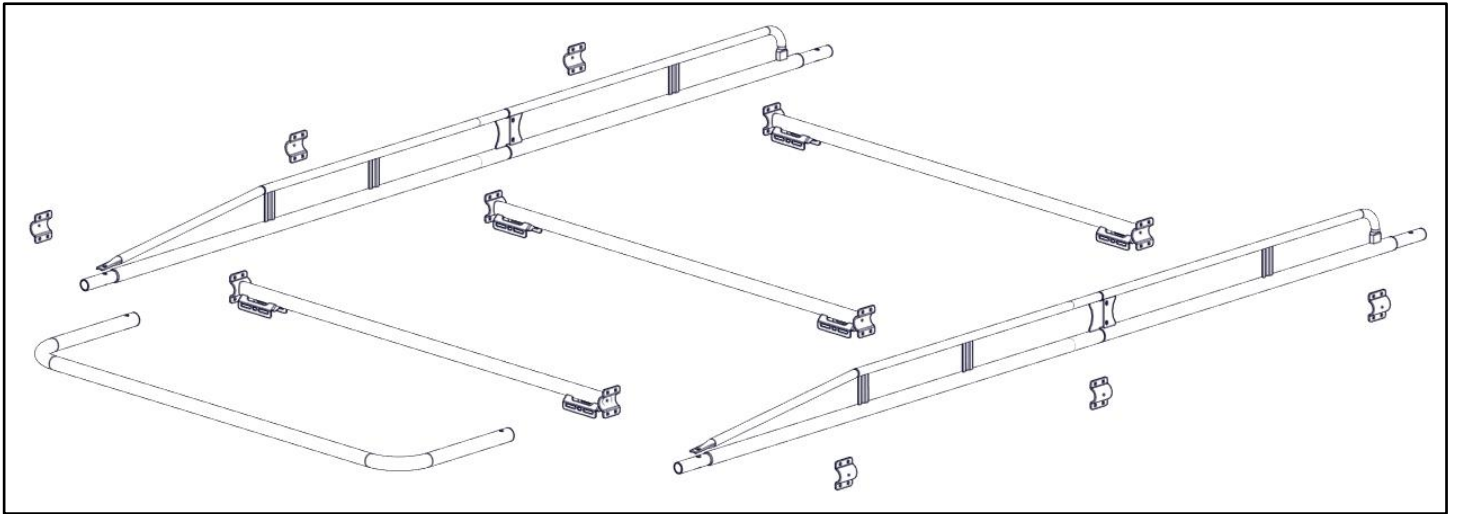

- Once crossbars are in desired position, bolt caps to crossbars using four 5/16" x 1" carriage bolts, four 5/16" flat washers and four 5/16" nyloc nuts.
- Snug Tighten, but allow movement. Adjustment will be needed when installing on vehicle.

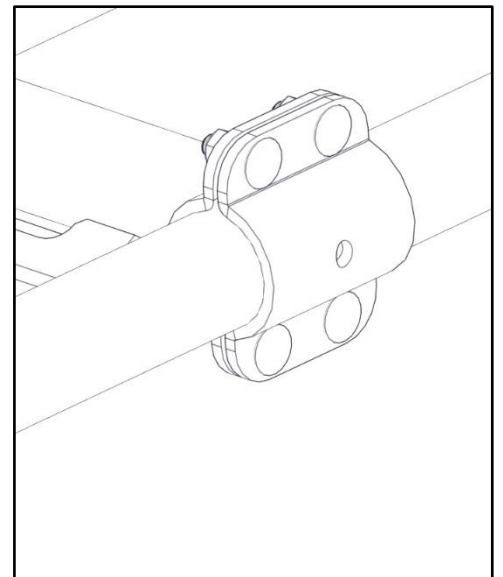
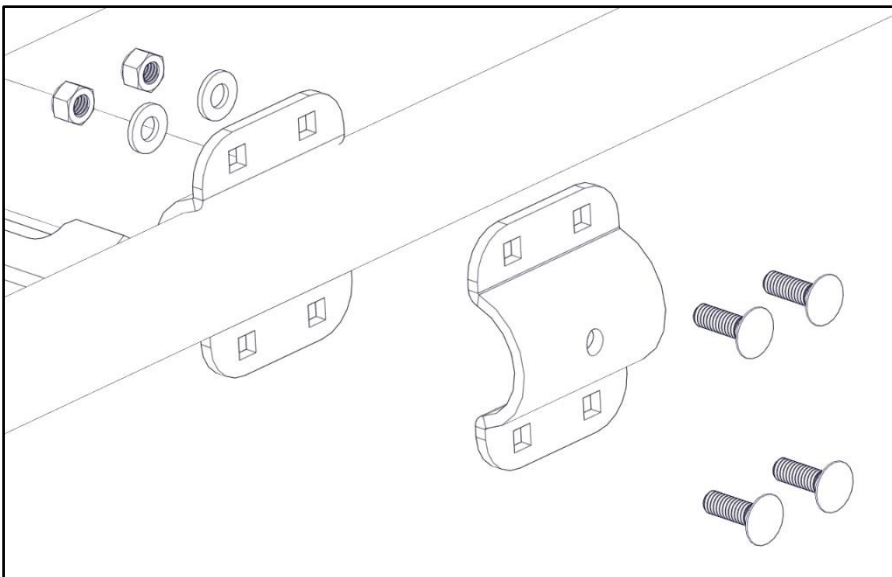

- Bolt front hoop to both side rails using 1/2" x 2-1/4" button head, 1/2" flat washer and a 1/2" nyloc nut.
- Be sure to place BH-821 along the swage joint.
- Repeat on both sides.

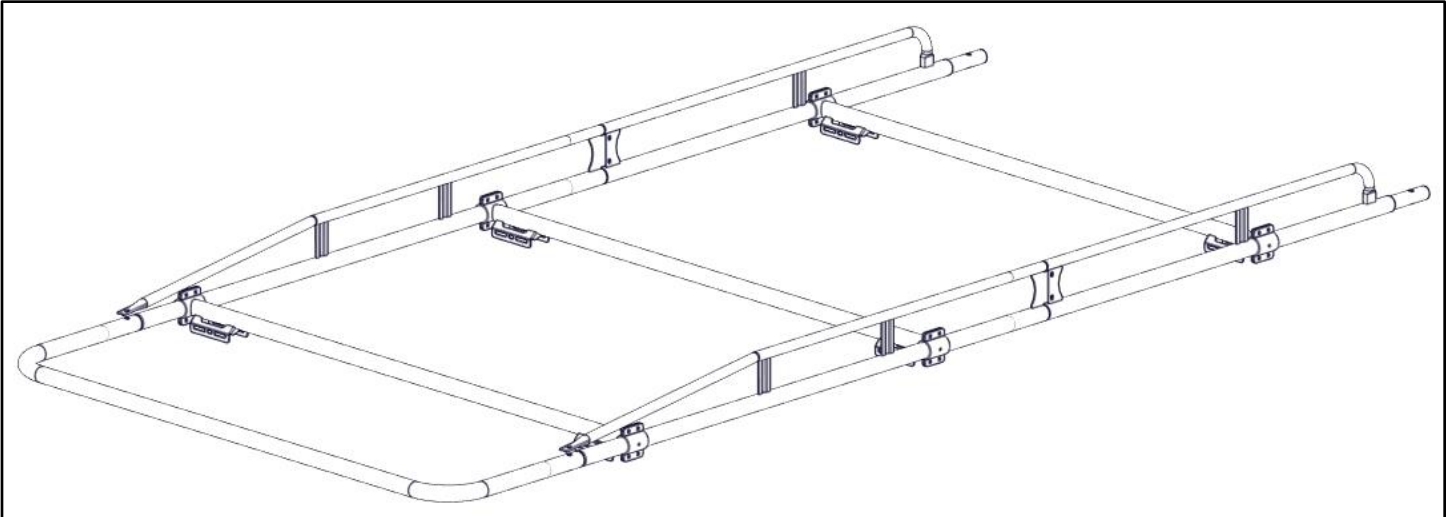
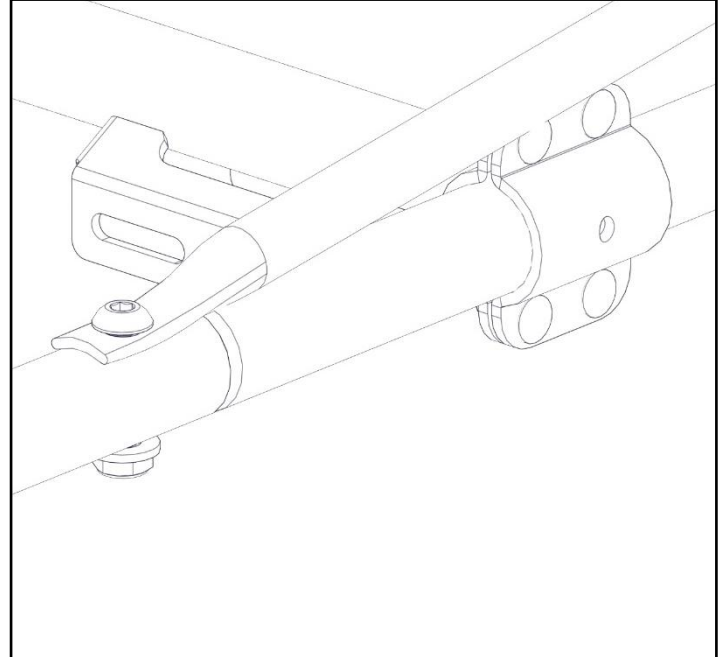
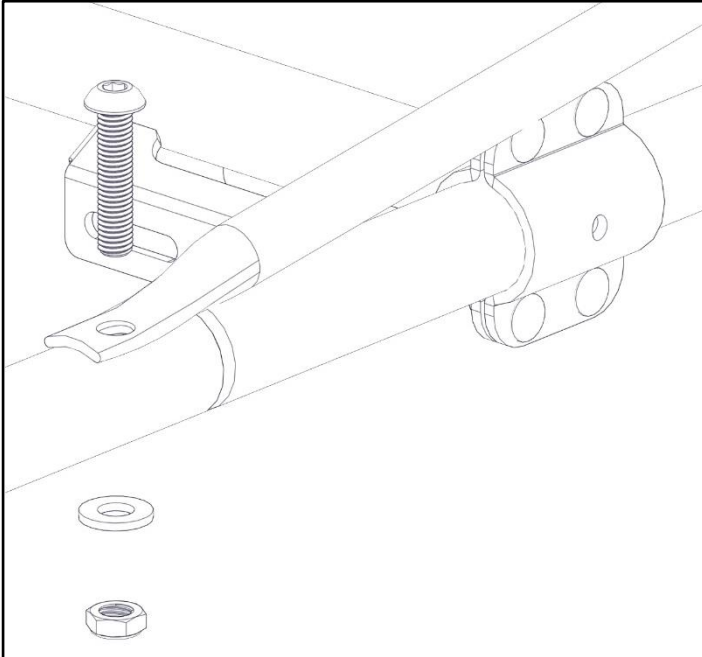

Step 4 – Assemble Rear Roller Bar

- Insert plastic bushings into the end of the roller bar as shown.
- Bolt roller bar with bushings to the roller bar side assembly using 3/8" oversize washer and 3/8" x 2-1/2" hex head bolt.
- Do not TIGHTEN.
- Bolt both roller bar side assemblies with the rear roller bar to the ends of the side channels using 1/2" x 2-1/4" button head cap screws, 1/2" flat washers and a 1/2" jam nylocs.
- Once all pieces are attached to the main assembly, one may TIGHTEN.
- Be sure to place BH-821 on all swage joints.

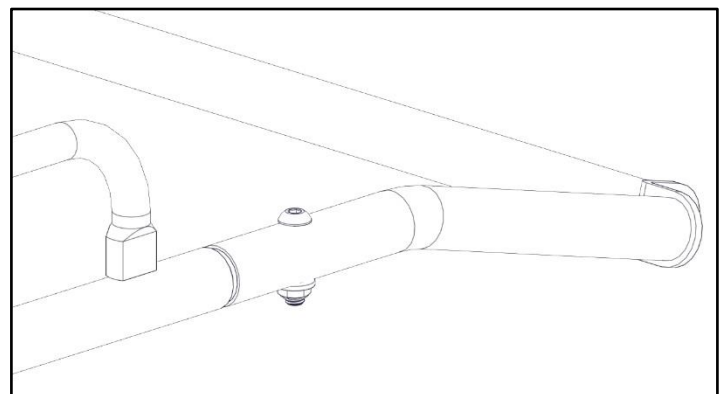
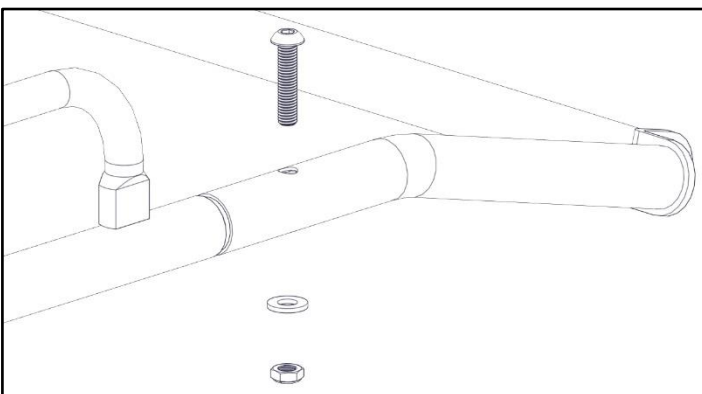
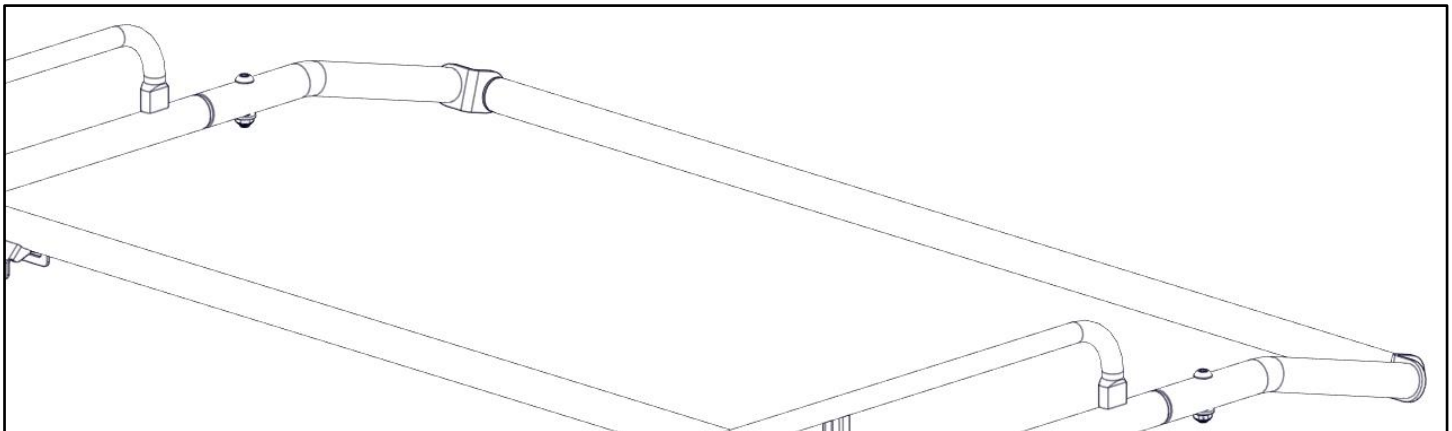
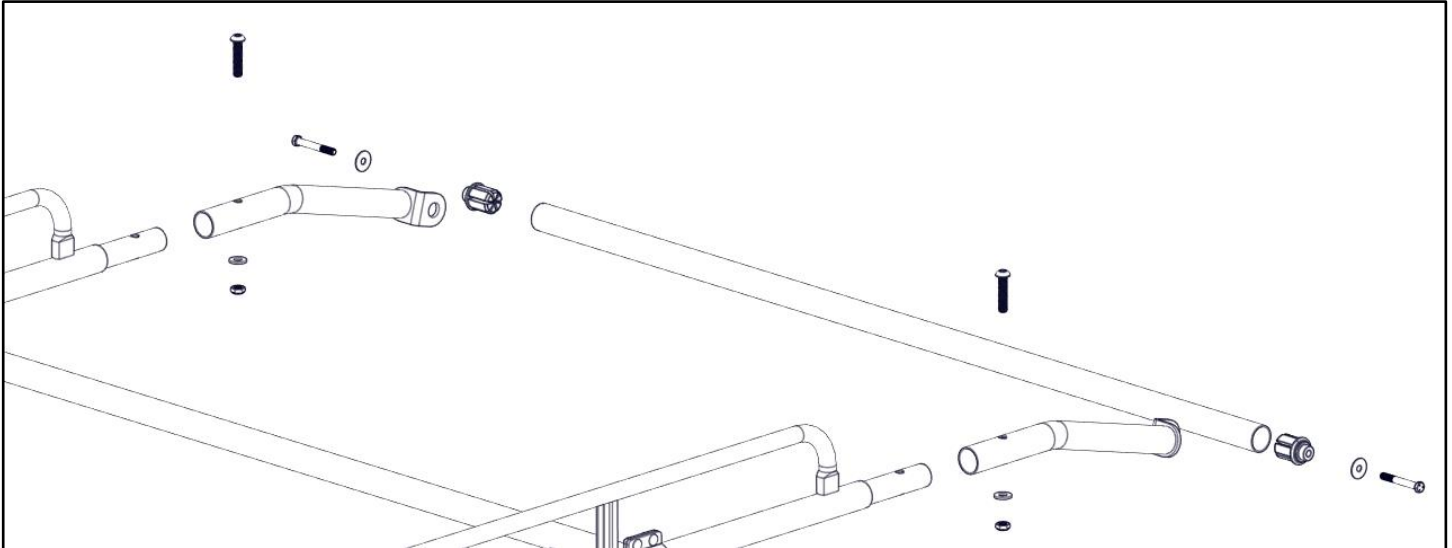

Step 5 – Install Wind Deflector

- Place wind deflector along the front hoop. Some adjustment may be needed once vehicle is driven to minimize road noise.
- Position clamp so it hooks in the slot of the wind deflector and goes around the front hoop.
- Bolt through the wind deflector and into the clamps using a #10 x 1/2" pan head screw.
- Repeat 3 times.

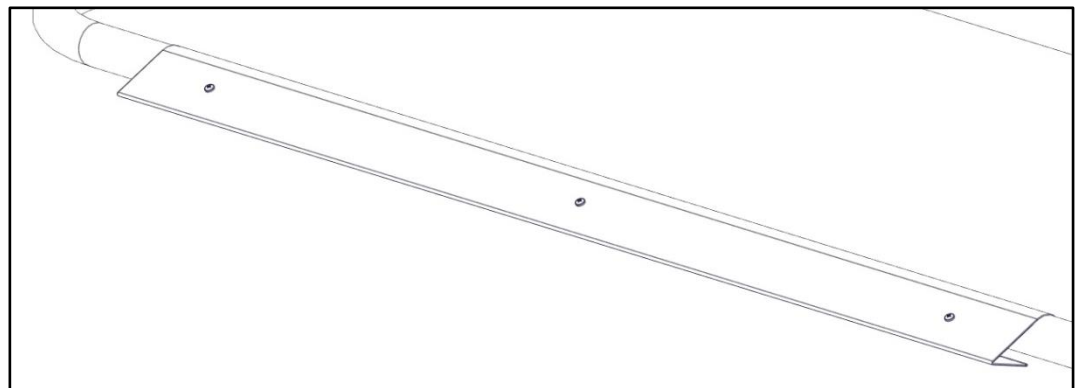
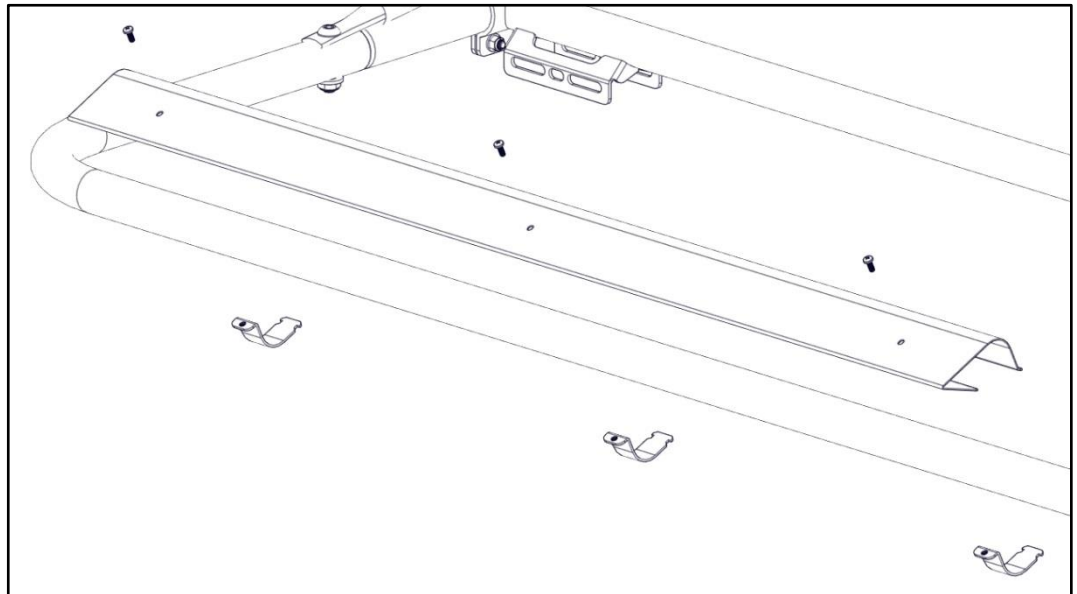
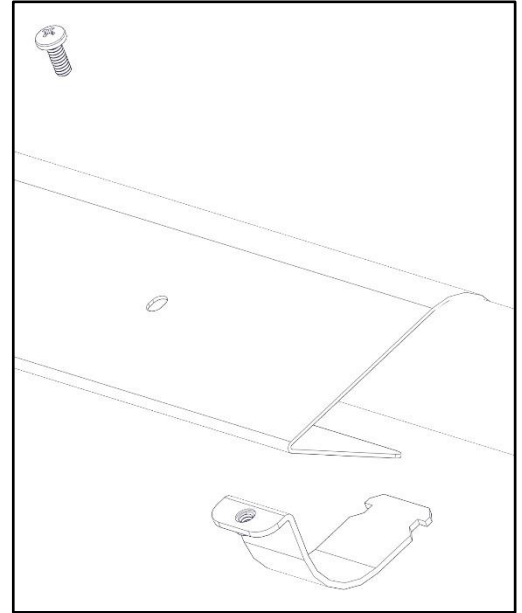
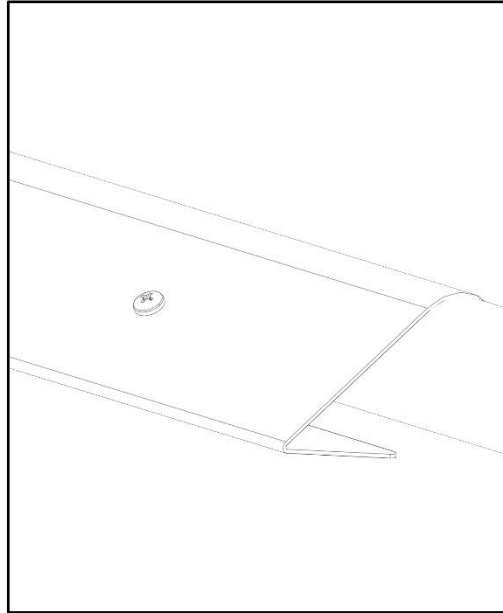

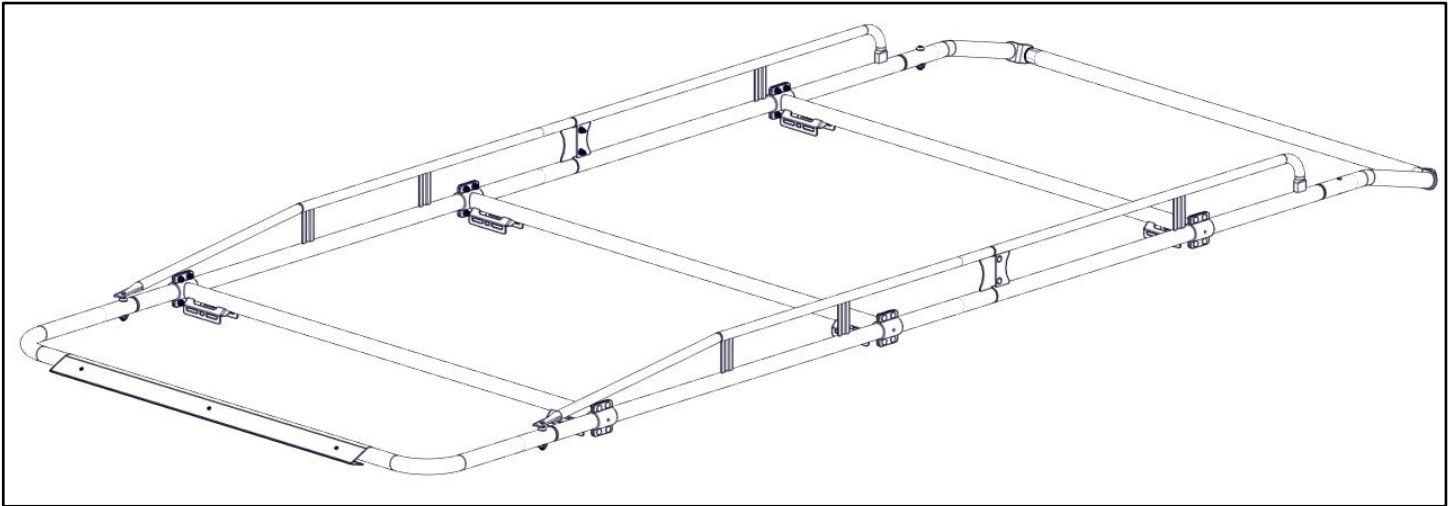

Follow the mount kit instructions in the mount kit box to finish the installation.

Some adjustment on the wind deflector may be needed after driving and evaluating the wind noise.

GO BACK AND MAKE SURE ALL HARDWARE IS TIGHT
YOUR INSTALLATION IS NOW COMPLETE