

KARGO MASTER®

WE PUT EVERYTHING WITHIN REACH.

Installation Guide

409CD

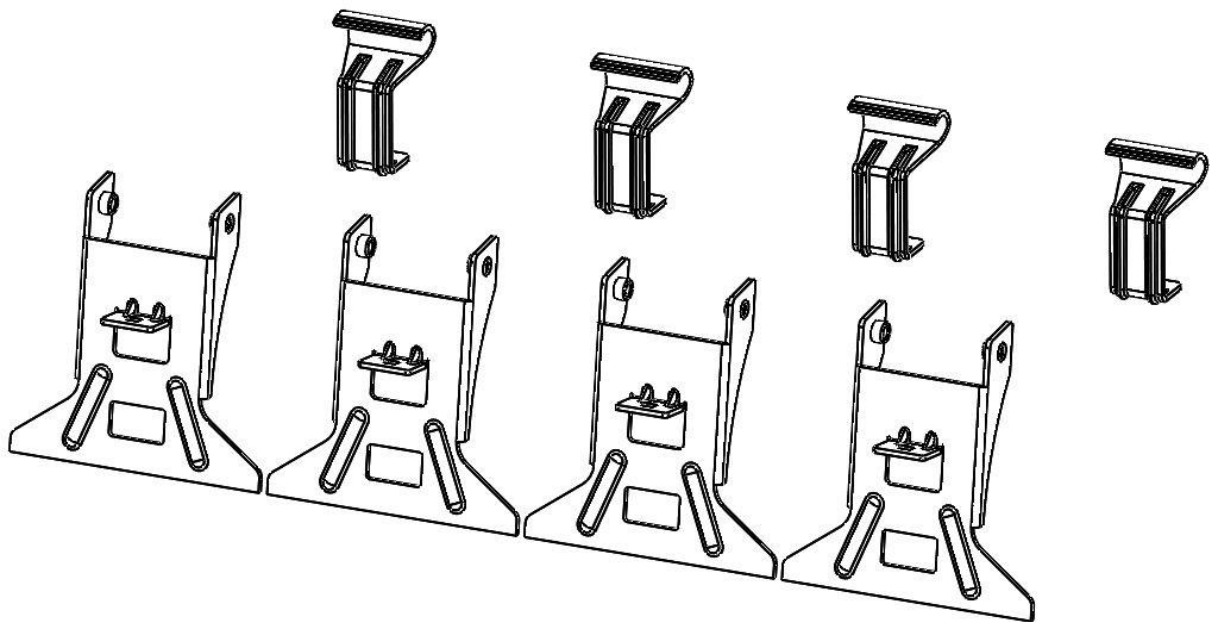

***PLEASE READ ALL INSTRUCTIONS AND WARNINGS PRIOR TO ASSEMBLING,
INSTALLING, AND USING THIS PRODUCT***

Warning



Always check for wires, fuel tanks and lines, brake lines and other important vehicle functionality items prior to drilling and installing all products.

Tools Needed

9/16" Socket and Wrench	1/2" Socket and Wrench
-------------------------	------------------------

Before You Begin

- Read all instructions.
 - Have desired ladder rack ready to be installed.
-

Parts

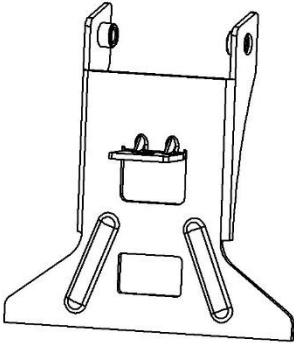
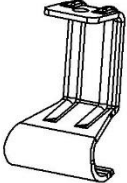
ITEM NO.		PART NUMBER	DESCRIPTION	QTY.
A		409CD-00-001	GM FOOT	4
B		40800-00-002	CLAMP BRK	4
		18-4081C	Hardware Kit	1

Hardware

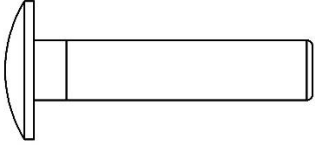
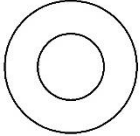
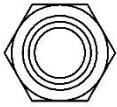
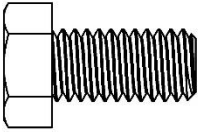
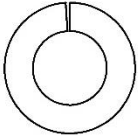
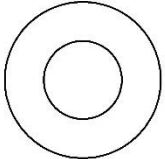
ITEM NO.	TO SCALE	PART NUMBER	DESCRIPTION	QTY.
1		90185A587	.312-18x1.5 Carriage Bolt	4
2		90126A030	5/16 Flat Washer	4
3		95615A160	5/16-18 Nyloc	4
4		92620A622	.375-16 x .75 HH	8
5		91104A031	3/8" Lock Washer	8
6		98023A031	3/8" Flat Washer	8

Step 1 – Foot Attachment

- Measure width of rain gutter on van, front and rear, typically they differ.
- Approximately at that width measured from the rain gutter, find the corresponding slots on the ladder rack cross bow and attach mounting foot as shown. Be sure there is an equal distance from the center of the cross bow to each foot.

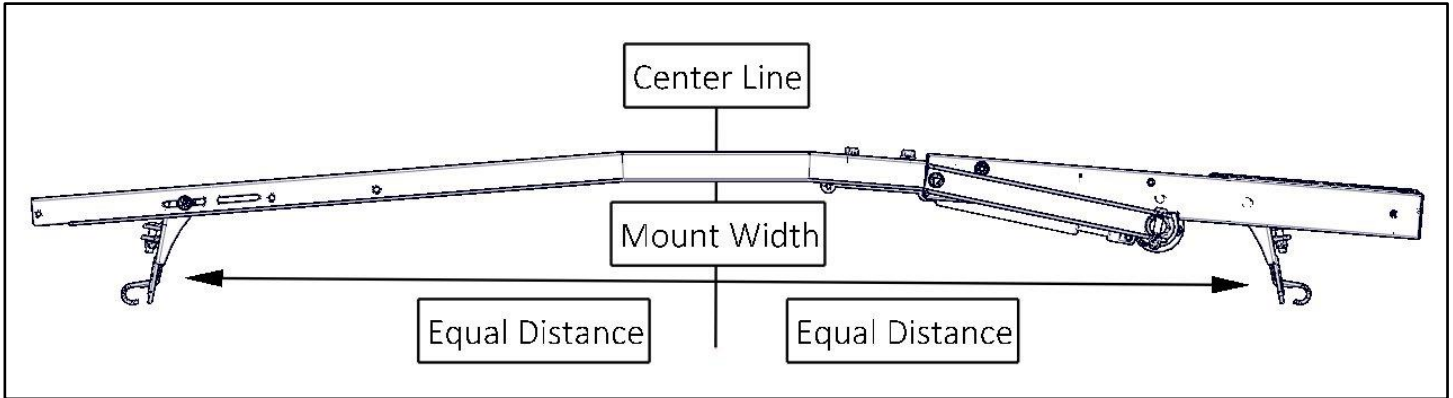

- Attach GM Foot (A) to both sides of each bow using 3/8" x 3/4" hex bolts (4) with lock washers (5) and flat washers (6) as shown.
- Leave loose until you set the assembly onto the vehicle. Most vans have a wider rain gutter at the front of the vehicle.

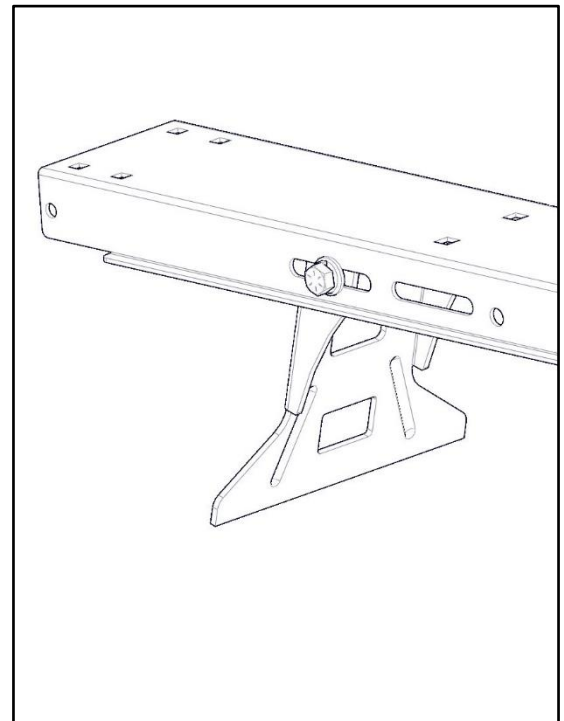
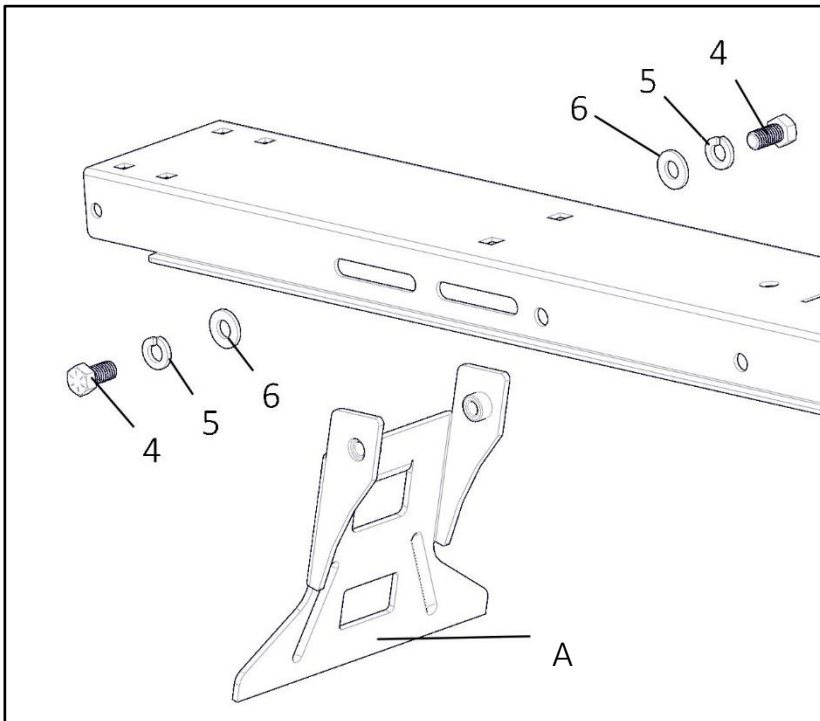

Step 2 – Attach to Rain Gutter

- Place rear bow assembly at rear of van, approximately 16" from rear of van.
- Be sure to have enough space for the handle to clear the rear of van when operating rack.

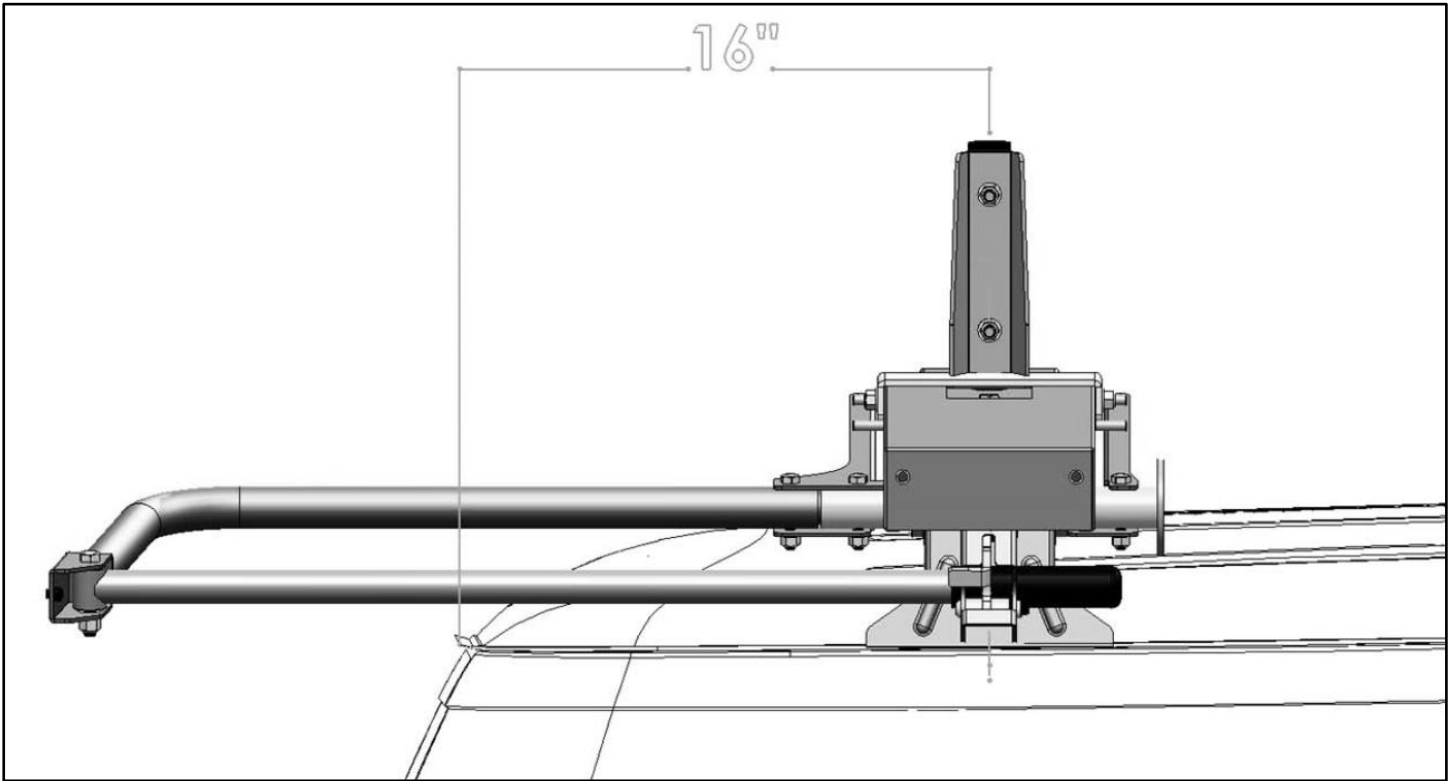

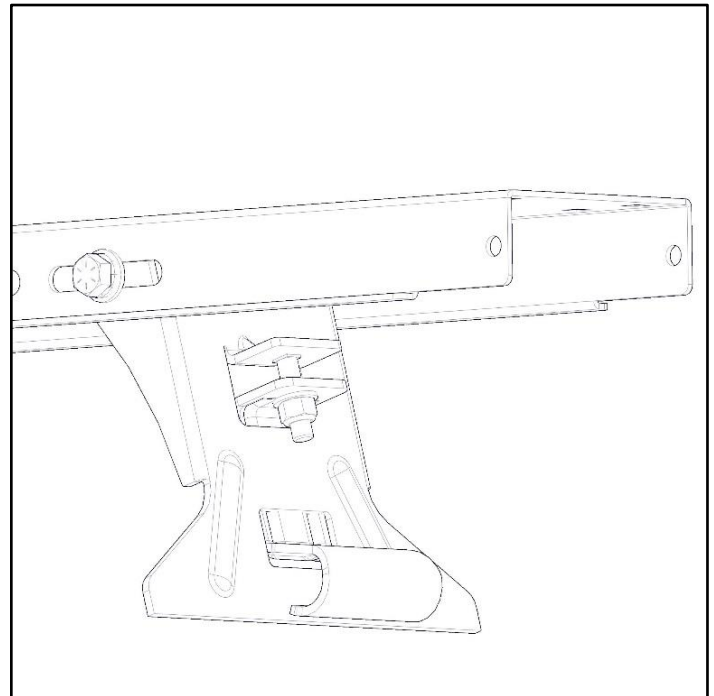
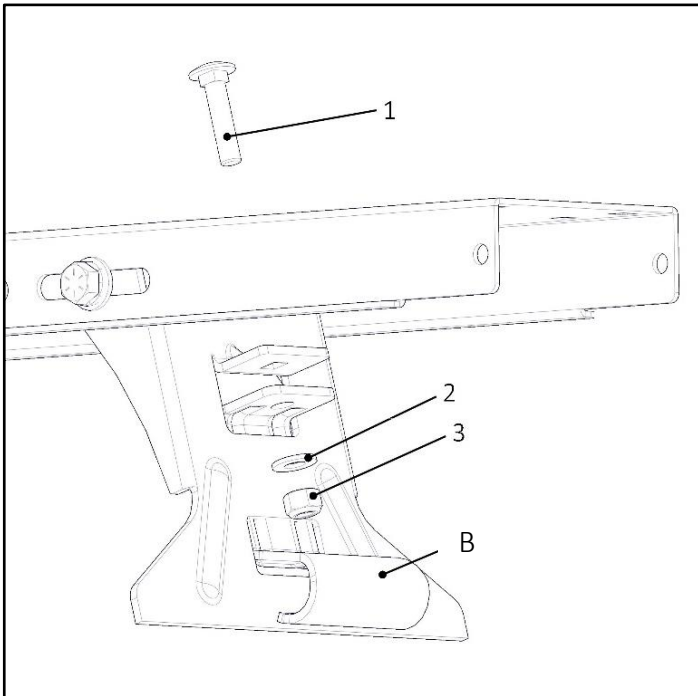

- Using a 5/16" x 1-1/2" carriage bolt (1), a 5/16" flat washer (2) and a 5/16" nyloc nut (3), insert gutter mount (B) through mount foot (A).
- Be sure the rear bow assembly is secure, but can still be moved front to rear.
- Place front bow onto roof of van.
- Assemble rack as shown in the ladder rack instructions.
- Once the ladder rack is square and aligned to the users desire, TIGHTEN.
- Repeat on all four corners of van.

Shown without van for clarity

GO BACK AND ENSURE ALL HARDWARE IS TIGHT

Your installation is now complete.

KARGO MASTER[®]

WE PUT EVERYTHING WITHIN REACH.

Installation Guide

4A95L

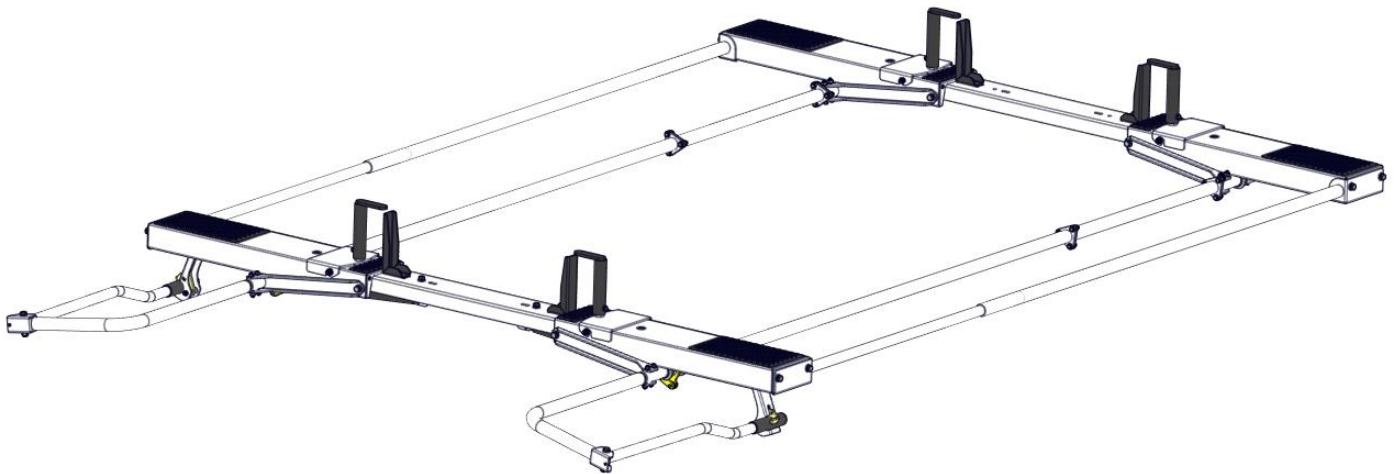

*PLEASE READ ALL INSTRUCTIONS AND WARNINGS PRIOR TO ASSEMBLING,
INSTALLING, AND USING THIS PRODUCT*

Warning



Always check for wires, fuel tanks and lines, brake lines and other important vehicle functionality items prior to drilling and installing all products.



Tools Needed

7/16" Wrench and Socket	3/8" Wrench and Socket
1/2" Wrench and Socket	9/16" Wrench and Socket
Tape Measure	





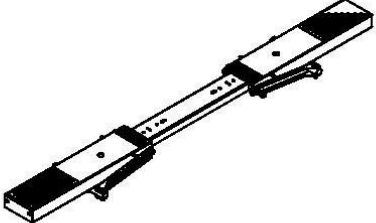
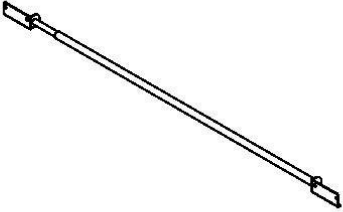
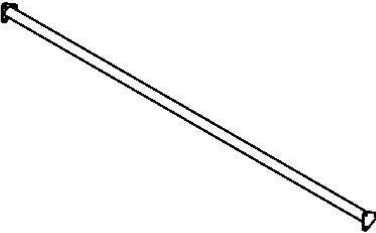

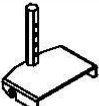
Before You Begin

- Read all instructions.
 - Have mount kit installed on vehicle.
 - NEVER EXCEED MANUFACTURERS ROOF WEIGHT RATING.
 - Place BH-821 around all tube connections to ensure water does not get inside of rack.
-

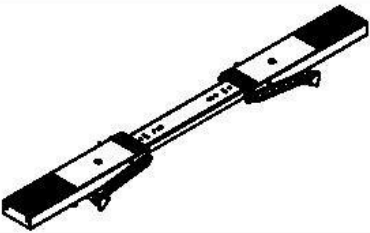
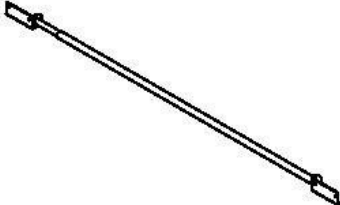
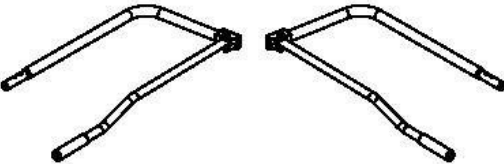

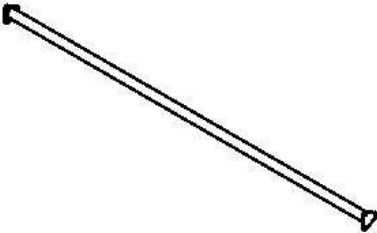

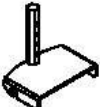

Parts

PART	PART NO.	QTY
	4A95L-2	1
	4A93L-7	1
	4A93L-50	1
	4A900-35	4
	4A900-36	2

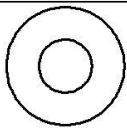
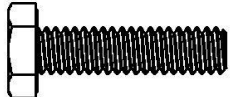
Parts Continued

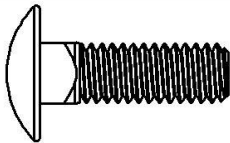
PART	PART NO.	QTY
	4A95L-1	1
	4A93L-7	1
	4A93L-70 4A93L-71	2
	4A93L-51	2
	4A93L-50	1
	4A93L-44-R1	2
	4A900-36	2
	4A900-30-004 -R3	4
	HARDWARE	1

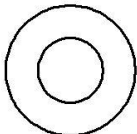
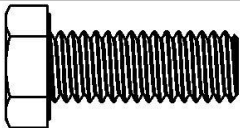
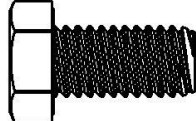
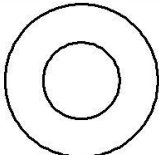
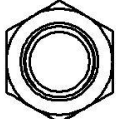
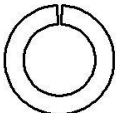
HARDWARE

ITEM NO.	TO SCALE	PART NUMBER	DESCRIPTION	QTY.
1		90126A029	WASHER, FLAT, 1/4"	40
2		92865A542	BOLT, HEX, 1/4-20 x 1"	22
3		95615A120	NUT, NYLOK, 1/4-20	18
4		90185A583	BOLT, CARRIAGE, 5/16-18 X 1	4
5		95615A160	NUT, NYLOC, 5/16-18	4
6		90126A030	WASHER, FLAT, 5/16, SAE	4
7		92865A624	BOLT, HEX, 3/8-16 X 1"	2
8		92865A622	BOLT, HEX, 3/8-16 X .75"	8
9		90126A031	WASHER, FLAT, 3/8, SAE	12
10		97135A230	NUT, HEX, NYLOK, 3/8-16	2
11		91102A760	WASHER, LOCK, 3/8	8
12		BH-821	SEALANT	1

Step 1 – Determine Bows

- Determine front and rear bow. The triangular piece should be facing each other on each bow.

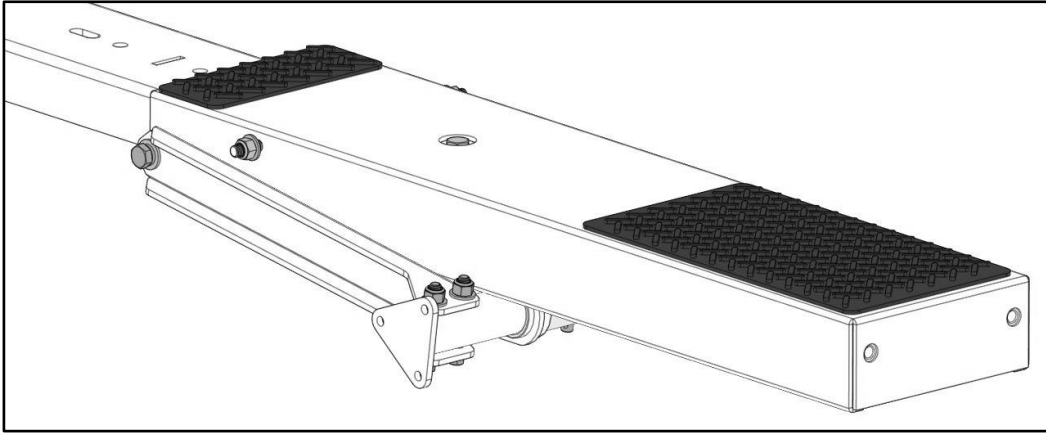

Front Bow

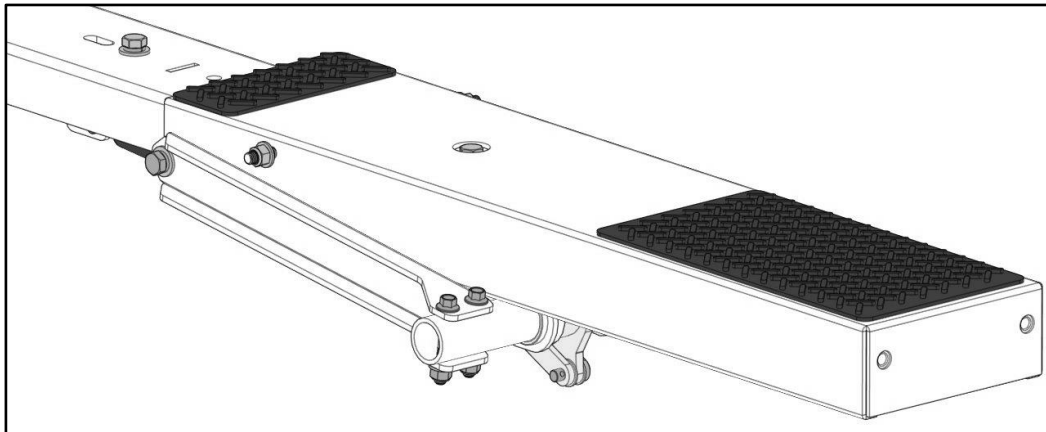

Rear Bow

Step 2 – Pan Mount

- Be sure mount kit is installed on vehicle.
- Set front and rear bow asm on mounting feet as shown.
- Place a foam block from the packaging to hold the bow in the up position in order to access the mounting slots.
- Leave loose until the the rack is assembled.
- Repeat on both ends of bow.

Feet and bow design varies from rack to rack. The installation is the same.

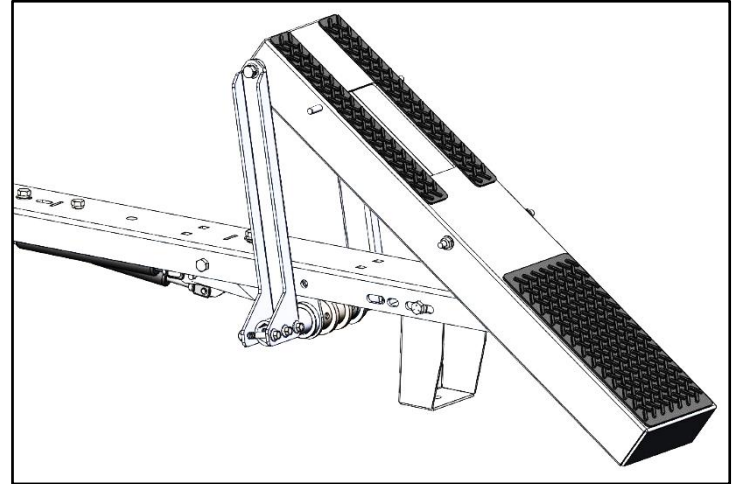
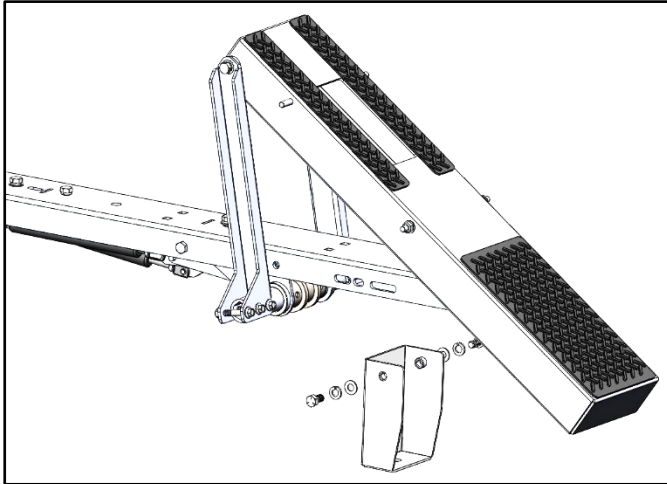

Step 3 – Determine if Extension is Needed

- Measure between the two bows as shown. If distance is approximately 84.5", the extension will be needed.
- If the distance between the two bows is approximately 60", the EXT piece is **not** needed.

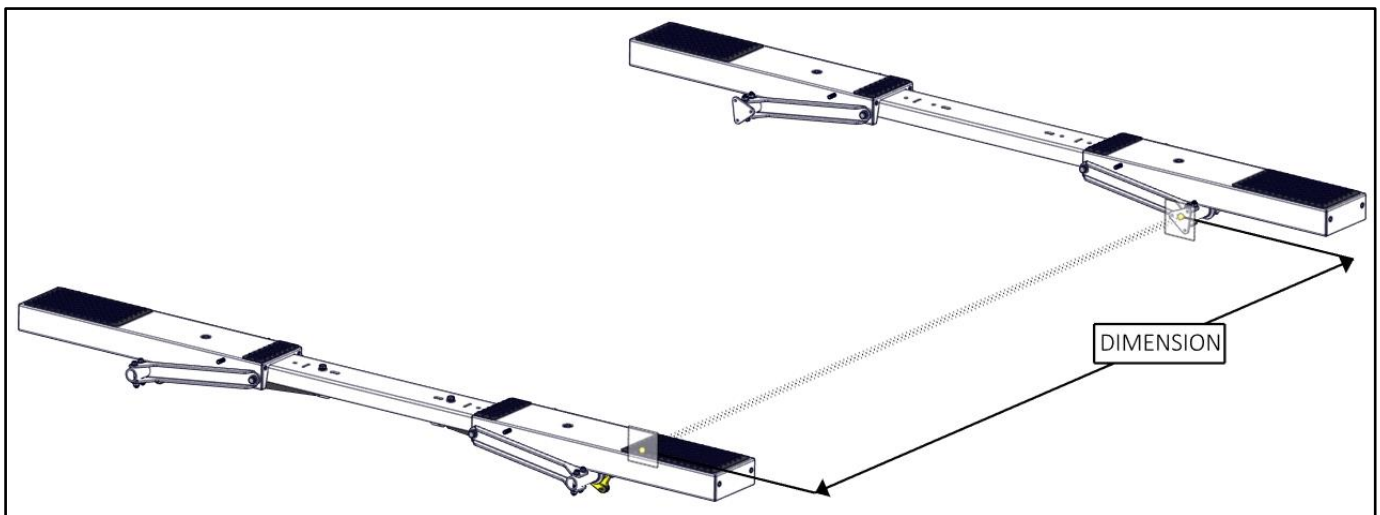

Step 4 – Install Torque Tube

- If EXT is needed, Assemble EXT to long torque tube.

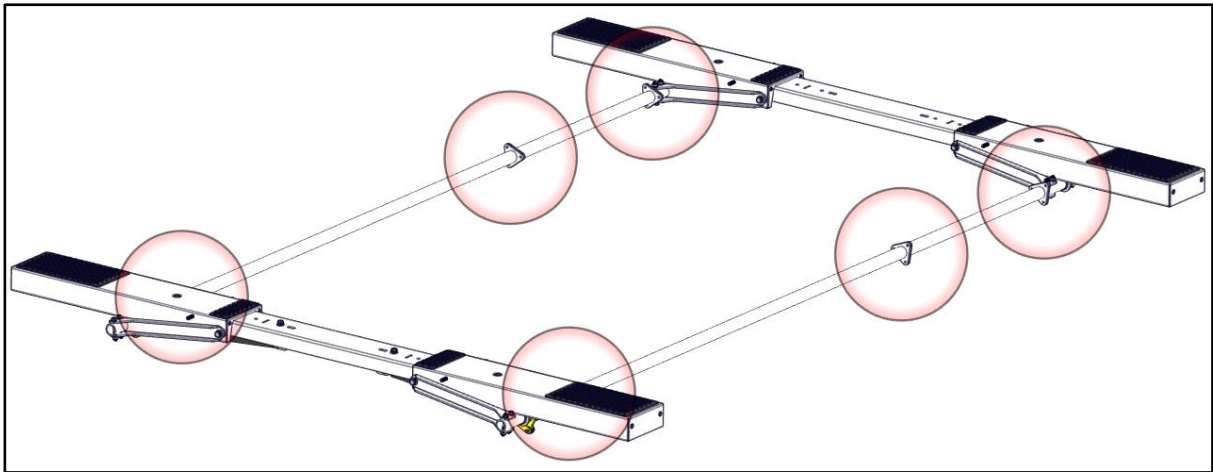

- If EXT is not needed, Only use long torque tube.

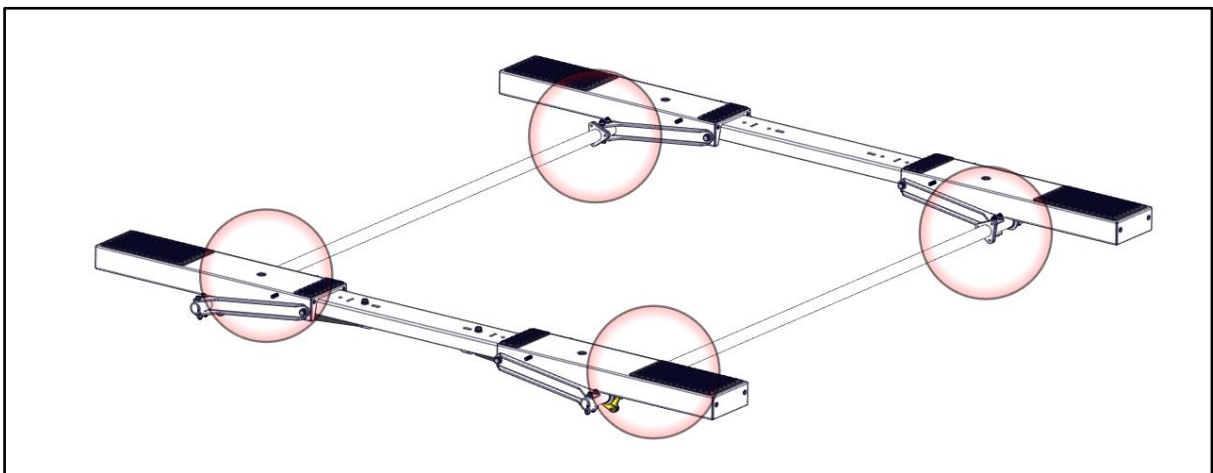

- Bolt torque tube to front and rear bow using 1/4"-20 x 1" Hex Head bolt, two 1/4" flat washers and 1/4"-20 nyloc nut at each location.

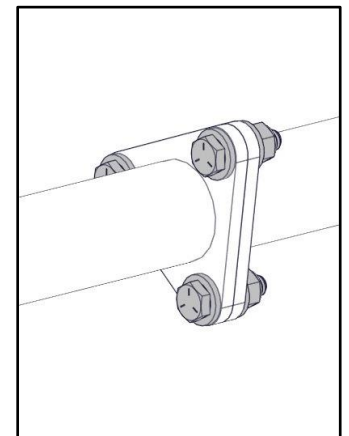
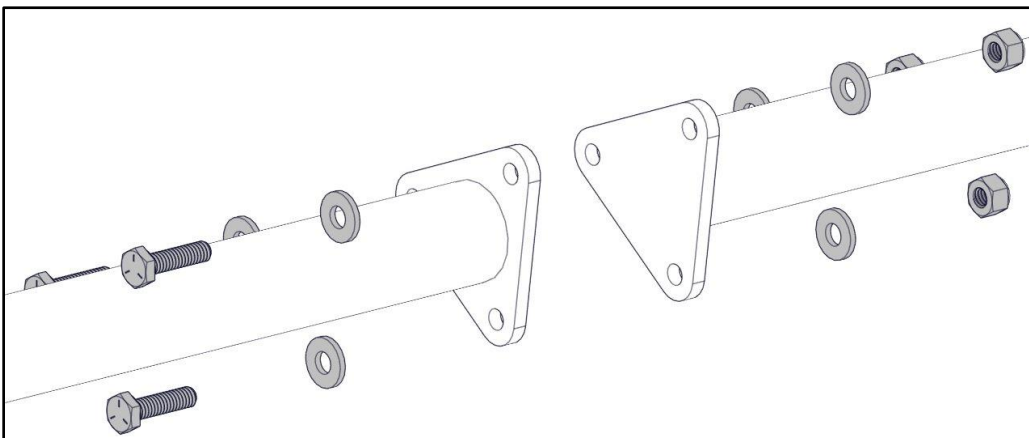

Step 5 – Install Cross Tube

- Insert crosstube as shown. Bolt to the end of both pans using 3/8" x 3/4" Hex Head bolts, 3/8" flat washers and 3/8" nyloc nuts.
- Repeat at front and rear on the ends of both bows.
- BE SURE TO USE THE 3/4" long bolts.

TIGHTEN

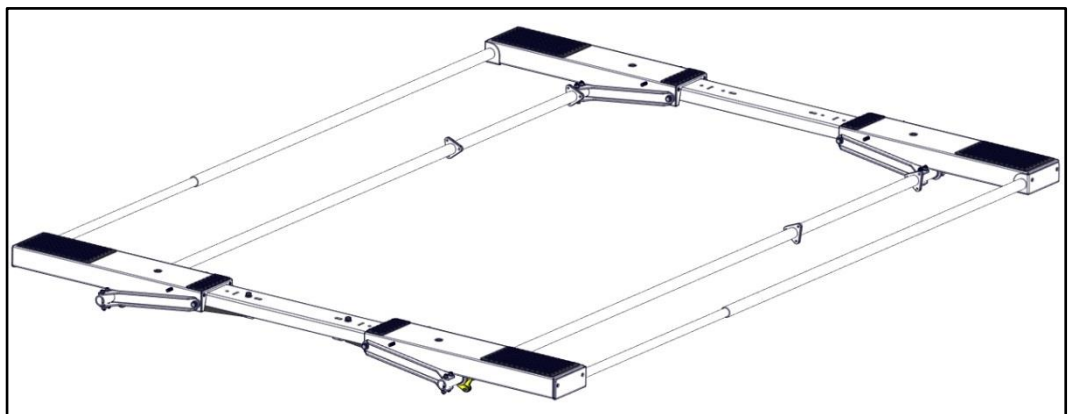
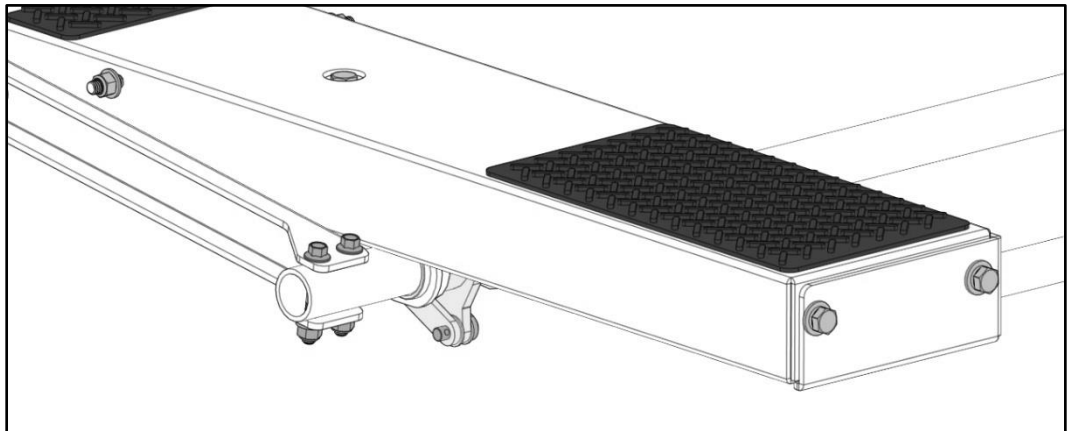
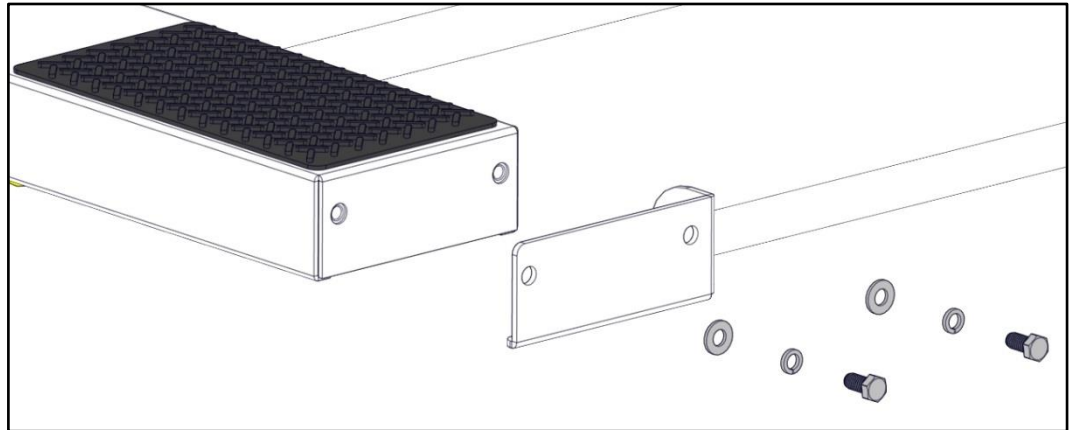
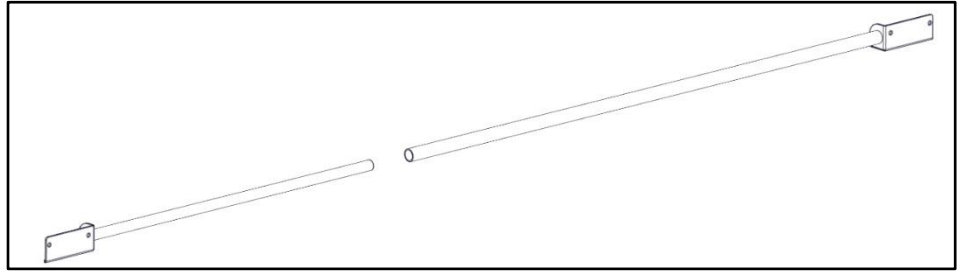

Step 6 – Install Latch

- Move rear pan assembly out of the way to expose the end of the crossmember.
- Bolt latch assembly to end of crossmember using 5/16" x 1" carriage bolts, 5/16" flat washers and 5/16" nyloc nuts.
- Shown without pan for clarity.
- Repeat on both ends of rear bow.
- TIGHTEN

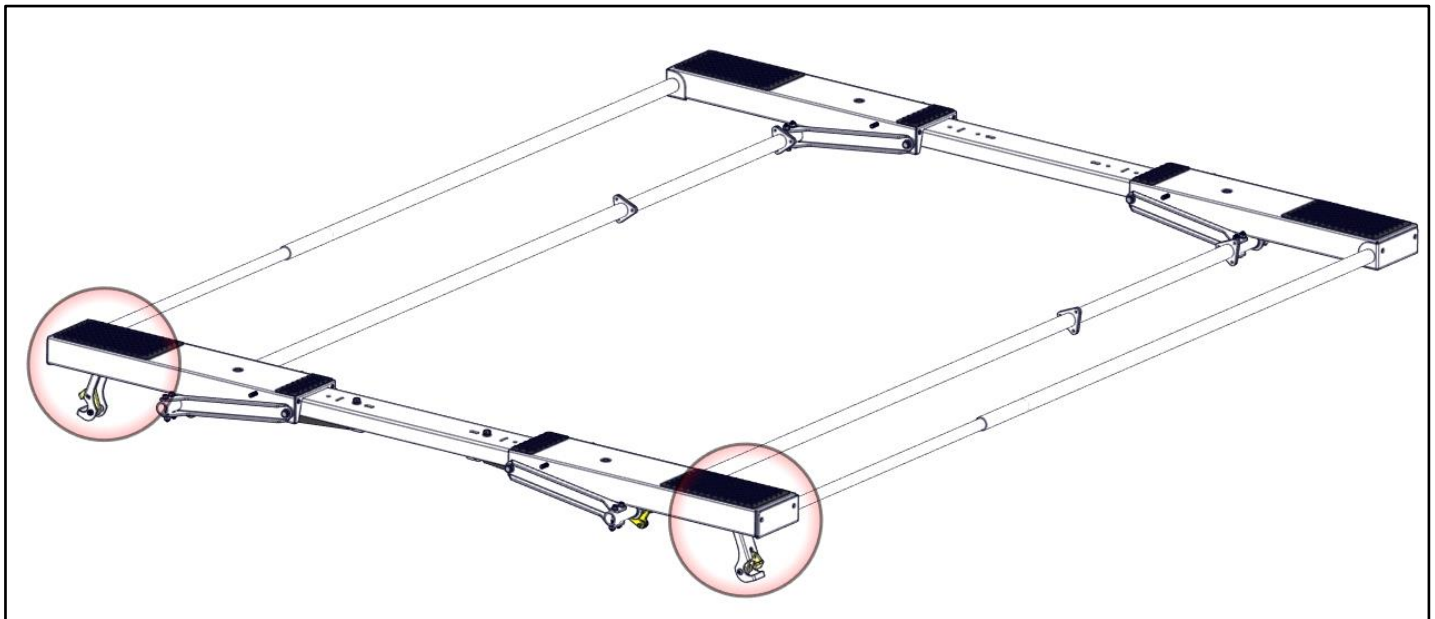
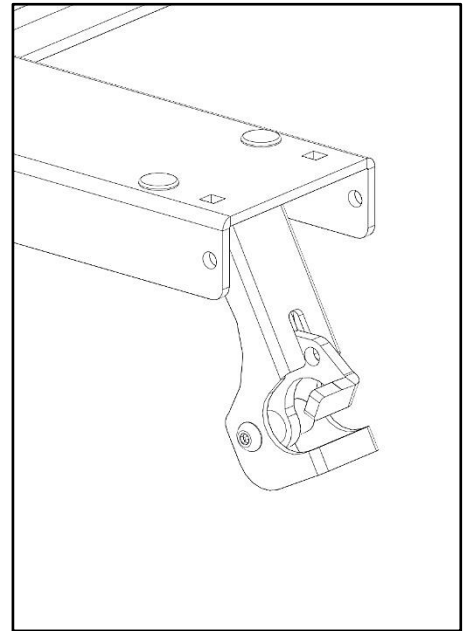
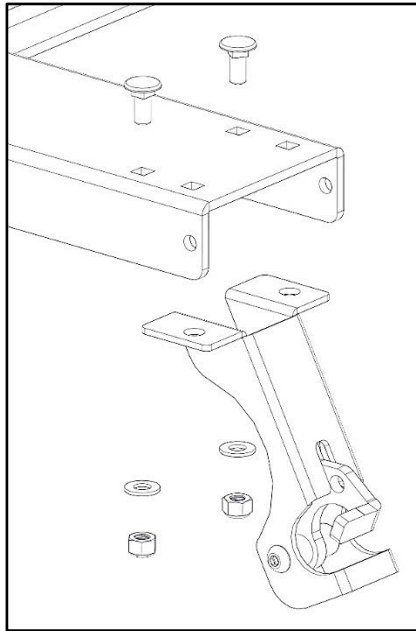

Step 7 – Install Handle

- Place handle in orientation shown. Attach handle to the rear pan using existing 5/16" hardware.
- Repeat at both ends of rear bow.
- Place BH-821 around tube connection.
- TIGHTEN

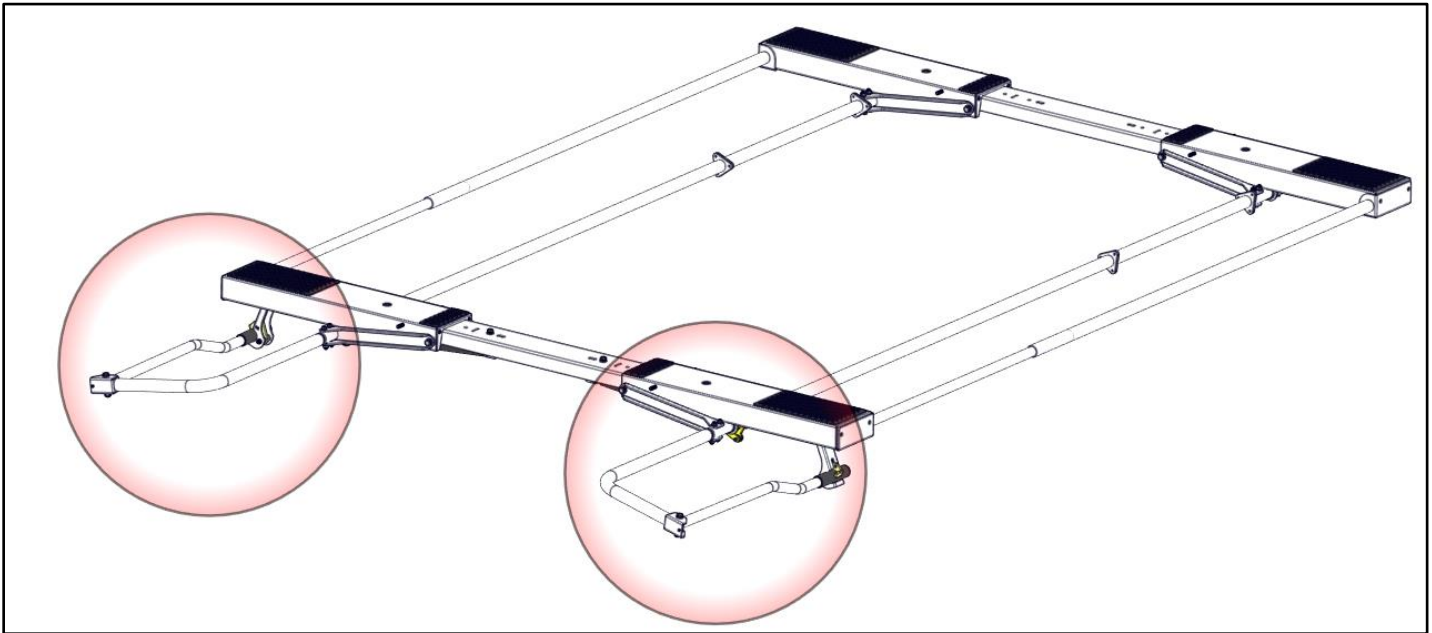
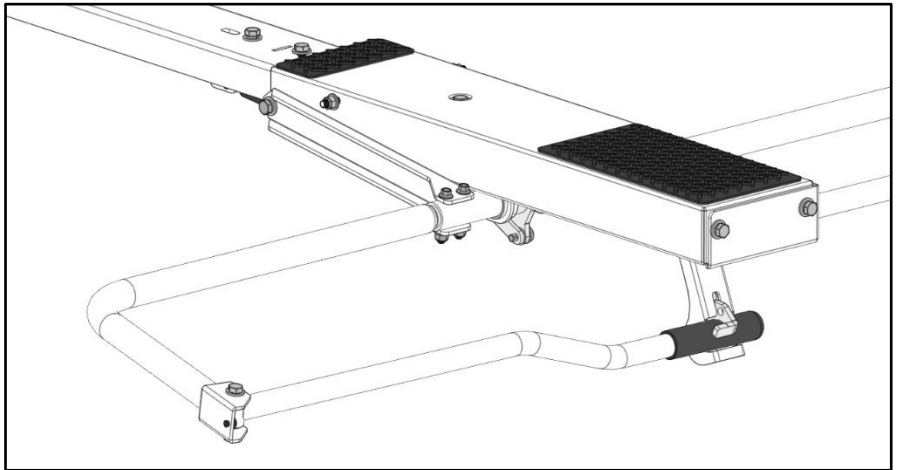
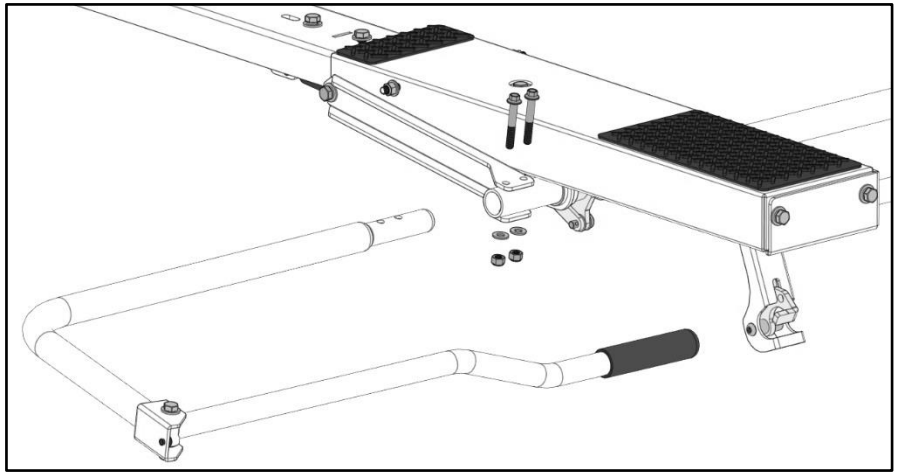

Step 8 – Ladder Stop

- Attach ladder stop to both front and rear bow. Be sure the flange of the ladder stop is aligned with the cut out in the bows.
- In the front bow, bolt in place using 3/8" x 1" hex head bolt, two 3/8" flat washers and a 3/8" nyloc nut.

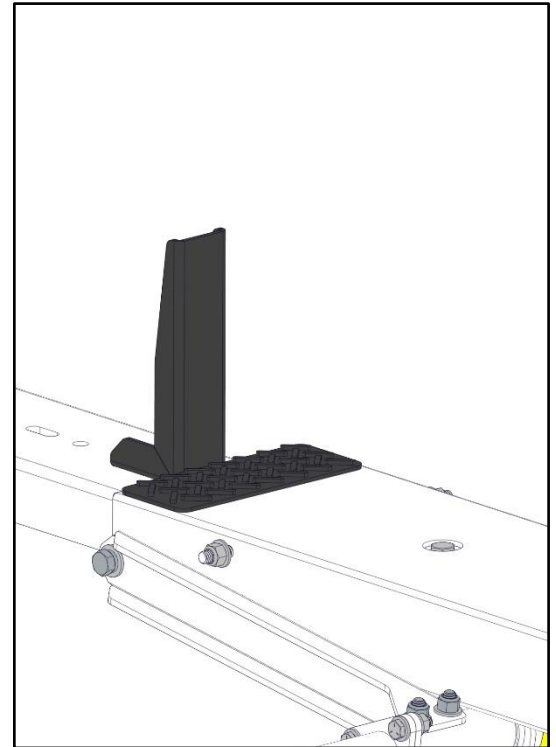
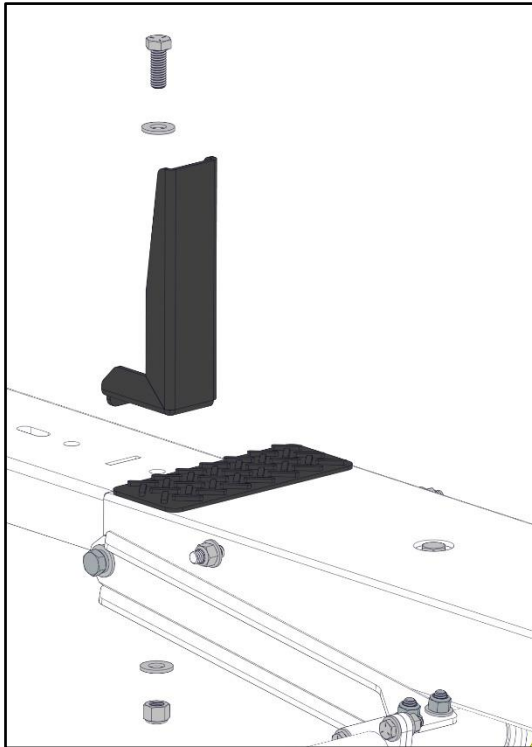

- In the rear bow, bolt in place using 3/8" x 1" hex head bolt and a 3/8" flat washer.

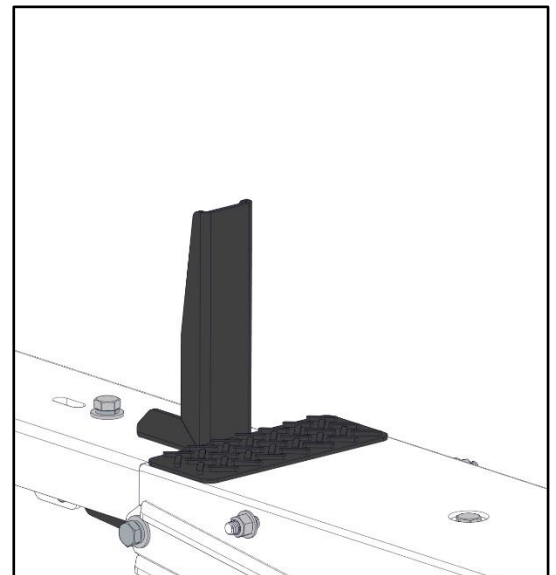
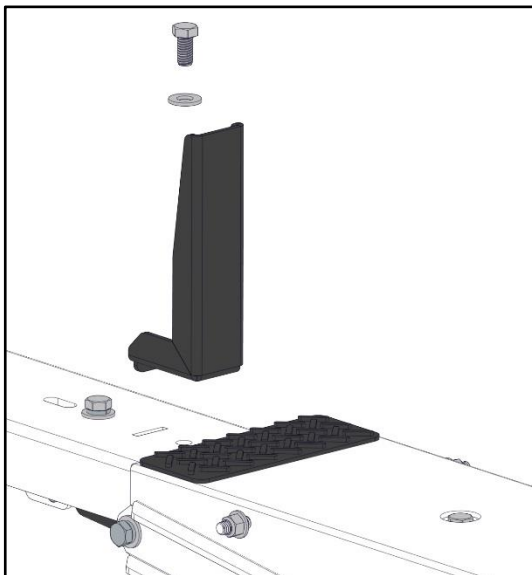

****Be sure to use the longer of the 3/8" hex head bolts****

- Repeat at both sides of each bow.
- TIGHTEN

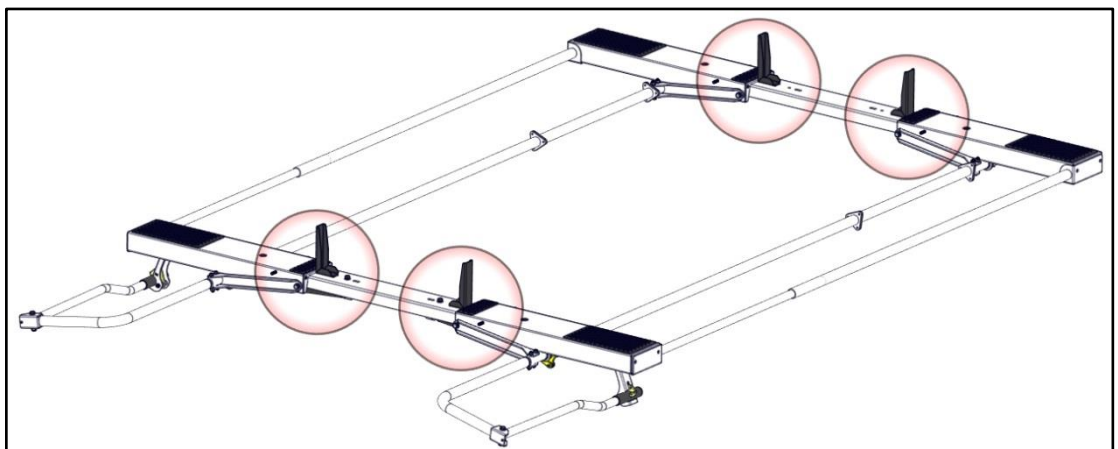

Step 9 – Assemble Ladder Hooks

- Bolt ladder hook ASM to ladder hook weldment as shown.
- Use 1/4" x 1" hex head and 1/4" flat washer. This can be adjusted later.
- TIGHTEN

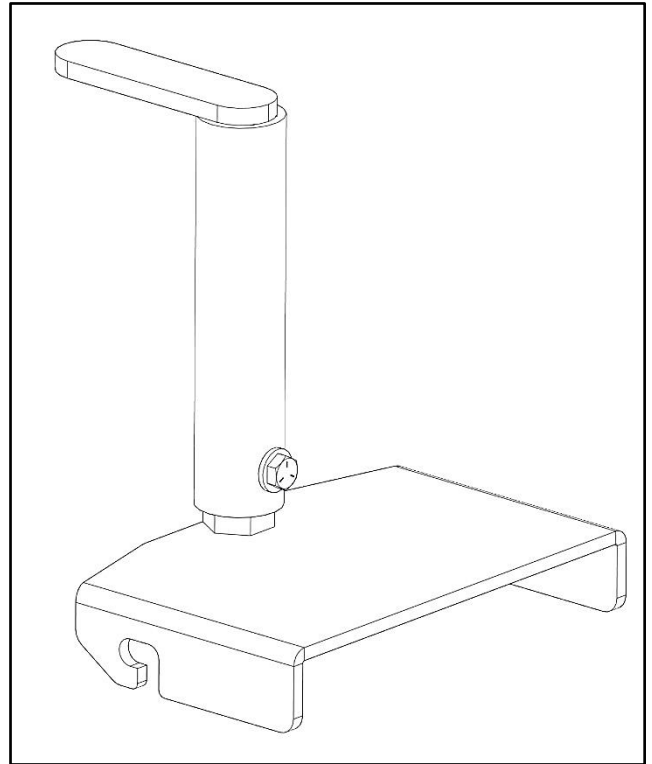
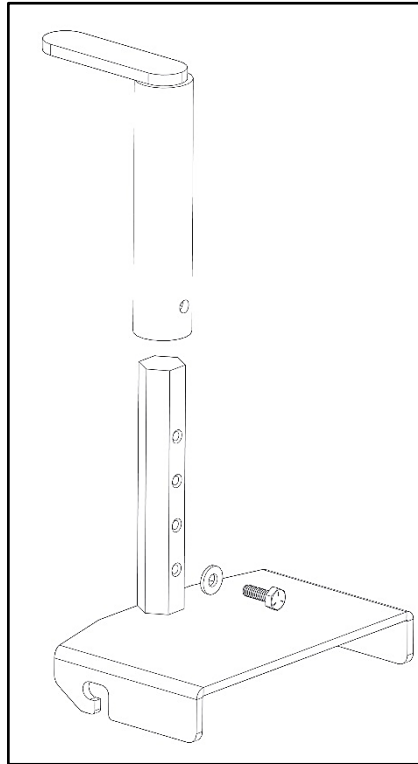

Step 10 – Install Ladder Hooks

- Using the hardware and installed pem studs on both bows, loosen nuts and slide ladder hook assembly into place.
- TIGHTEN

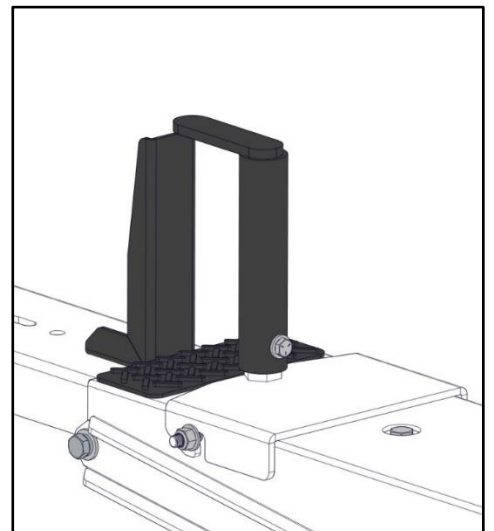
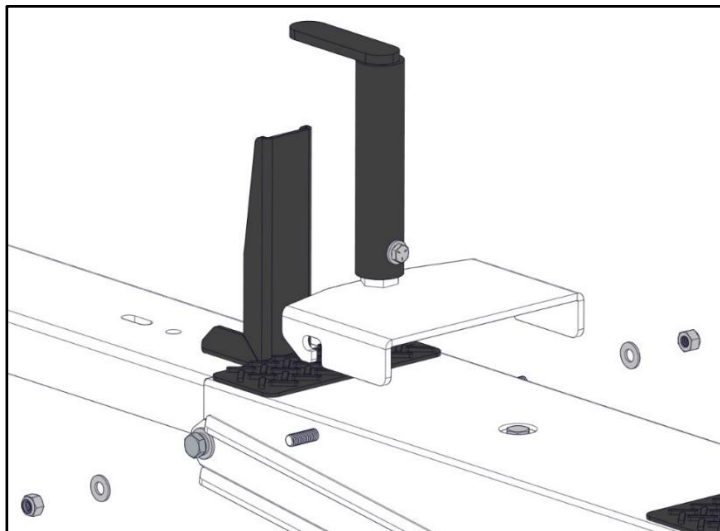
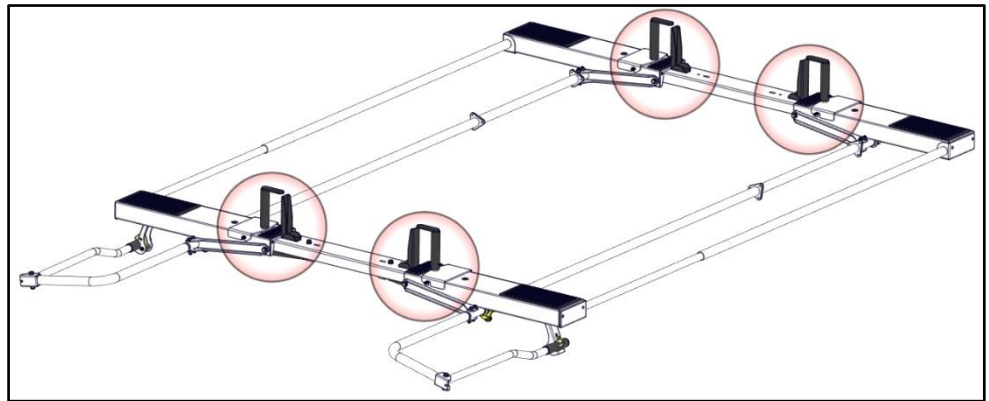

GO BACK AND TIGHTEN ALL BOLTS FROM PREVIOUS STEPS, BE SURE
HARDWARE IN MOUNTING IS TIGHT.

YOUR INSTALLATION IS NOW COMPLETE

