

KARGO MASTER®

WE PUT EVERYTHING WITHIN REACH.

Installation Guide

409CD

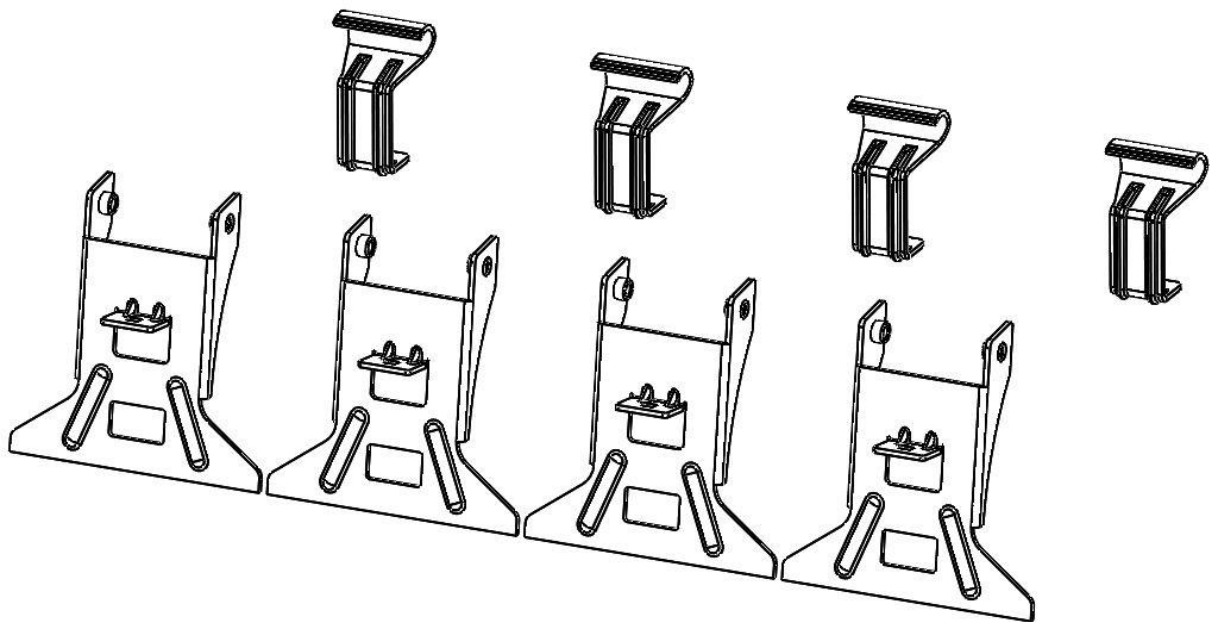

***PLEASE READ ALL INSTRUCTIONS AND WARNINGS PRIOR TO ASSEMBLING,
INSTALLING, AND USING THIS PRODUCT***

Warning



Always check for wires, fuel tanks and lines, brake lines and other important vehicle functionality items prior to drilling and installing all products.

Tools Needed

9/16" Socket and Wrench	1/2" Socket and Wrench
-------------------------	------------------------

Before You Begin

- Read all instructions.
 - Have desired ladder rack ready to be installed.
-

Parts

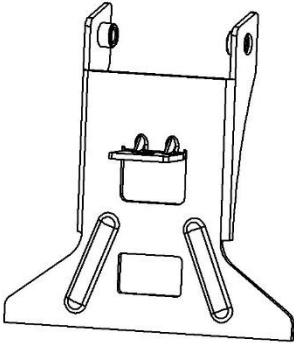
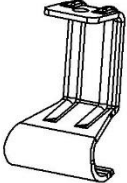
ITEM NO.		PART NUMBER	DESCRIPTION	QTY.
A		409CD-00-001	GM FOOT	4
B		40800-00-002	CLAMP BRK	4
		18-4081C	Hardware Kit	1

Hardware

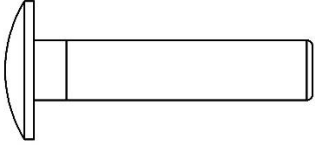
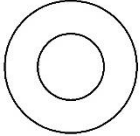
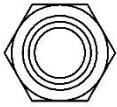
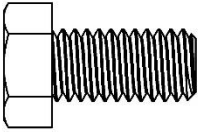
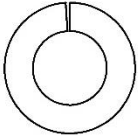
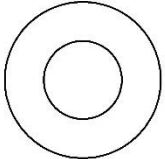
ITEM NO.	TO SCALE	PART NUMBER	DESCRIPTION	QTY.
1		90185A587	.312-18x1.5 Carriage Bolt	4
2		90126A030	5/16 Flat Washer	4
3		95615A160	5/16-18 Nyloc	4
4		92620A622	.375-16 x .75 HH	8
5		91104A031	3/8" Lock Washer	8
6		98023A031	3/8" Flat Washer	8

Step 1 – Foot Attachment

- Measure width of rain gutter on van, front and rear, typically they differ.
- Approximately at that width measured from the rain gutter, find the corresponding slots on the ladder rack cross bow and attach mounting foot as shown. Be sure there is an equal distance from the center of the cross bow to each foot.

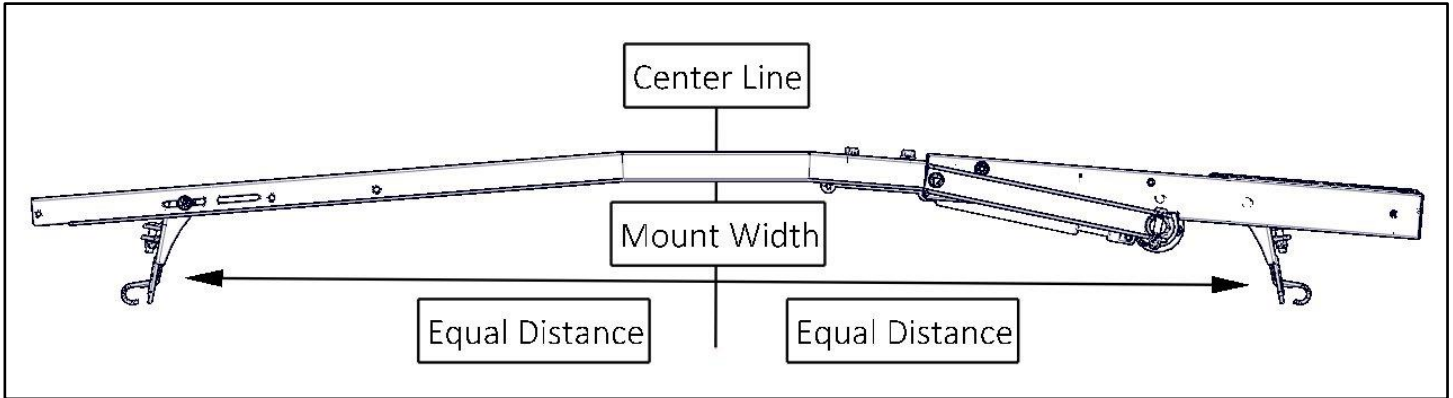

- Attach GM Foot (A) to both sides of each bow using 3/8" x 3/4" hex bolts (4) with lock washers (5) and flat washers (6) as shown.
- Leave loose until you set the assembly onto the vehicle. Most vans have a wider rain gutter at the front of the vehicle.

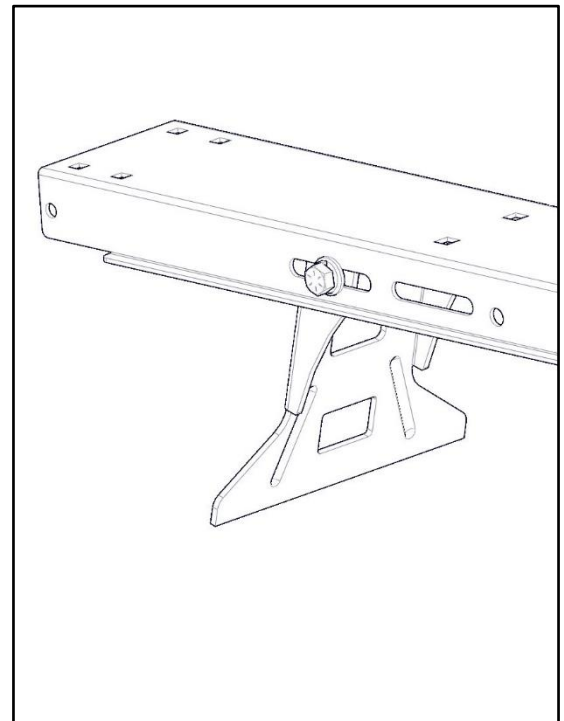
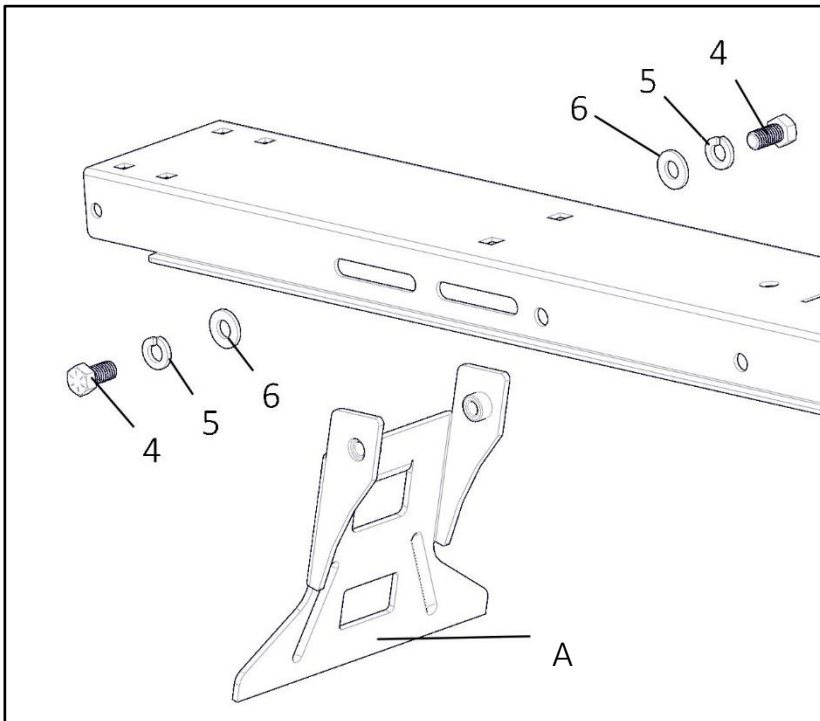

Step 2 – Attach to Rain Gutter

- Place rear bow assembly at rear of van, approximately 16" from rear of van.
- Be sure to have enough space for the handle to clear the rear of van when operating rack.

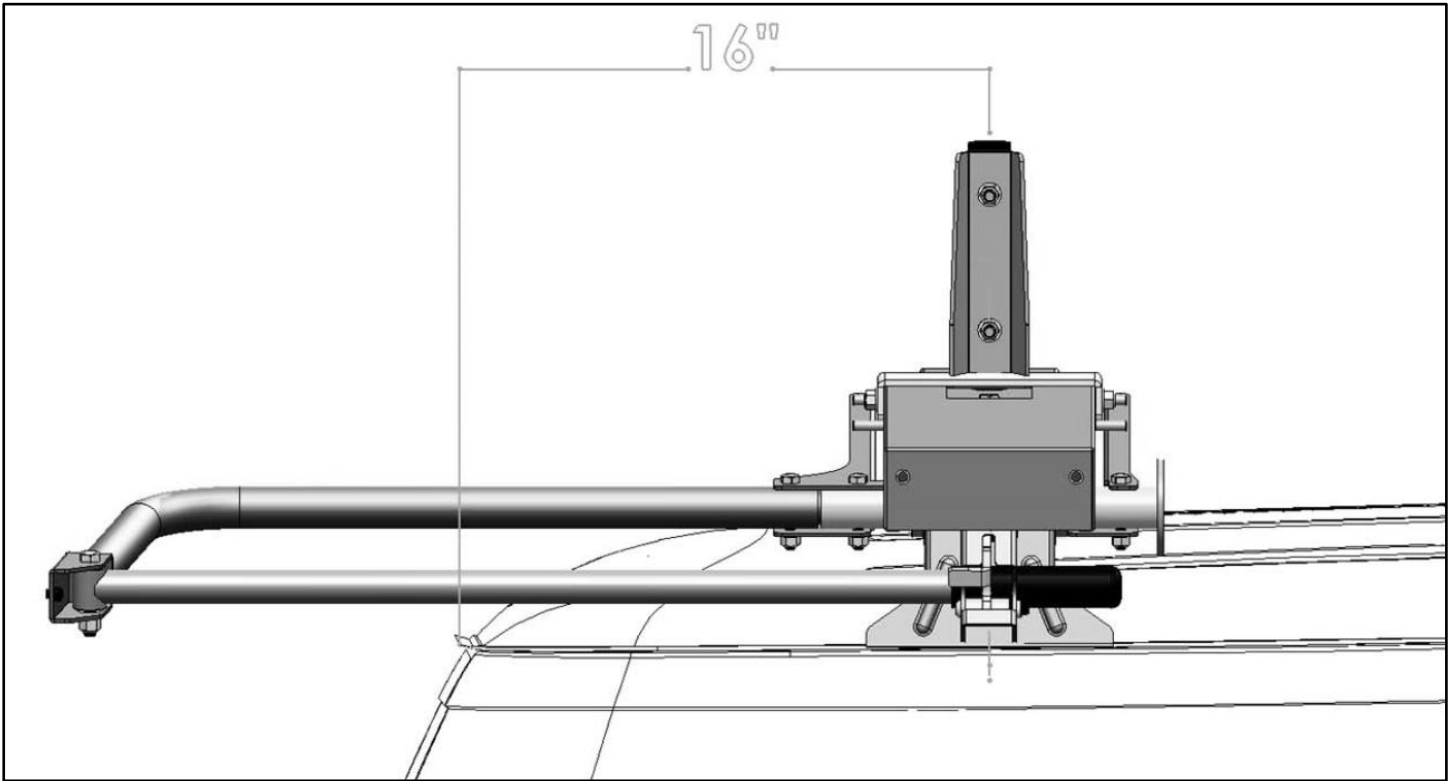

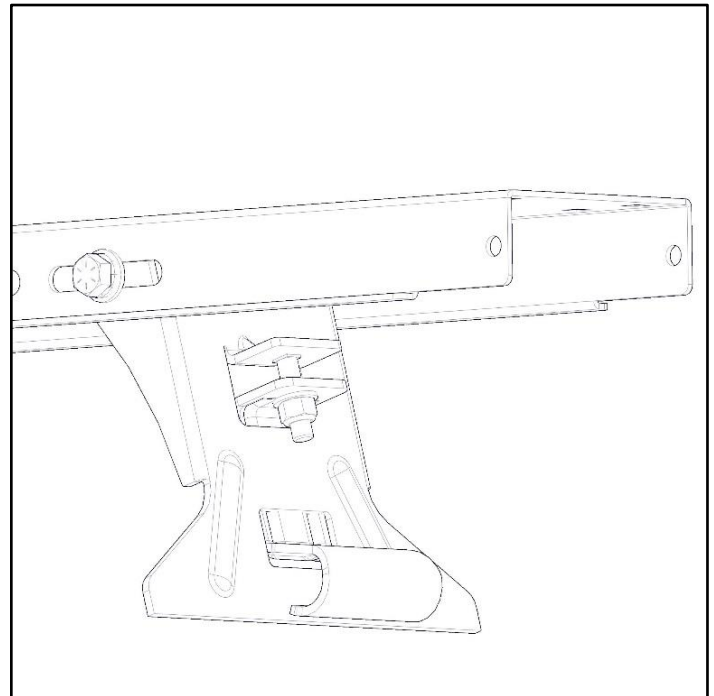
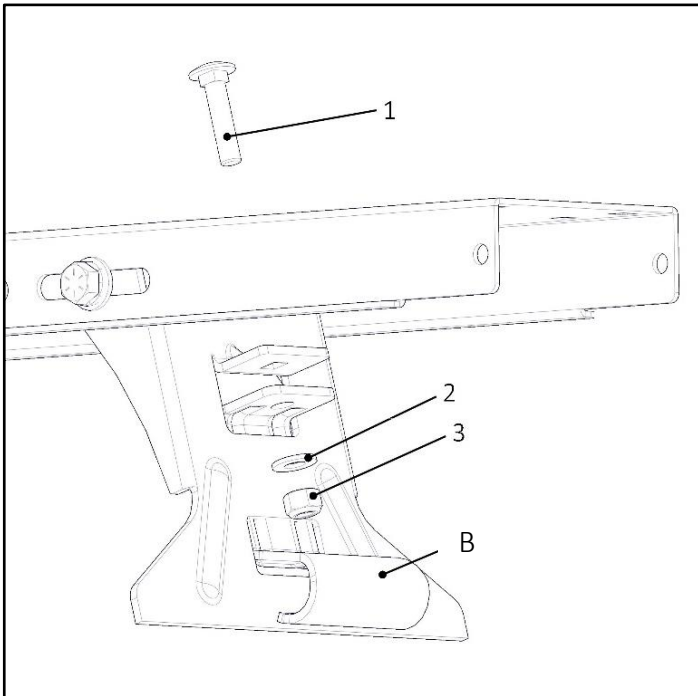

- Using a 5/16" x 1-1/2" carriage bolt (1), a 5/16" flat washer (2) and a 5/16" nyloc nut (3), insert gutter mount (B) through mount foot (A).
- Be sure the rear bow assembly is secure, but can still be moved front to rear.
- Place front bow onto roof of van.
- Assemble rack as shown in the ladder rack instructions.
- Once the ladder rack is square and aligned to the users desire, TIGHTEN.
- Repeat on all four corners of van.

Shown without van for clarity

GO BACK AND ENSURE ALL HARDWARE IS TIGHT

Your installation is now complete.

KARGO MASTER®

WE PUT EVERYTHING WITHIN REACH.

Installation Guide

4A92L

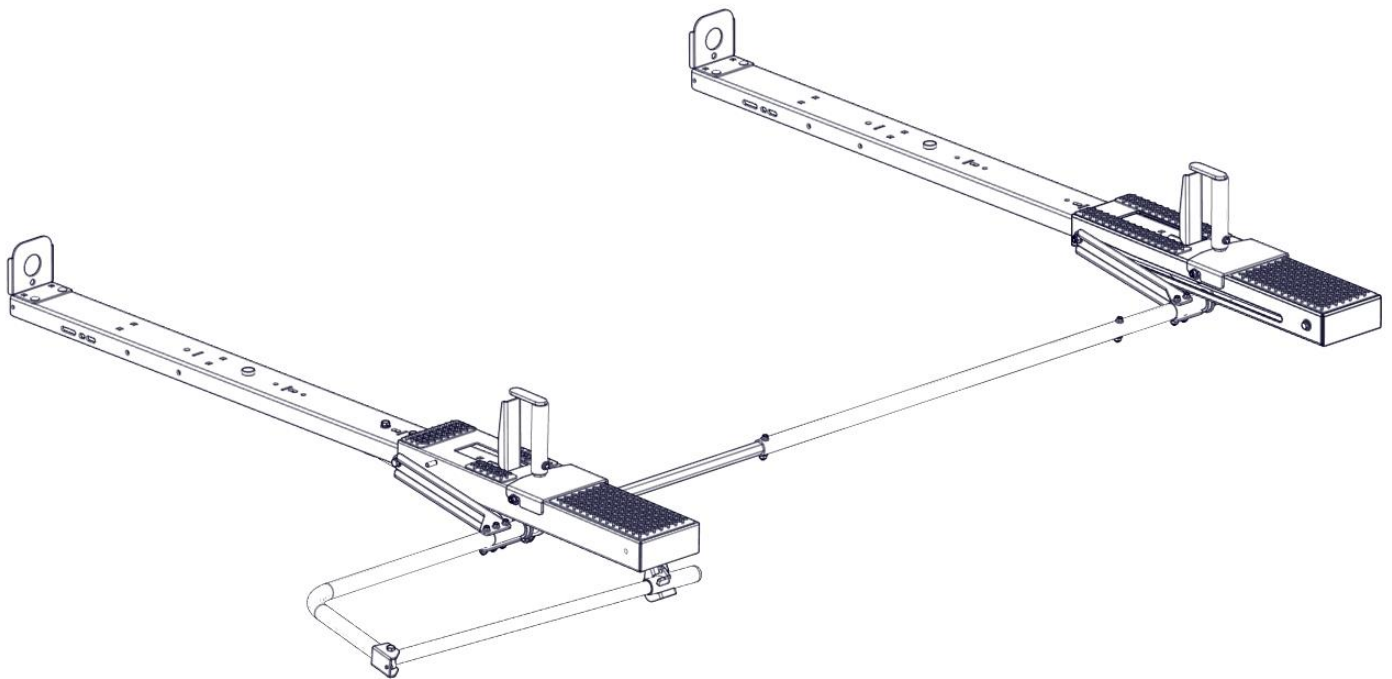

*PLEASE READ ALL INSTRUCTIONS AND WARNINGS PRIOR TO ASSEMBLING,
INSTALLING, AND USING THIS PRODUCT*

Warning



Always check for wires, fuel tanks and lines, brake lines and other important vehicle functionality items prior to drilling and installing all products.





Tools Needed

5/16" Wrench and Socket	3/8" Wrench and Socket
1/2" Wrench and Socket	9/16" Wrench and Socket
Tape Measure	

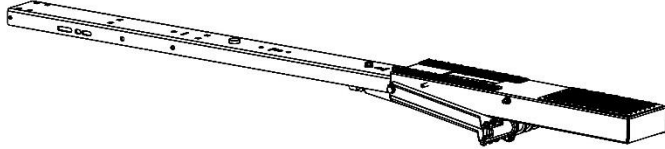
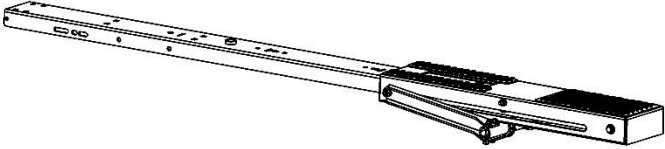
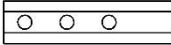
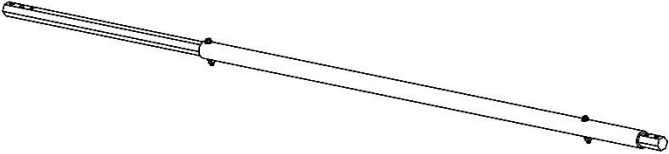
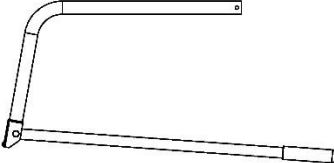

Before You Begin

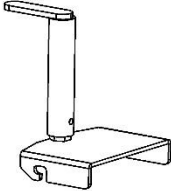
- Read all instructions.
 - Have mount kit installed on vehicle.
 - Front Bow has slot in ladder pan.
 - NEVER EXCEED MANUFACTURERS ROOF WEIGHT RATING.
-

Parts

ITEM NO.		DESCRIPTION	QTY.
A		REAR BOW	1
B		FRONT BOW	1
C		3-HOLE HEX	1
D		HEX TUBE ASM	1
E		HANDLE ASM	1
F		LATCH ASM	1
G		LADDER HOOK	2
H		LADDER STOP	2
J		LOAD PLATE	2
		HARDWARE-4A92L	1

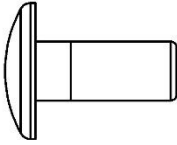
Hardware

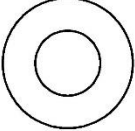
ITEM NO.	TO SCALE	DESCRIPTION	PART NUMBER	QTY.
1		5/16"-18 x 3/4" Carriage Bolt	90185A581	6
2		5/16"-18 Nyloc	95615A160	6
3		5/16" Flat Washer	98023A030	6
			ANTI-SEEZE	1

Step 1 – Load Plates

- At the end of each bow, opposite from the pan mechanism, bolt load plates (J) using two 5/16" x 3/4" carriage bolts (1), two 5/16" flat washers (2) and two 5/16" nyloc nuts (3) in the orientation shown.
- If installing 4A963, Skip installing load plates.
- Repeat on both bows.
- Snug Tighten, but allow movement.

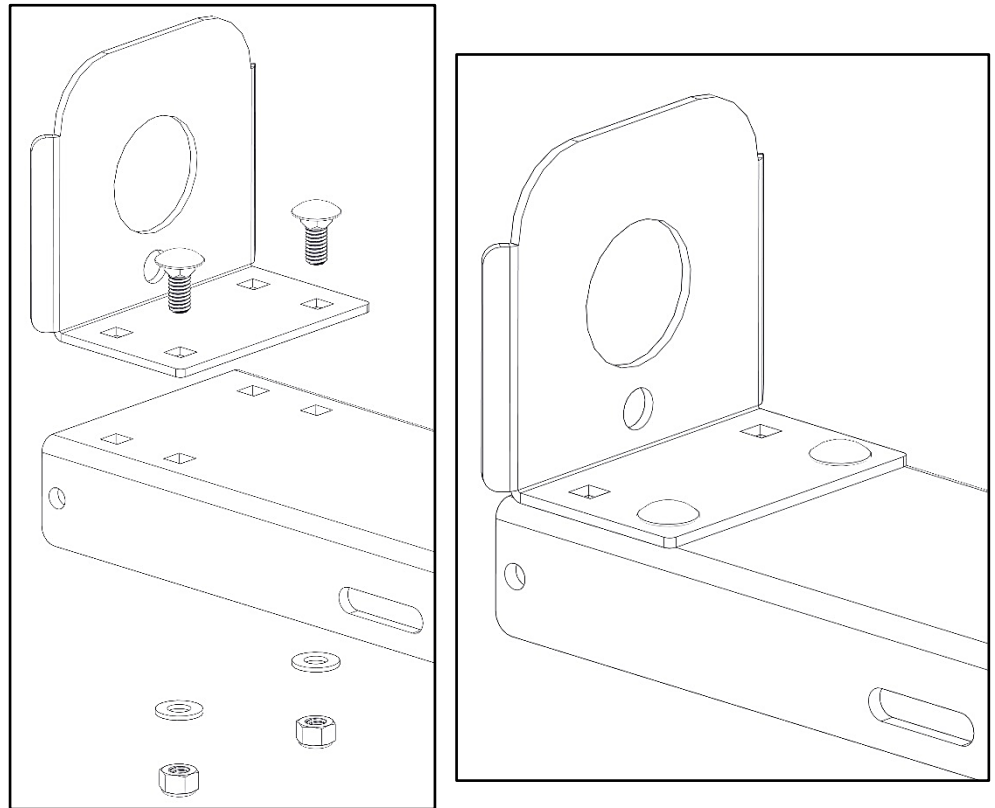

- Determine front and rear bow. The front bow will have a slot in the pan.

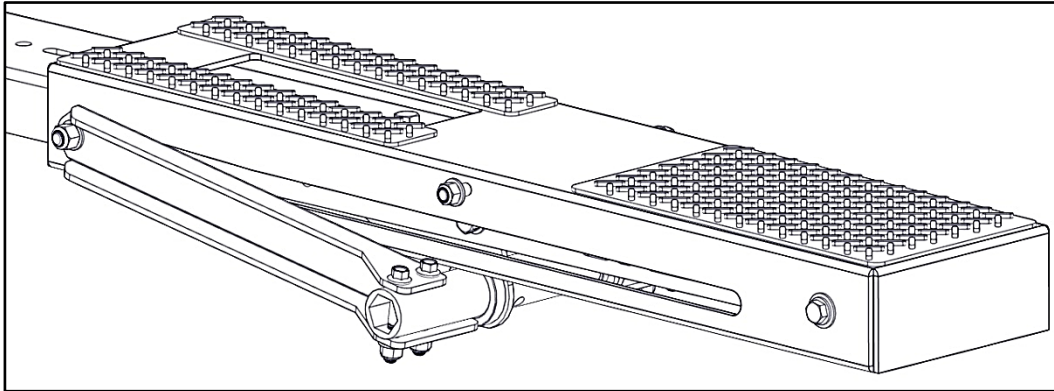

Front Bow

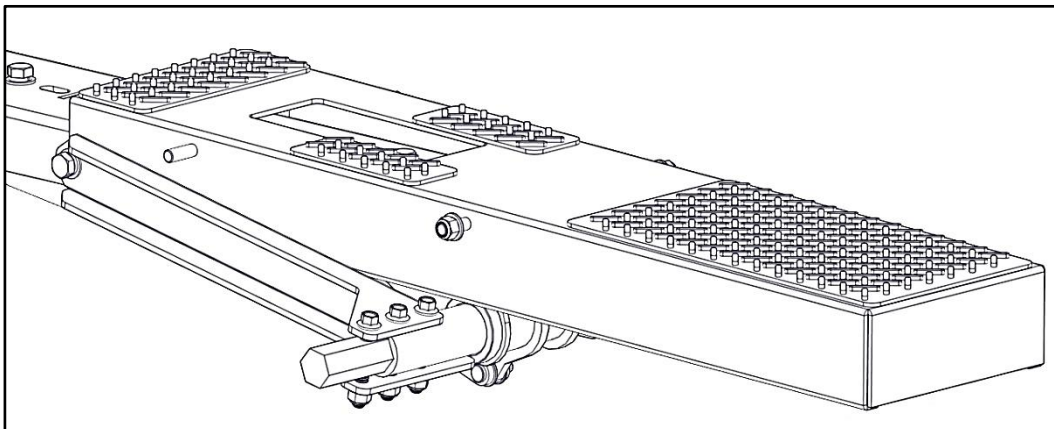

Rear Bow

Step 2 – Pan Mount

- Set Bow Assy (A&B) on mounting feet as shown. Follow instructions from the mount kit to install on vehicle.
- Place a foam block from the packaging to hold the bow in the up position in order to access the mounting slots.

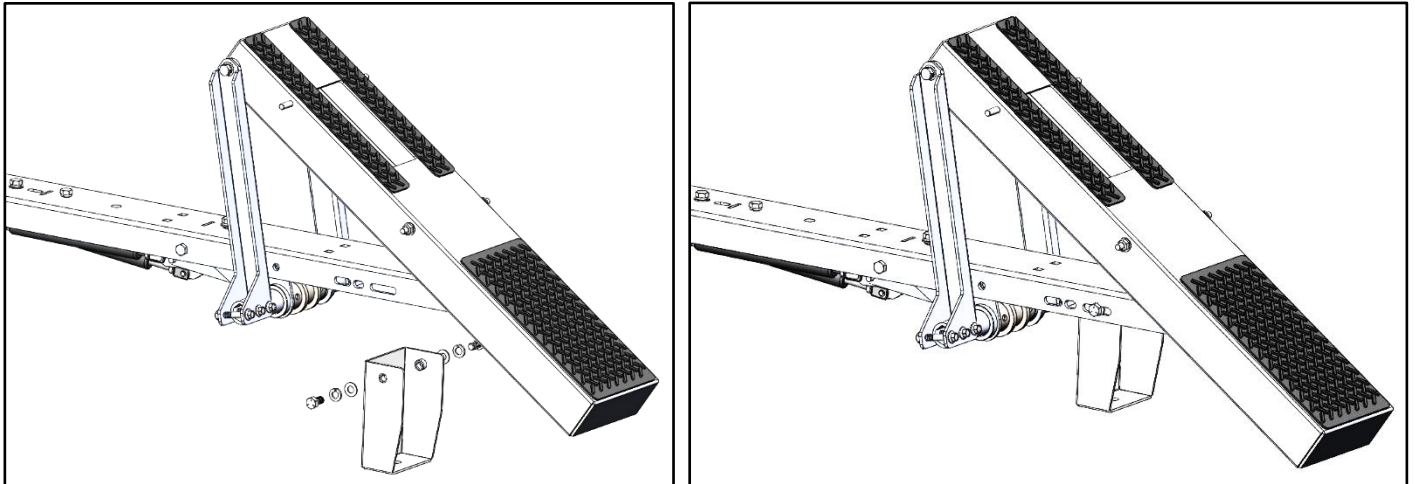

- Use 3/8" x 3/4" hex head bolts with 3/8" lock washers and 3/8" flat washers in order shown.
- Leave loose until the the rack is assembled.
- Repeat on both ends of bow.

Step 3 – Determine Hex Tube Length

- If the distance between the two bows is greater than 43", use the long hex bar as it comes assembled.

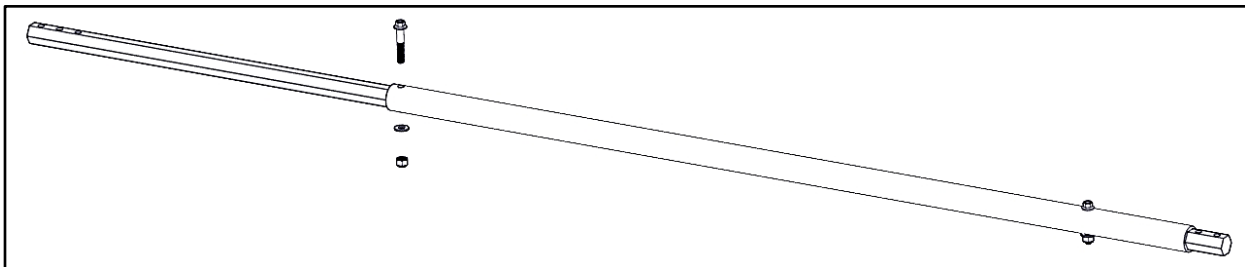

- If the distance between the two bows is approximately 43", remove the long hex tube from the assembly and use the small 3 hole hex tube (C).

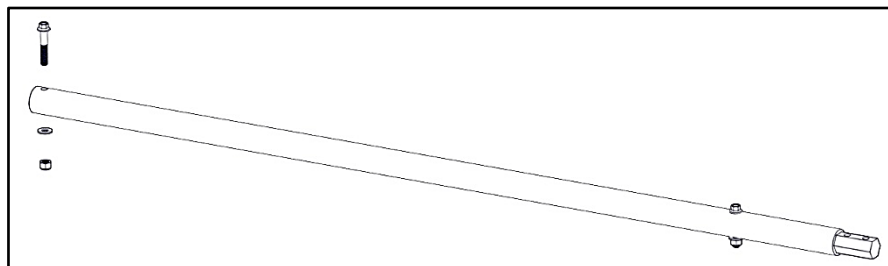

- In either case, remove bolt closest to the end of the hex sleeve that sets length of hex tube assembly, as shown.

Step 4 – Install Hex Tube

- Install hex tube to front pan assembly.
- Use the end of the hex tube assembly with 2 exposed holes to mount into the front pan.

Front bow shown

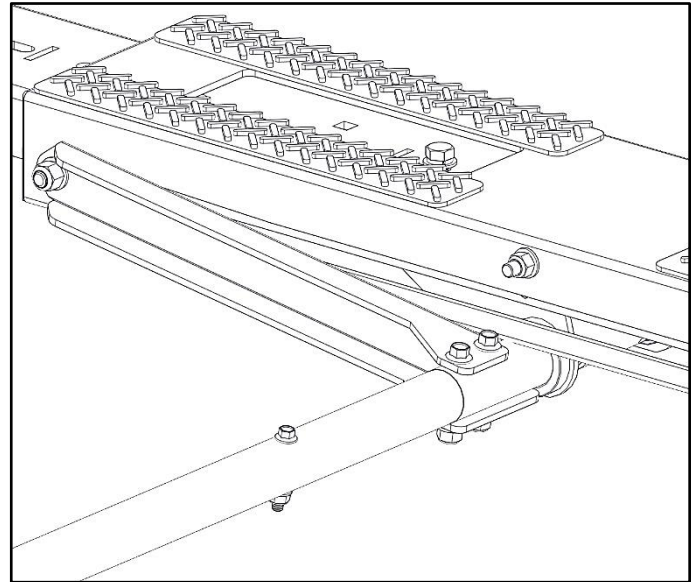
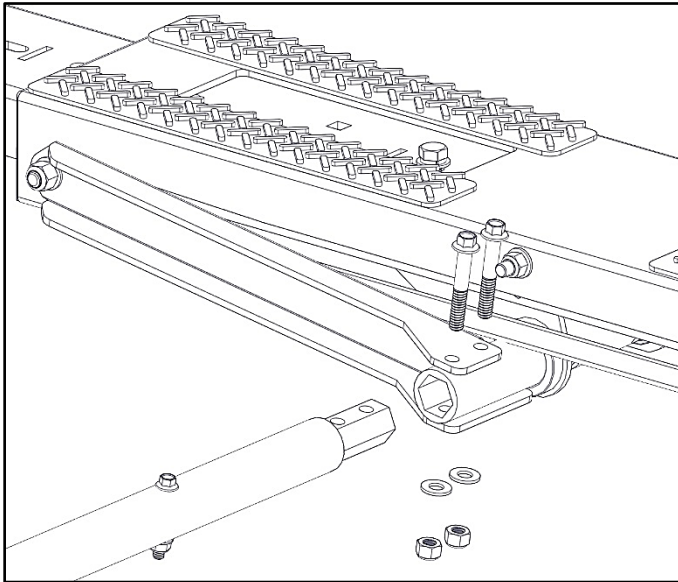

Rear bow shown below

- Slide hex tube and install on rear pan. (if distance between bows is approximately 43" use small 3 hole hex tube (C), see bottom set of pictures.)
- Bolt to rear pan using included hardware.
- Once bolted to rear pan, adjust hex tube to line holes up with the hex sleeve.
- Once aligned, bolt through both the hex sleeve and the hex tube using bolts from step 3.
- TIGHTEN all bolts from both front and rear pans.

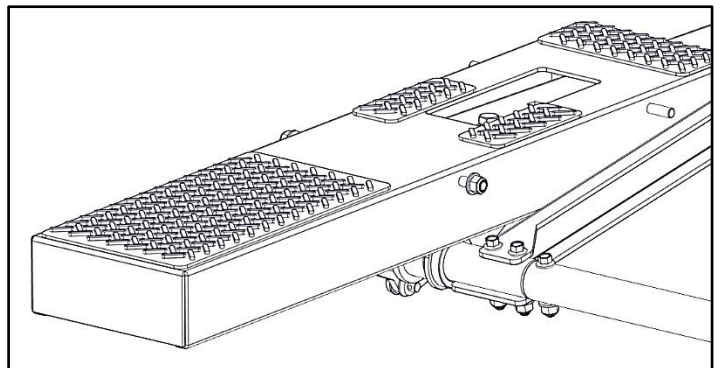
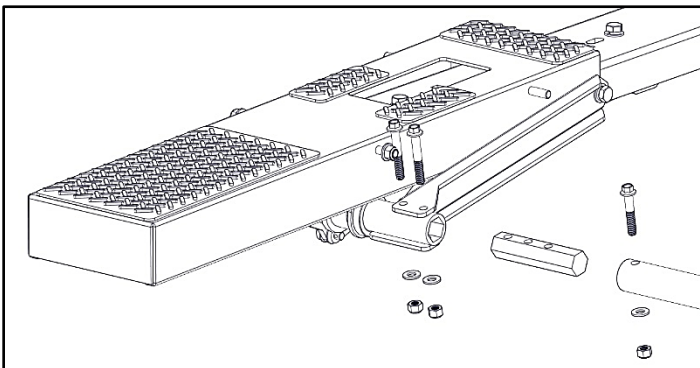
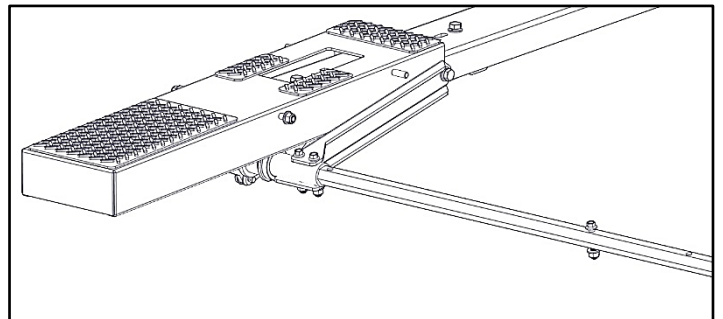
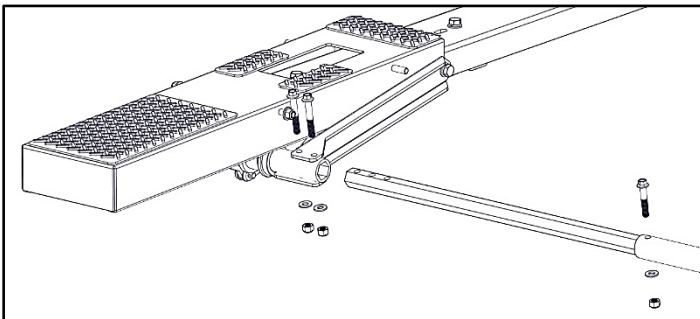

Step 5 – Install Latch

- Move rear pan assembly out of the way to expose the end of the crossmember.
- Bolt latch assembly (F) to end of crossmember using 5/16" x 3/4" carriage bolts (1), 5/16" flat washers (2) and 5/16" nyloc nuts (3).
- Shown without pan for clarity.
- TIGHTEN

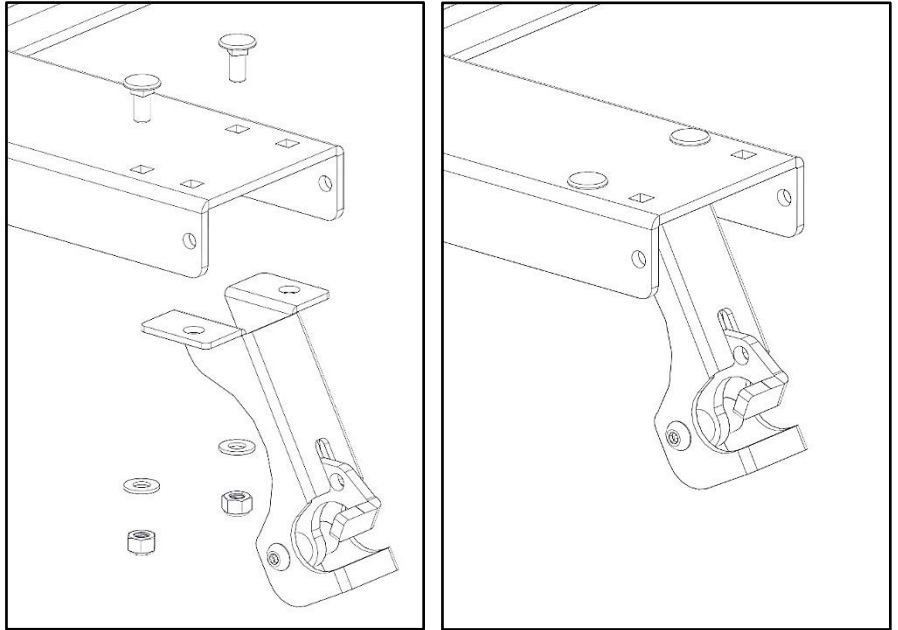

Step 6 – Install Handle

- Using the hardware in the rear bow to bolt handle (E) into position.
- TIGHTEN

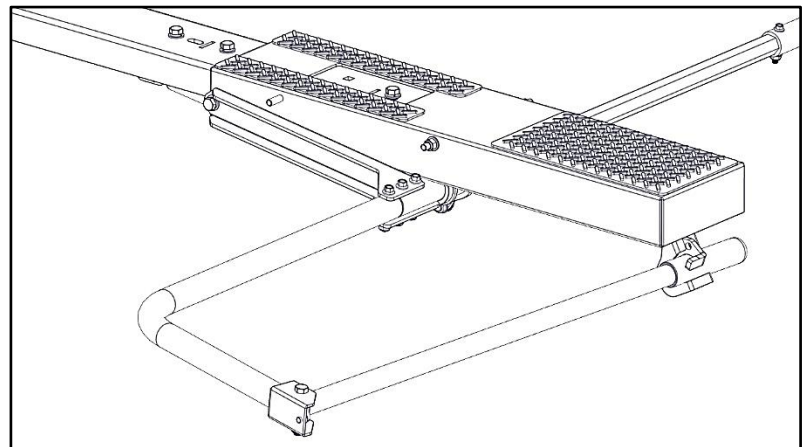
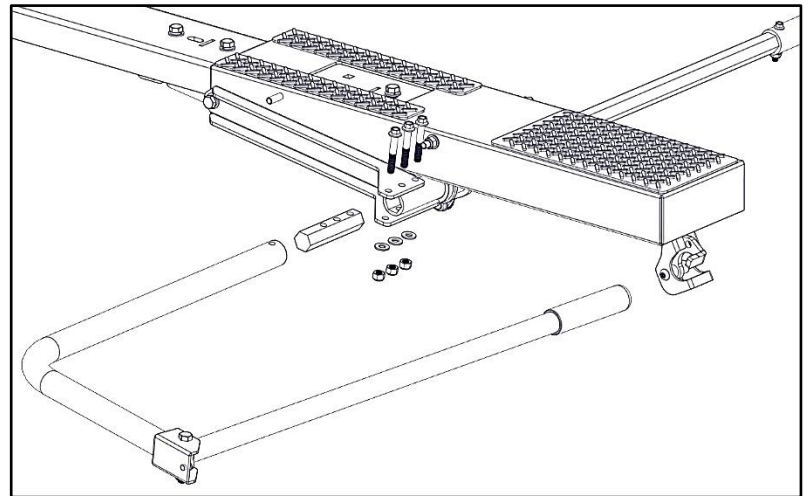

Step 7 – Ladder Stop

- Using the hardware in both bows, bolt ladder stop (H) in orientation shown. Be sure to place the tab on the ladder stop into the slot on the bow.
- TIGHTEN

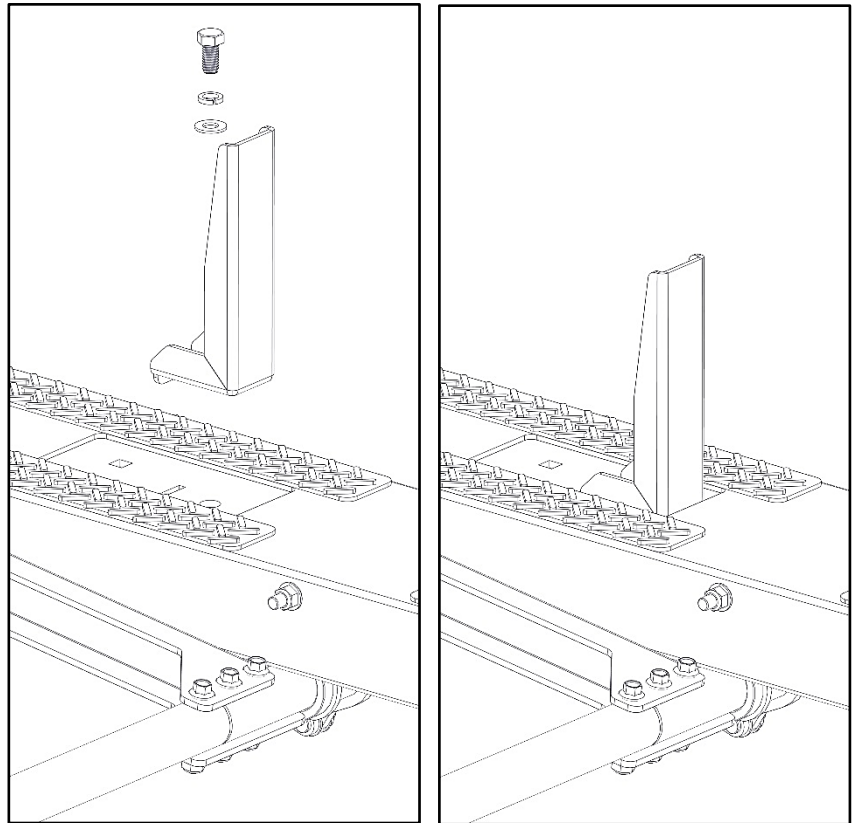

Step 8 – Ladder Hooks

- Using the hardware and installed pem studs on both bows, loosen nuts and slide ladder hook (G) into place.
- TIGHTEN

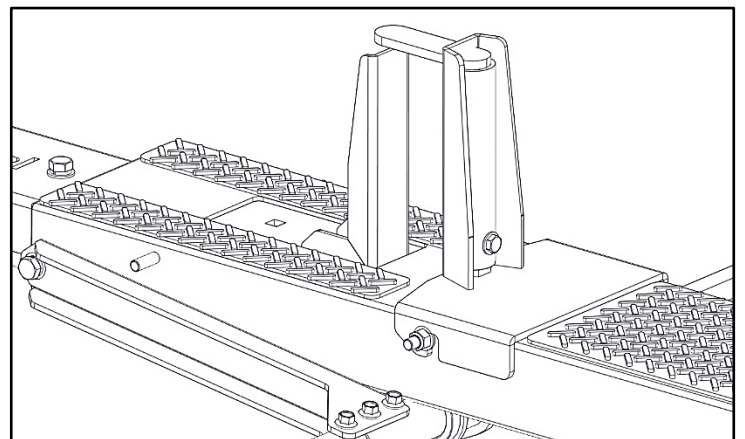
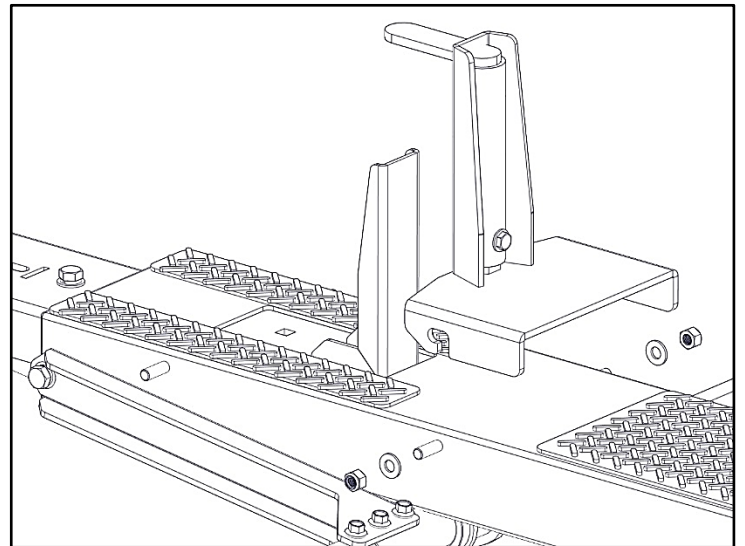

- The ladder hook may be adjusted up or down at 4 different locations.

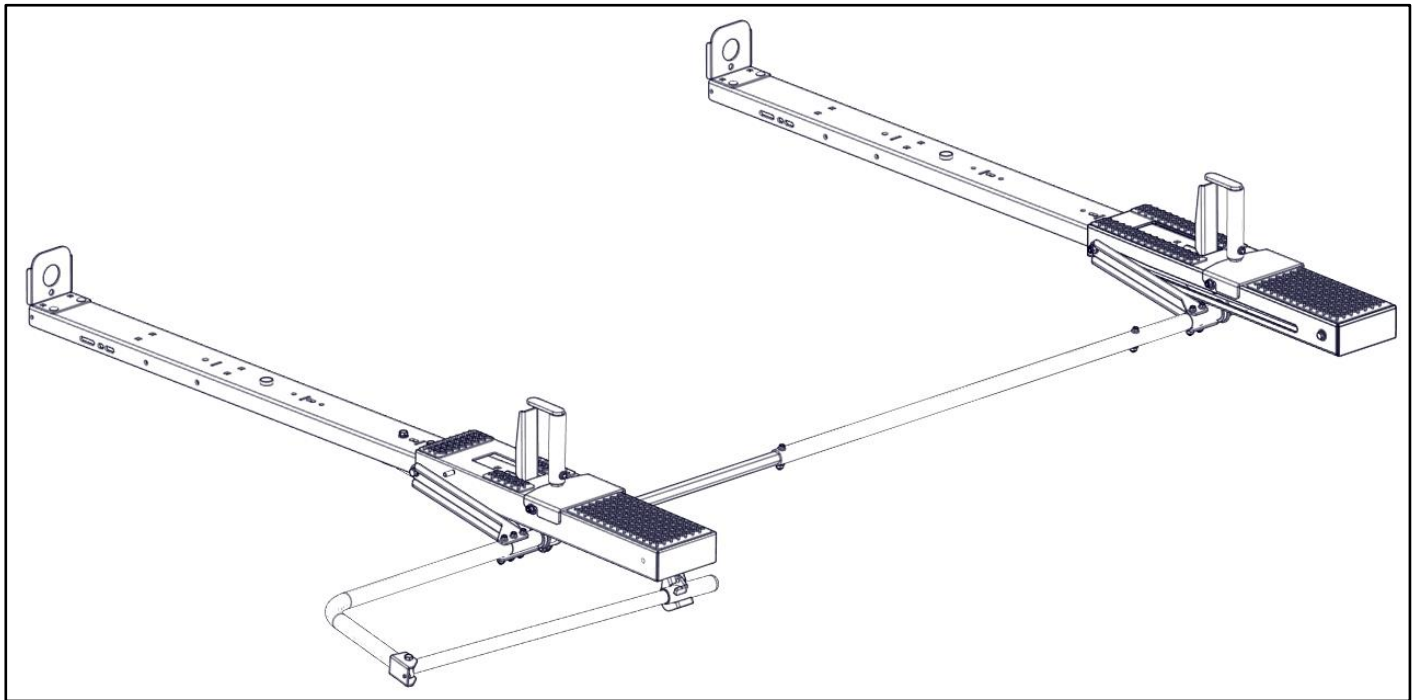
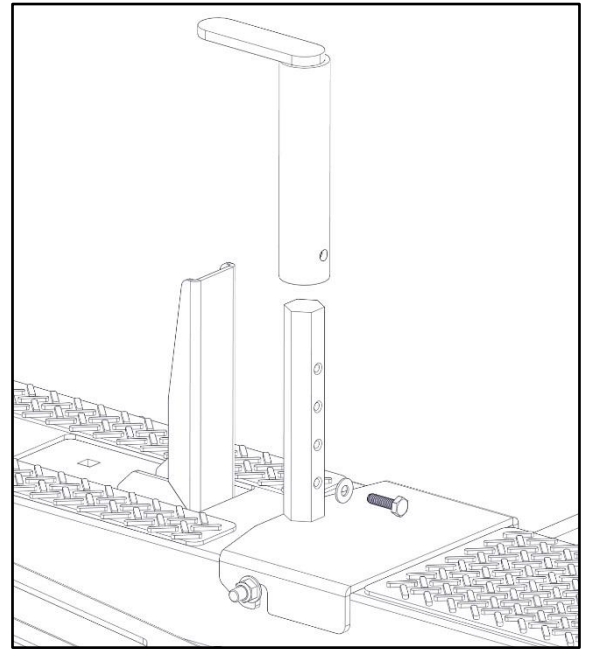

GO BACK AND TIGHTEN ALL BOLTS FROM PREVIOUS STEPS, BE SURE
HARDWARE IN MOUNTING IS TIGHT.

YOUR INSTALLATION IS NOW COMPLETE

KARGO MASTER®

WE PUT EVERYTHING WITHIN REACH.

Instruction Guide

4A81L

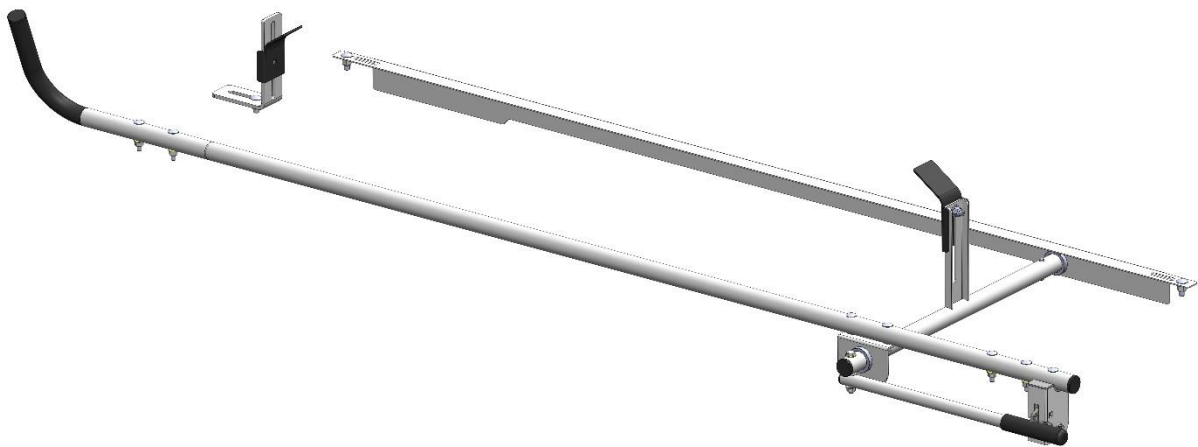

***PLEASE READ ALL INSTRUCTIONS AND WARNINGS PRIOR TO ASSEMBLING,
INSTALLING, AND USING THIS PRODUCT***

Warning



Always check for wires, fuel tanks and lines, brake lines and other important vehicle functionality items prior to drilling and installing all products.





Tools Needed

9/16" Socket and Wrench	1/2" Socket and Wrench
-------------------------	------------------------

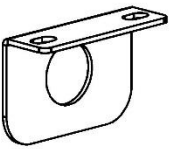
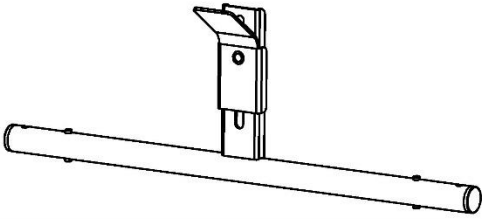
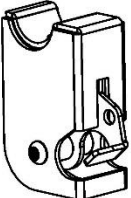

Before You Begin

- Read all instructions.
 - **DO NOT EXCEED MANUFACTURERS WEIGHT CAPACITY FOR ROOF.**
 - This kit is the Driver Side add on ONLY.
 - **BE SURE TO ADJUST LADDER CLAMPS ACCORDINGLY TO FIRMLY SECURE LADDER TO RACK.**
-

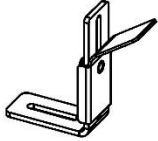
Parts

ITEM NO.		PART NUMBER	DESCRIPTION	QTY.
A		4A800-00-003-R3-L	Clamp and Lock L Bracket	1
B		4A800-50-001-R3	Side Tube	1
C		4A800-50-002-R2-L	Side Hook	1
D		11-03027A	Angle BRK	1
E		4A800-30	Clamp Tube	1
F		4A800-20	Latch Assy.	1
G		4A800-40	Handle	1
H		4A800-60	Ladder Stop Assembly	1
		18-4A81L	Hardware	1

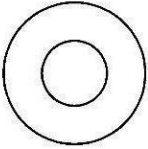
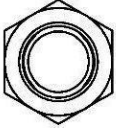
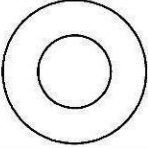
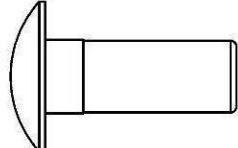
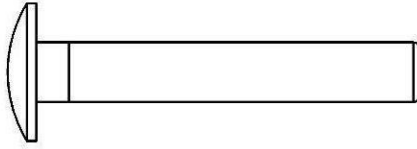
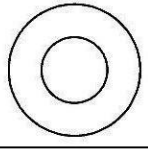
Assembly Hardware (18-4A81L)

ITEM NO.	TO SCALE	PART NUMBER	DESCRIPTION	QTY.
1		90295A160	.06x.34x.75 Nylon Washer	1
2		.375-16 NYLOC	3/8-16 Nyloc Nut	3
3		.375 FLAT WASHER	3/8 Flat Washer	3
4		.375-16 x 1 Carriage	3/8-16x1 Carriage Bolt	3
5		.312-18x2.0 CARRIAGE BOLT	5/16-18x2.0 Carriage Bolt	7
6		96659A107	5/16 FLAT WASHER	8
7		91831A030	5/16 NYLOC	8

Assembly Hardware (18-4A81L) Continued

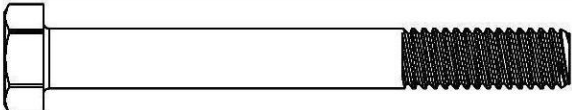
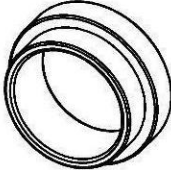
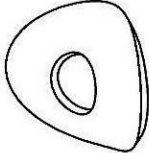
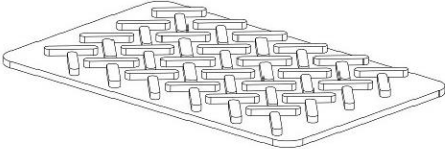
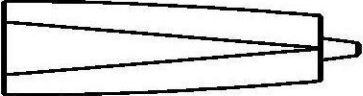
8		.312-18 X 2.75 HEX BOLT	5/16-18x2 3/4 Hex Bolt	1
9		40800-10-007	PLASTIC BUSHING 1:2 SCALE	2
10		91844A230	5/16 CONTOUR WASHER	1
11		Extra Rubber Pad	1:2 SCALE	1
		BH-821	Sealant	1

Step 1 – Remove Ladder Stops

- If havent already done so, remove ladder stops from opposite end of both bows where the clamp and lock is installed.

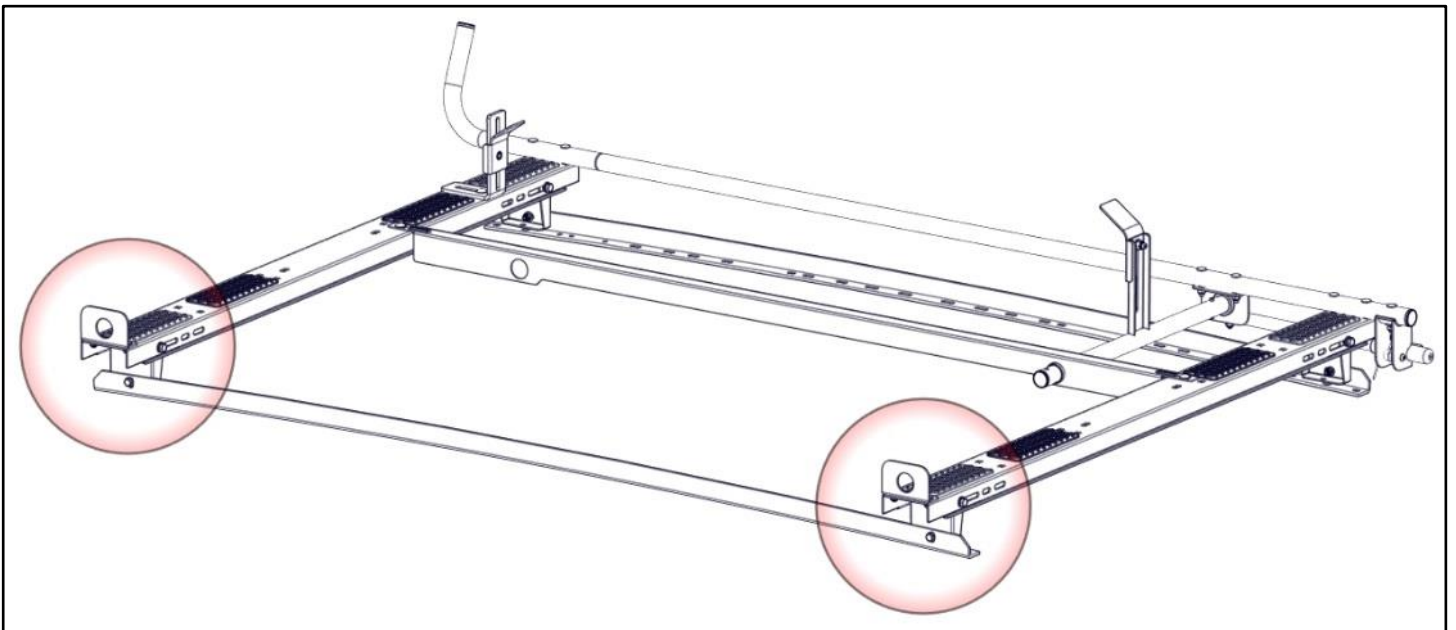
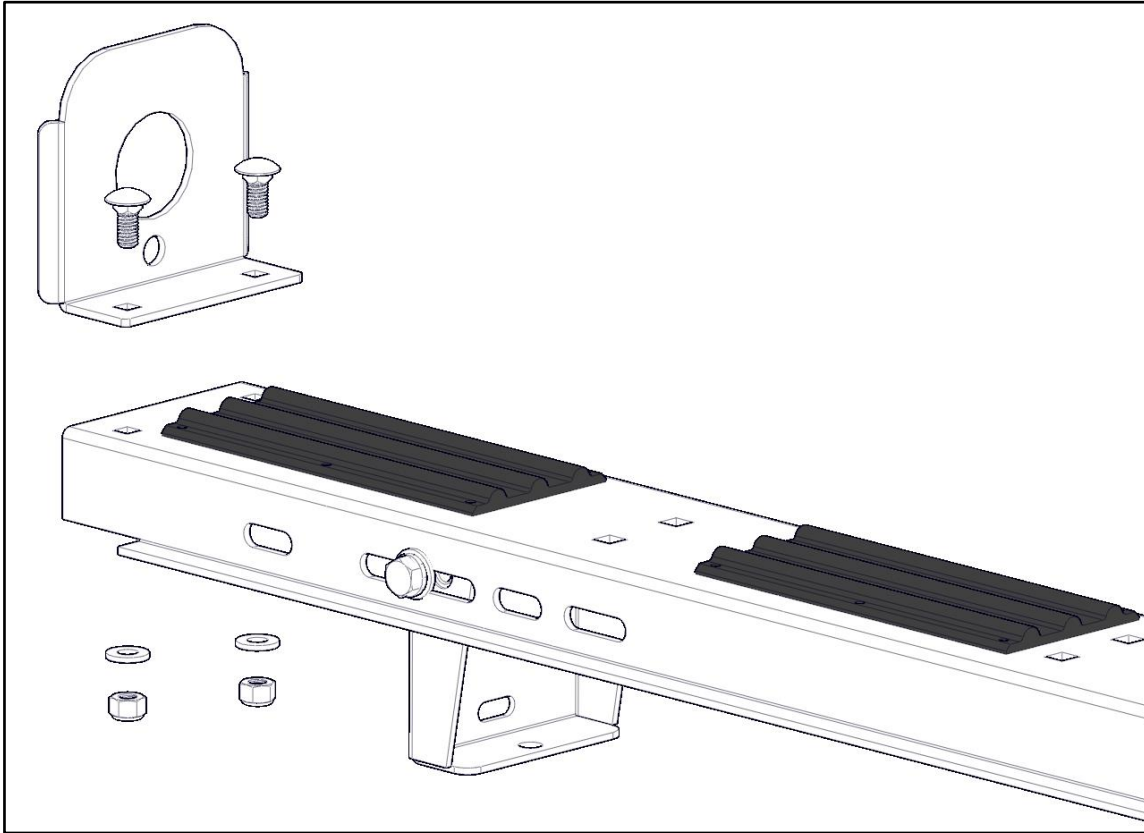

Step 2 – Mount Side Tube

- Place a generous amount of sealant into the tube connection.
- Place side tube on top of installed bows.
- Have the bend towards the front of the vehicle as shown.
- Mount rotation bar plate to the rear of the tube as shown.
- Leave one square slot open at the rear.
- Bolt together using 5/16" x 2" carriage bolt, a 5/16" flat washer and a 5/16" nyloc.
- Snug Tighten, but allow movement.

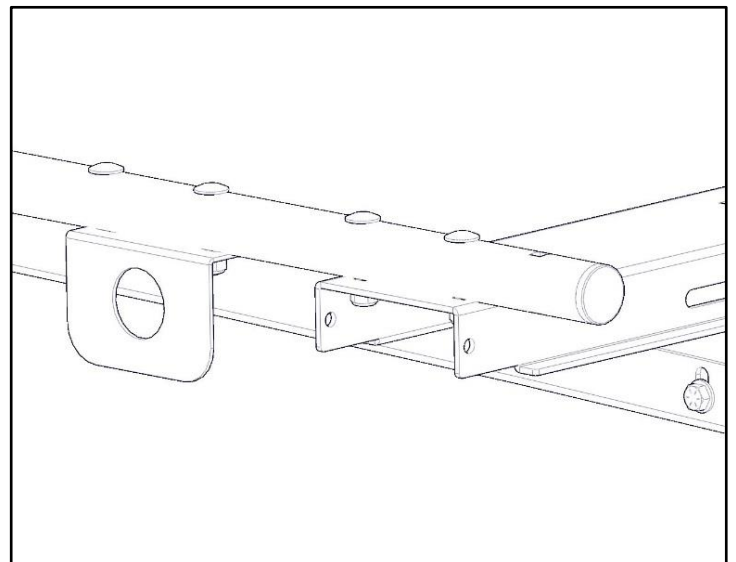
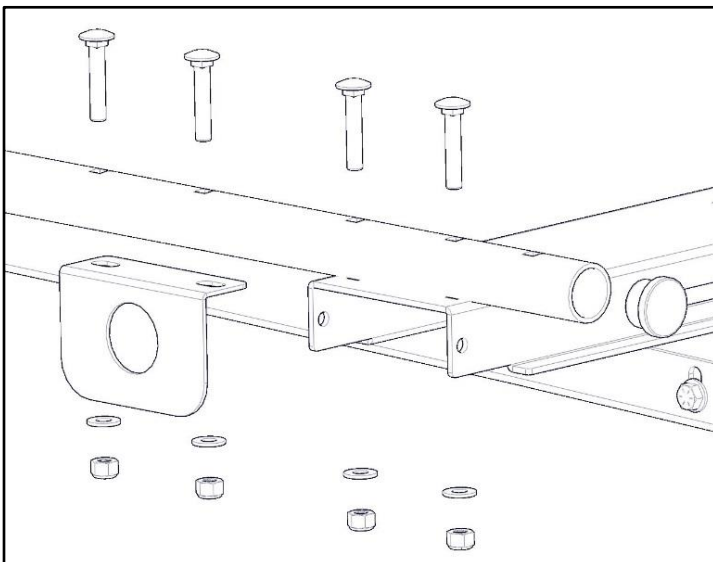
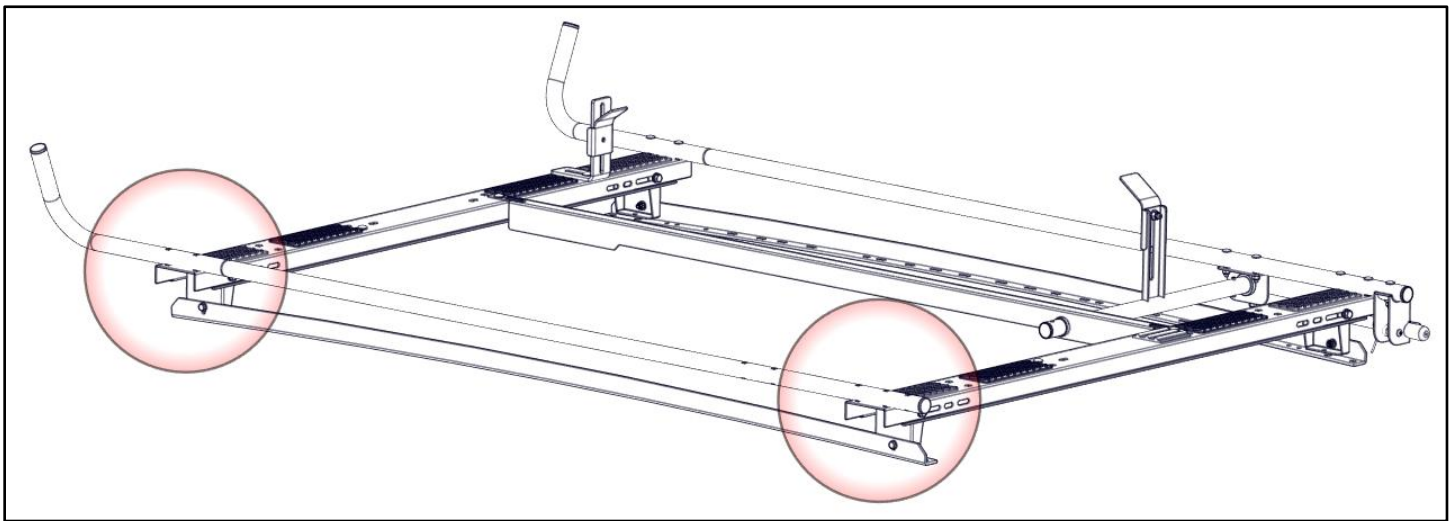
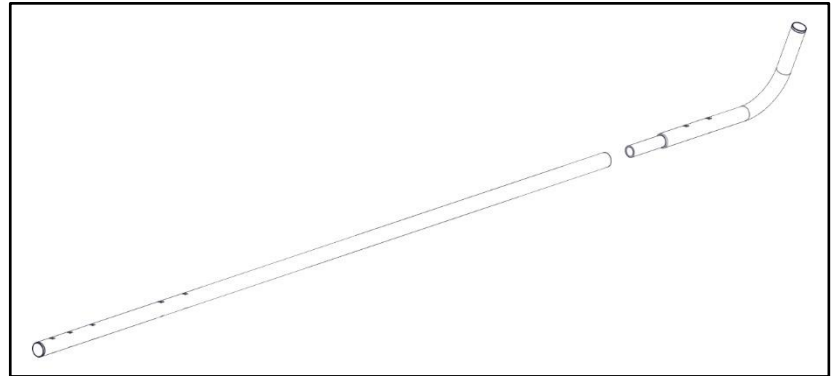

Step 3 – Mount Clamp Tube

- Place clamp and lock L bracket on top of installed bows. Do not install hardware right now.
- Insert plastic bushings into the clamp and lock L bracket and the rotation bar plate installed in Step 2, with flanges as shown so they cannot come out at a later time. If bushings are not placed in correct orientation, they can fall out.

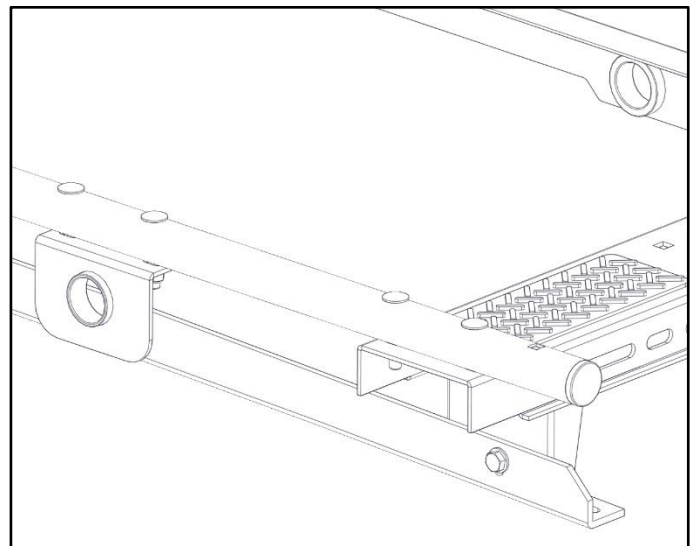
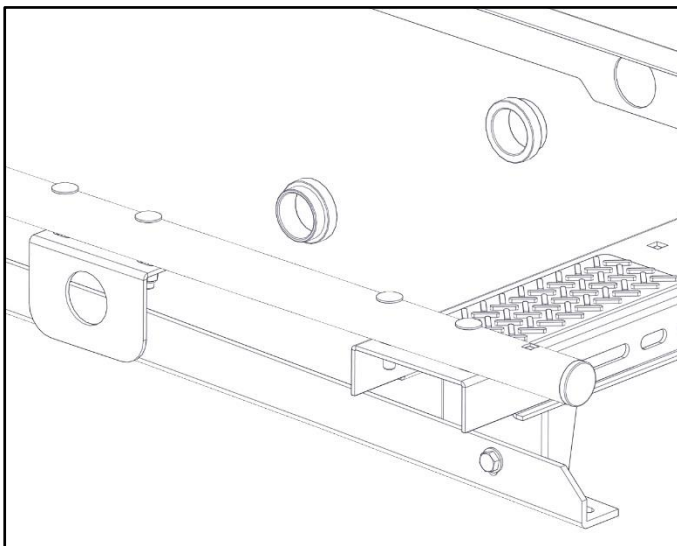
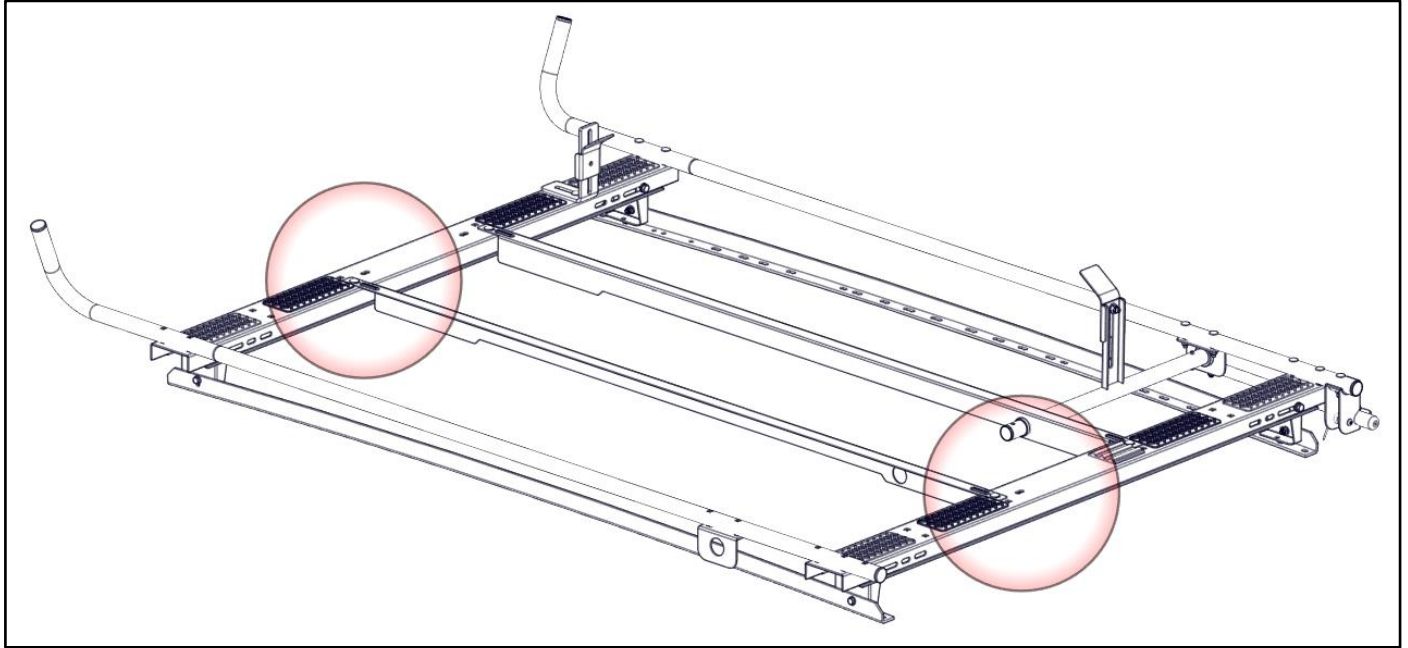

- Insert clamp tube into both plastic bushings.
- Adjust clamp on clamp tube to fit firmly against your ladder.

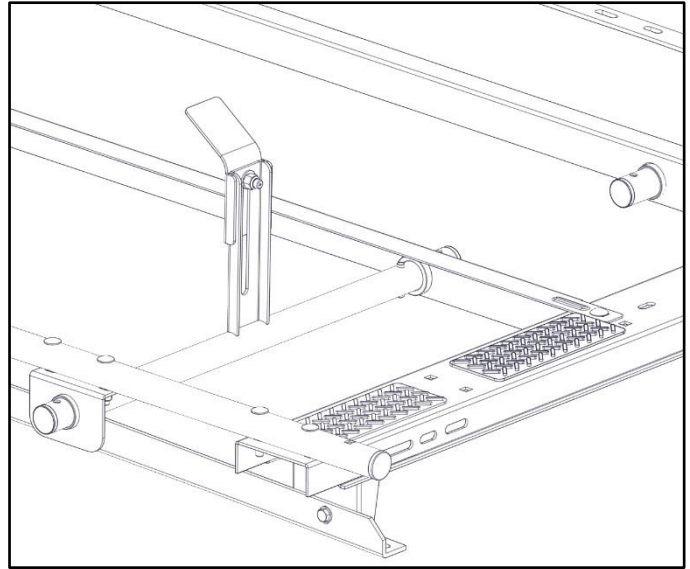
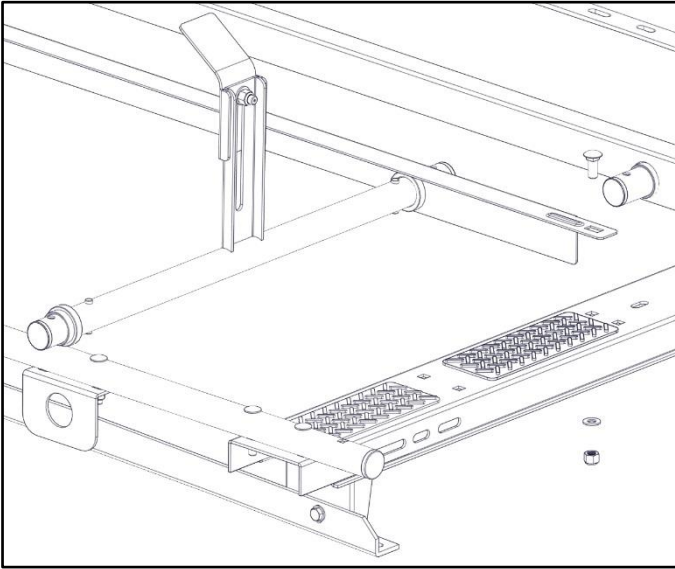

- Bolt clamp and lock L bracket to bows using 3/8" x 1" carriage bolt, 3/8" flat washer and a 3/8" nyloc as shown.
- TIGHTEN

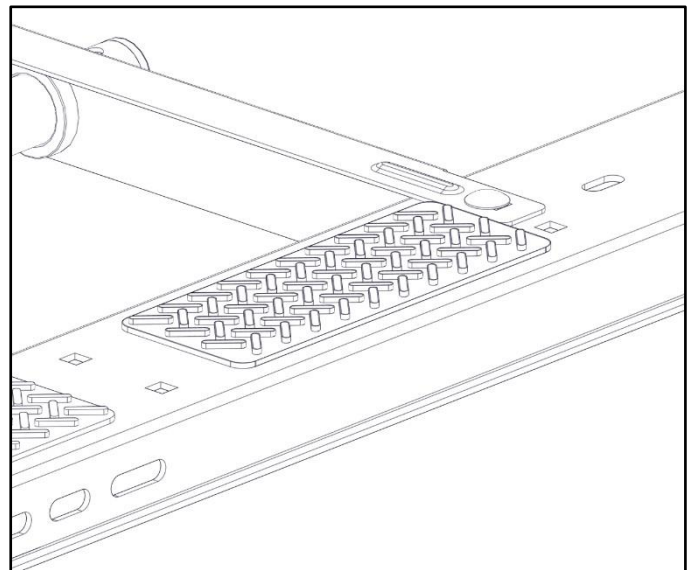
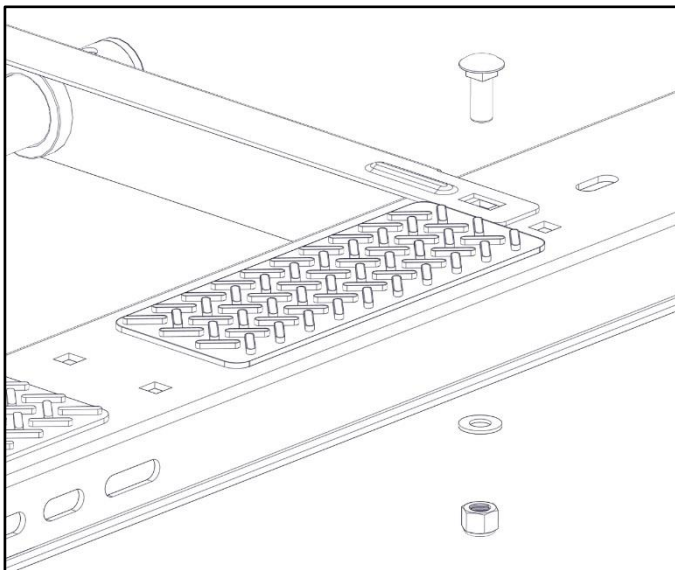

Step 4 – Mount Handle

- Bolt handle to clamp tube using a 5/16" x 2-3/4" hex head, two 5/16" flat washers, 5/16" nylon washer and 5/16" a nyloc. The nylon washer goes in between the clamp tube and handle.
- TIGHTEN

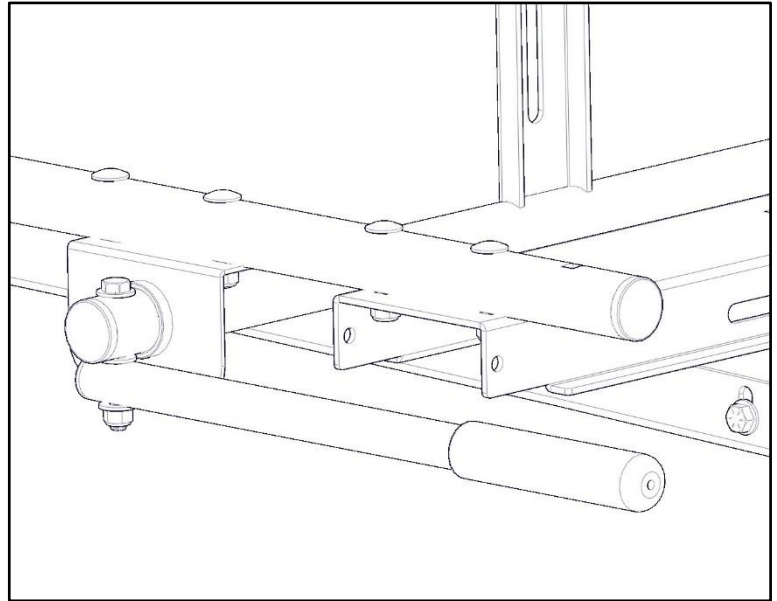
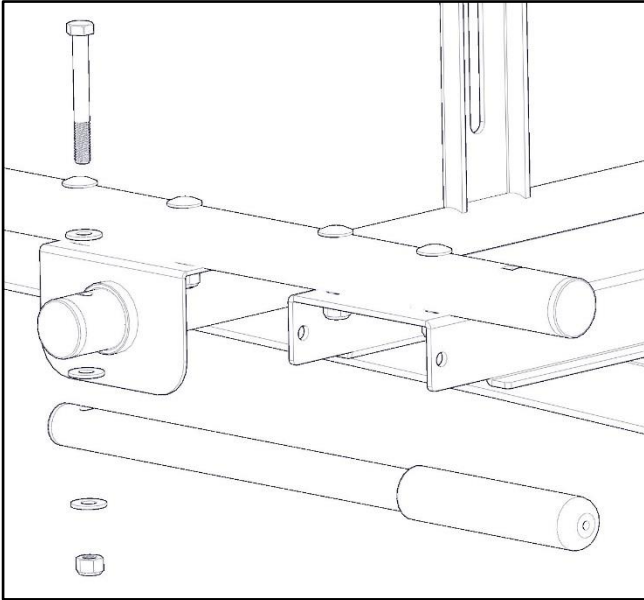

Step 5 – Mount Latch Assembly

- Bolt latch to the rear of the mount tube that was installed in Step 5 using 5/16" x 2" carriage bolt, 5/16" curved washer and a 5/16" nyloc.
- TIGHTEN

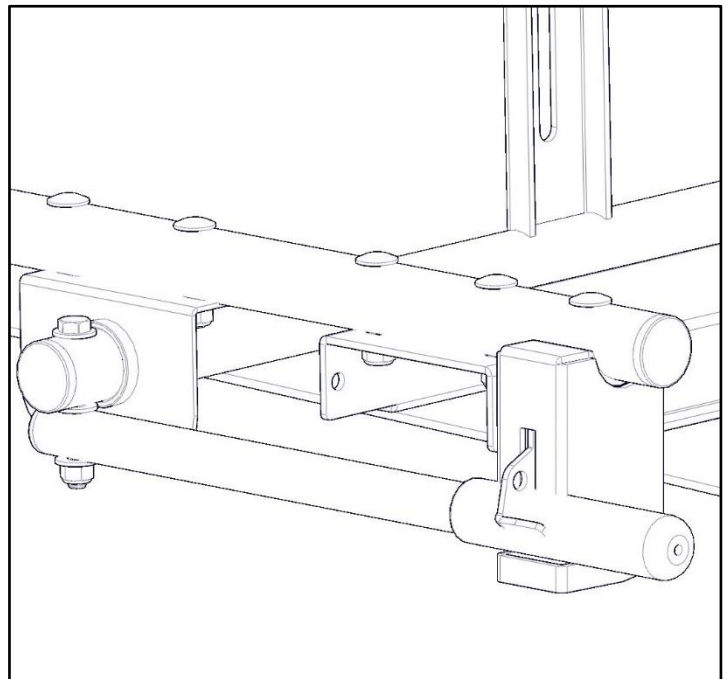
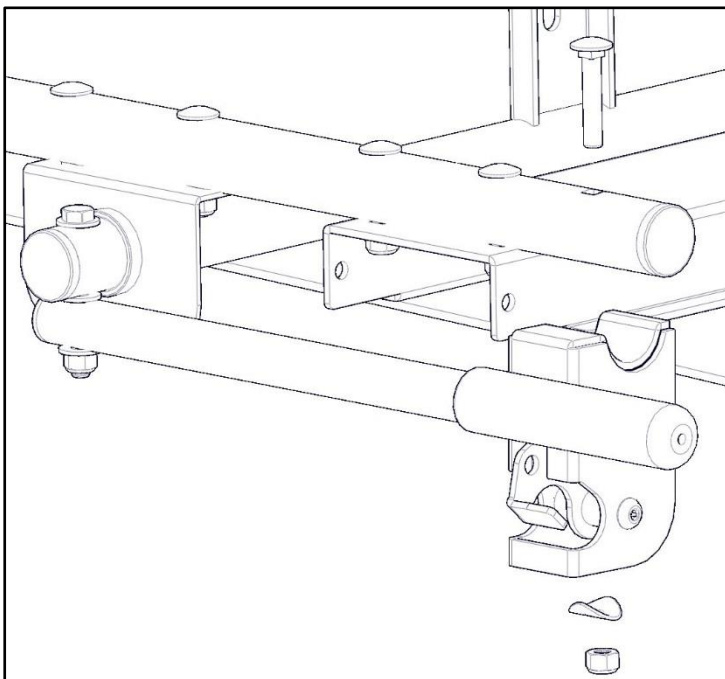

Step 6 – Mount Ladder Hook

- Bolt ladder hook bracket to the bow in the orientation shown using a 3/8" x 1" carriage bolt, a 3/8" flat washer and a 3/8" nyloc. Be sure the bracket is square to the bow.
- Adjust clamp on bracket to fit firmly against your ladder.
- TIGHTEN

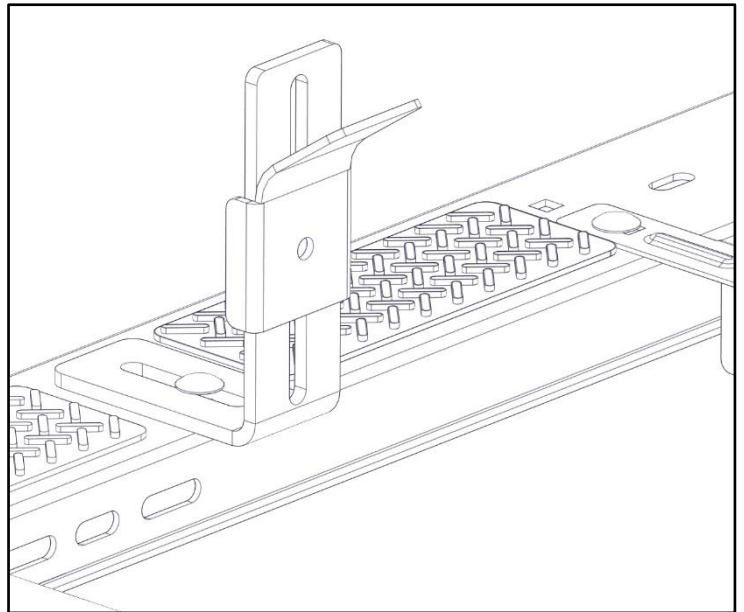
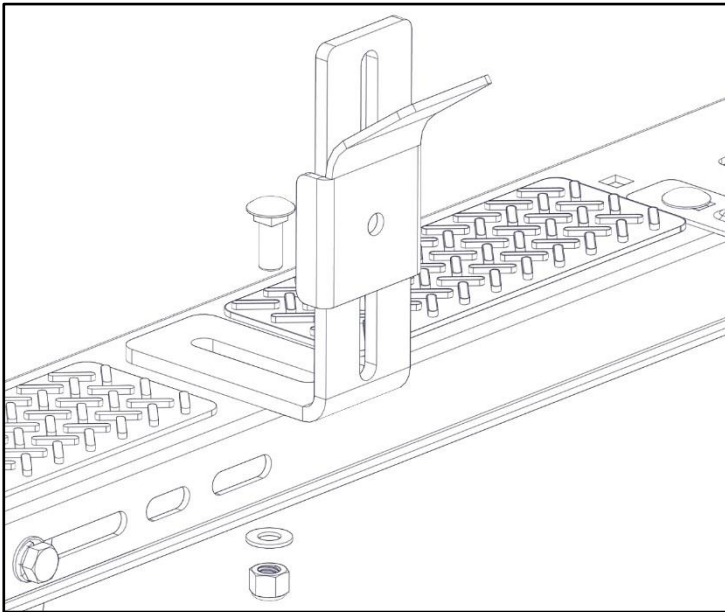

Step 7 – Install Extra Pad

- Adjust clamp on bracket to fit firmly against your ladder.
- If ladder rests on cross bow, place extra rubber bumper to avoid scratching.

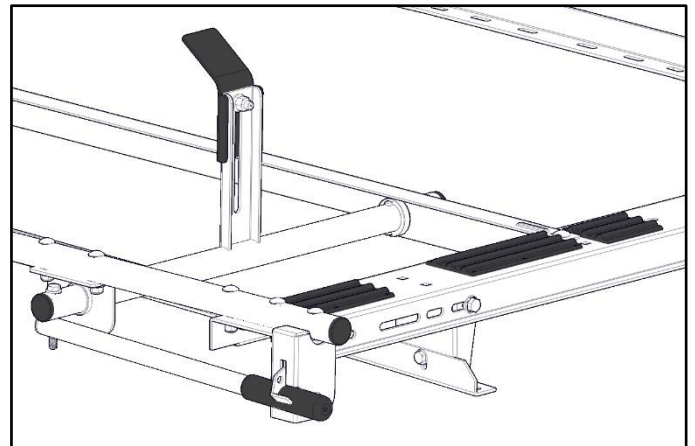
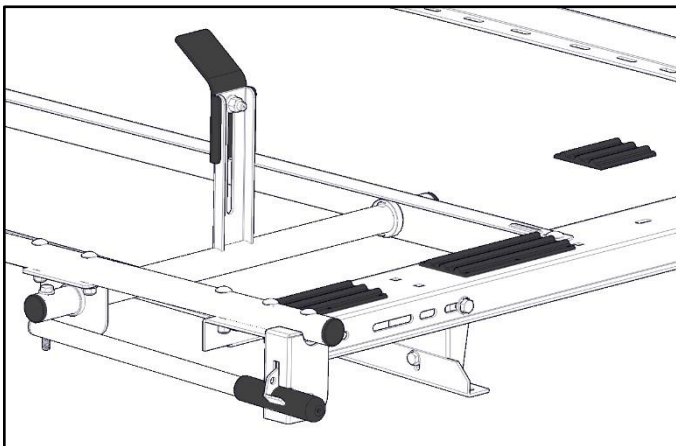

GO BACK AND ENSURE ALL HARDWARE IS TIGHT
Your installation is now complete.

BE SURE LADDER IS SECURE PRIOR TO TRANSPORTATION

