

---

# **KARGO MASTER®**

**WE PUT EVERYTHING WITHIN REACH.**

---

## Instruction Guide

8006A

---

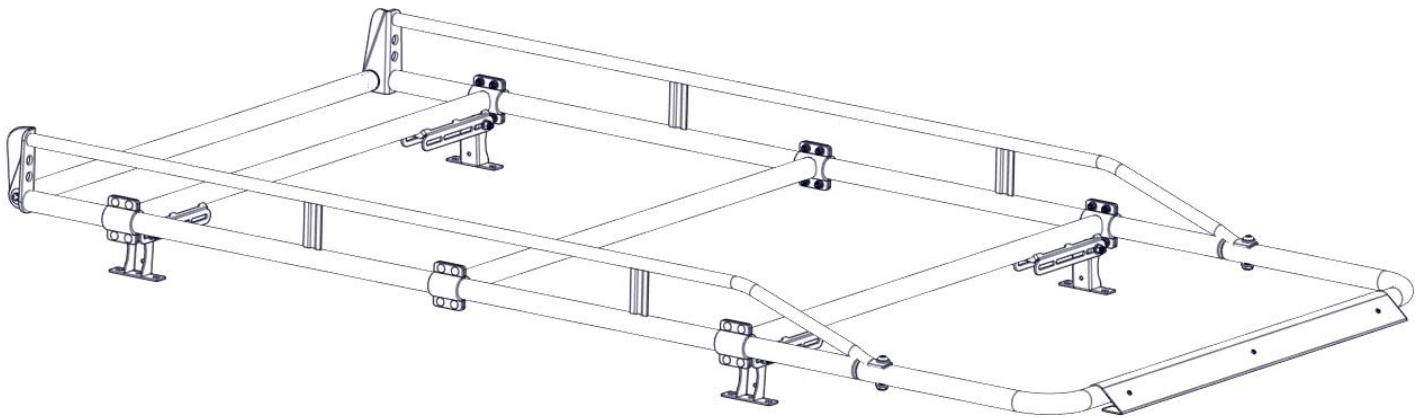

**\*PLEASE READ ALL INSTRUCTIONS AND WARNINGS PRIOR TO ASSEMBLING,  
INSTALLING, AND USING THIS PRODUCT\***

**Warning**



Always check for wires, fuel tanks and lines, brake lines and other important vehicle functionality items prior to drilling and installing all products.

**Tools Needed**

10mm Wrench and Socket	13mm Wrench and Socket
9/16" Wrench and Socket	1/2" Wrench and Socket
3/4" Wrench and Socket	5/16" Allen Hex
Phillips Driver	Tape Measure
5/16" Drill (Optional)	

**Table of Contents**

Parts List .....3

Assembly and Mounting Hardware .....4

Step 1 – Assemble Rack .....8

Step 2 – Mount Feet to Vehicle

    Step 2A – Transit Connect .....11

    Step 2B – Promaster City .....12

    Step 2C – NV200/City Express .....13

    Step 2D – Camper Shell .....14





Step 3 – Mount Crossbars to Feet .....15

Step 4 – Wind Deflector .....17

**Before You Begin**

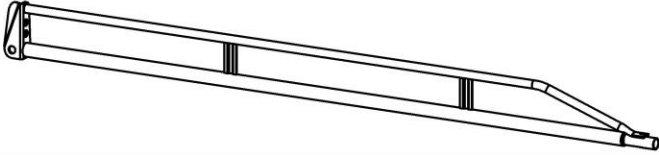
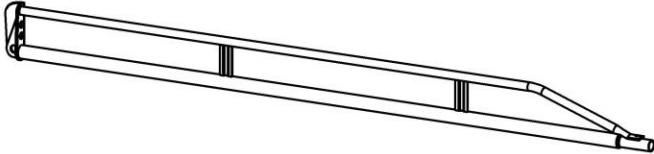
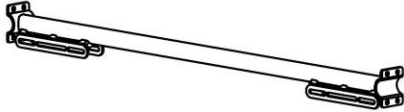
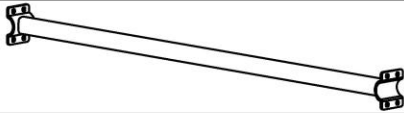
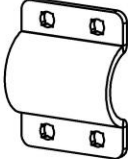
- Read all instructions.
- Be sure to put sealant around all holes entering cargo area and between the rubber pads and roof of vehicle to prevent water from leaking into cargo area.
- DO NOT EXCEED MANUFACTURERS WEIGHT CAPACITY FOR ROOF.

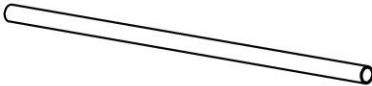

**Parts**

ITEM NO.		PART NUMBER	DESCRIPTION	QTY.
A		8006A-00-001	U TUBE	1
B		8006A-10-L	SIDE CHANNEL, DRIVER SIDE	1
C		8006A-10-R	SIDE CHANNEL, PASSENGER SIDE	1
D		8006A-20-R2	SUPPORT CROSS BAR	2
E		8006A-21	EXTRA CROSS BAR	1
F		8007A-00-003-R1	CLAMP	6
G		8006A-30	WIND DEFLECTOR	1
H		4A822-10-001	FOOT	4
J		8006A-40-1	ROLLER BAR	1
K		4089A-00-24-R1	WIND DEFLECTOR CLAMP	3
		18-8006A-M	HARDWARE, MOUNTING	1
		18-8006A-A	HARDWARE, ASSEMBLY	1
		18-8006A-C	HARDWARE, SHELL MOUNTING	1

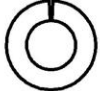
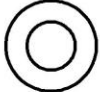
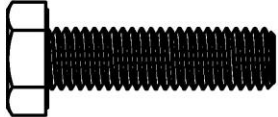
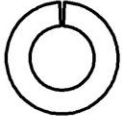
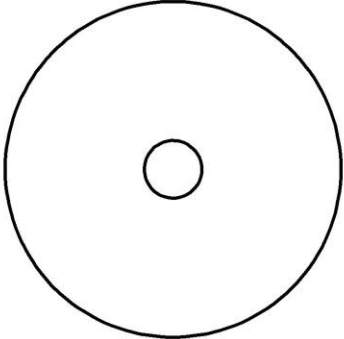
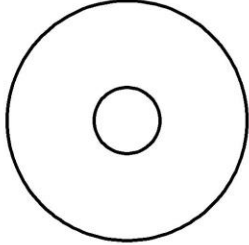

**Hardware (18-8006A-M)**

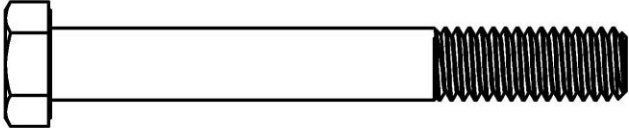
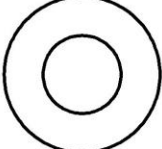
ITEM NO.	TO SCALE	PART NUMBER	DESCRIPTION	QTY.
1M		91287A137	M6x1 x 20mm HEX BOLT	8
2M		92148A180	M6 LOCK WASHER	8
3M		93475A250	M6 FLAT WASHER	8
4M		91287A154	M8x1.25 x 30mm HEX BOLT	4
5M		92148A200	M8 LOCK WASHER	4
6M		HW0001	5/16 OVERSIZE RUBBER WASHER	4
7M		90313A111	5/16 FENDER WASHER	4

**Hardware (18-8006A-M) Continued**

ITEM NO.	TO SCALE	PART NUMBER	DESCRIPTION	QTY.
8M		91247A636	3/8-16 x 3 HEX BOLT	4
9M		90126A031	3/8 FLAT WASHER	8
10M		97135A230	3/8-16 NYLOC NUT	4
11M		94639A866	3/8 SPACER	4

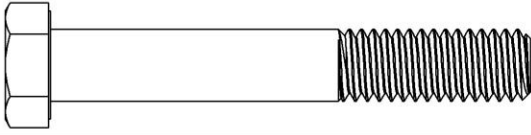
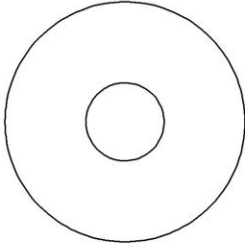
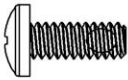
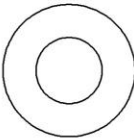
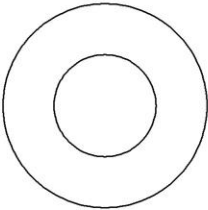
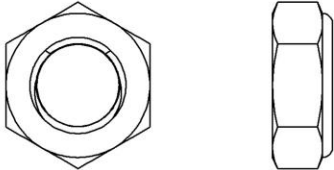
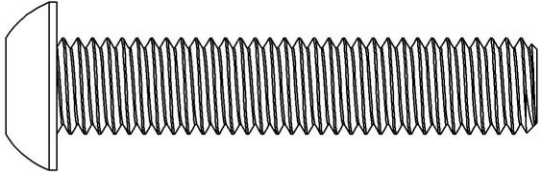
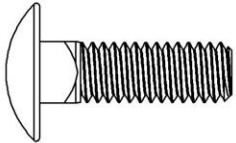

**Hardware (18-8006A-A)**

ITEM	HARDWARE TO SCALE	PART NUMBER	DESCRIPTION	QTY.
1A		11241202	3/8"-16 X 2-1/2" HEX HEAD BOLT	2
2A		33220	3/8" FENDER WASHER	2
3A		28956	10-24 X 1/2" PAN HEAD SCREW	3
4A		33080	5/16" WASHER	24
5A		11541086	1/2" WASHER	4
6A		37695	1/2"-13 THIN LOCKING JAM NUT	2
7A		0185355	1/2"-13 X 2-1/2" BUTTON HEAD BOLT	2
8A		21811	5/16"-18 X 1" CARRIAGE BOLT	24
9A		0169777	5/16"-18 NYLOC	24

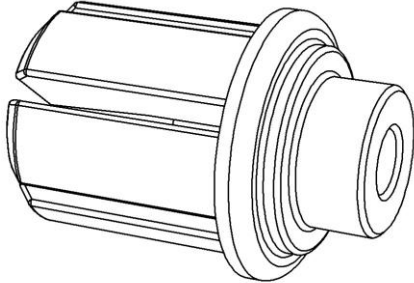
**Hardware (18-8006A-A) Continued**

ITEM	HARDWARE TO SCALE	PART NUMBER	DESCRIPTION	QTY.
10A			INSERT, BUSHING, ROLLER BAR, MODIFIED	2

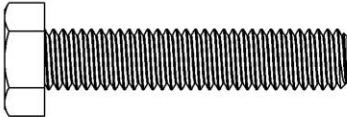
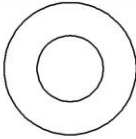
**Hardware (18-8006A-C)**

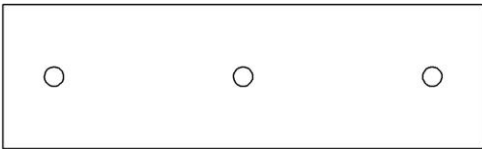
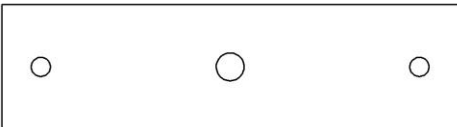
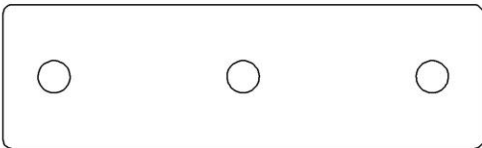
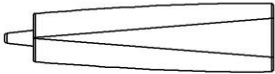
ITEM	HARDWARE TO SCALE	PART NUMBER	DESCRIPTION	QTY.
1		11114308	M8-1.25 x 60mm HEX HEAD BOLT	8
2		40357	M8 FLAT WASHER	16
3		11511017	M8-1.25 NYLON NUT	8
4		12-00231	3.5mm RUBBER PAD	4
5		40821-10-004	6mm PMC RUBBER PAD	4
7		80070-00-017	STEEL BACK PLATE	4
6		-	SEALANT	1

## Step 1 – Assemble Rack

- Assemble rear roller bar. Insert a bushing into each end of the rear roller bar as shown.
- Place sealant around the tube prior to inserting the bushings.

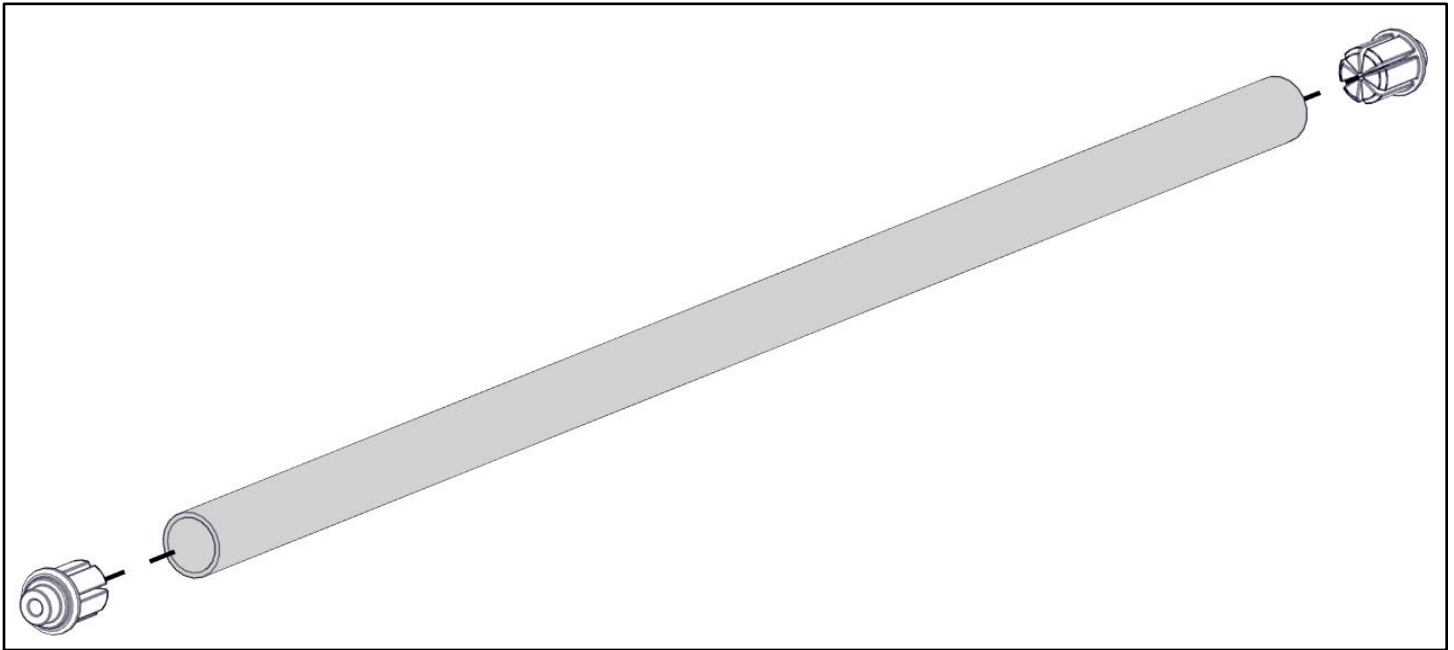

- Lay all pieces out in the orientation shown. Be sure to use the correct side channels as there is a driver and a passenger side.
- Use the cross members with the foot attachment bracket at the front and the rear of the side channels. The cross member without the bracket goes in the middle as shown.
- Place one end of each crossmember concentric with the bottom tube on each side channel section and cap using the clamps.
- Be sure the rear roller bar with the bushings is inserted into the rear of the side channels.

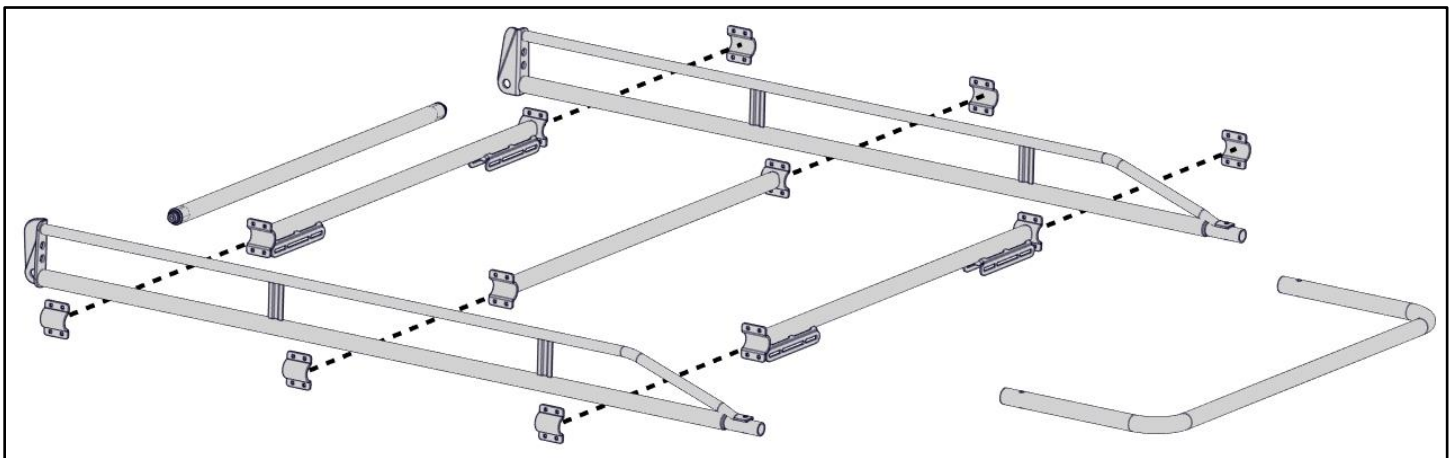

- Use the clamp to secure the cross member to the side channel using 5/16" x 1" carriage bolts, 5/16" flat washers and 5/16" lock nuts. **BE SURE TO HAVE THE ORIENTATION OF THE CARRIAGE BOLT AS SHOWN.** Repeat on all cross members and on both sides. Leave the clamps loose to allow back and forth adjustment for installation on the vehicle.
- Insert each side channel into the front hoop. Place sealant around the swage joint. Bolt together using 1/2" x 2-1/2" button head, two 1/2" flat washers and a 1/2" jam lock nut.
- Repeat on both sides

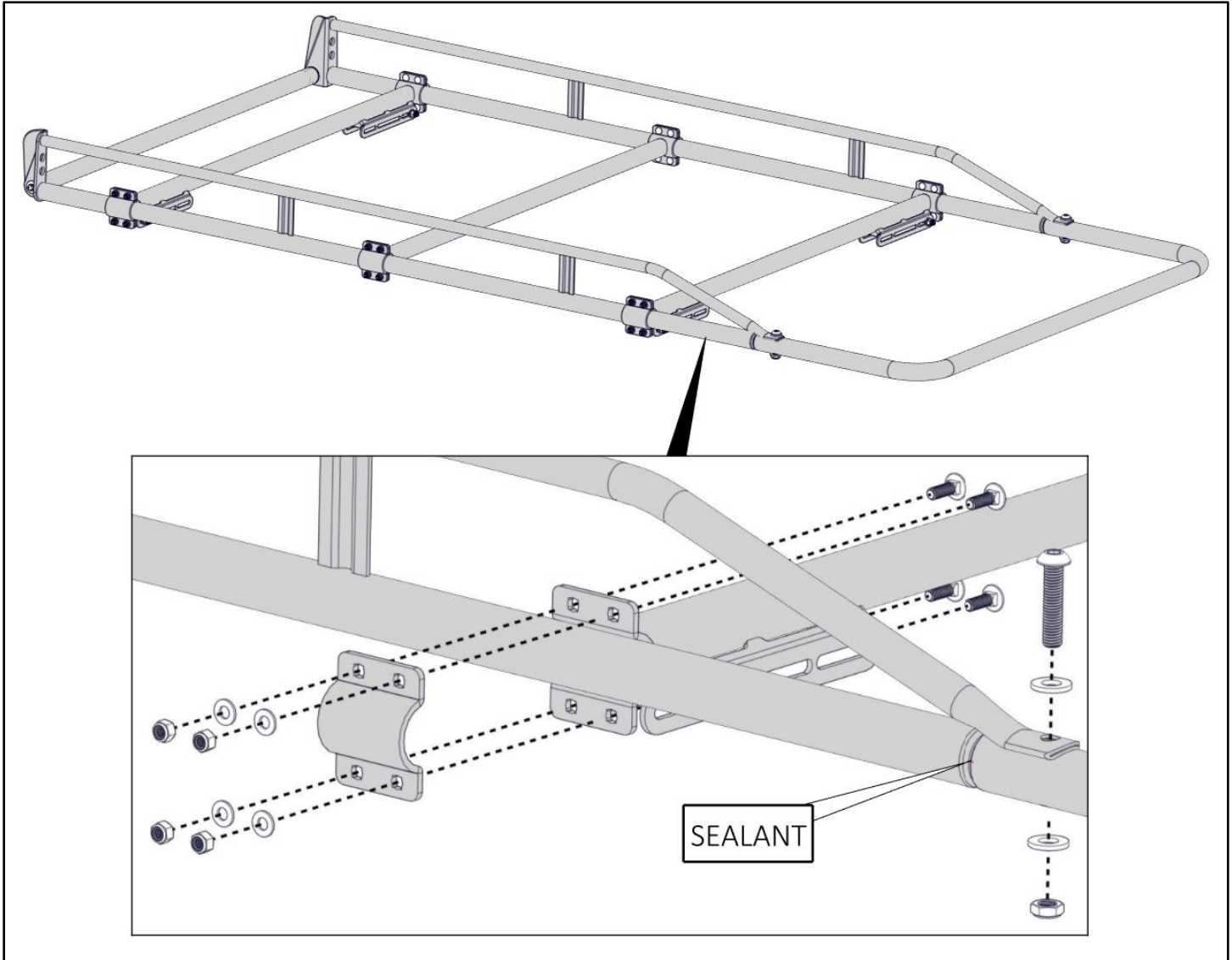

- Attach the rear roller bar to the side channels using a 3/8" x 2-1/2" hex and 3/8" oversize washer. **Tighten until the washer touches the bushing and no more.** The entire rear roller bar assembly, with bushing installed, is designed to roll.
- Repeat on both sides.
- Set to the side for future installation.

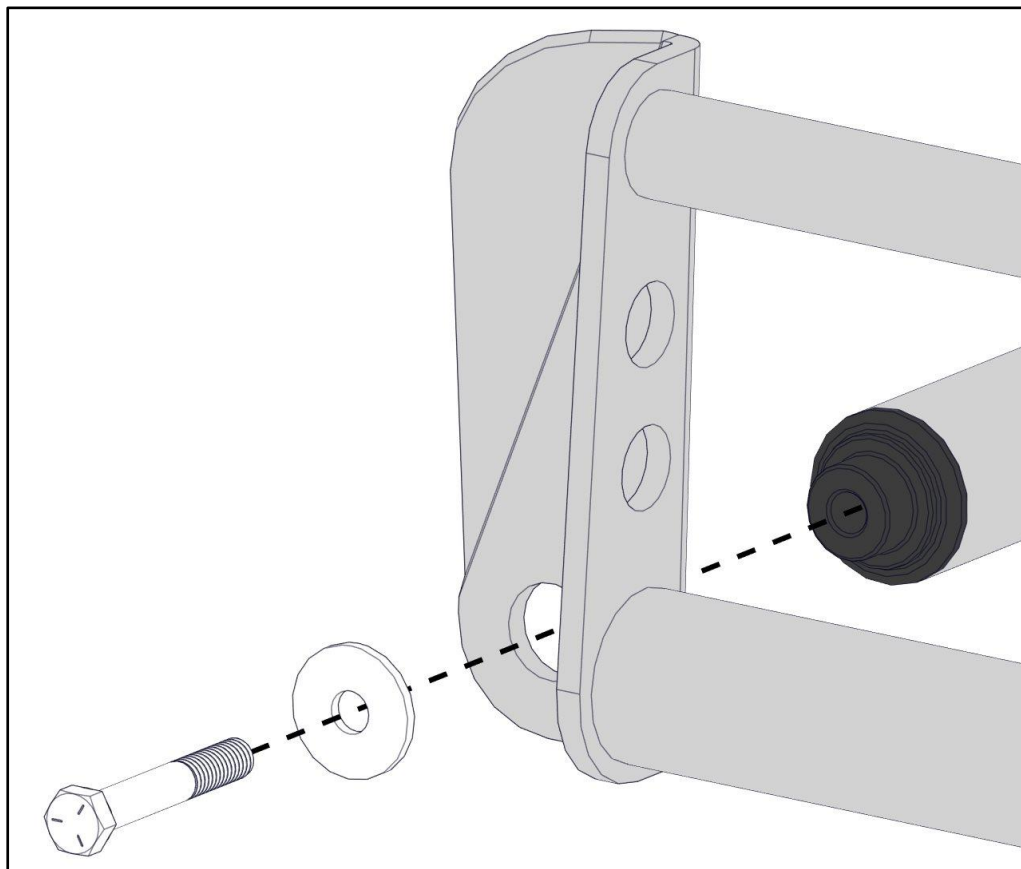
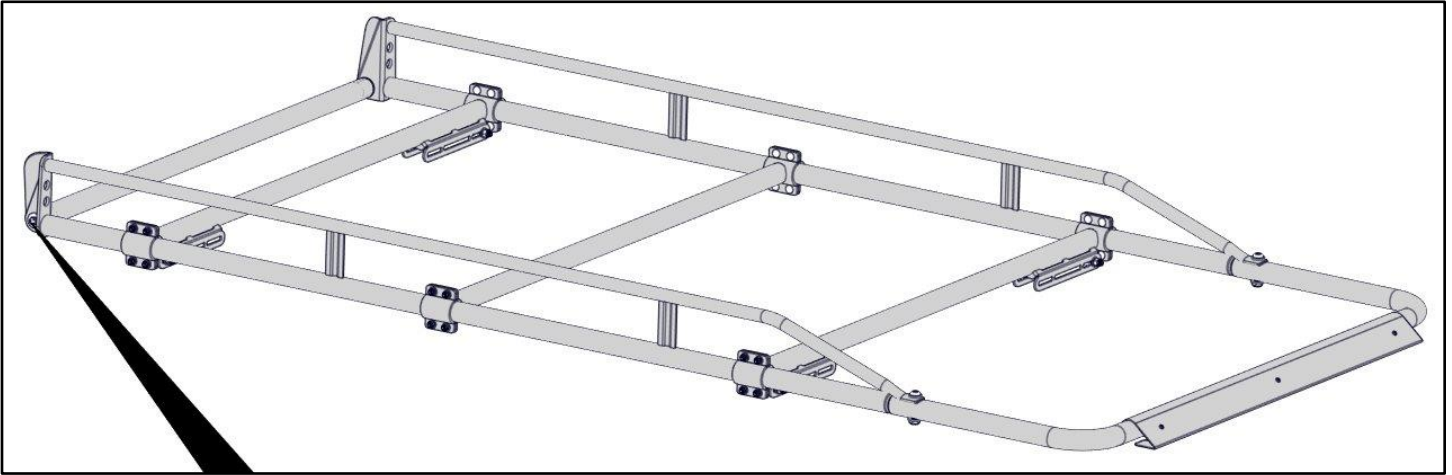

Find the vehicle specific mounting instructions in the following pages.

## Step 2A – Transit Connect

- Locate the plugs on the roof of the van in the locations shown. If desired, other locations can be used.
- Remove the plugs from the roof in ONLY the four desired mounting locations to expose the threaded inserts.
- Apply sealant around the threaded inserts in the roof. Place the three-hole rubber pad on top of the van with the center hole over the threaded insert. Be sure the sealant is applied to prevent water from leaking into the cargo area.
- Place the foot on top of the three-hole rubber pad with the cup of the foot facing outwards.
- Bolt through the foot into the threaded inserts using a M8 x 30mm hex head, a M8 flat washer, rectangular rubber pad on top of the roof, a round rubber washer on the inside of the vehicle, a fender washer and a M8 lock nut. The roof goes in between the two rubber pieces.
- Repeat at all four locations.
- Snug tighten, but allow movement.

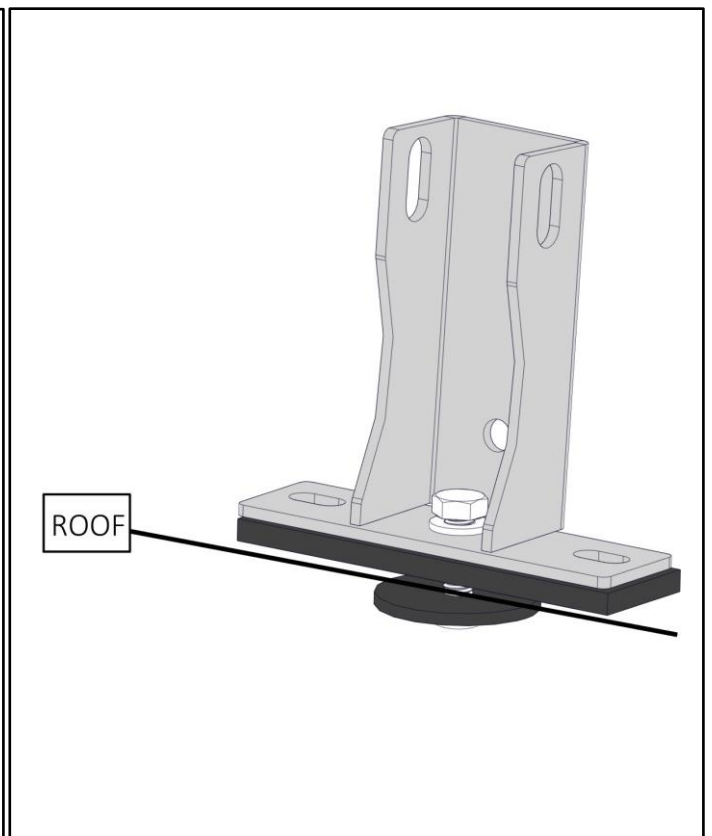
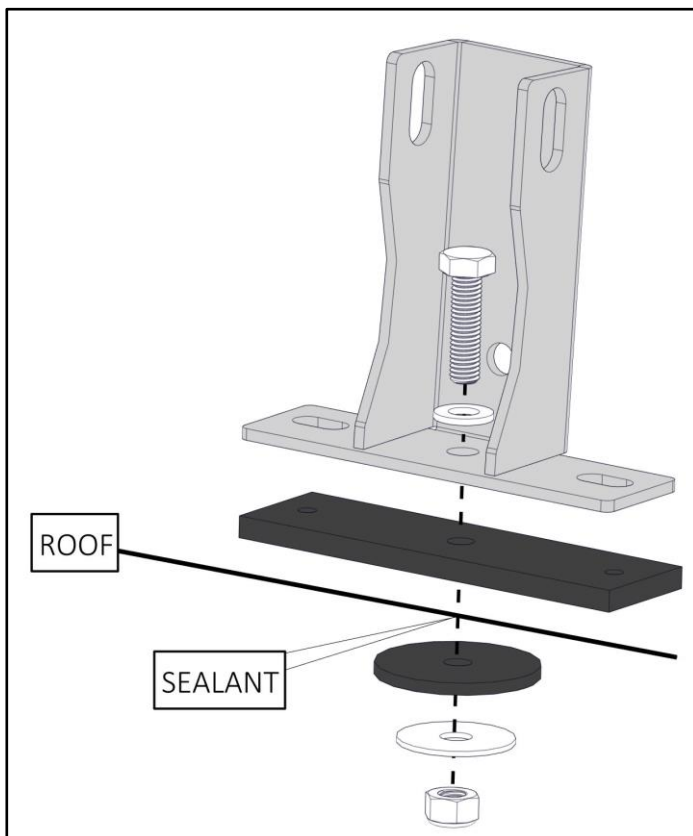
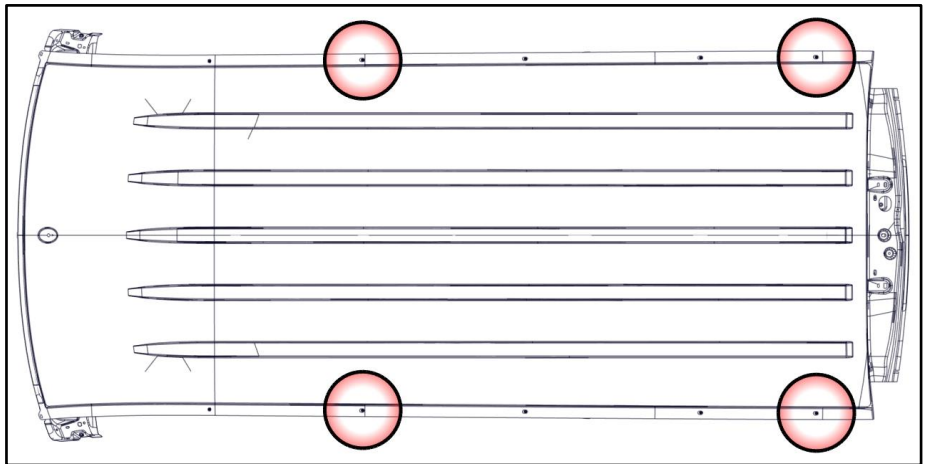

## Step 2B – Promaster City

- Remove the plugs from the roof in the mounting locations shown to expose the threaded inserts.

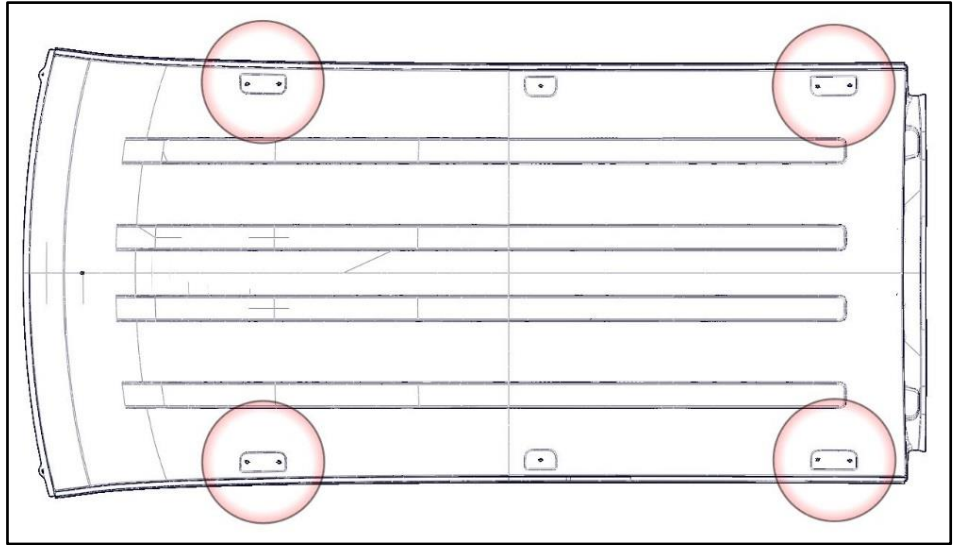

- Apply sealant around the threaded inserts in the roof. Place the two-hole rubber pad on top of the van with the center hole over the threaded insert. Be sure the sealant is applied to prevent water from leaking into the cargo area.
- Place the foot on top of the two-hole rubber pad with the cup of the foot facing outwards.
- Bolt through the foot into the threaded inserts in the roof using M6 x 20mm hex heads, M6 lock washers, M6 flat washers and a two-hole rubber pad in the order shown.
- Repeat at all four locations.
- Snug tighten, but allow movement.

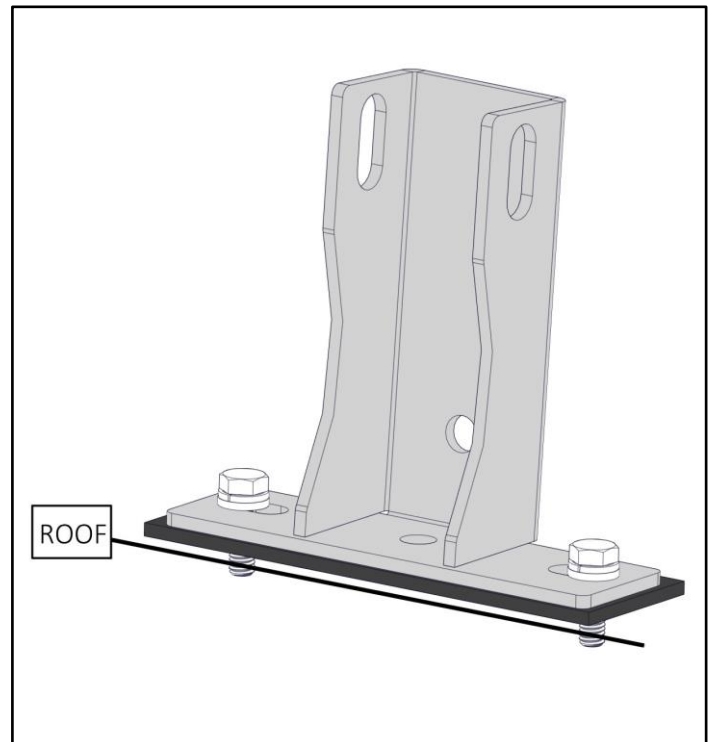
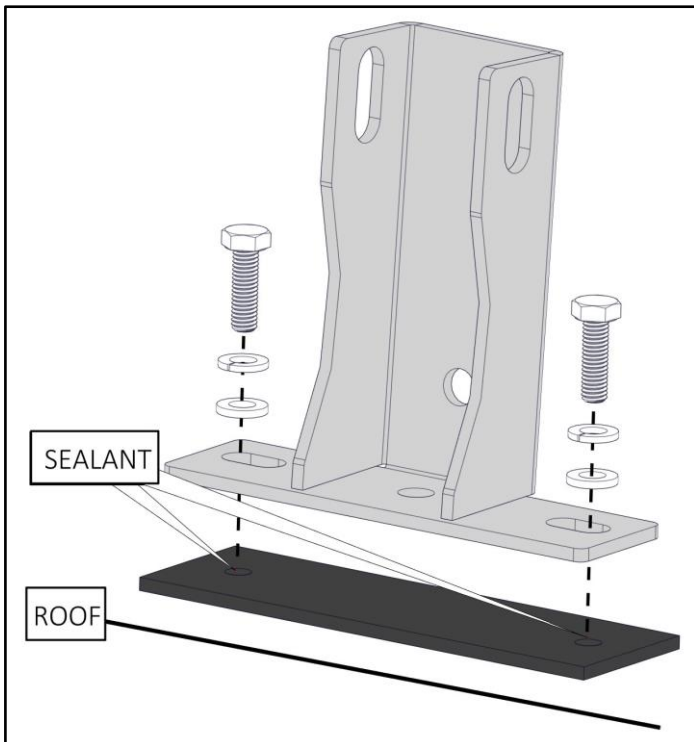

## Step 2C – NV200/City Express

- Remove the plugs from the roof in the mounting locations shown to expose the threaded inserts.

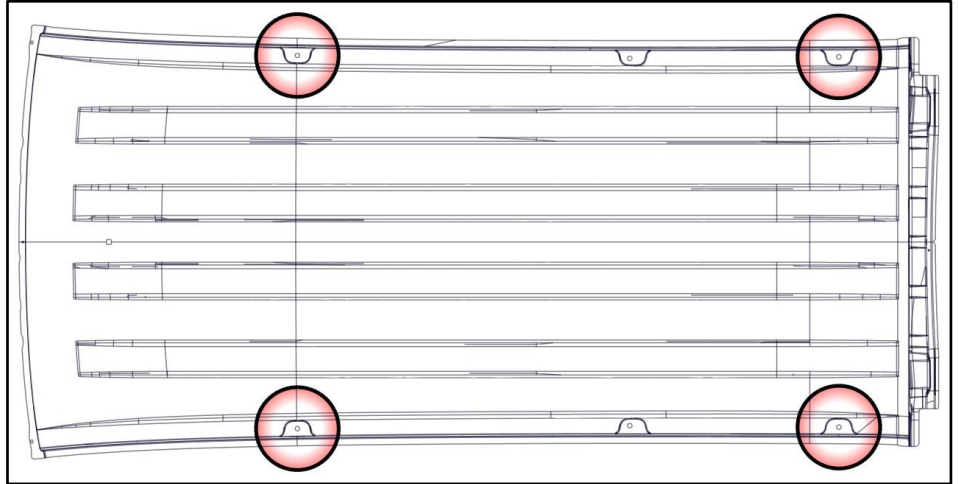

- Apply sealant around the threaded inserts in the roof.
- Place the three-hole rubber pad on top of the van with the center hole over the threaded insert. Be sure the sealant is applied to prevent water from leaking into the cargo area.
- Place the foot on top of the three-hole rubber pad with the cup of the foot facing outwards.
- Bolt through the foot into the threaded inserts using a M8 x 30mm hex head, M8 lock washer, M8 flat washer and a rubber pad in the order shown.
- Repeat at all four locations.
- Snug tighten, but allow movement.

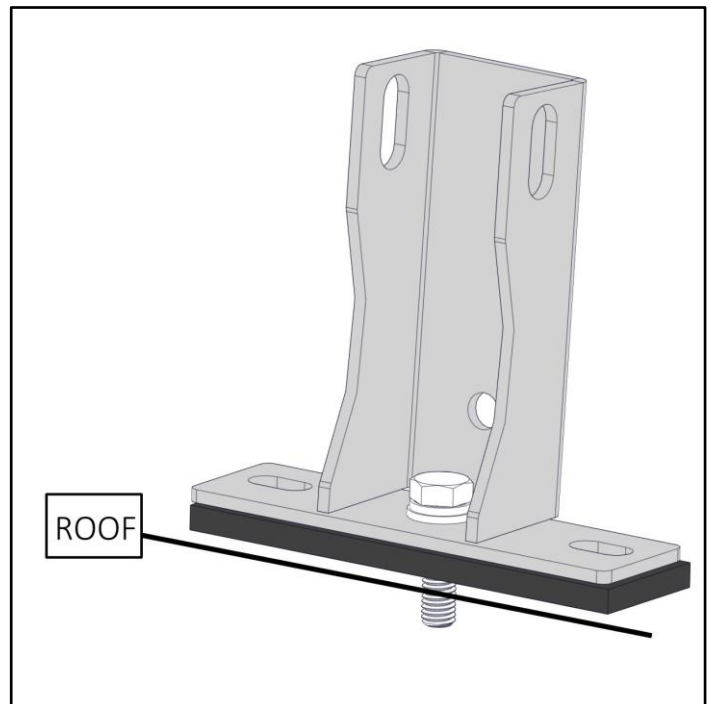
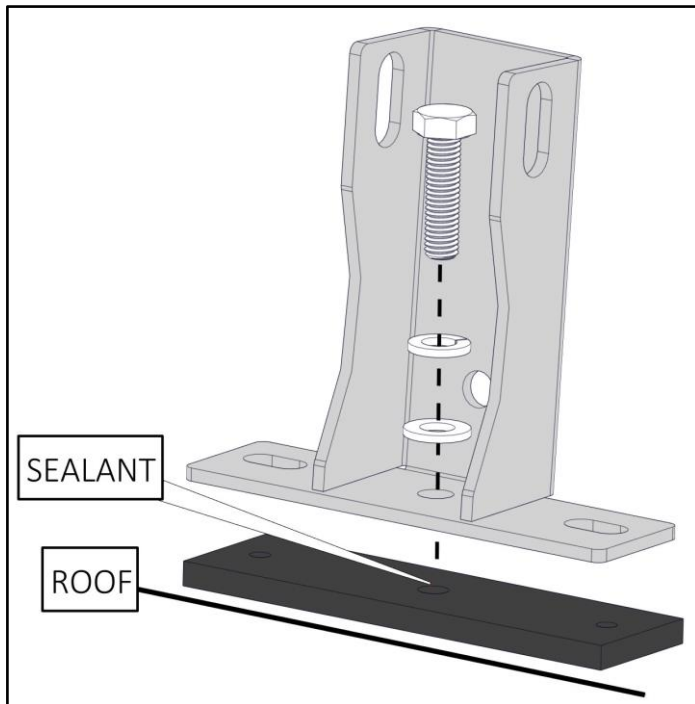

## Step 2D – Camper shell

- Find the desired ladder location on top of camper shell. Some caps will have reinforced mounting locations built into the cap.
  - \*\*This step may be easier if the feet are installed on the rack\*\***
- Place the feet on top of the camper shell in the desired location.
- Mark through the slots in the feet onto the top of the camper shell.
- Ensure the marked location is safe to drill. Drill the center of each slot using a 5/16" drill.
- Apply sealant around the exposed holes in the cap to help prevent water from leaking into the cargo area.
- Place a two or three-hole rubber pad on top of the holes in the cap.
- Place the foot on top of the rubber pad.
- Bolt through the foot, the rubber pad and the camper shell using two M8 x 60mm hex heads and two M8 flat washers.
- From the inside of the camper shell, place the two or three-hole rubber pad over the previously installed bolts and up against the inner side of the camper shell. Put some sealant around the holes of the rubber pad.
- Place the metal plate against the rubber pad, followed by two M8 flat washers and two M8 lock nuts.
- Repeat at all four locations.
- Snug tighten, but allow movement.

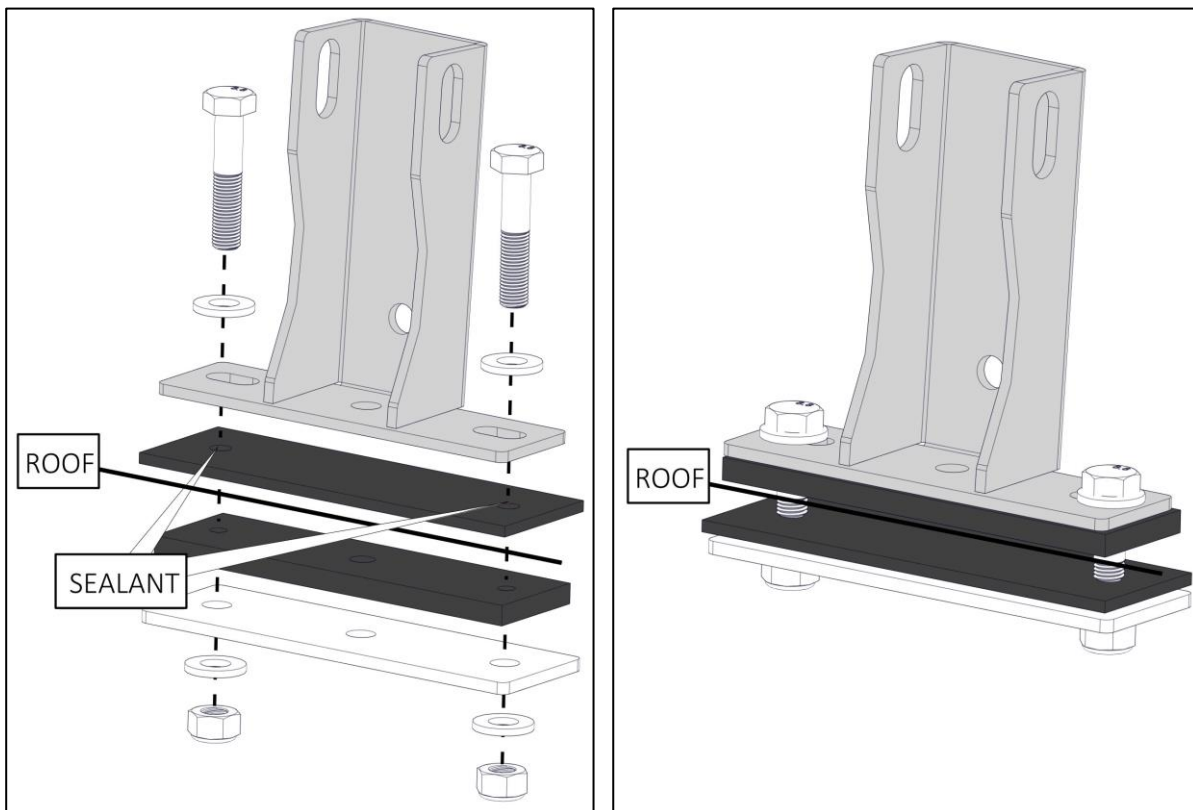

### Step 3 – Mount Crossbars to Feet

- Measure the distance between the previously installed feet. Adjust the crossbars with the foot mount to closely match this distance.

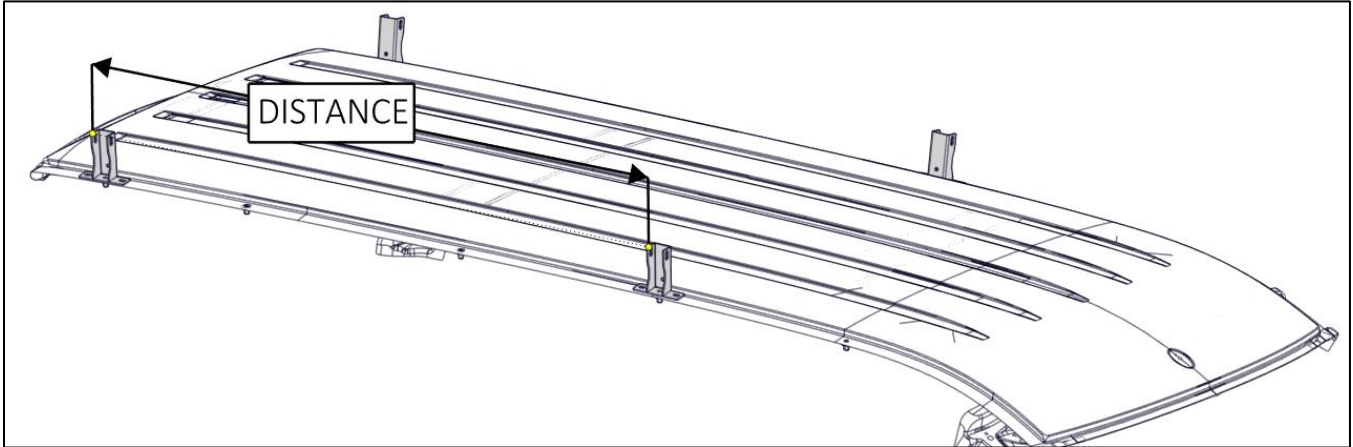

- Place the rack on top of the previously installed feet.
- Have the rear roller bar hanging off the rear of the vehicle enough so that when placing a ladder on the rack it does not come into contact with the rear of the vehicle.

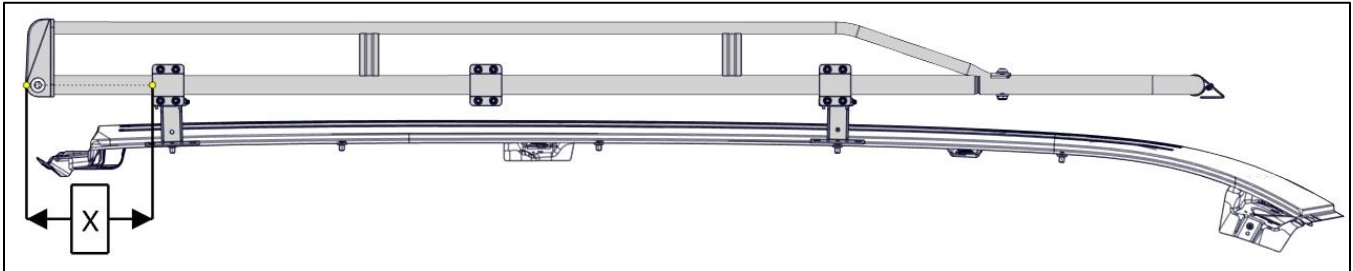

- Bolt the feet to the crossbar using a 3/8" x 3" hex head bolt, two 3/8" flat washers, a 3/8" x 1-1/2" spacer and a 3/8" nyloc nut in the orientation shown below.
- The spacer goes to the inside of the foot.

**\*Shown without the rack for clarity\***

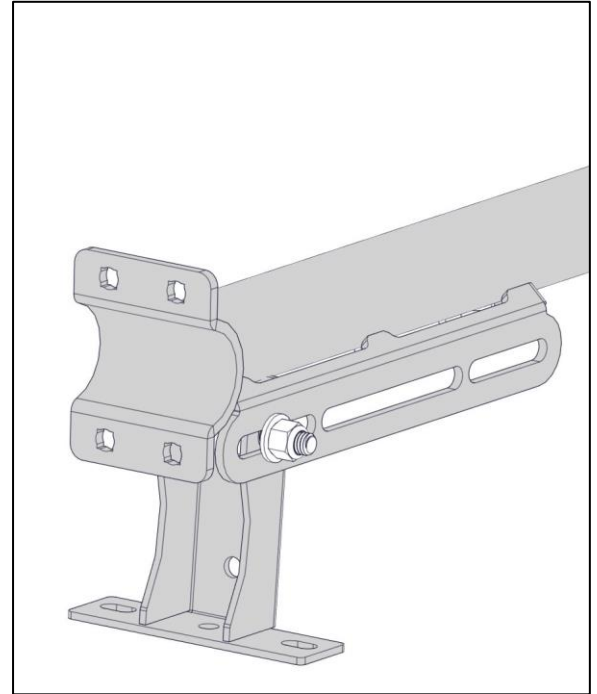
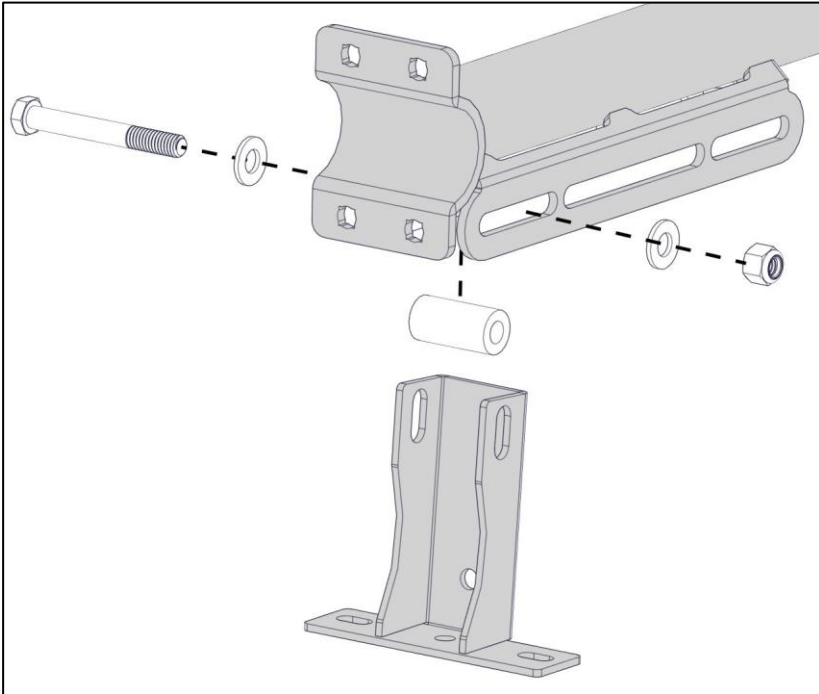

- Repeat at all four locations.
- Snug tighten, but allow movement.

**\*Shown without the rack for clarity\***

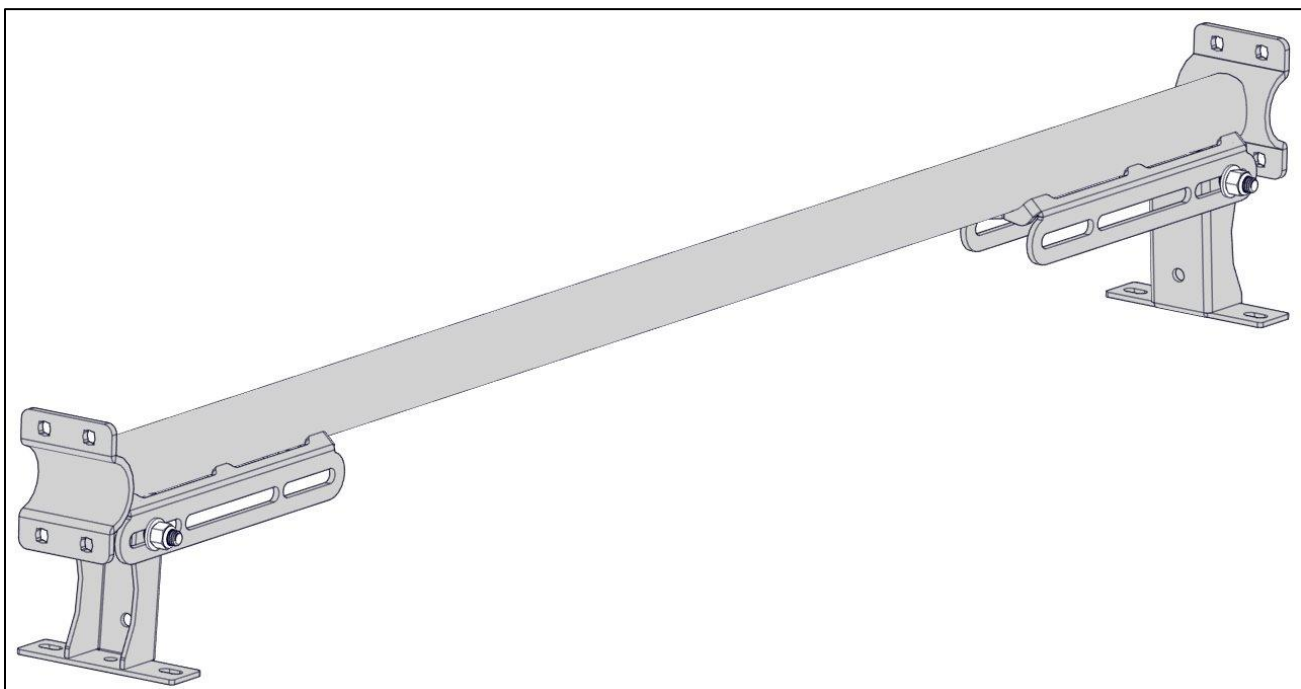

## Step 4 – Wind Deflector

- Place the wind deflector around the front tube in the orientation shown.

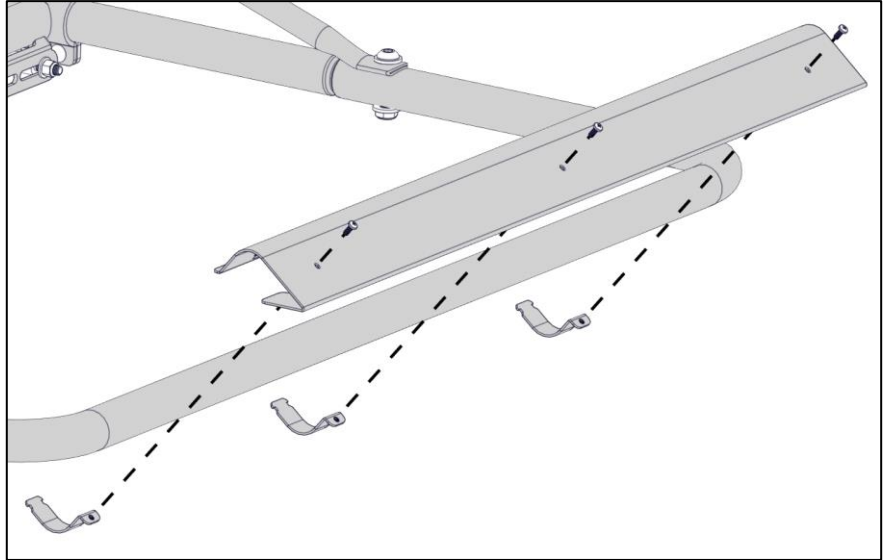

- Place the clamp around the front tube and position the clamp so it hooks into the wind deflector.
- Attach the clamp to wind deflector using #10 x 1/2" pan head screw.
- TIGHTEN pan head screws.
- Repeat for a total of 3 times.
- This wind deflector can be adjusted to minimize wind noise.

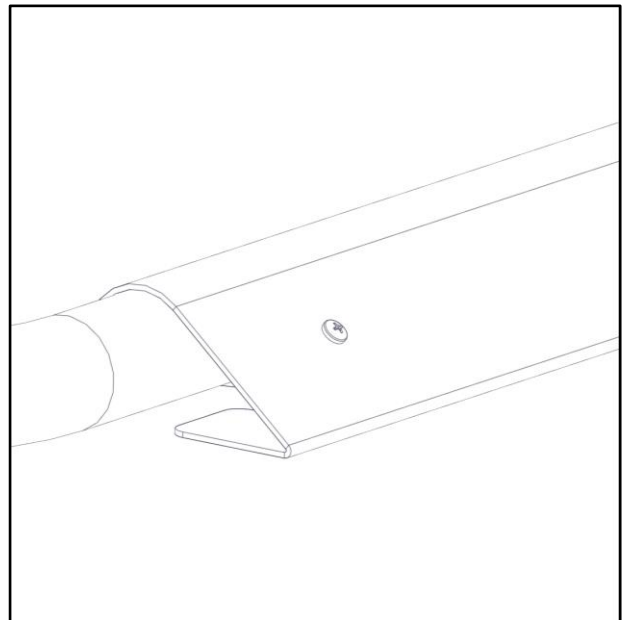
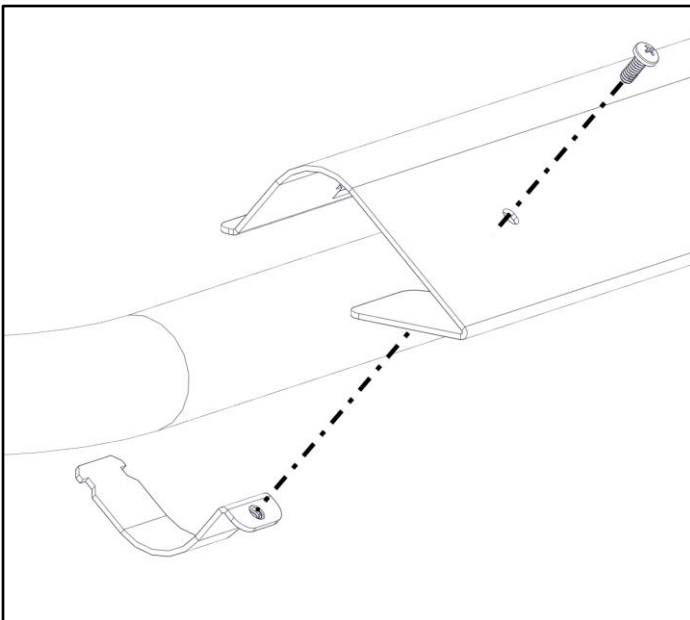
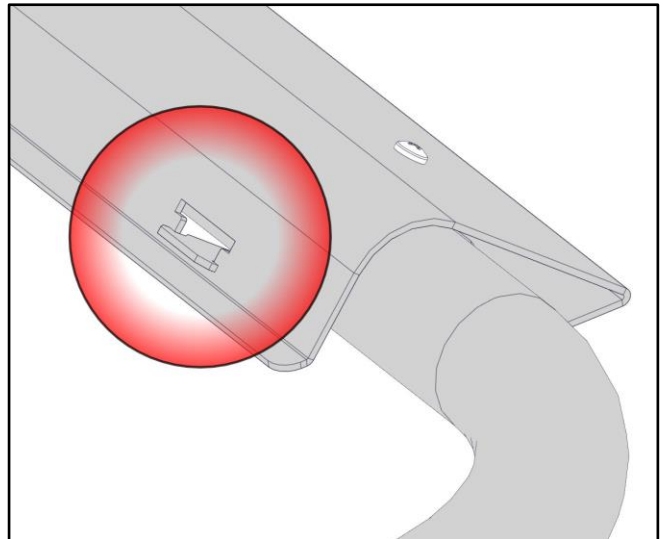

GO BACK AND MAKE SURE ALL HARDWARE IS TIGHT

START BY TIGHTENING THE FEET TO THE VEHICLE AND MOVING UPWARD  
AND OUTWARD ON THE RACK

YOUR INSTALLATION IS NOW COMPLETE

