

KARGO MASTER[®]

WE PUT EVERYTHING WITHIN REACH.

Instruction Guide

4A934

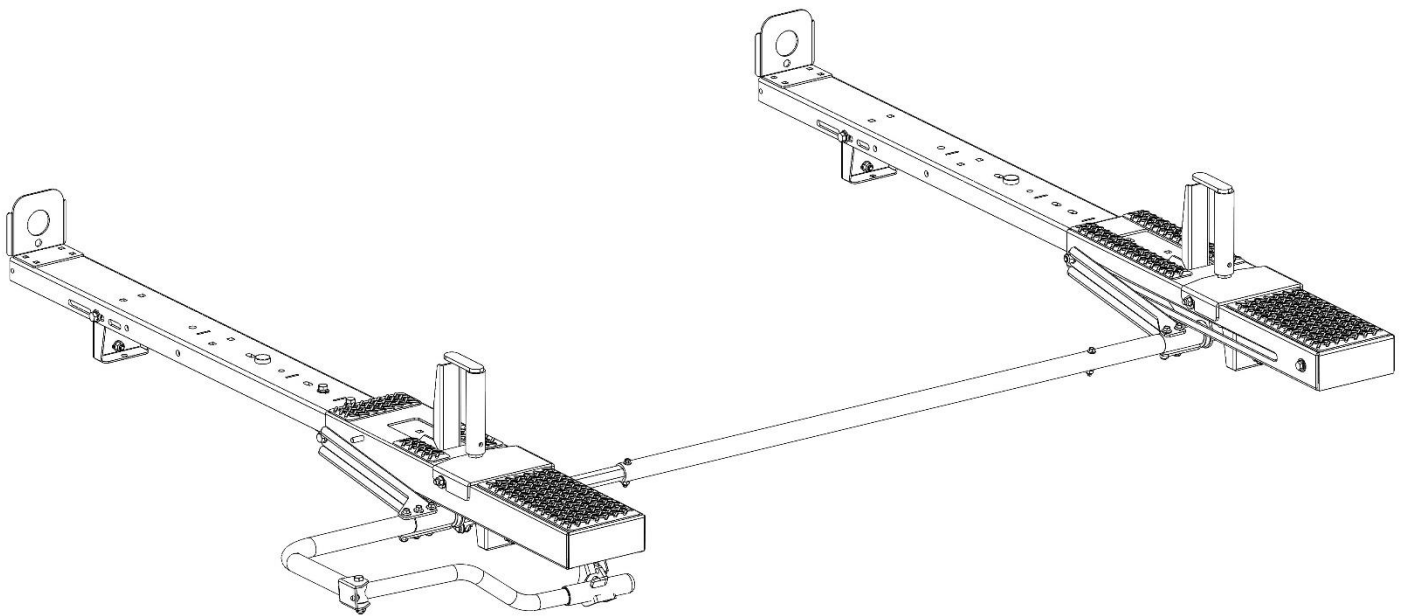

PLEASE READ ALL INSTRUCTIONS AND WARNINGS PRIOR TO ASSEMBLING, INSTALLING, AND USING THIS PRODUCT.

Warning



Always check for wires, fuel tanks and lines, brake lines and other important vehicle functionality items prior to drilling and installing all products.



DO NOT EXCEED MANUFACTURERS WEIGHT CAPACITY FOR ROOF.

Tools Needed

13mm Socket and Wrench	10mm Socket and Wrench
5mm Allen Hex	9/16" Socket and Wrench
1/2" Socket and Wrench	

Table of Contents

Parts List..... 2

Hardware 3

Step 1 – Assemble Feet 4

Step 2 – Install End Stop 5

Step 3 – Identify Front and Rear Bow. 5

Step 4 – Mount Rack 6

Step 5 – Hex Tube Adjustment 6

Step 6 – Install Hex Tube..... 7

Step 7 – Install Latch 8

Step 8 – Install Handle..... 8

Step 9 – Install Ladder Stop 9







Step 10 – Assemble Ladder Hooks 9

Step 11 – Install Ladder Hooks 10

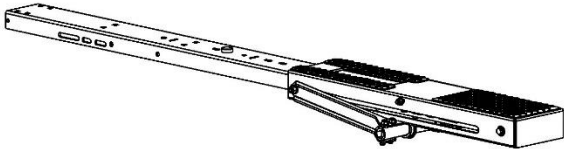
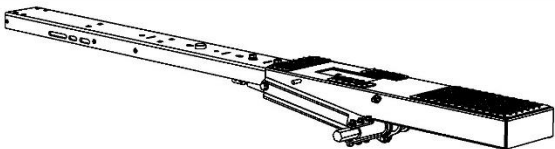

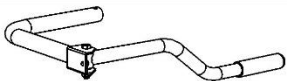
Before You Begin

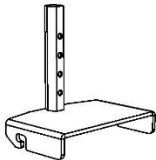
- To install on a truck cap, 408SC mounting kit is required.
- Read all instructions.
- Find your truck cap roof mounting locations prior to rack assembly.
- Be sure to put sealant around all threads entering cargo area and between the rubber spacer and roof of vehicle to prevent water from leaking into cargo area.
- The standard distance between the front and rear bow is 71.5". This can vary, but be sure the rack can be assembled prior to installing mounts on vehicle.
- **PLACE ANTI-SEIZE ON ALL THREADS.**

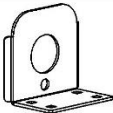
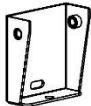
Parts List

ITEM NO.		PART NUMBER	DESCRIPTION	QTY.
1		4A933-FRONT-ALUM	FRONT BOW ASSEMBLY	1
2		4A933-REAR-ALUM	REAR BOW ASSEMBLY	1
3		4A900-20	HEX TUBE ASSEMBLY	1
4		4A933-47	HANDLE ASSEMBLY	1
5		4A92L-44-R1	LATCH ASSY.	1
6		4A900-35	LADDER HOOK ASSEMBLY	2
7		4A900-36	BASE LADDER HOOK WELDMENT	2
8		4A900-30-004-R3	LADDER STOP	2
9		4A900-10-008	END STOP	2
10		4A800-10	FOOT ASM	4
11		18-4A934	HARDWARE KIT	

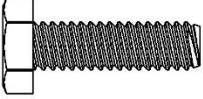
Hardware

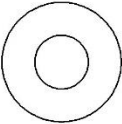
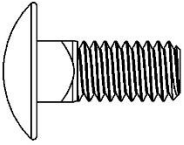
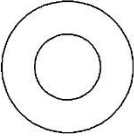
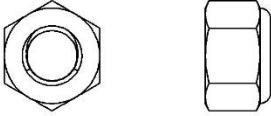
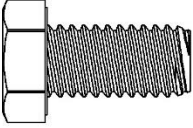
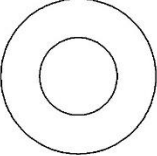
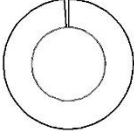
ITEM	HARDWARE TO SCALE	PART NUMBER	DESCRIPTION	QTY.
1		92865A541	1/4"-20 X 7/8" HEX BOLT	2
2		GRADE SAE	1/4" LOCK WASHER	2
3		90126A029	1/4" FLAT WASHER	2
4		90185A581	5/16"-18 X 3/4" CARRIAGE BOLT	6
5		90126A030	5/16" FLAT WASHER	6
6		95615A160	5/16"-18 LOCK NUT	6
7		GRADE 5	3/8"-16 X 3/4" HEX HEAD BOLT	8
8		96659A108	3/8" FLAT WASHER	8
9		92146A031	3/8" SPLIT LOCK WASHER	8
10		DEFAULT	SEALANT	1

DO NOT EXCEED MANUFACTURERS WEIGHT CAPACITY FOR ROOF

Step 1 – Assemble Feet

- Measure width between installed mounts on vehicle.
- On the cross bows, use the slots that correspond to the measured distance between the mounts.
- Bolt feet to bows as shown, DO NOT TIGHTEN at this point.
- Most common orientation is with the opening in the foot toward the center of the van
- Use a 3/8" x 3/4" hex head bolt, 3/8" lock washers and a 3/8" flat washer to bolt foot to cross member.
- Snug tighten, but allow movement.

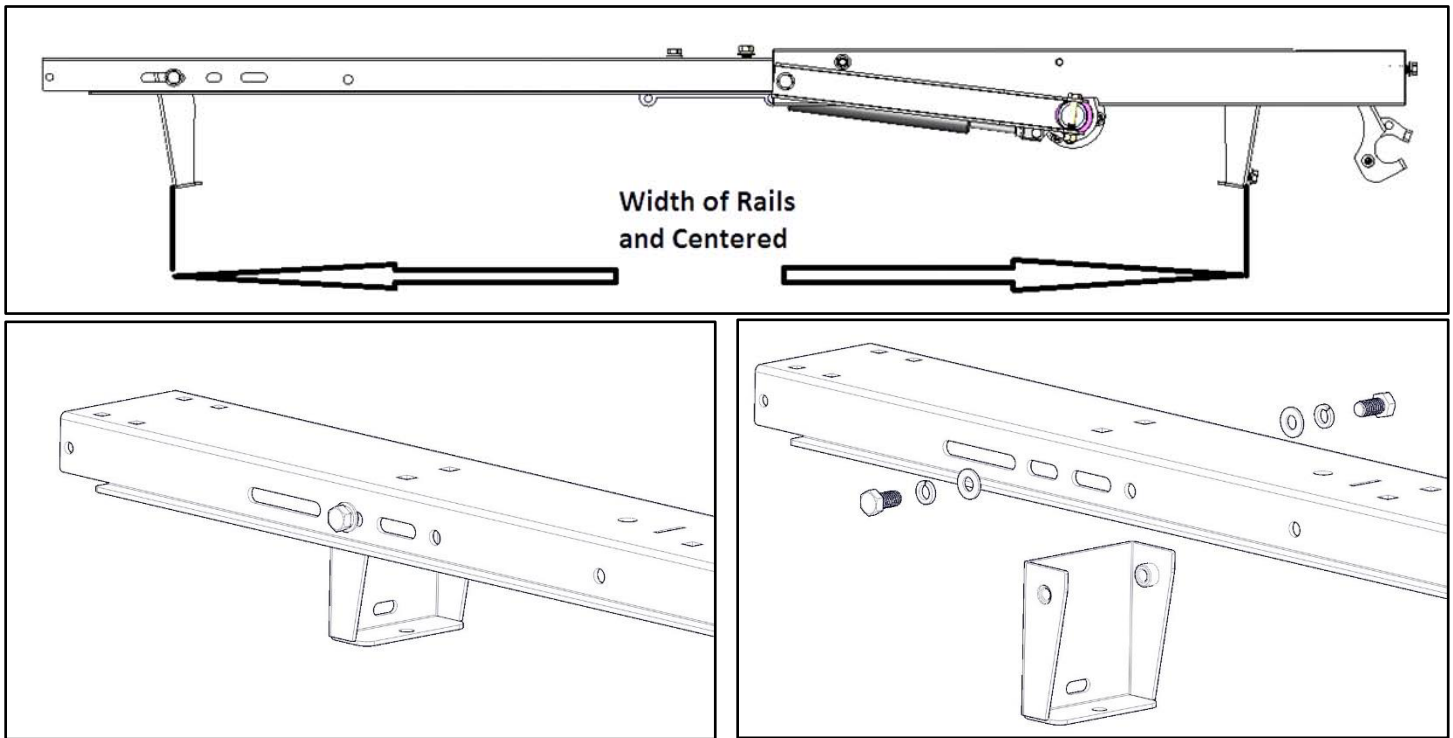

Step 2 – Install End Stop

NOTE: Skip the following end stop installation instructions if adding 4A943 to the drivers side.

- Using two 5/16" carriage bolts, two 5/16" washers and two 5/16" lock nuts, bolt the end stop to the exposed end of each bow as shown below.
- TIGHTEN nuts.

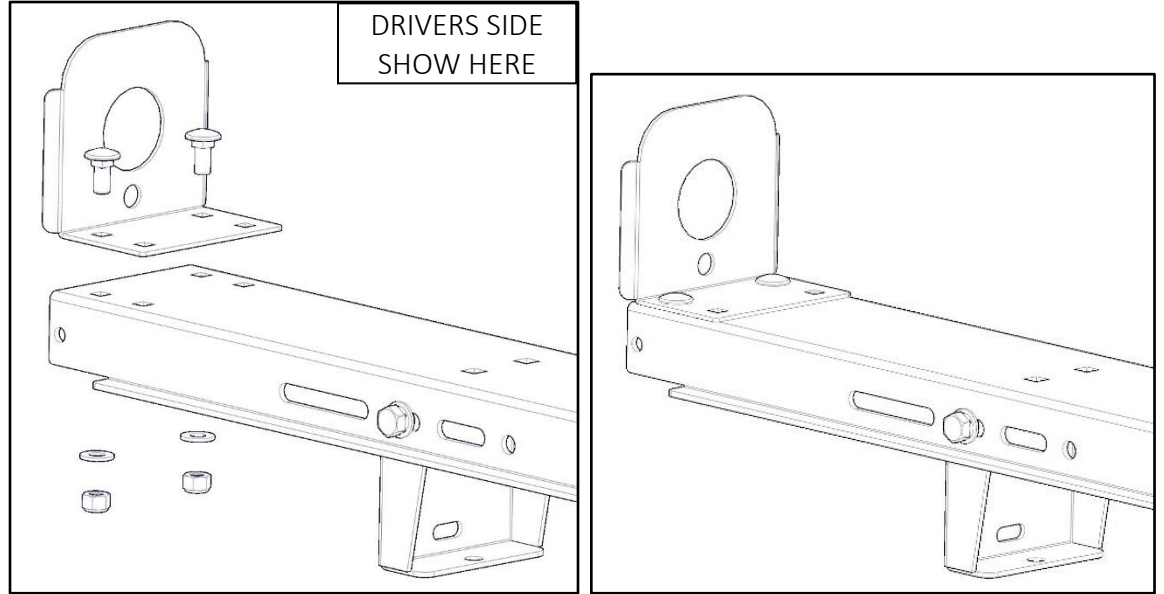

Step 3 – Identify Front and Rear Bow.

- The front bow will have a slot in the pan.

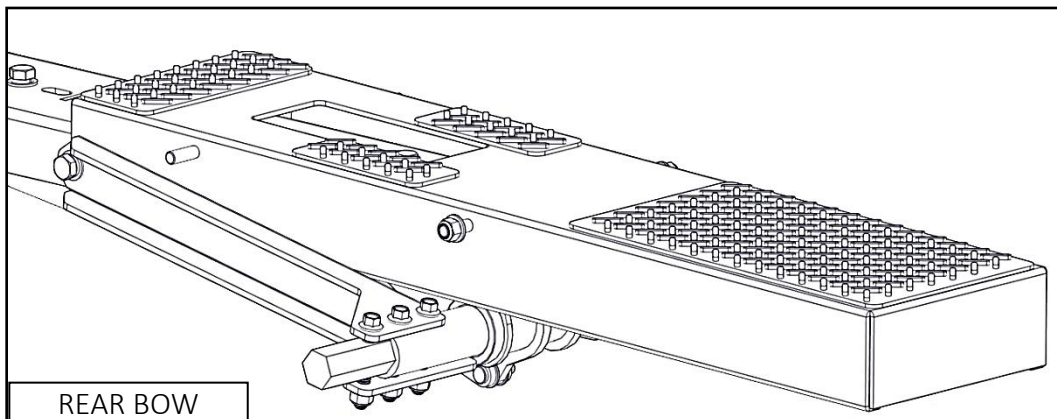
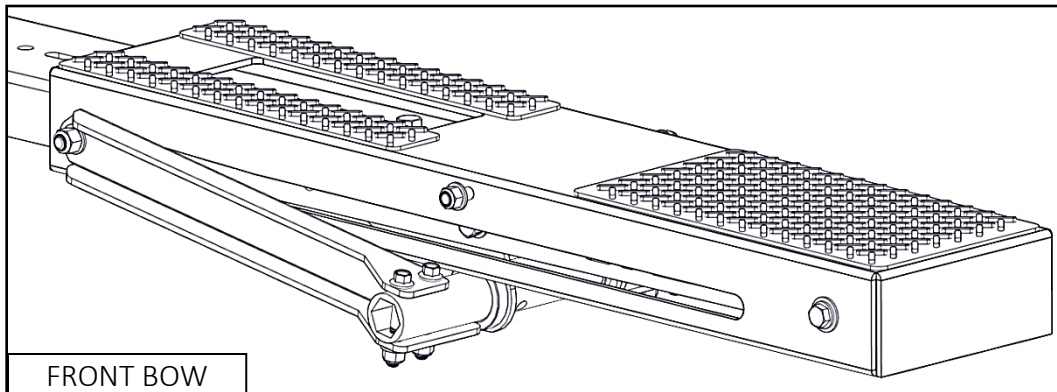

Step 4 – Mount Rack

- Place both bows on top of installed brackets.
- Bolt feet to brackets using 5/16" carriage bolt, 5/16" flat washers and a 5/16" lock nut.
- Be sure to have the front bow in the front of the vehicle.
- Put the ladder hooks on the driver side of vehicle.
- Snug tighten, but allow movement.

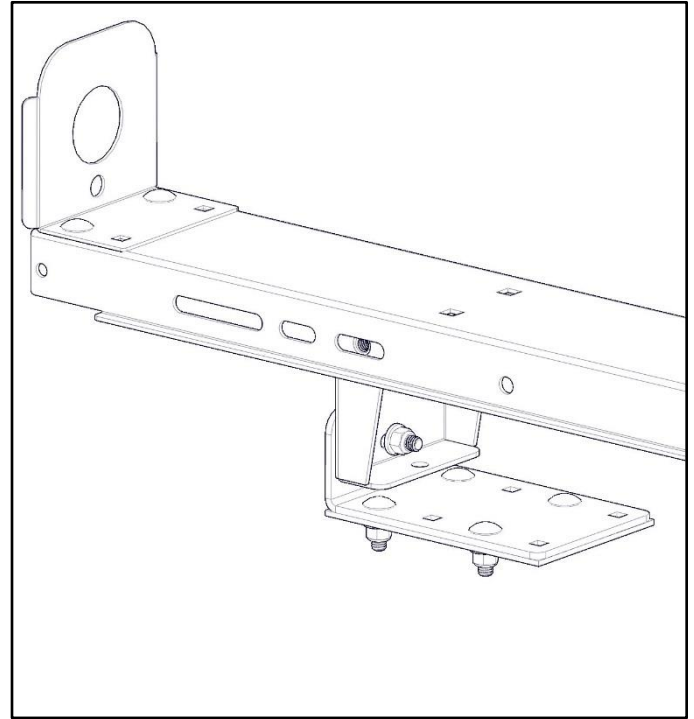
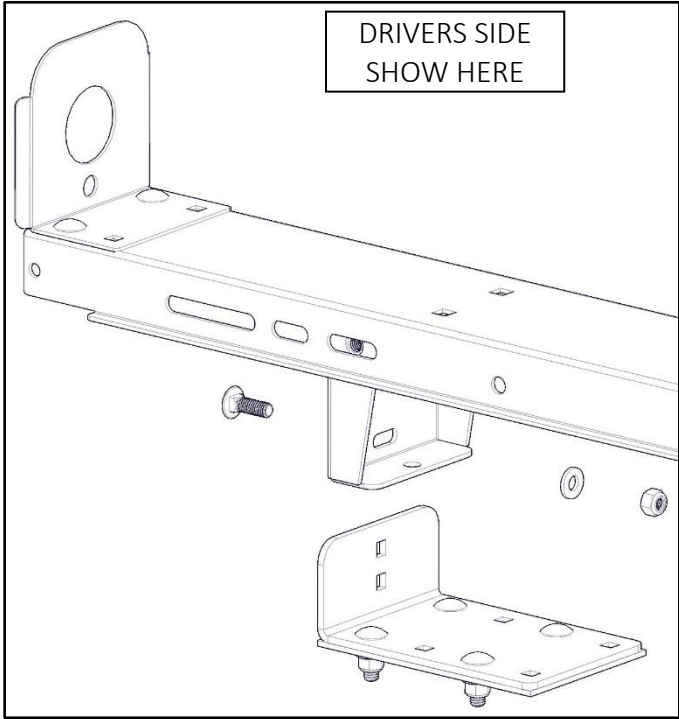

Step 5 – Hex Tube Adjustment

- Remove bolts in hex tube assembly to allow adjustability.

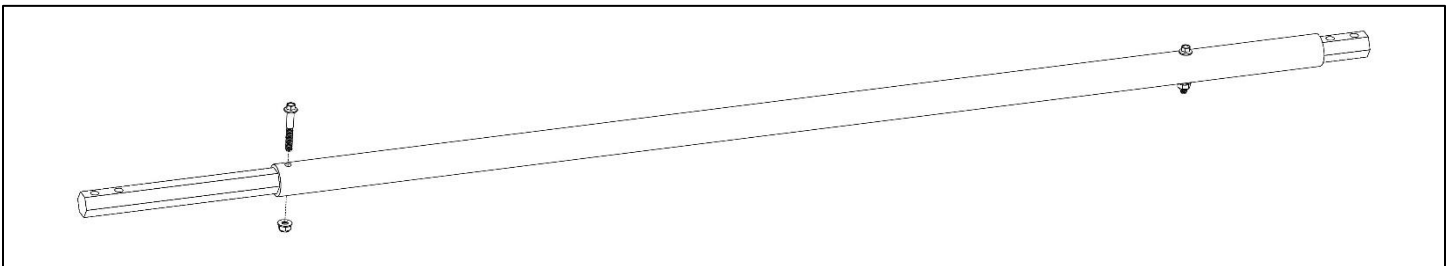

Step 6 – Install Hex Tube

- Remove the 5/16" x 2" flanged head screws, 5/16" washers, and 5/16" lock nuts from the front bow as shown below.
- Align the hex tube assembly so the holes in the hexagonal bar line up with holes in front pan receiver.
- Insert hex tube into receiver tube in front pan assembly.
- Insert 5/16" x 2" flanged head screws through front pan receiver with hex tube and fasten 5/16" washers and 5/16" lock nuts to screws.

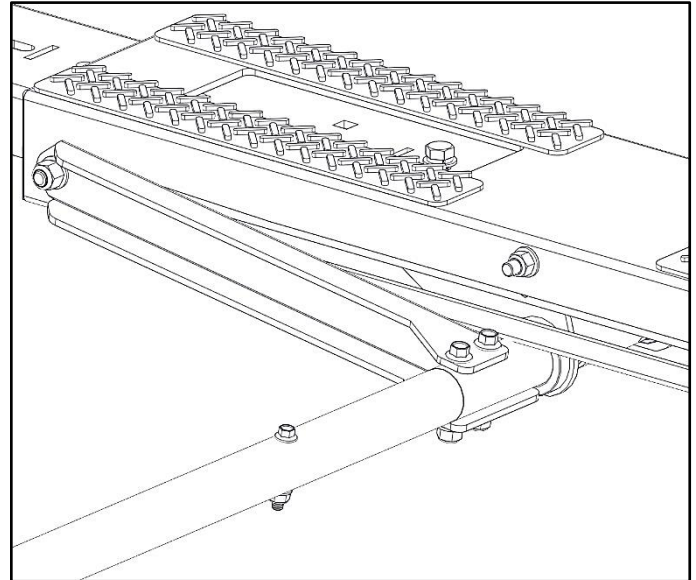
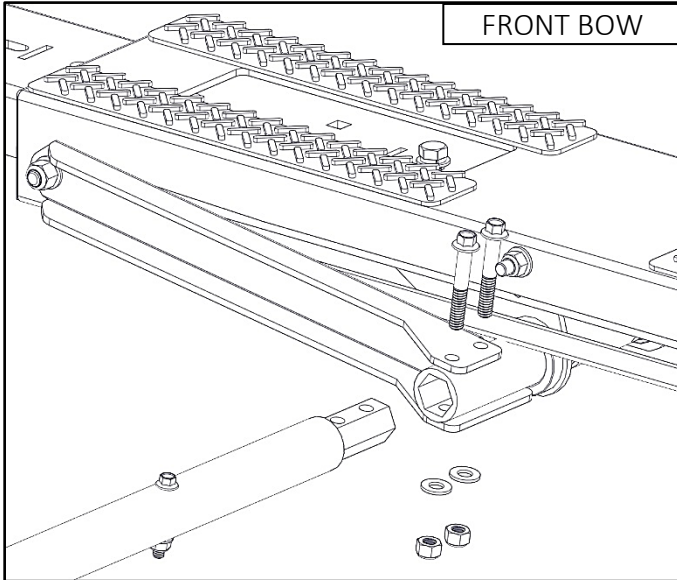

- Remove the 5/16" x 2" flanged head screws, 5/16" washers, and 5/16" lock nuts from the rear bow as shown below.
- Align the hex tube assembly so that exposed holes line up with holes in rear pan receiver.
- Insert hex tube into receiver tube in front pan assembly.
- Insert 5/16" x 2" flanged head screws through front pan receiver with hex tube and fasten 5/16" washers and 5/16" lock nuts to screws.
- TIGHTEN all bolts on both front and rear bows.

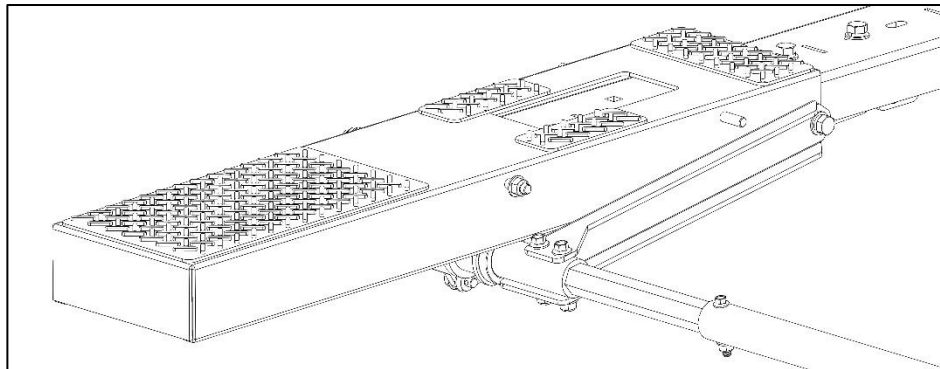
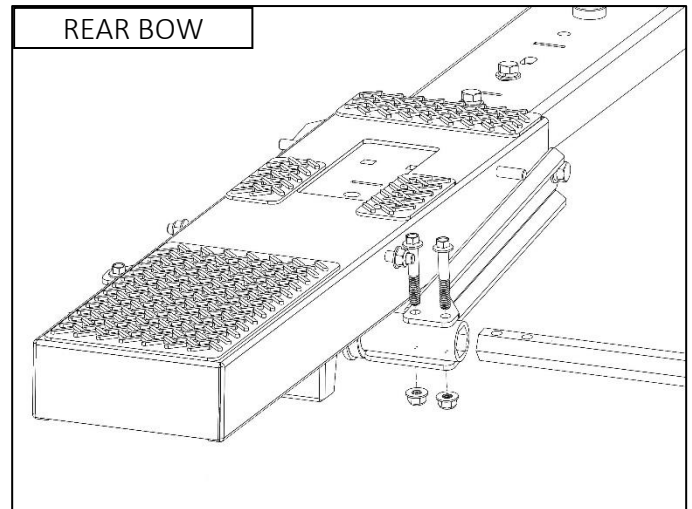

Step 7 – Install Latch

- Move rear pan assembly out of the way to expose the end of the cross member.
- Bolt through the inside most set of square holes as shown.
- Bolt latch assembly to end of cross member using 5/16" x 3/4" carriage bolts, 5/16" flat washers and 5/16" lock nuts.
- Shown without pan for clarity.
- TIGHTEN bolts and nuts.

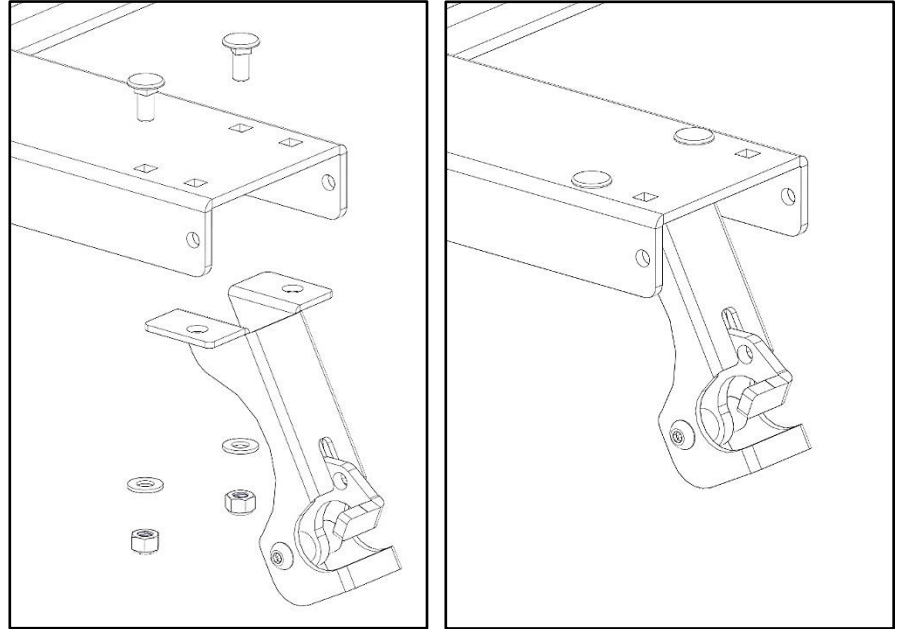

Step 8 – Install Handle

- Remove the 5/16" x 2" flanged head screw, 5/16" washer, and 5/16" lock nut from front bow as shown.
- Align the handle tube so holes in the hexagonal bar and handle tube line up.
- Insert handle tube onto hex tube and fasten using 5/16" x 2" flanged head screw, 5/16" washer, and 5/16" lock nut.
- TIGHTEN bolts and nuts.

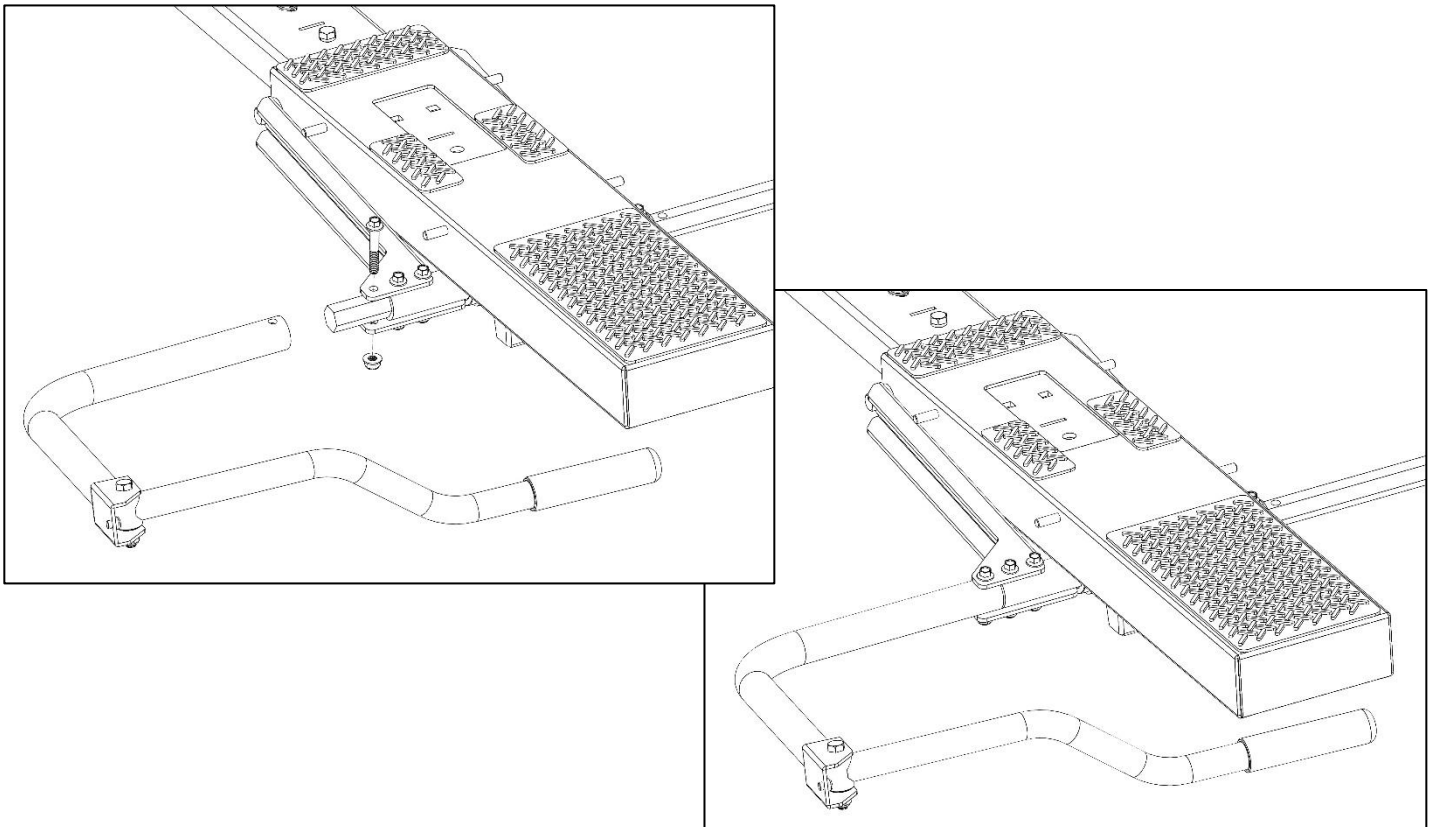

Step 9 – Install Ladder Stop

- Using the hardware in both bows, bolt ladder stop in orientation shown. Be sure to place the tab on the ladder stop into the slot on the bow.
- Ladder stop may be installed on other set of PEM studs, closer to the center of the vehicle if desired.
- TIGHTEN hardware.

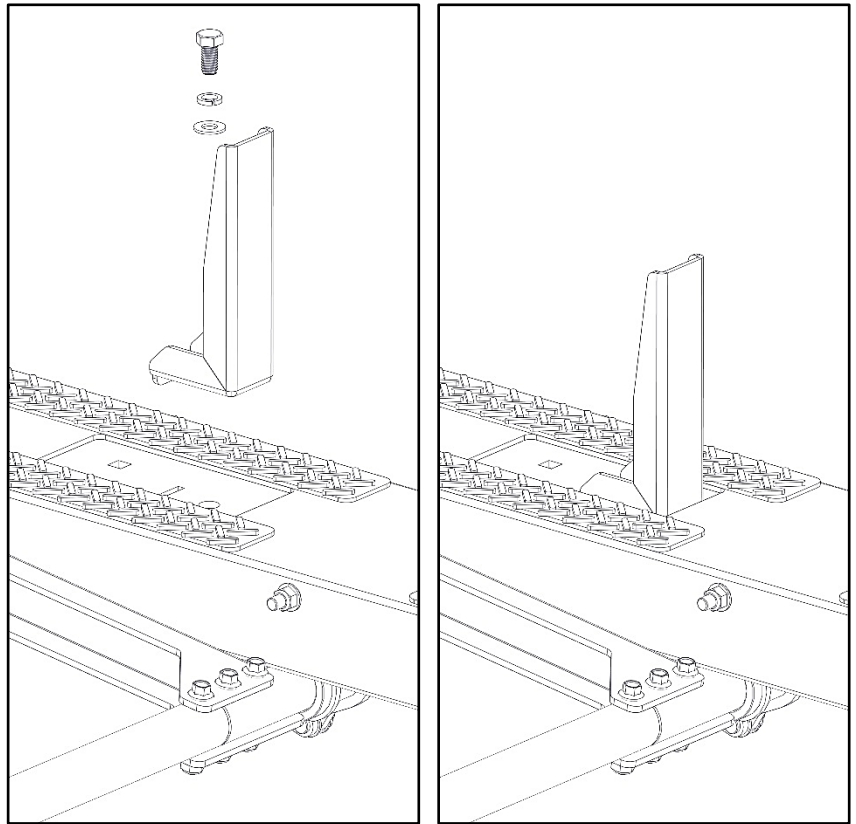

Step 10 – Assemble Ladder Hooks

- Using one 1/4" x 7/8" hex head, one 1/4" lock washer, and one 1/4" flat washer, fasten ladder hook assembly to ladder hook weldment as shown.
- TIGHTEN lock nuts.
- Repeat for second ladder hook.

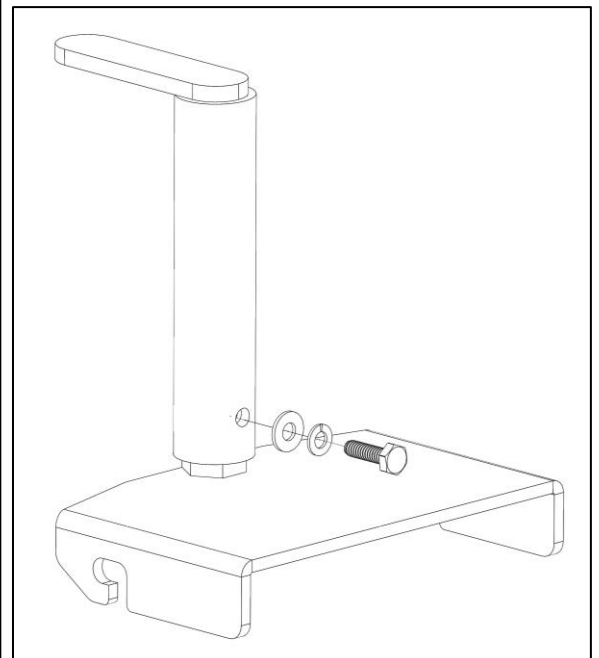
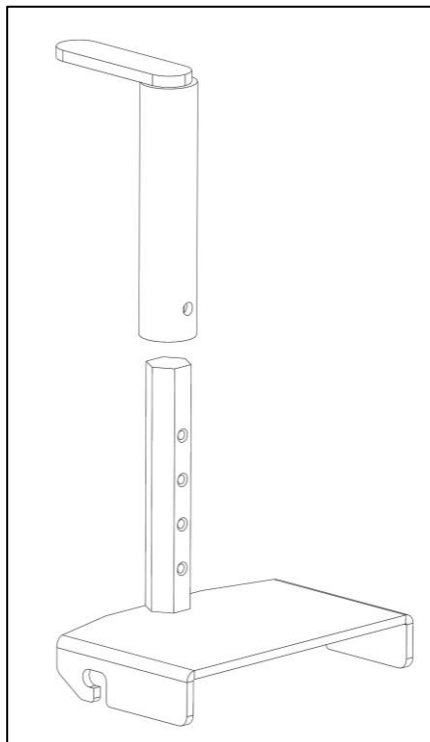

Step 11 – Install Ladder Hooks

- Using the installed studs and lock nuts on both bows, loosen nuts and slide ladder hook assembly into place.
- TIGHTEN lock nuts.

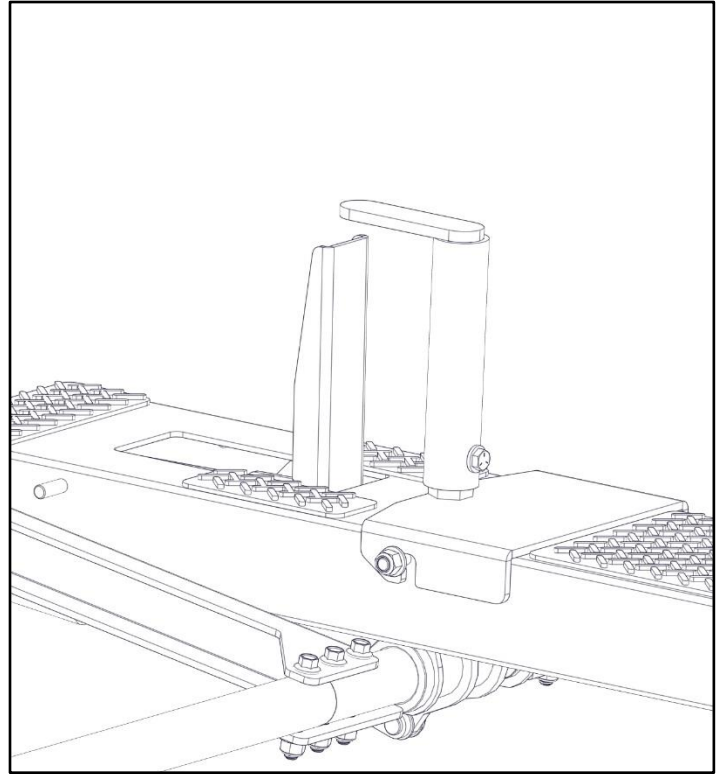
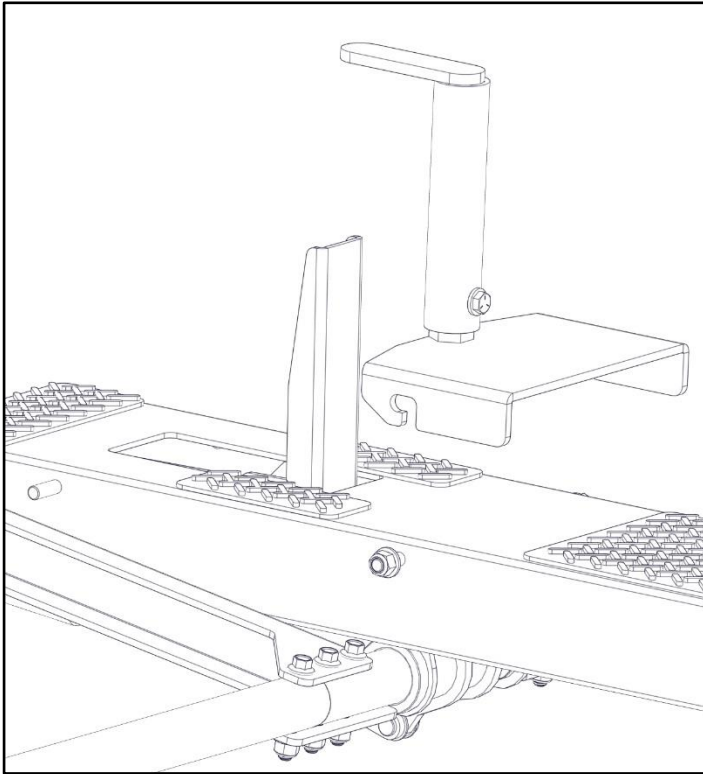

GO BACK AND ENSURE ALL HARDWARE IS TIGHTENED.

ASSEMBLY IS COMPLETE

KARGO MASTER®

WE PUT EVERYTHING WITHIN REACH.

Installation Guide

408SC

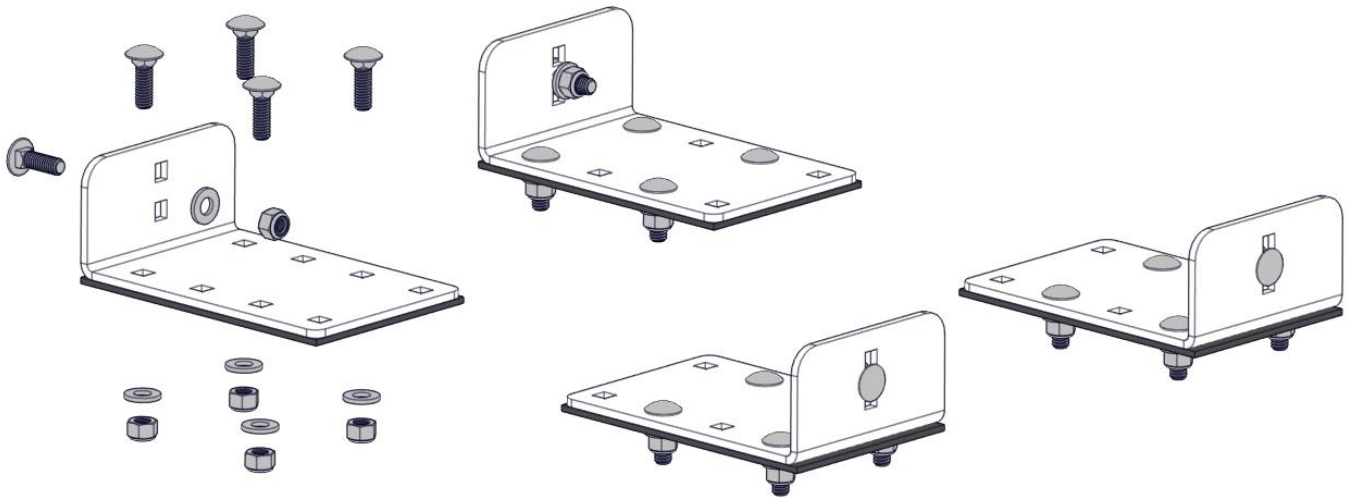

***PLEASE READ ALL INSTRUCTIONS AND WARNINGS PRIOR TO ASSEMBLING,
INSTALLING, AND USING THIS PRODUCT***

Warning



Always check for wires, fuel tanks and lines, brake lines and other important vehicle functionality items prior to drilling and installing all products.



Tools Needed

.340" Drill	1/2" Socket and Wrench

Before You Begin

- Read all instructions.
 - Have desired ladder rack ready to be installed.
 - Do NOT exceed manufacturers weight capacity.
-

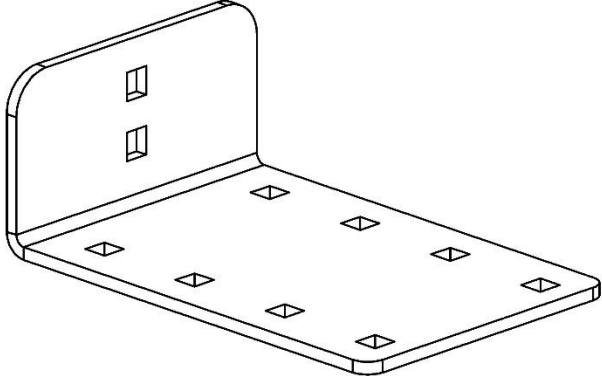
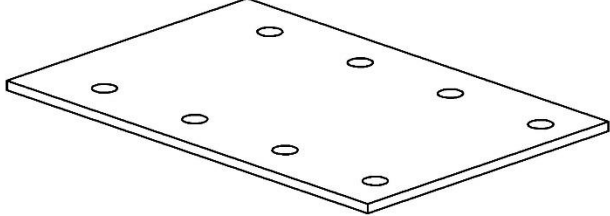
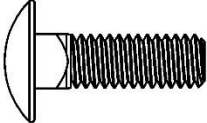
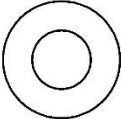
Parts/Hardware

ITEM NO.		PART NUMBER	DESCRIPTION	QTY.
1		4ADCU-00-001	MOUNT BRACKET, DCU, CAP	4
2		4ADCU-00-002	DCU-CAP-Rubber Pad	4
3		90185A583	5/16-18 x 1 Carriage Bolt	20
4		96659A107	5/16 Flat Washer	20
5		95615A160	5/16-18 Nyloc Nut	20
		BH-821	SEALANT	1

Step 1 – Foot Attachment

- Measure the approximate width of the flat section of the roof on the top of the shell.

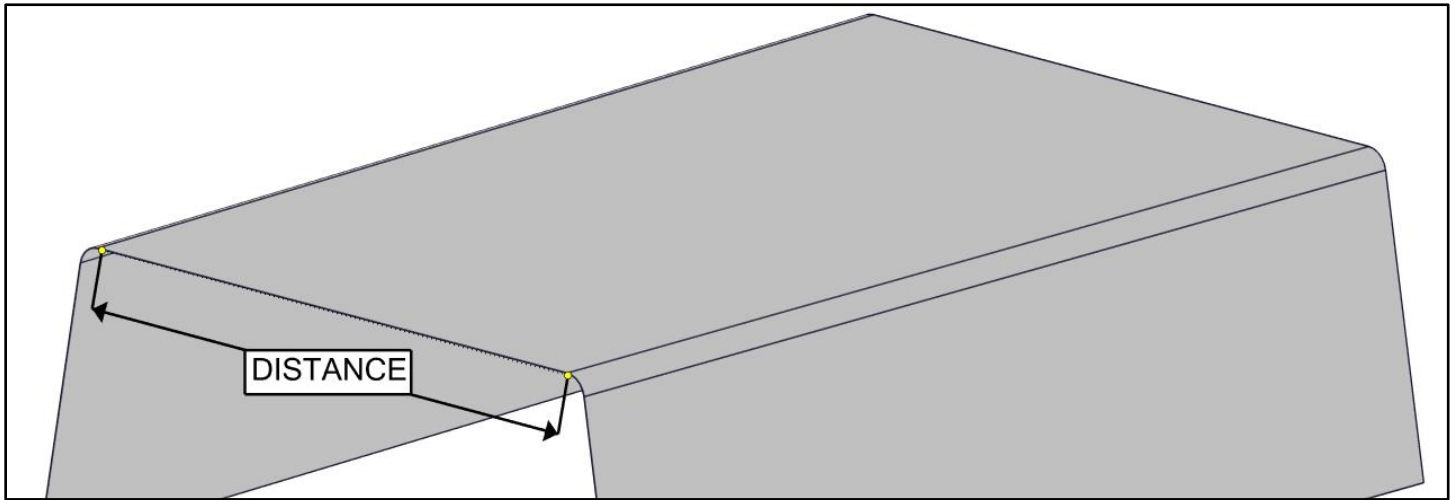

- Determine best mount locations on top of the shell and measure distance between the desired mounting locations.

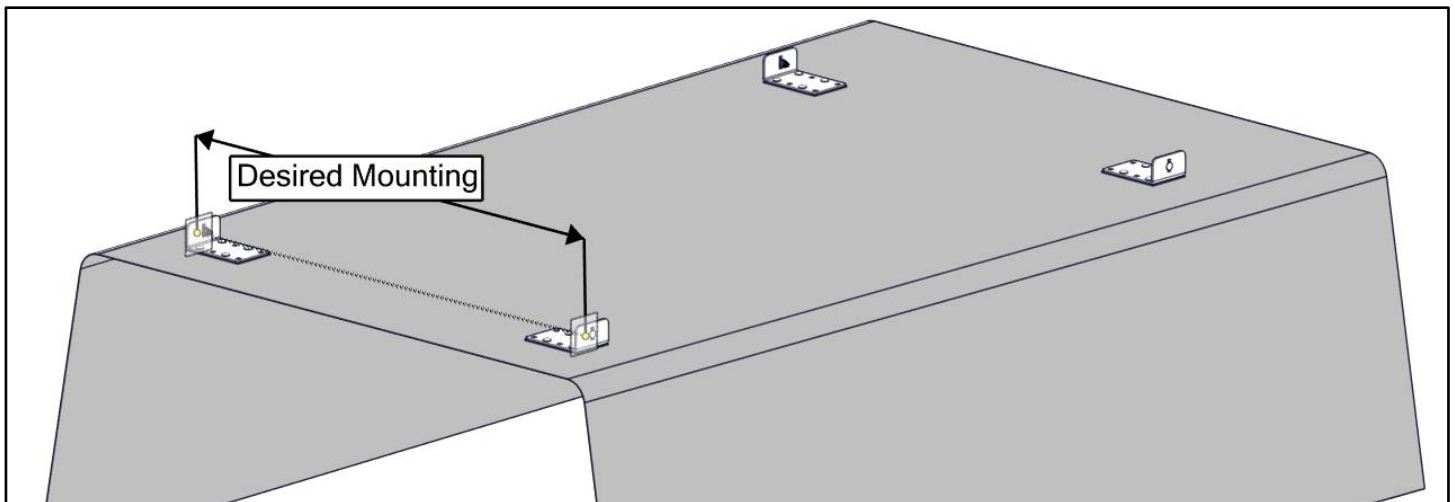

- At the width desired, find the corresponding slots on the ladder rack cross bow and attach mounting feet as shown.

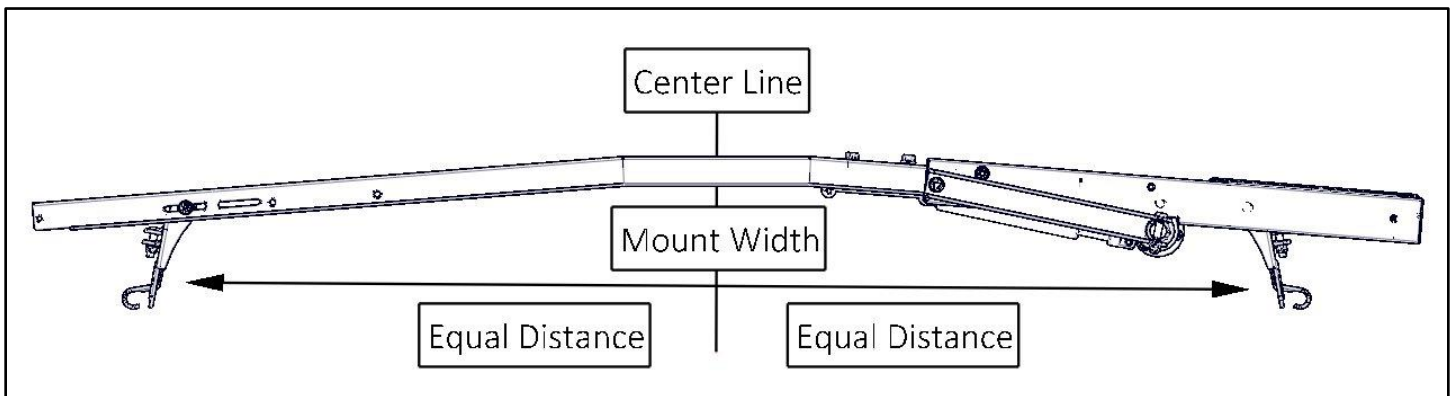

- Be sure there is an equal distance from the center of the cross bow to each foot.
- Leave feet loose until you set the assembly onto the vehicle.

Step 2 – Attach Mounts to Feet

- Attach feet on ladder rack to the mounting brackets from the 408SC kit using 5/16" x 1" carriage bolts, 5/16" flat washers and 5/16" nyloc nuts.
- Repeat at all four mount feet.
- Do NOT tighten. These will be removed in future steps.

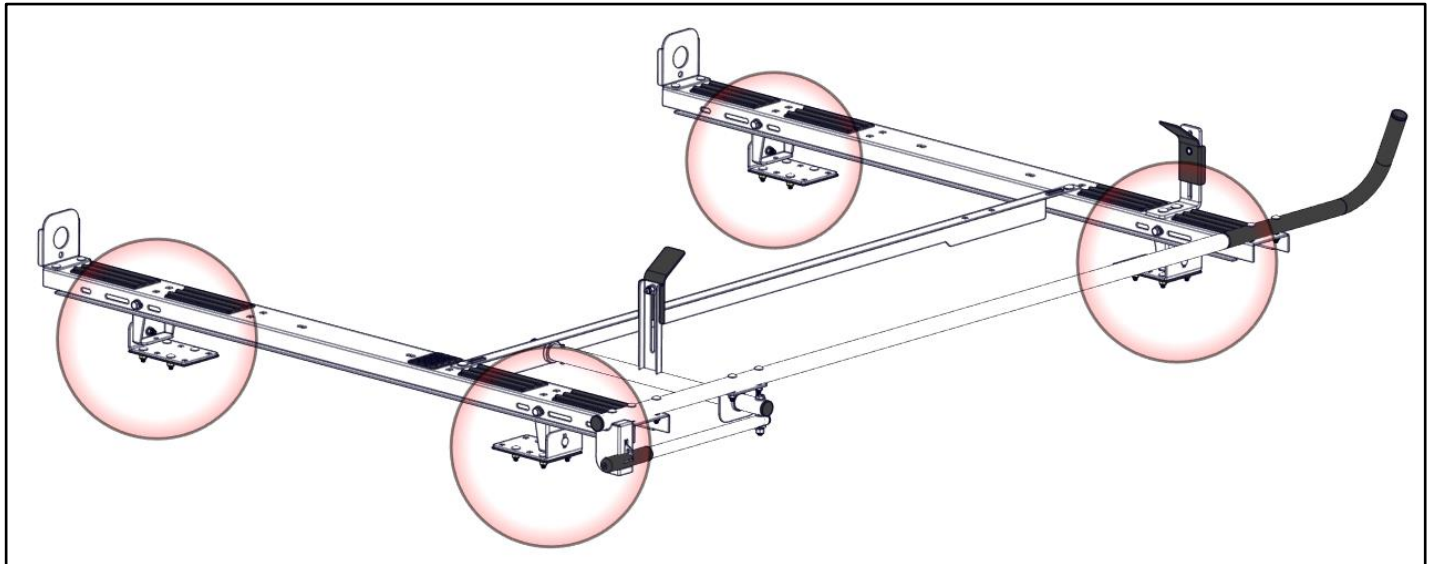
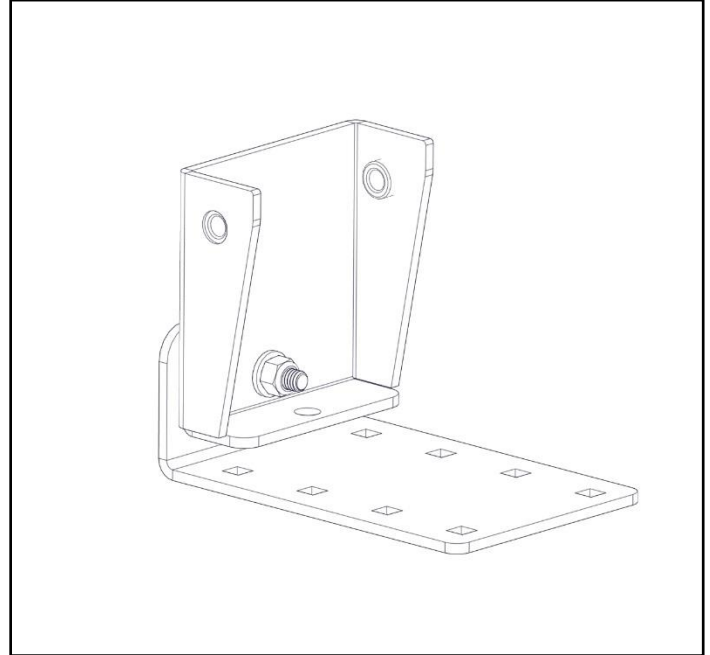
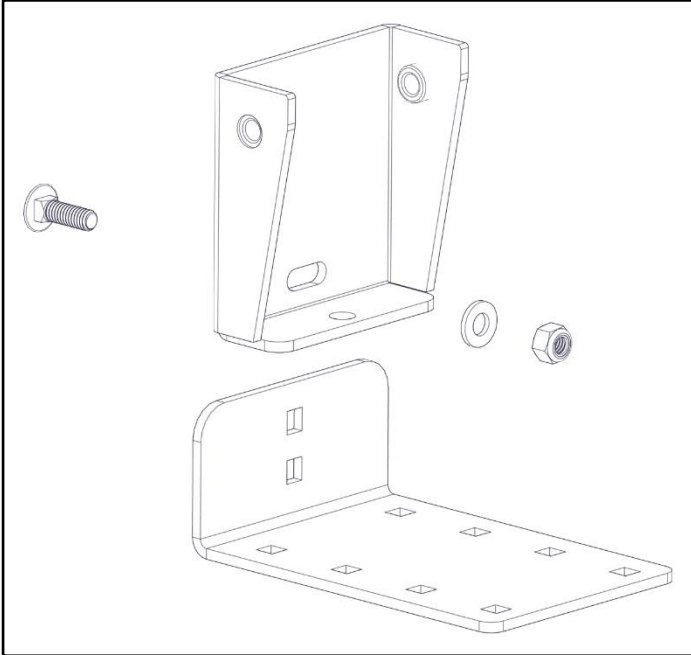

Step 3 – Place Rack on Shell

- Place rack on top of shell. Position rack to your liking. Be sure the rack is off-set far enough to the rear that one will not hit the shell when loading and unloading a ladder.
- Be sure the handle can be rotated without hitting the side of the shell.

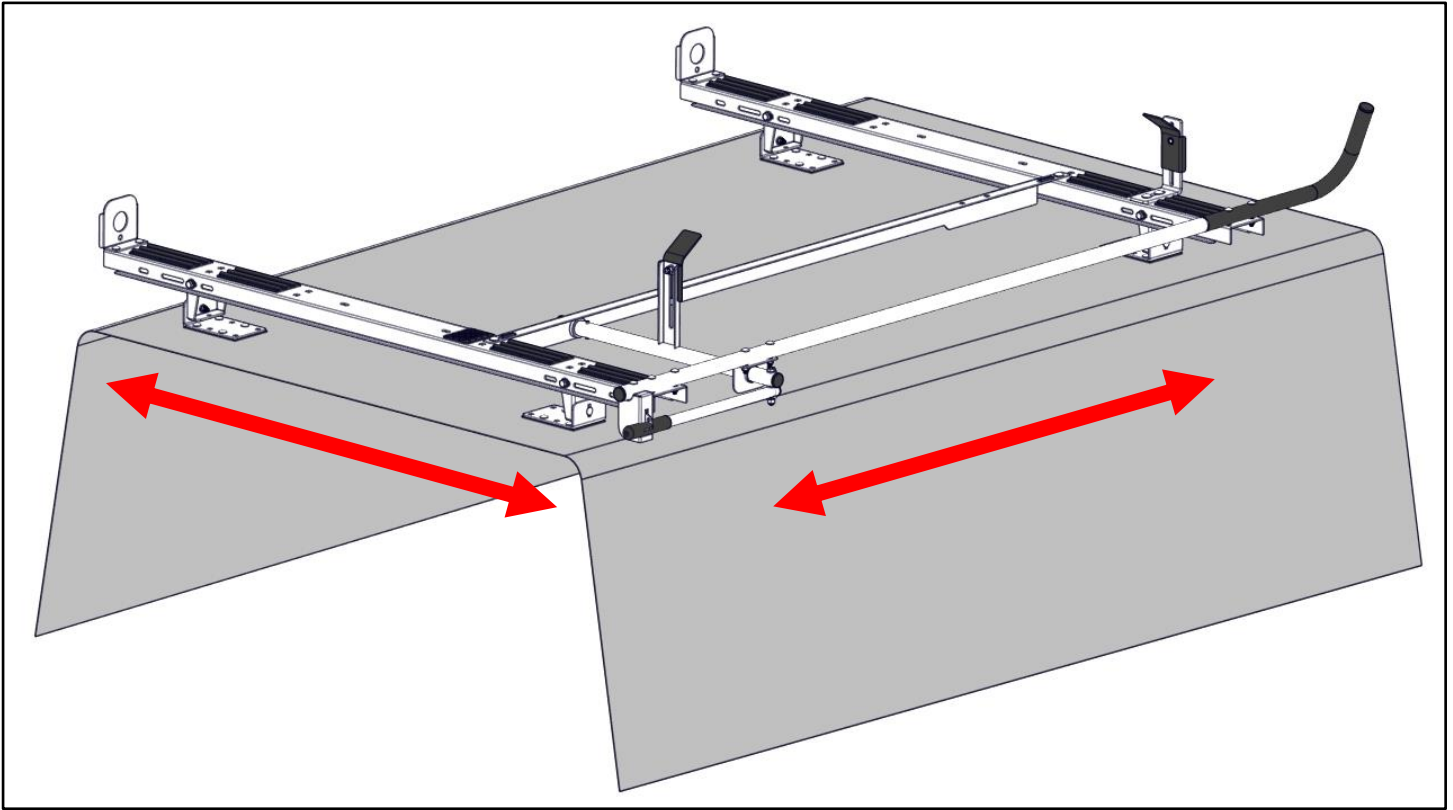

- Mark four locations at each foot mount location onto the top of the shell.

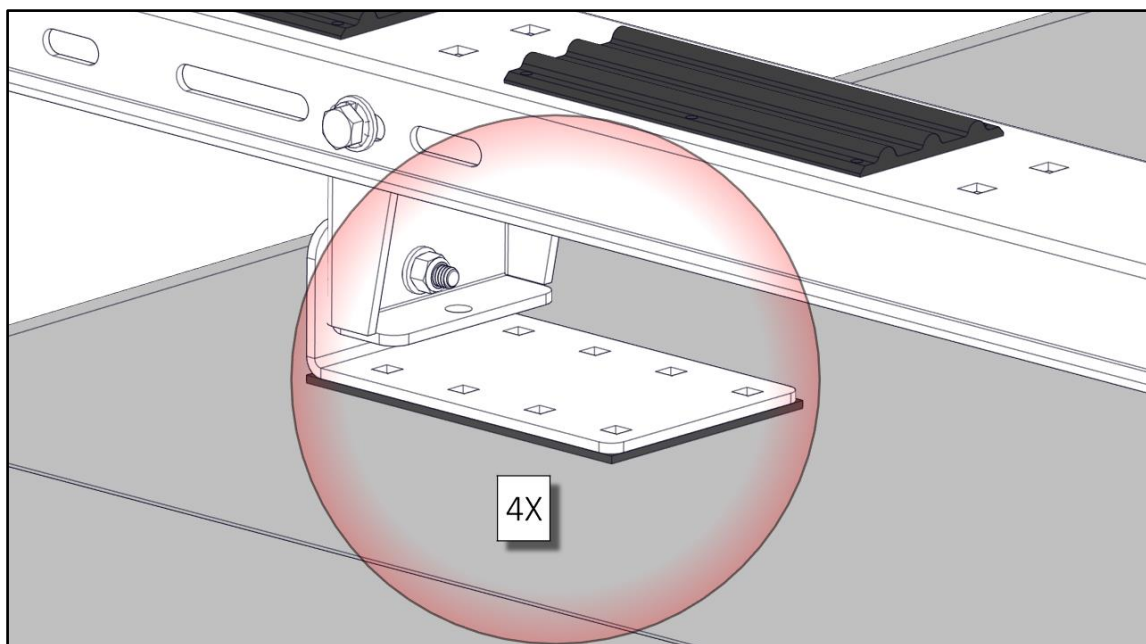

Step 4 – Remove Rack and Drill

- Remove rack with feet and mounts from the top of the shell.
- Drill in previously marked holes using a .340" bit.
- Ensure safety when drilling.

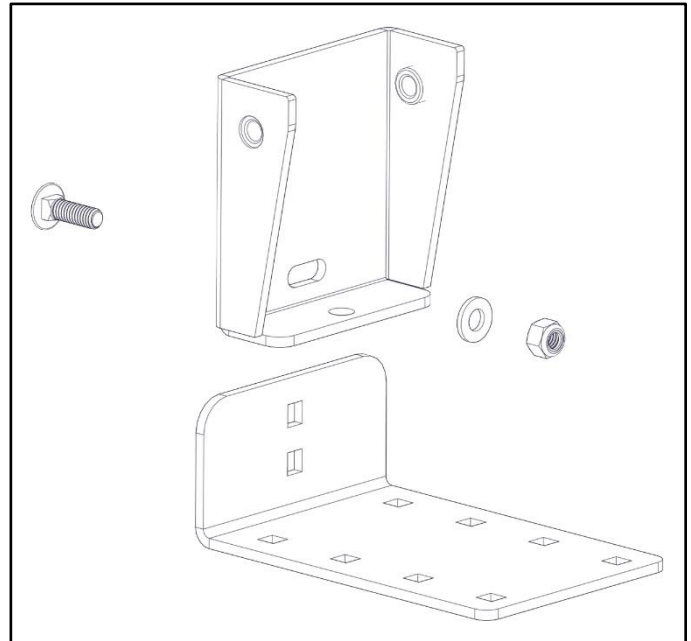

- Remove rack and feet from the feet mounts.

Step 5 – Mount Feet Mounts

- Mount feet mounts to the shell through the previously drilled holes using 5/16" x 1" carriage bolts, 5/16" flat washers and 5/16" nyloc nuts.
- Be sure rubber pad is between shell and mount bracket. Apply a generous amount of sealant around the holes drilled in the shell.
- Place sealant around hardware to ensure no water and leak into shell.
- Snug Tighten, but allow movement.

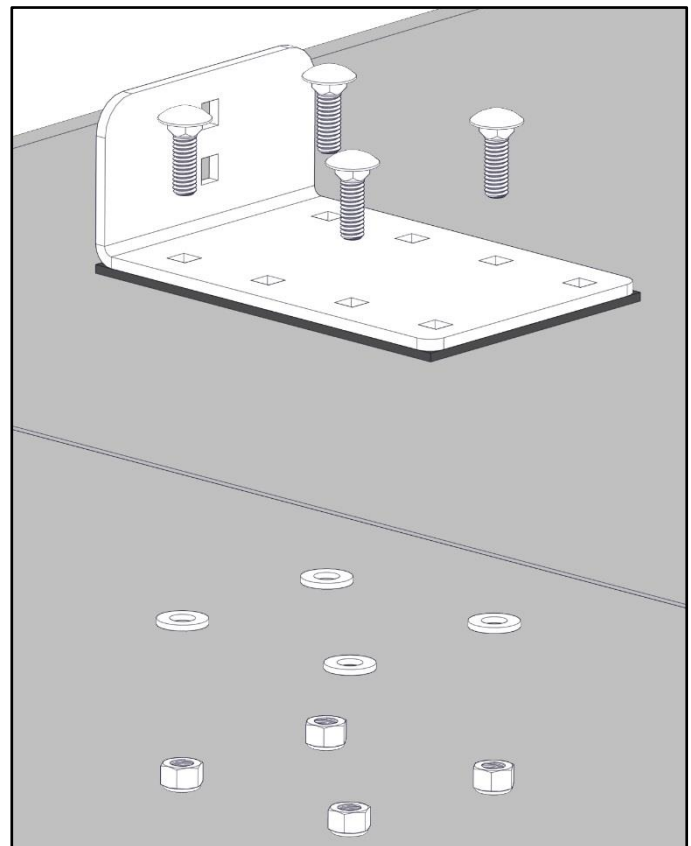
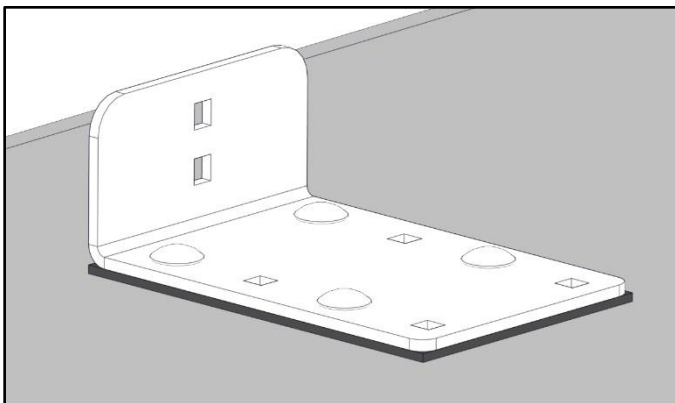

Step 6 – Mount Rack

- Place rack on top of previously installed feet mounts.
- Attach feet on ladder rack to the mounting brackets from the 408SC kit using 5/16" x 1" carriage bolts, 5/16" flat washers and 5/16" nyloc nuts.
- Repeat at all four mount feet.

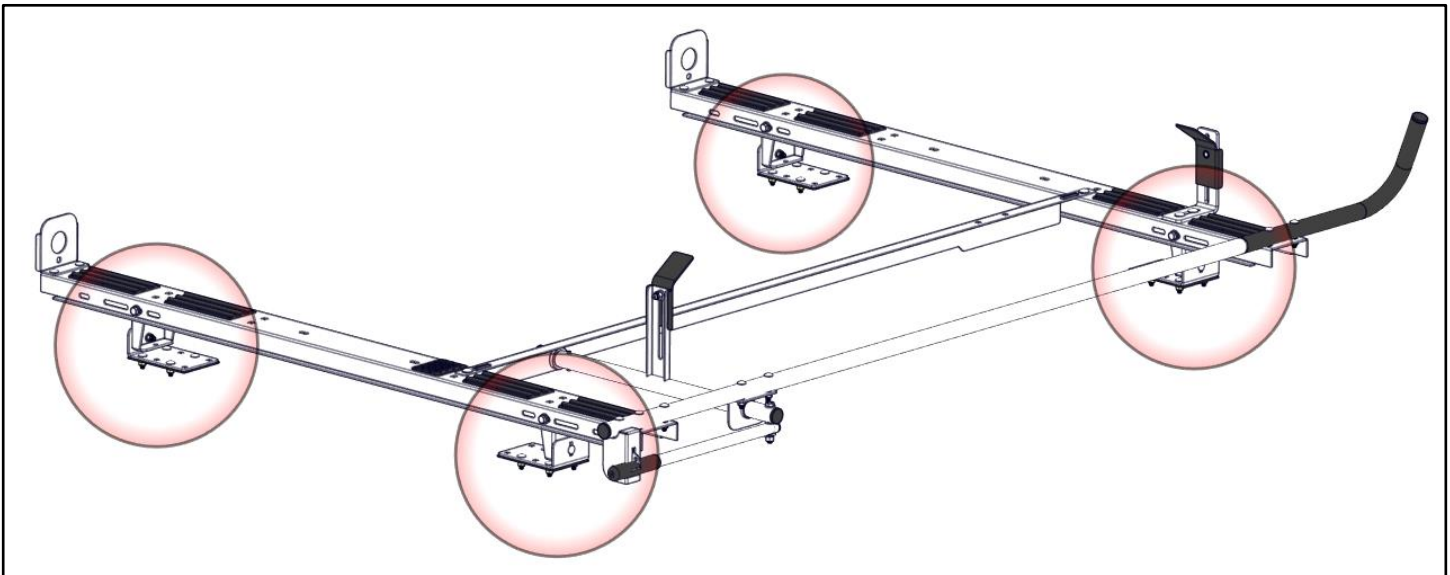
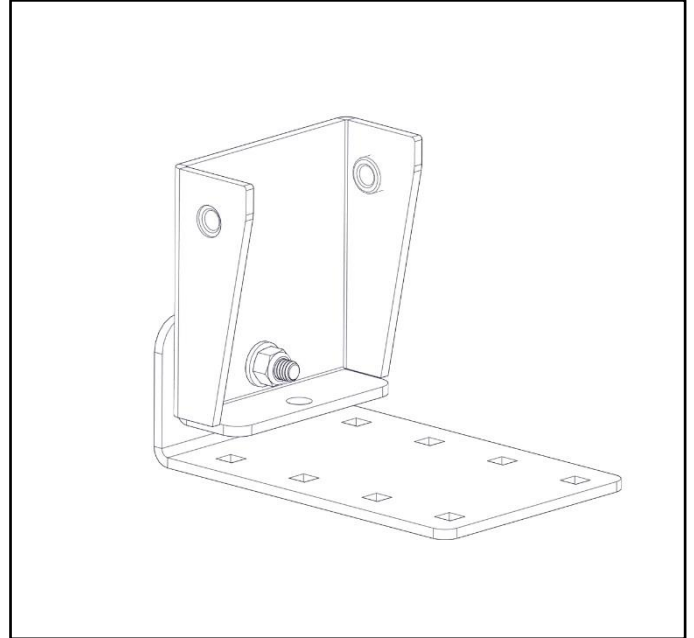
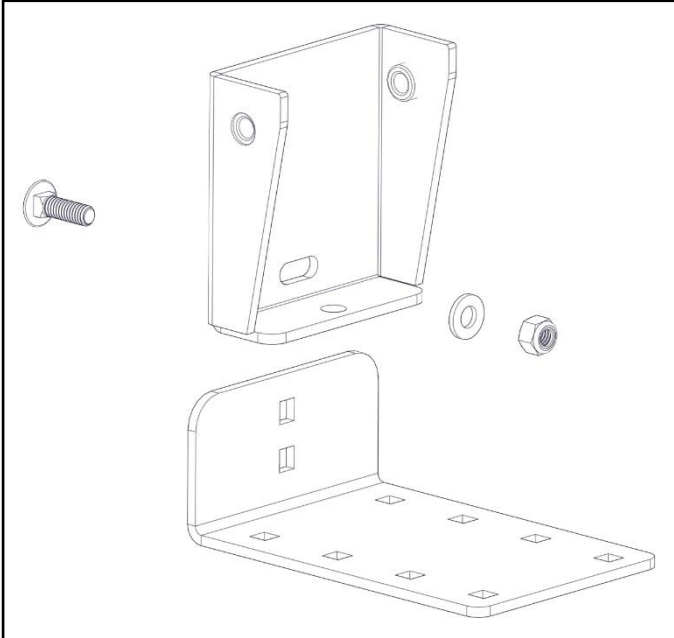

- Align and square rack on the shell.
- TIGHTEN.
- Go back and tighten hardware from step 5.

GO BACK AND ENSURE ALL HARDWARE IS TIGHT

Your installation is now complete.

