

# KARGO MASTER®

**WE PUT EVERYTHING WITHIN REACH.**

---

## Installation Guide

4A95M

---

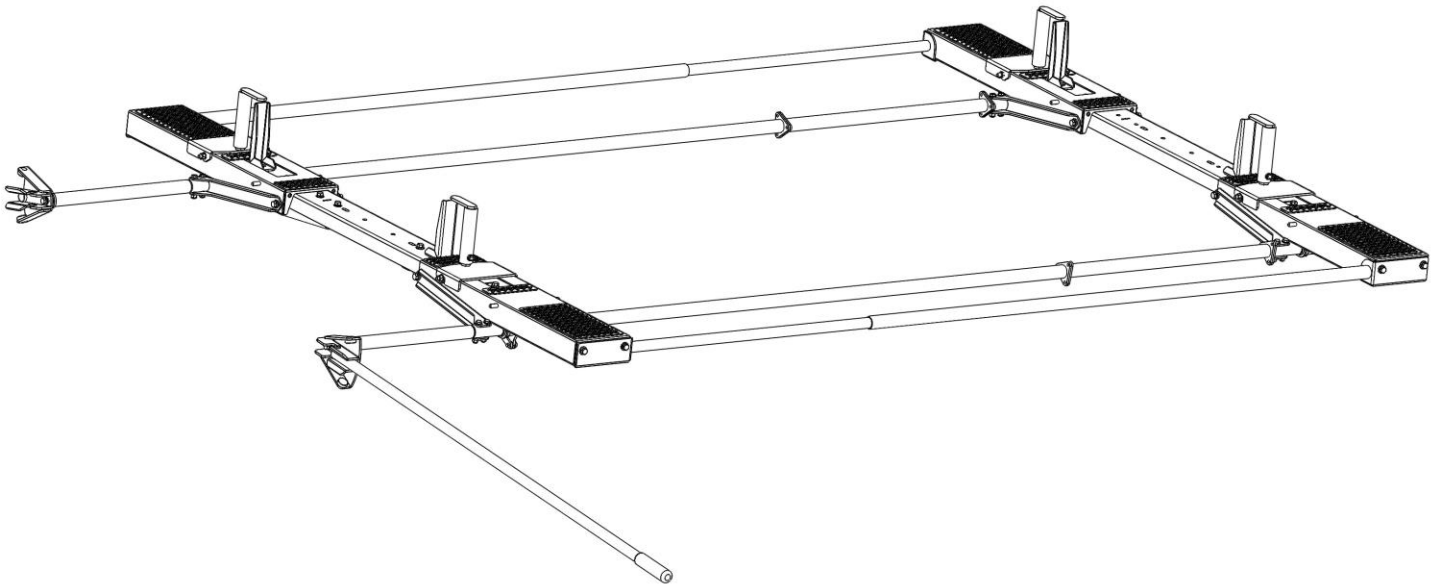

**\*PLEASE READ ALL INSTRUCTIONS AND WARNINGS PRIOR TO ASSEMBLING, INSTALLING, AND USING THIS PRODUCT\***

**Warning**



**Always check for wires, fuel tanks and lines, brake lines and other important vehicle functionality items prior to drilling and installing all products.**

**Tools Needed**

9/16" Wrench and Socket	7/16" Wrench and Socket
1/2" Wrench and Socket	3/8" Wrench and Socket
5/16" Wrench and Socket	Phillips Driver
1/4" Drill	

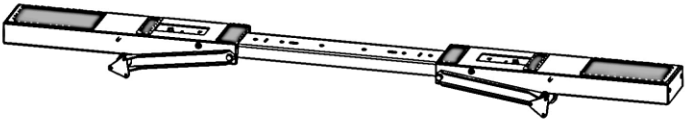
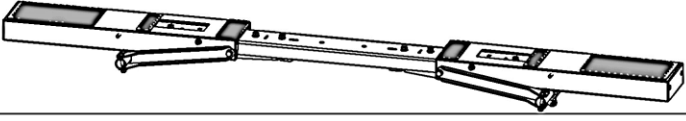
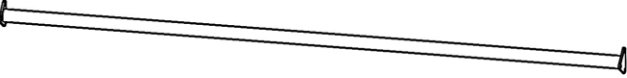
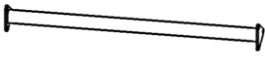
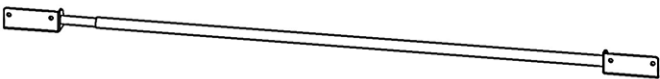
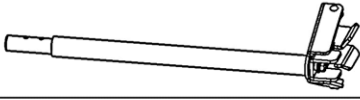
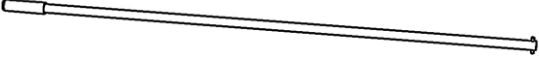
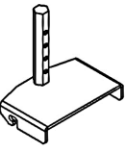
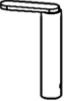

**Table of Contents**

Parts List.....	2
Hardware.....	3
Step 1 – Identify Front and Rear Bows.....	4
Step 2 – Determine if the Extension is Needed .....	4
Step 3 – Install Torque Tube Extension.....	5
Step 4 – Install Torque Tube .....	5
Step 5 – Install Ladder Pan Stiffeners .....	7
Step 6 – Determine Ladder Stop Locations.....	8
Step 7 – Install Handle.....	10
Step 8 – Assemble Ladder Hooks .....	10
Step 9 – Install Clips for Handle .....	11





**Before You Begin**

- Read all instructions before assembling or installing any Kargo Master product.
- Place sealant around all swage connections.
- Keep the adjustment guide in vehicle at all times.
- **DO NOT EXCEED MANUFACTURERS WEIGHT CAPACITY FOR ROOF.**
- **BE SURE TO ADJUST LADDER CLAMPS ACCORDINGLY TO FIRMLY SECURE LADDER TO RACK.**
- **Mounting kit is NOT included and must be purchased separately.**

**Parts List**

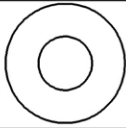
ITEM NO.	ITEM	PART NUMBER	DESCRIPTION	QTY.
1		4A95M-FRONT	FRONT BOW ASM	1
2		4A95M-REAR	REAR BOW ASM	1
3		4A93L-50	TORQUE TUBE, 71.5" LR	2
4		4A93L-51	TORQUE TUBE, EXTENSION LR	2
5		4A93L-7	SUPPORT TUBE ASSY	2
6		100531	ACTUATOR	2
7		40800-13	OPERATOR ARM ASSEMBLY	1
8		4A900-36	BASE LADDER HOOK WELDMENT	4
9		4A900-35	LADDER HOOK	4
10		4A900-30-004	LADDER STOP	4
11		18-4A95M	HARDWARE KIT	1

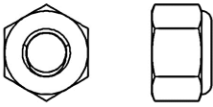
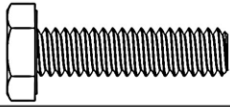
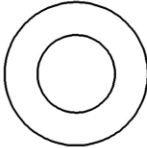
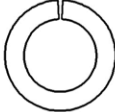
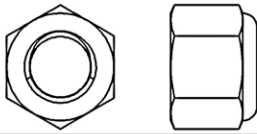
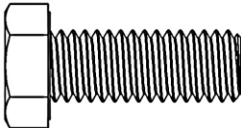
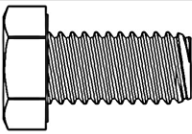
**Hardware**

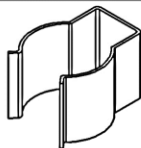
ITEM	HARDWARE TO SCALE	PART NUMBER	DESCRIPTION	QTY.
1		11541082	1/4 FLAT WASHER	40
2		33618	1/4" LOCK WASHER	4
3		0169789	1/4-20 NYLOC NUT	18
4		110120304	1/4-20 X 1" HEX HEAD	22
5		11541089	3/8" STEEL FLAT WASHER	12
6		0123496	3/8 LOCK WASHER	8
7		0169791	3/8-16 NYLOC NUT	2
8		11241197	3/8-16 X 1" HEX HEAD BOLT	2
9		11241196	3/8-16 X 3/4" HEX HEAD BOLT	8
10		74803	#10-24 X 5/8" PHILLIPS HEAD SCREW	2
11		37515	10-24 NYLON INSERT LOCK NUT	2
12			HANDLE HOLDER	2
13			SEALANT	1

**Step 1 – Identify Front and Rear Bows**

- Determine front and rear bow. The rear bow will have a dampening mechanism attached. Notice the location of the triangular piece.

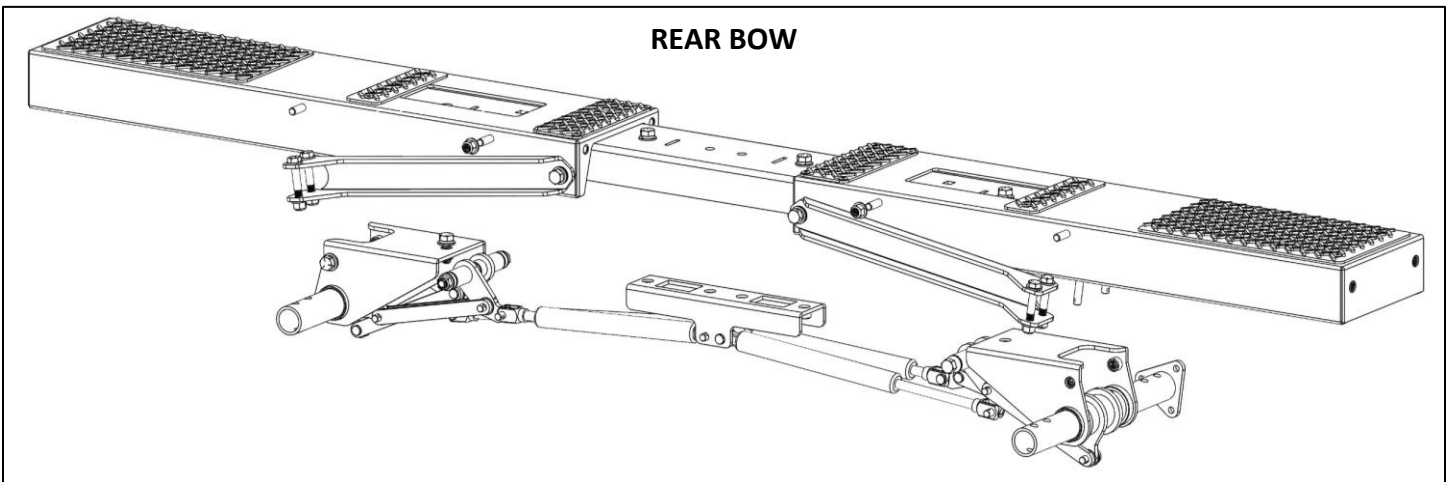
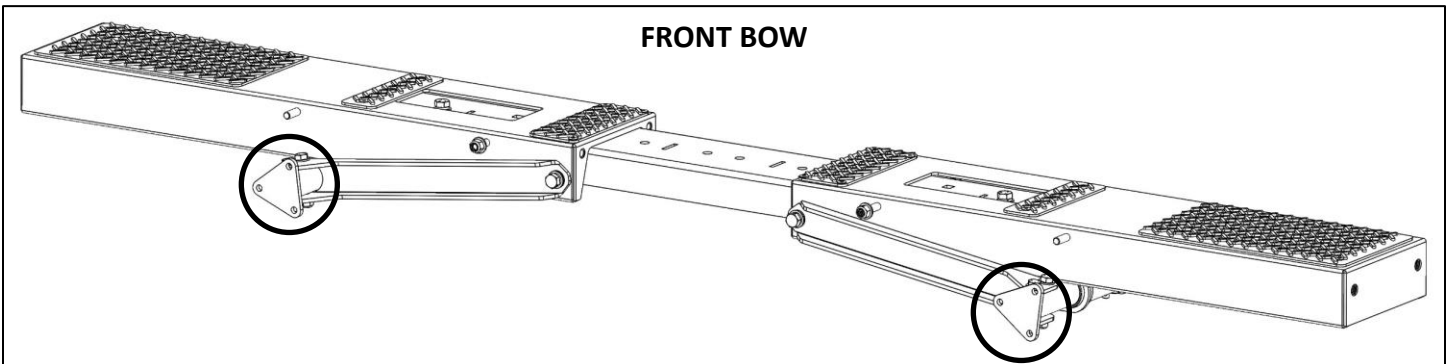

**Step 2 – Determine if the Extension is Needed**

- Based upon the vehicle and ladder needs, the rack length can be extended 24-1/2" by adding the included torque tube extension.
- The distance center of bow to center of bow **without** the extension is approximately **71.5"**.
- The distance center of bow to center of bow **with** the extension is approximately **96"**.

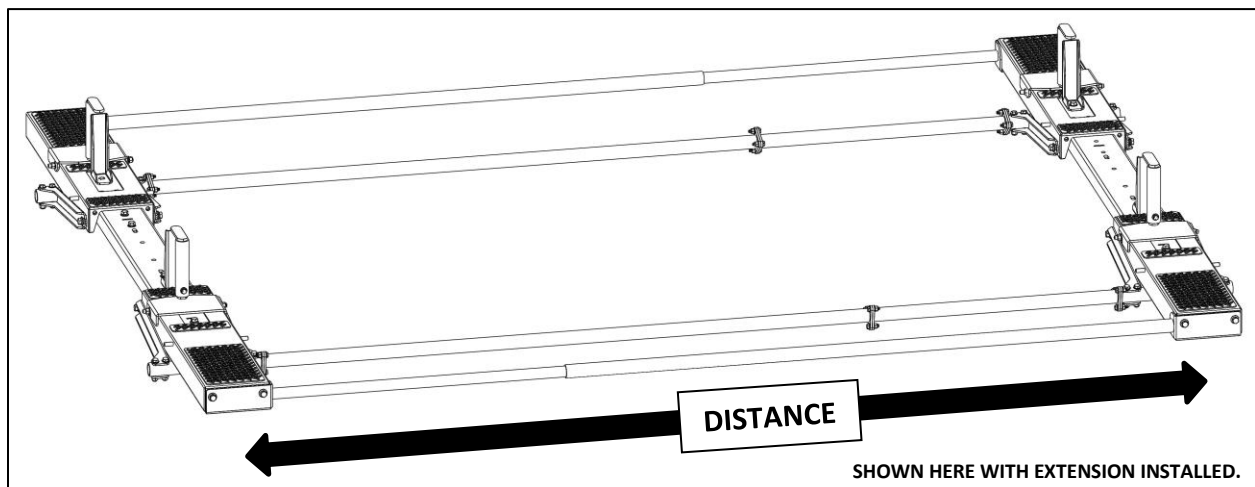

### **Step 3 – Install Torque Tube Extension**

If installation requires the torque tube extension, complete the following instruction. If NOT installing the torque tube extension, skip to the next step.

- Bolt the torque tube to the torque tube extension using a 1/4"-20 x 1" hex head bolt, two 1/4" flat washers, and a 1/4"-20 lock nut at each location.
- Repeat for second extension on opposite bow.

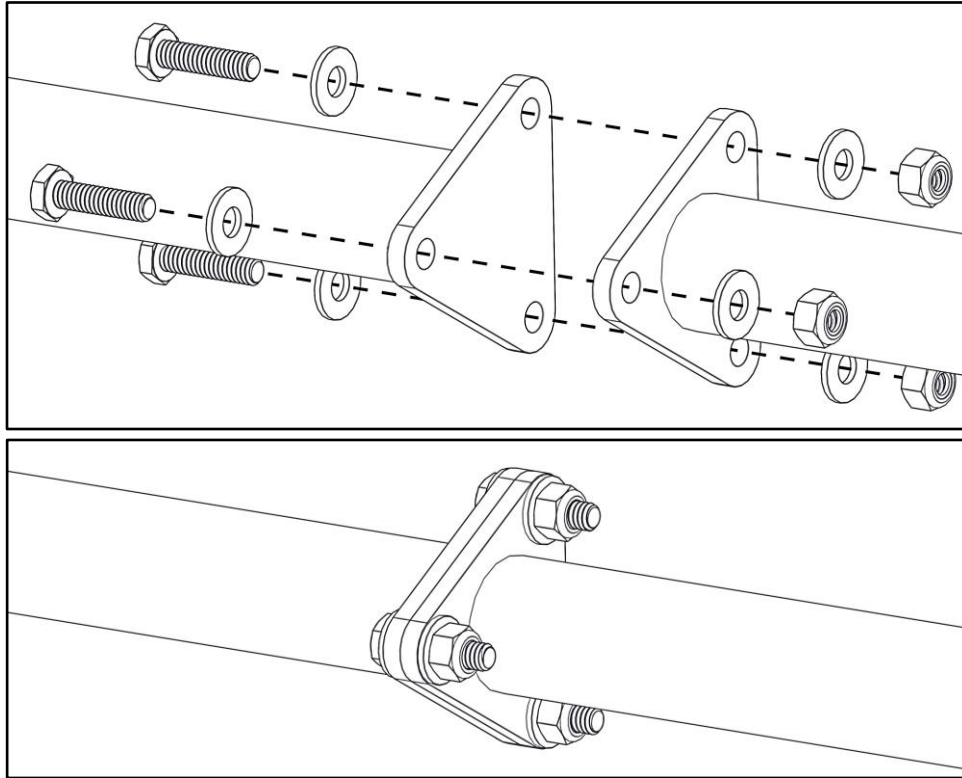

### **Step 4 – Install Torque Tube**

- Bolt the torque tube to the front and the rear bow using a 1/4" x 1" hex head bolt, two 1/4" flat washers and a 1/4" lock nut at each of the 3 holes through triangular ends of torque tube and actuator on bow.
- Repeat for second torque tube and extension on opposite side of rack.
- Snug tighten but allow for movement. This hardware is best tighten after installation.

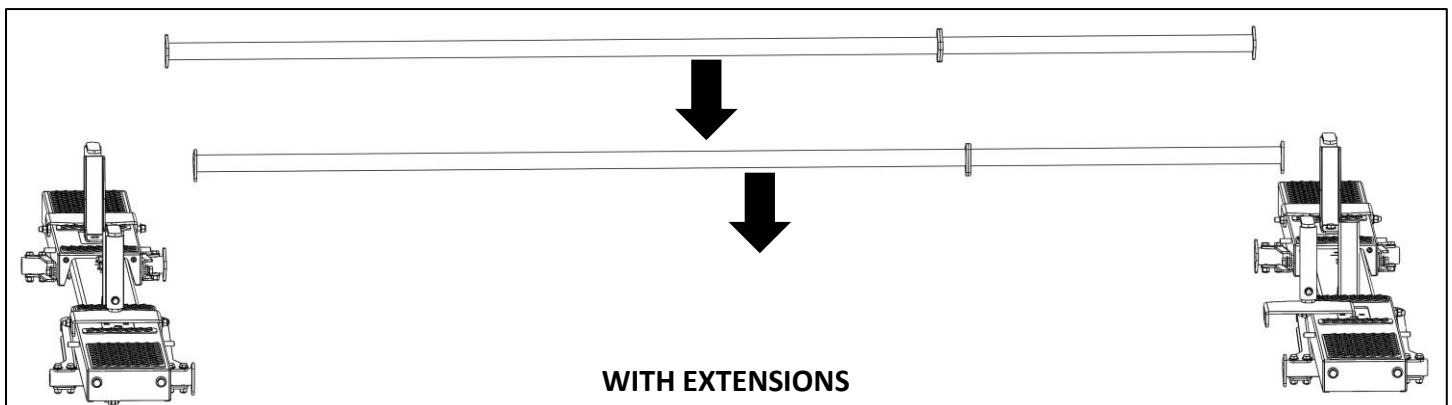

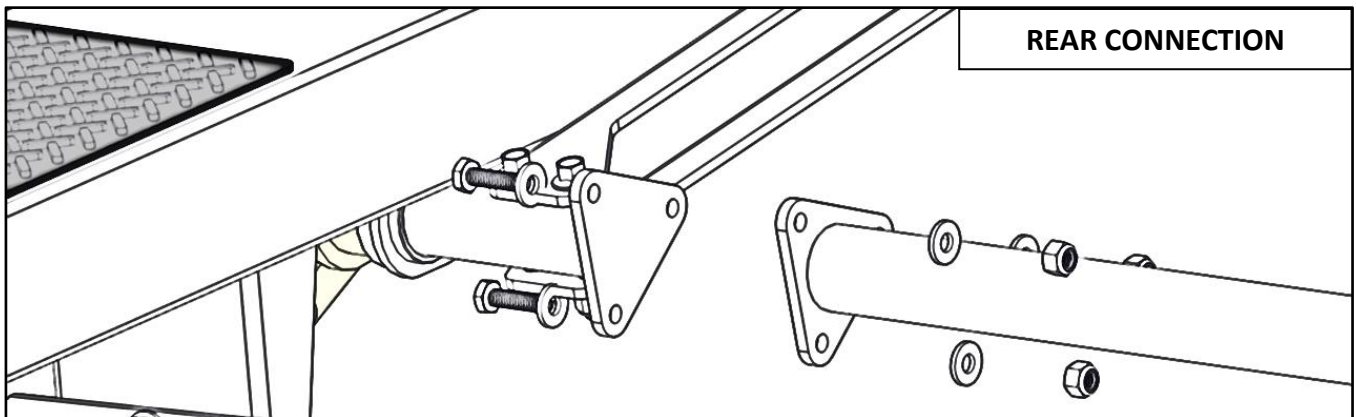
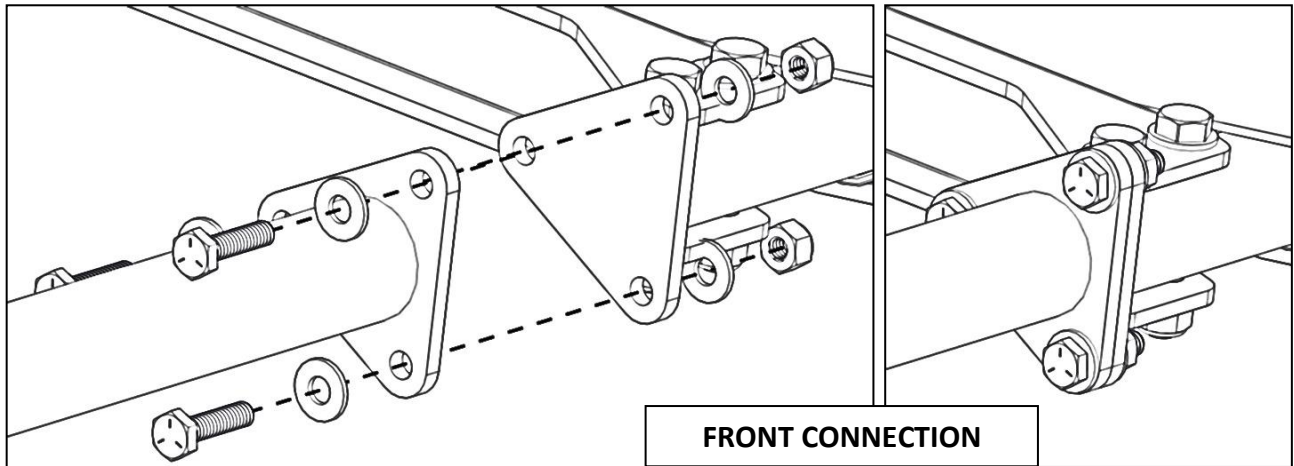
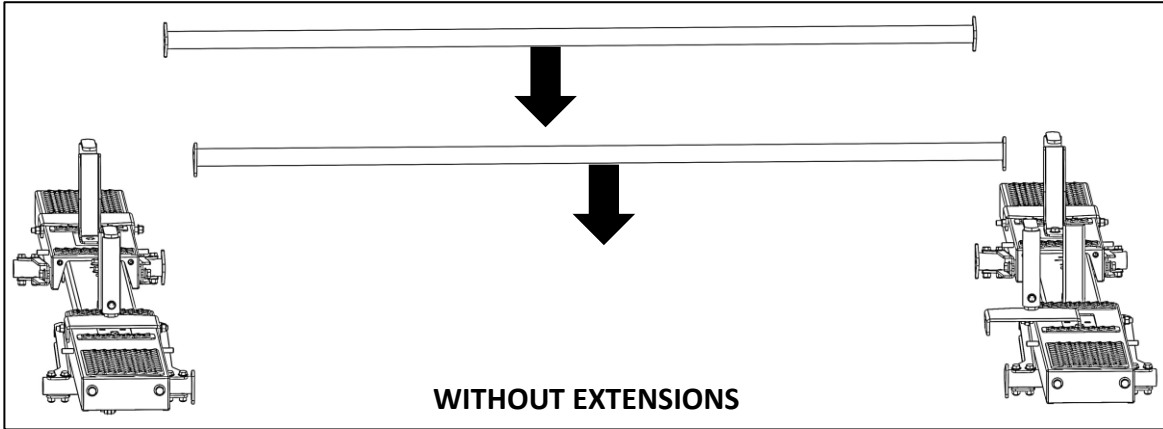

**Step 5 – Install Ladder Pan Stiffeners**

- Using 3/8" x 3/4" hex heads, 3/8" lock washers and 3/8" flat washers, install ladder pan stiffener to the ends of the bow pan assembly on each bow.
- TIGHTEN.
- Repeat on opposite side of rack.

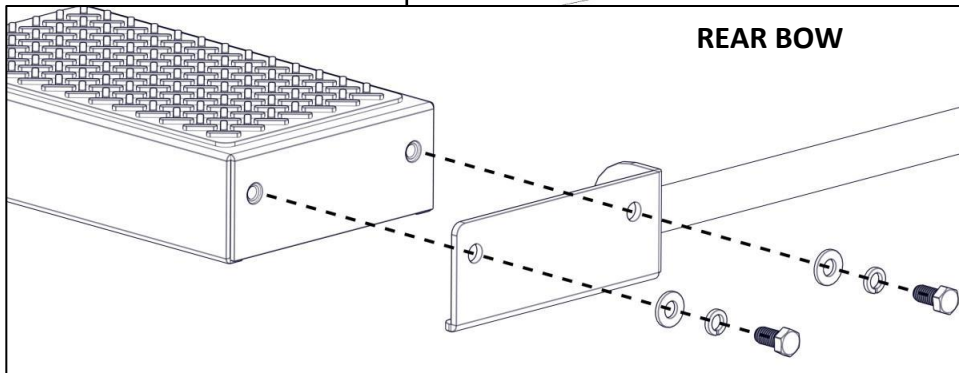
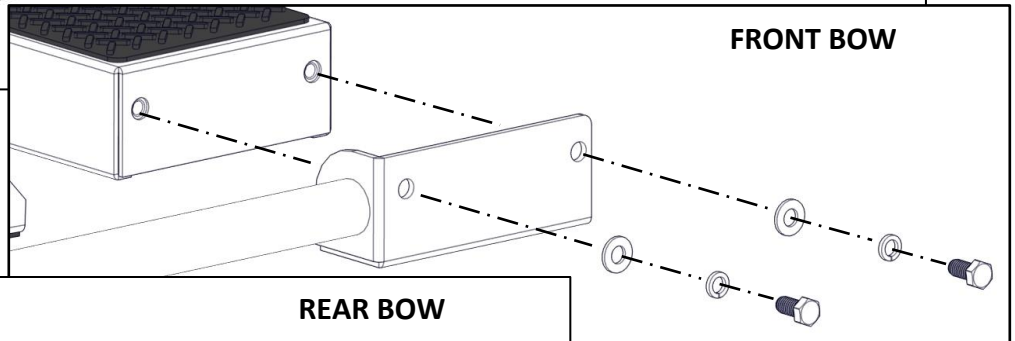
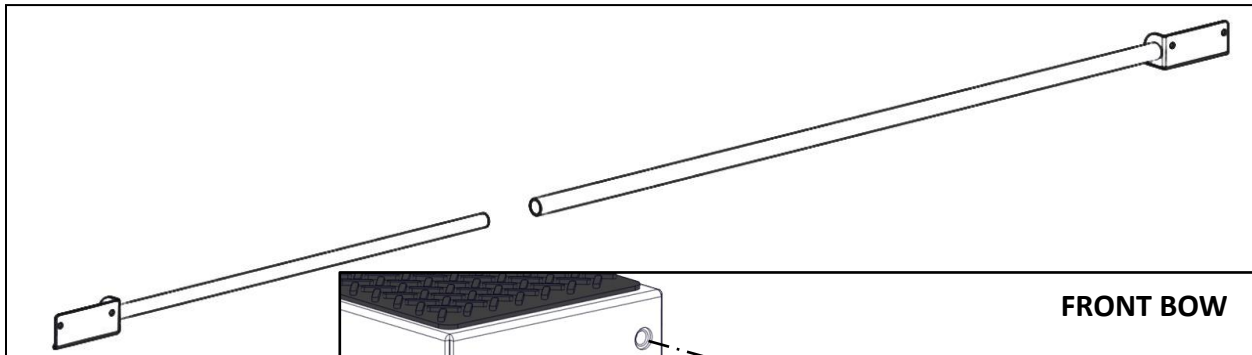
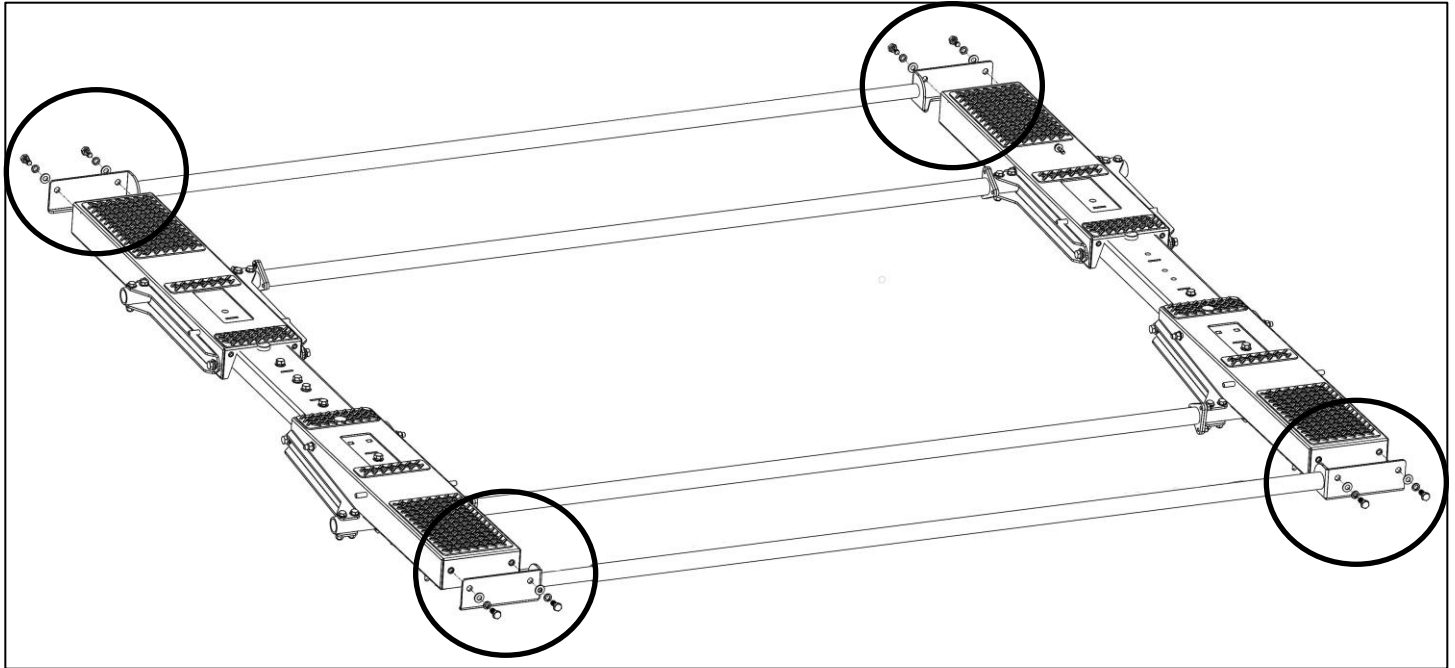



## Step 6 – Determine Ladder Stop Locations

**NOTE:** On side of each bow, there are two positions available for mounting the ladder stops and ladder hooks based on the size and type of ladder. Ladder stops may be installed either further inboard or further outboard, depending on the ladder to be used. It is best to determine the size and type of ladder prior to installing the ladder stops and ladder hooks. The following are examples of a typical 8 foot stepladder and 10 foot extension ladder mounted on the drop down ladder rack.

The following are the two positions available on each bow.

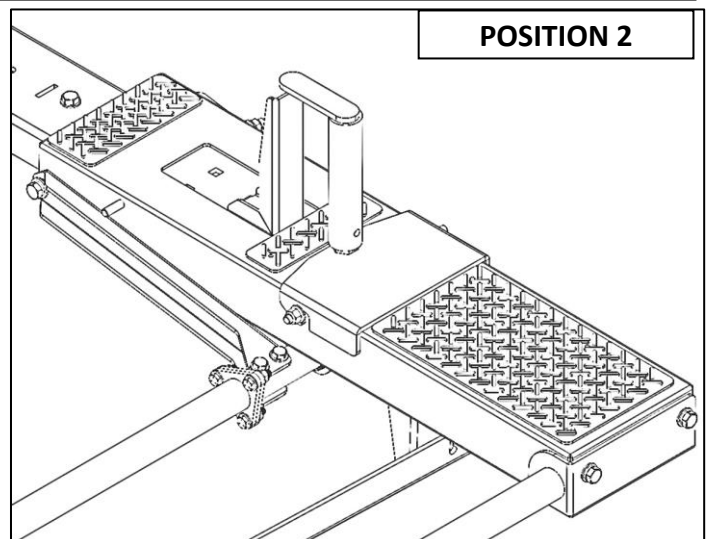
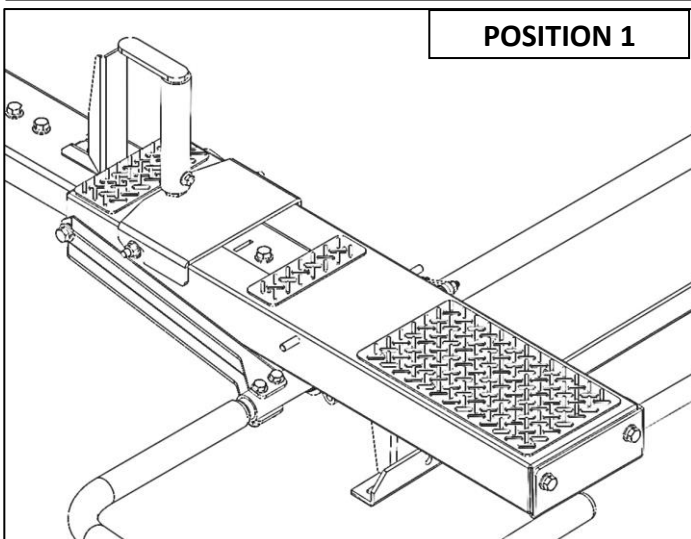
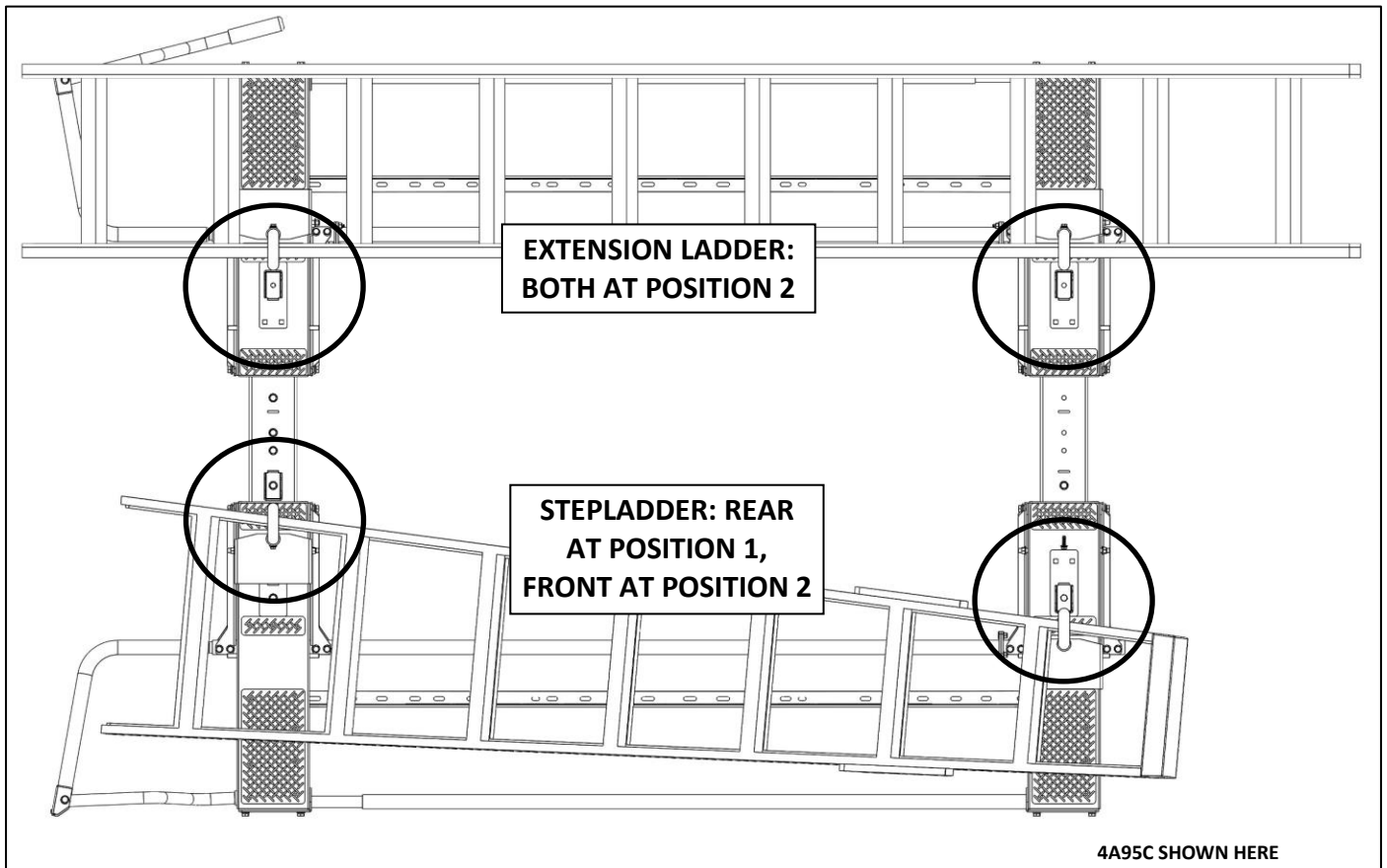

**Position 1**

- For each ladder hook in this position, place the ladder hook base around the threaded studs in the desired location and tighten.
- For the rear bow, remove the existing 3/8" x 1" hex head bolt, a 3/8" lock washer and a 3/8" flat washer. For the front bow, use a 3/8" x 1" hex head bolt, 3/8" flat washer, and 3/8" lock nut from the hardware kit.
- Position the ladder stop near the ladder hook base, as shown, with the flange on ladder stop aligned with the slot in the bow.
- Install ladder stop and tighten.

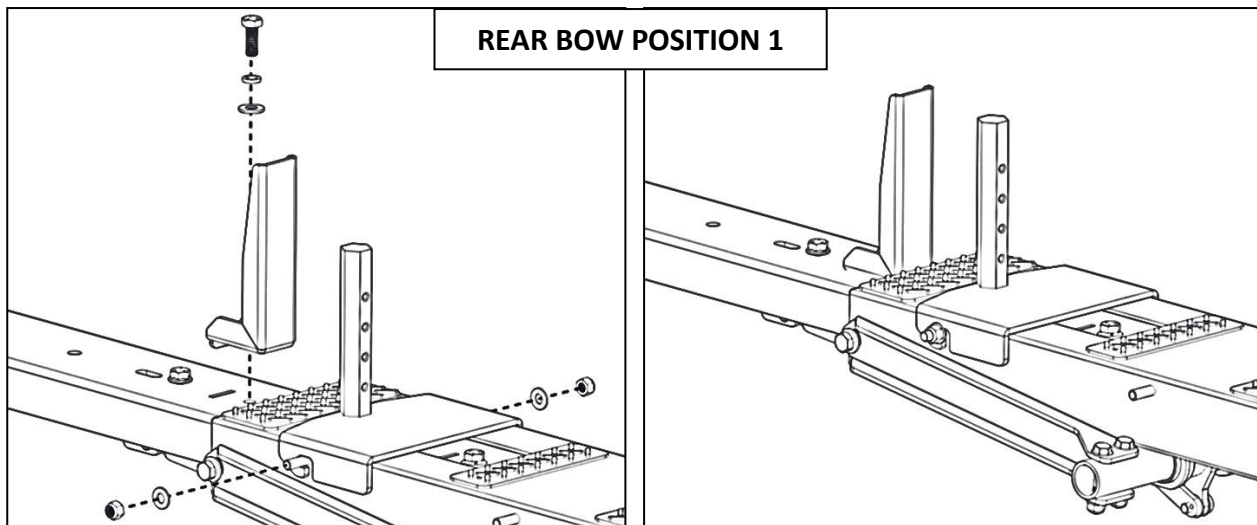
**Position 2**

- For each ladder hook in this position, place the ladder hook base around the threaded studs in the desired location and tighten.
- Position the ladder stop near the ladder hook base, as shown, with the flange on ladder stop aligned with the slot in the bow.
- Remove the existing 3/8" x 1" hex head bolt, a 3/8" lock washer and a 3/8" flat washer.
- Bolt the ladder stop in place using the removed hardware in the orientation shown.

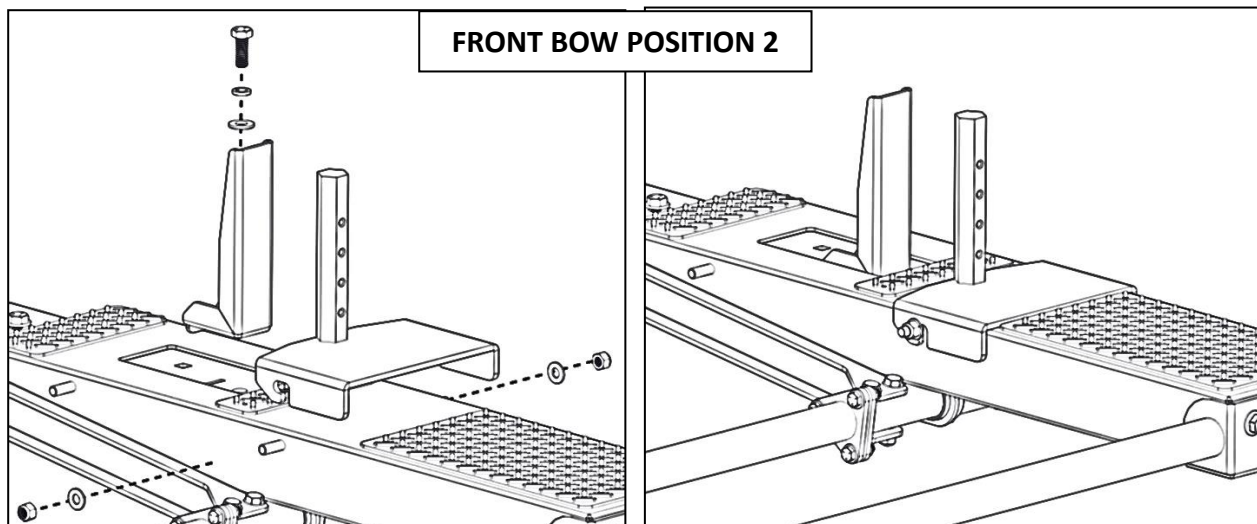

### Step 7 – Install Handle

- Remove the 5/16" flanged head screws, 5/16" washers, and 5/16" lock nuts from rear bow as circled below.
- Apply sealant to swaged ends of handles.
- Use removed hardware to bolt handles into position as shown.
- TIGHTEN.

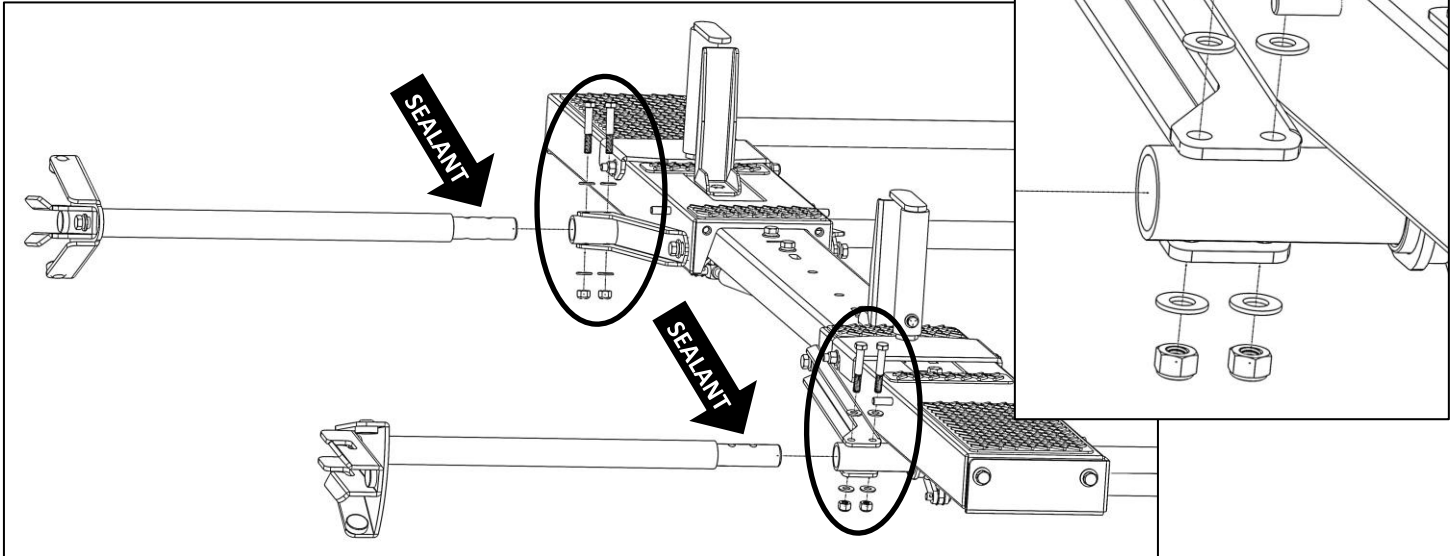

### Step 8 – Assemble Ladder Hooks

- Install the ladder hooks on the previously installed ladder hook base using 1/4" x 1" hex head bolts, 1/4" lock washers, and 1/4" flat washers in the desired locations. The location is dependent on the size of the ladder used. Adjust so the ladder hook fits the ladder as tight as possible.
- TIGHTEN.
- Repeat for remaining 3 ladder hook locations.

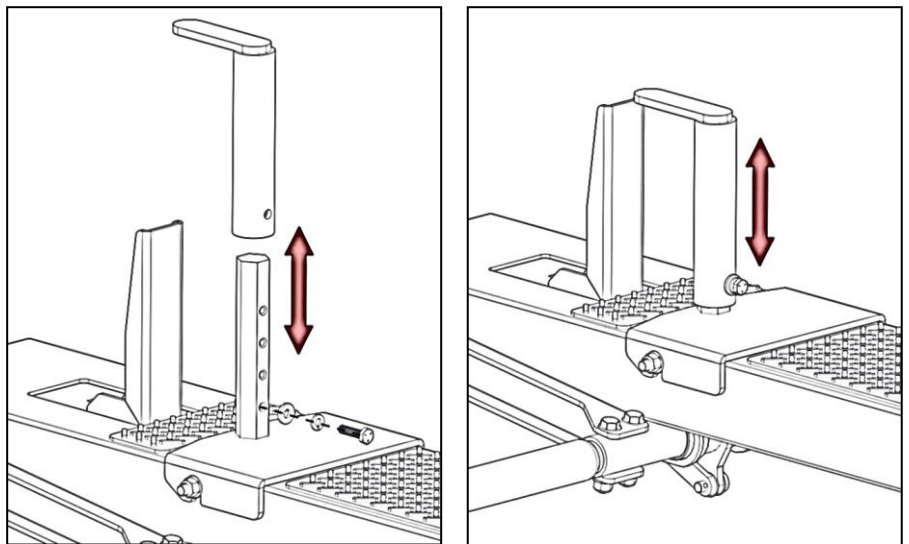

### **Step 9 – Install Clips for Handle**

- Locate a good mounting place to install the clips for the handle. It is recommended to place at the rear of the van on the rear panel of a shelf.
- Place the clips on the handle. Place the handle against the shelf in the desired location.
- Mark the holes onto the shelf.
- Drill the locations using a 1/4" drill.
- Attach clip using a #10 x 5/8" pan head screw and #10 lock nut.
- Repeat for second clip.
- TIGHTEN.

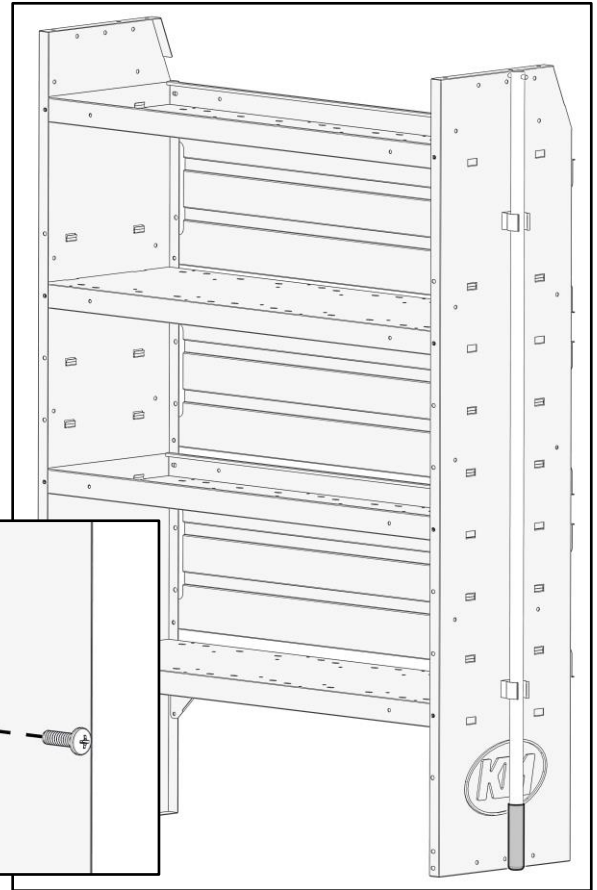

**REFER TO MOUNTING KIT INSTRUCTIONS FOR INSTALLATION.**

**ASSEMBLY IS NOW COMPLETE.**