

KARGO MASTER®

WE PUT EVERYTHING WITHIN REACH.

Installation Instructions

4A90L

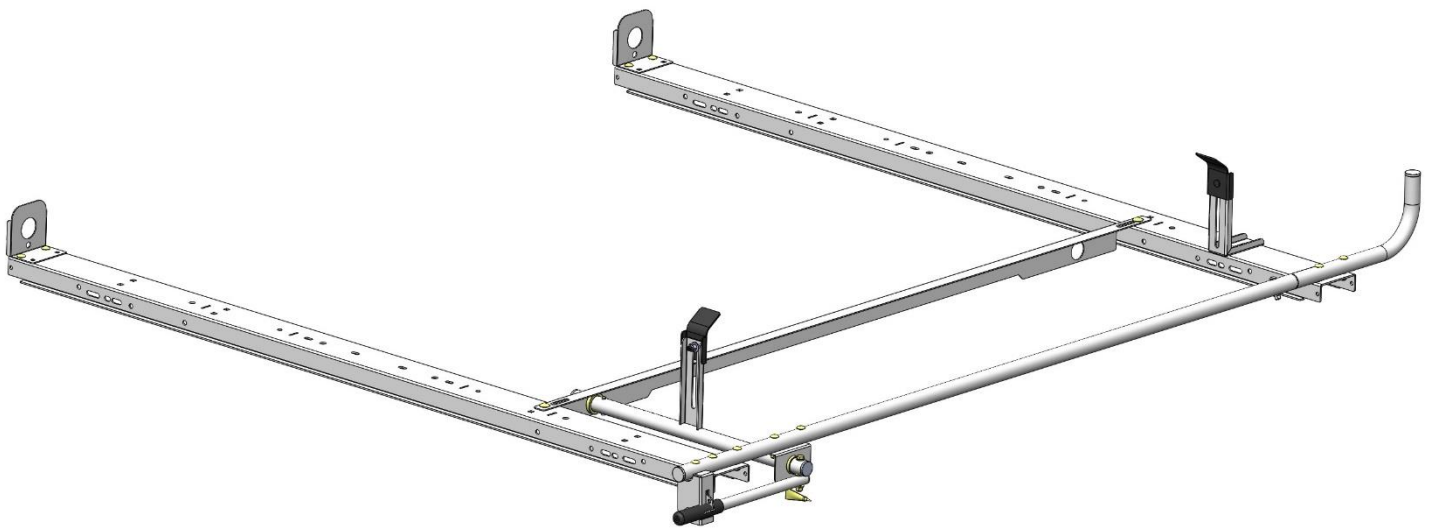

***PLEASE READ ALL INSTRUCTIONS AND WARNINGS PRIOR TO ASSEMBLING,
INSTALLING, AND USING THIS PRODUCT***

Warning



Always check for wires, fuel tanks and lines, brake lines and other important vehicle functionality items prior to drilling and installing all products.







Tools Needed

9/16" Socket and Wrench	1/2" Socket and Wrench
-------------------------	------------------------

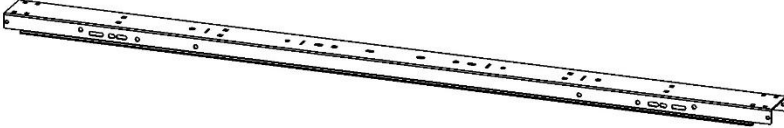

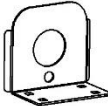
Before You Begin

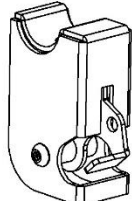
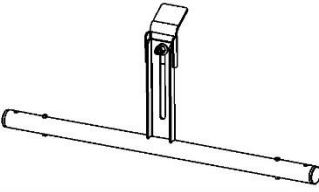
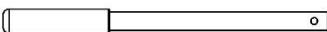
- Read all instructions. Find your vehicle roof rail mounting prior to rack assembly.
- Be sure to put E6000 sealant around all threads entering cargo area and between the rubber spacer and roof of vehicle to prevent water from leaking into cargo area.
- **DO NOT EXCEED MANUFACTURERS WEIGHT CAPACITY FOR ROOF**
- **PLACE ANTI-SEEZE ON ALL THREADS**
- **BE SURE TO SAVE E6000 AND ANTI-SEEZE FOR MOUNTING KIT**

Parts

ITEM NO.		PART NUMBER	DESCRIPTION	QTY.
A		4A900-00-001	40933/40873 BOW	2
B		4A800-00-003	Clamp and Lock L Bracket	1
C		4A800-00-004	ladder stop	2
D		4A800-00-005	rotation bar plate	1
E		4A800-20	Latch Assy.	1
F		4A800-30	Clamp Tube	1
G		4A800-40	Handle	1
H		4A800-50	Side Tube Assembly	1
J		4A800-60	Ladder Stop Assembly	1
		18-4A800	Aluminum Clamp n Lock Assembly Hardware	1

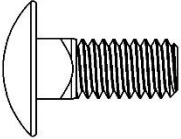
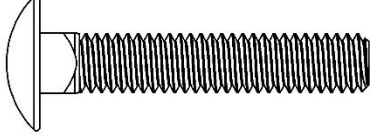
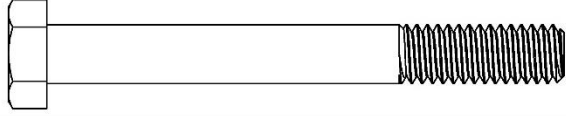
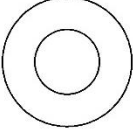
Assembly Hardware (18-4A800)

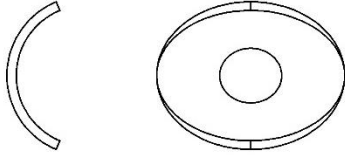
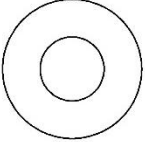
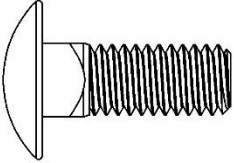
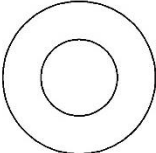
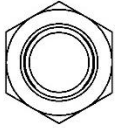
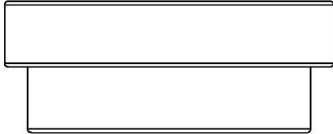
ITEM NO.	TO SCALE	PART NUMBER	DESCRIPTION	QTY.
1		92356A581	.312-18 x .75 Carriage SS	4
2		92356A582	.312-18 x 1.75 Carriage SS	7
3		92198A694	.312-18 x 2.75 HH SS	1
4		96659A107	.312 Flat Washer SS	12
5		91831A030	.312-18 Nyloc SS	12
6		5/16" Contour Washer	.312 Curved Washer	1
7		.06x.34x.75 Nylon Washer	.06 x .34 x .75 Nylon Washer	1
8		92356A624	.375-16 x 1 Carriage SS	3
9		96659A108	.375 Flat Washer SS	3
10		91831A127	.375-16 Nyloc SS	3
11		bushing	11-03013	2
			Anti-Seeze	1
			E6000	1

Assembly Instructions

Step 1 – Assembly of Foot (*Foot and Hardware will come in mount kit*)

- Measure width between previously installed rails.
- On the cross bows, use the slots that correspond to the measured distance between rails.
- Bolt feet to bows as shown, DO NOT TIGHTEN at this point.
- Feet can be installed as shown or reverse depending on how you mounted the rail.
- Use a 3/8 x .75 hex head bolt, 3/8 lock washers and a 3/8 flat washer to bolt foot to crossmember. Snug Tighten, but allow movement.

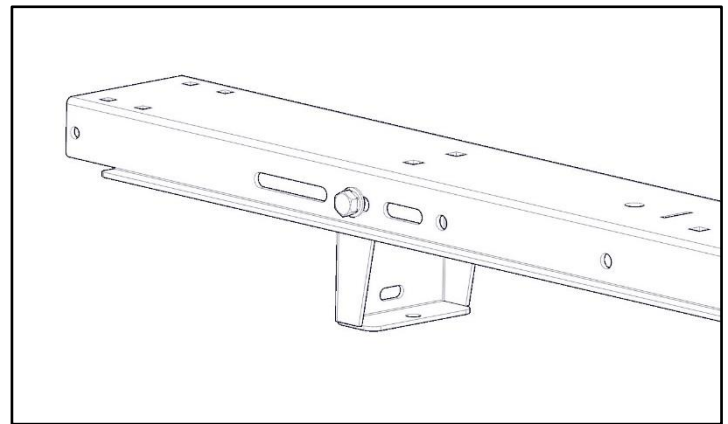
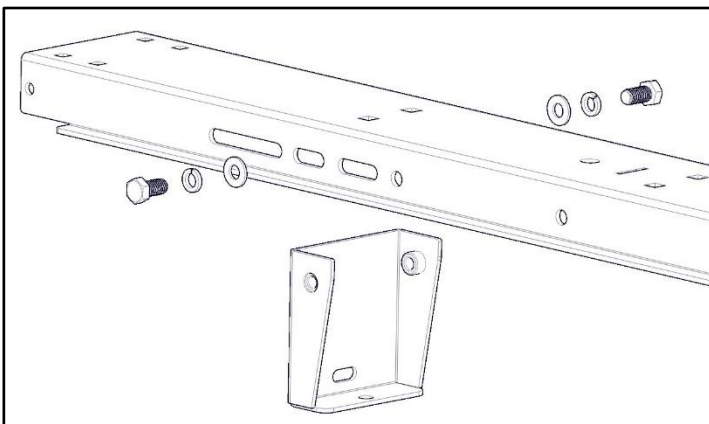
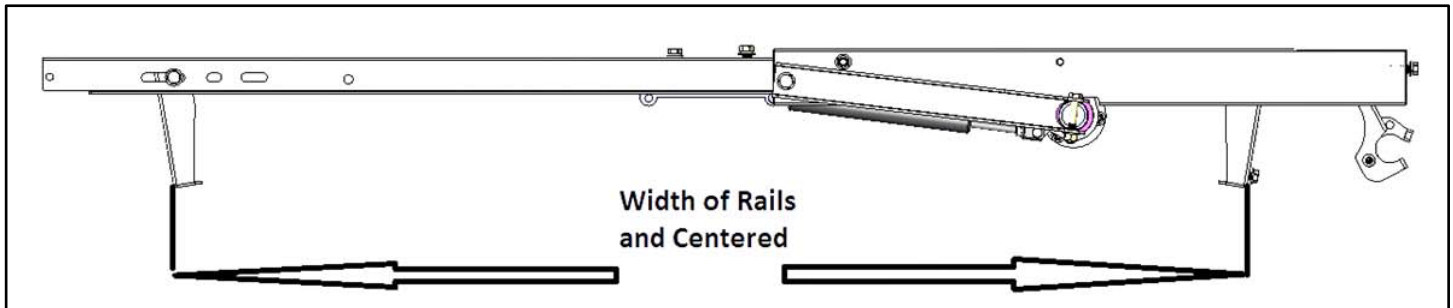

Step 2 – Ladder Stops

- Bolt ladder hooks to one end of each bow.
- Use a 5/16 carriage bolt, 5/16 washers and a 5/16 nylock.
- TIGHTEN. Skip if adding 4A813.

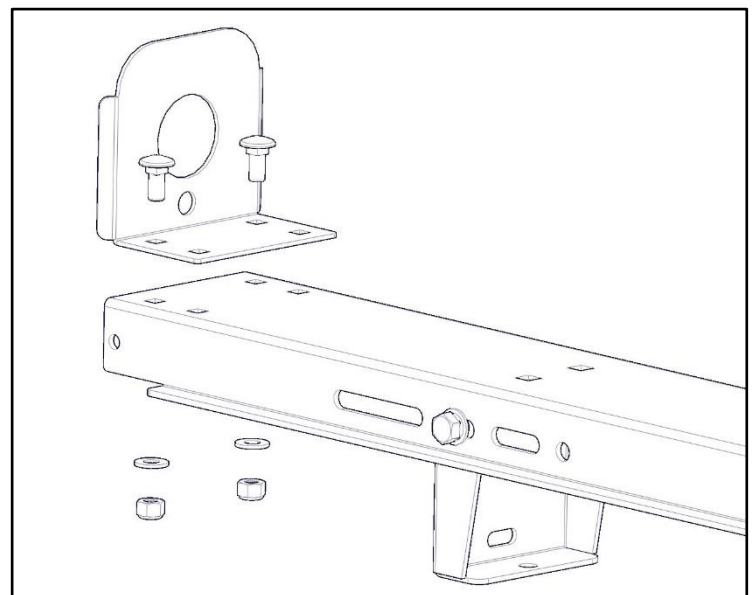
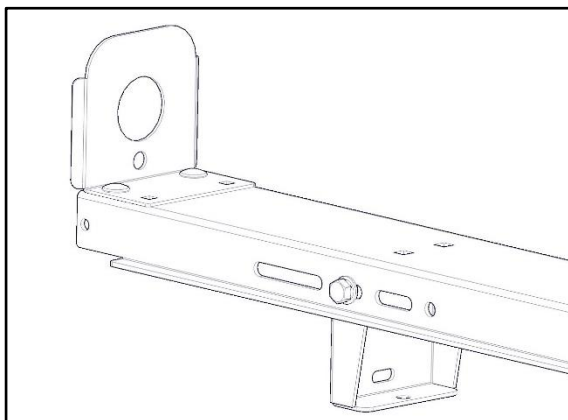

Step 3 – Mount to Rails

- Place both bows on top of installed rails. Bolt feet to rails using 5/16 x 1 HH, two 5/16 flat washers and a 5/16 nylock nut
- Put the ladder hooks on the driver side of vehicle.
- Snug Tighten, but allow movement.

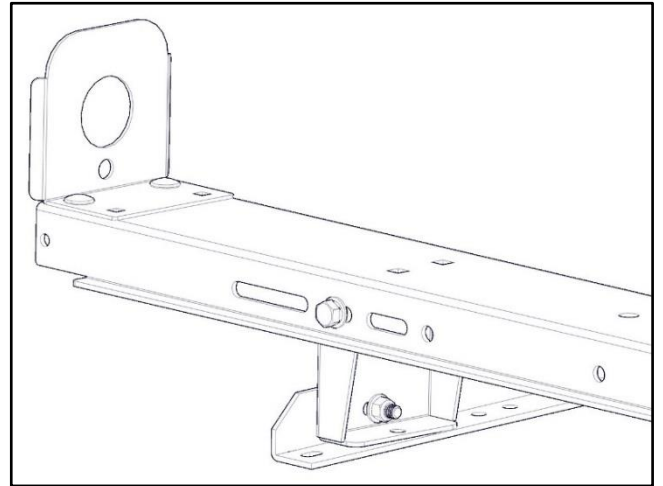
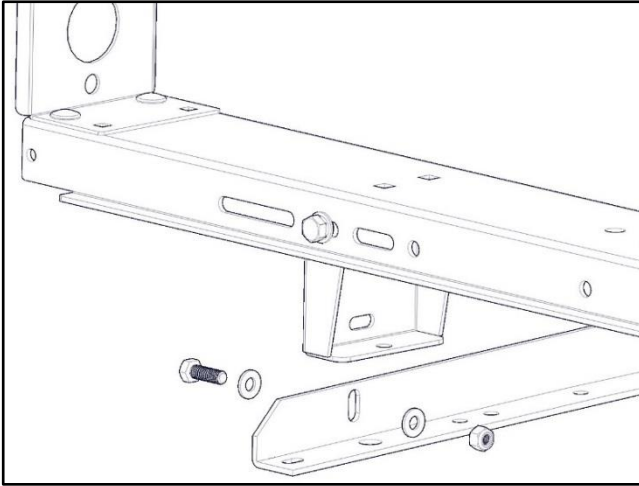

Step 4 – Mount Side Tube

- Place side tube on top of installed bows.
- Have the bend towards the front of the vehicle as shown.
- Mount rotation bar plate to the rear of the tube as shown.
- Leave one square slot open at the rear of the side tube.
- Bolt together using 5/16 x 1.75 carriage bolt, a 5/16 flat washer and a 5/16 nylock.
- Snug Tighten, but allow movement.

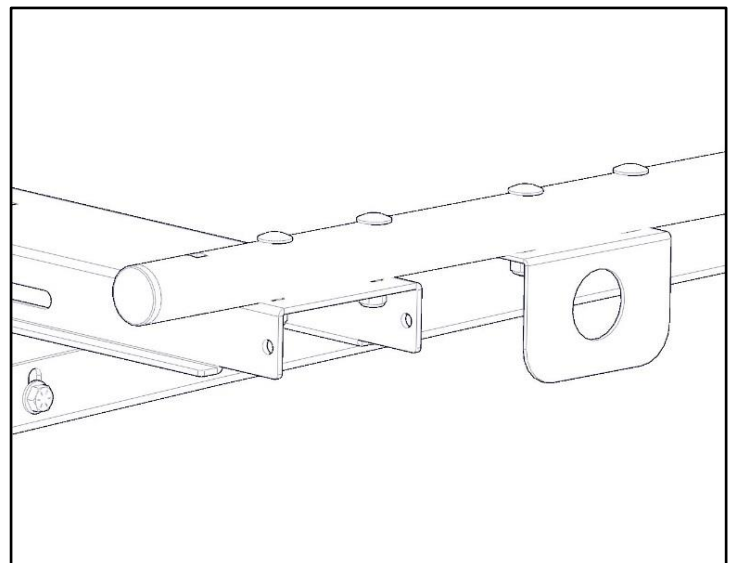
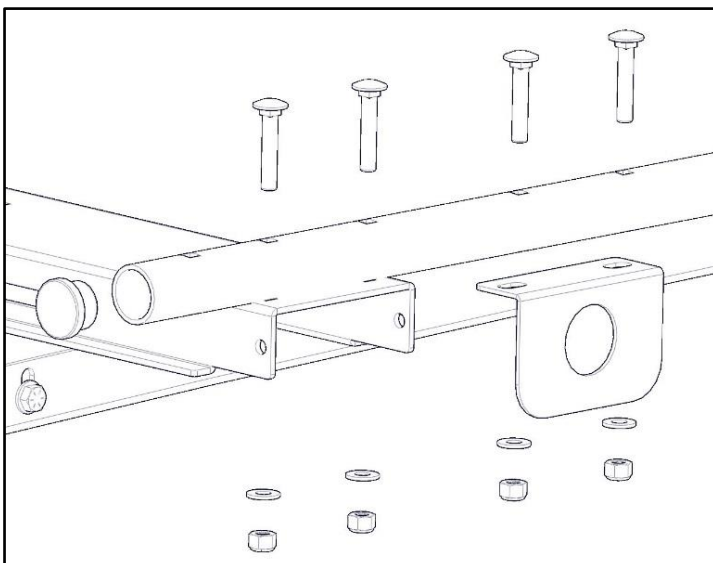
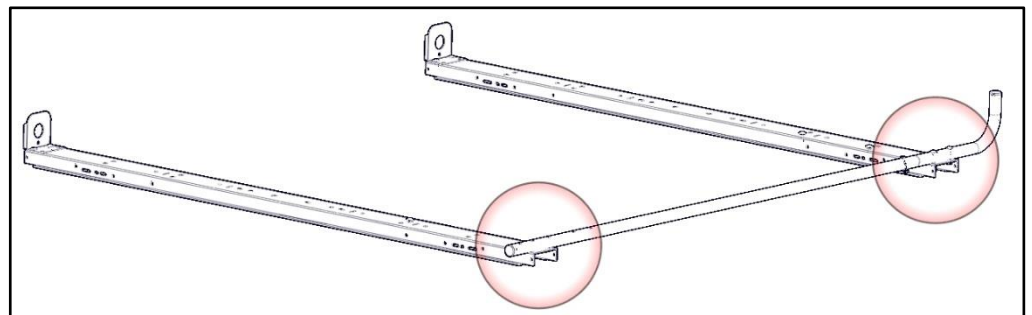

Step 5 – Mount Clamp Tube

- Place clamp and lock L bracket on top of installed bows.

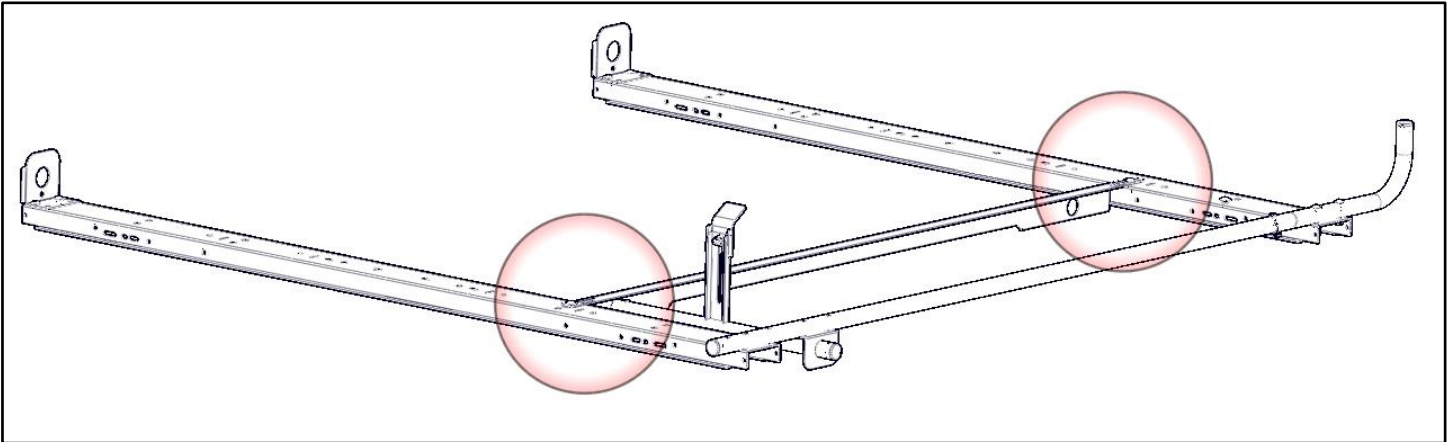

- Insert plastic bushings into the clamp and lock L bracket and the rotation bar plate installed in Step 4, with flange towards each other and to the inside as shown.

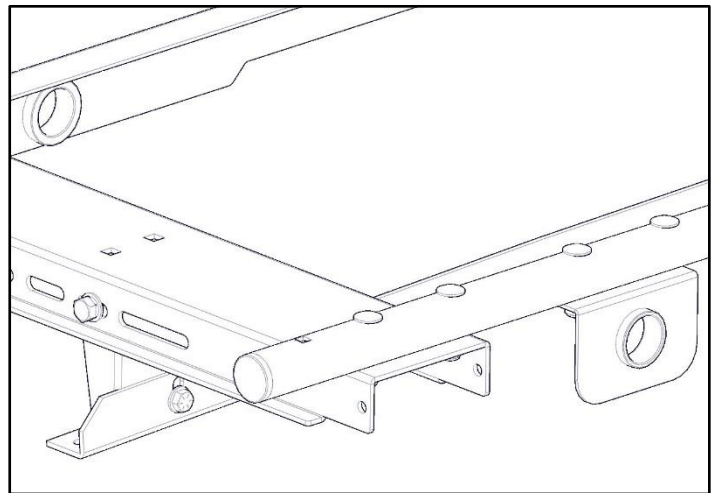
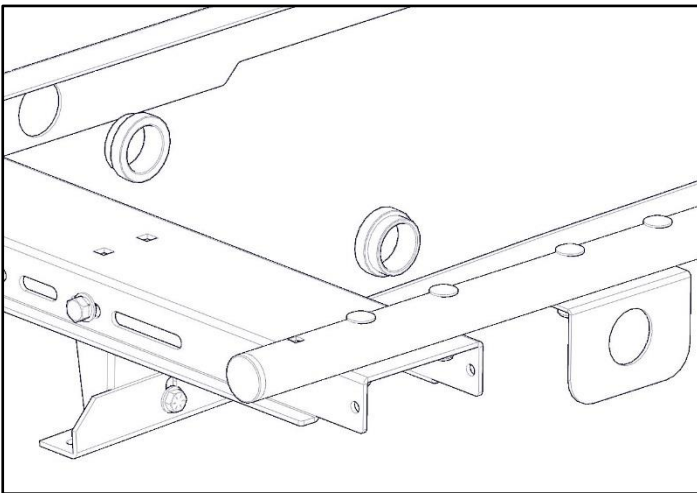

- Insert clamp tube into both plastic bushings.
- Adjust clamp on clamp tube to fit firmly against your ladder.

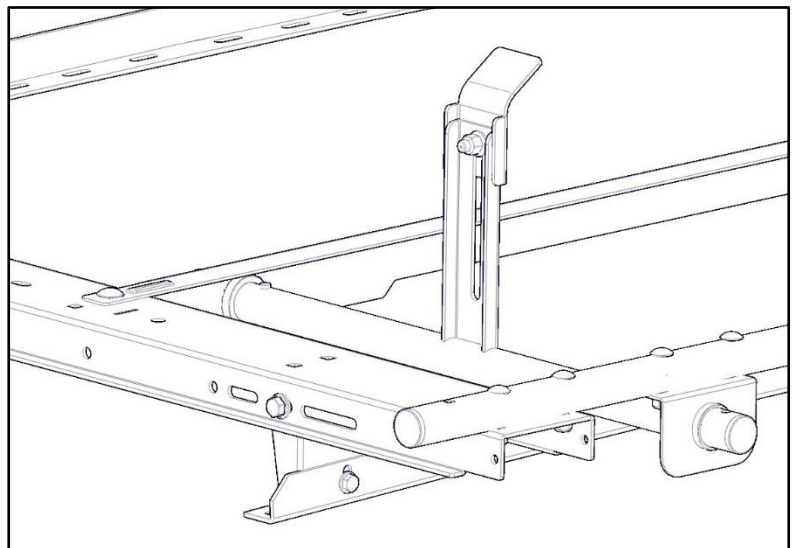
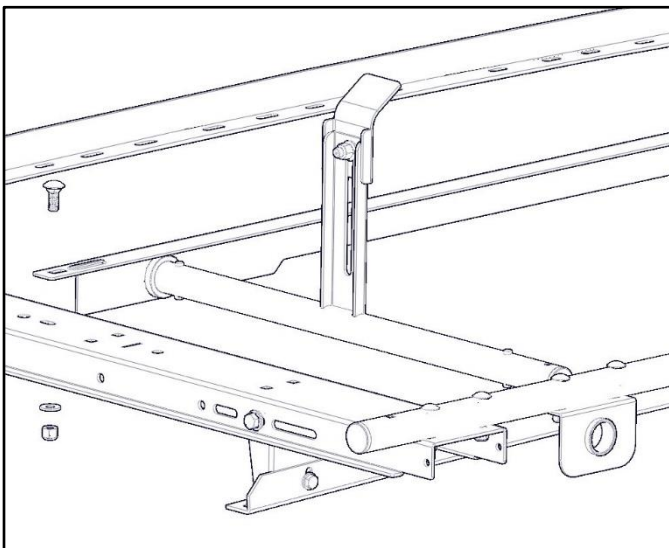

- Bolt clamp and lock L bracket to bows using 3/8 x 1 carriage bolt, 3/8 flat washer and a 3/8 nylock as shown. (This view shown without clamp tube)
- TIGHTEN

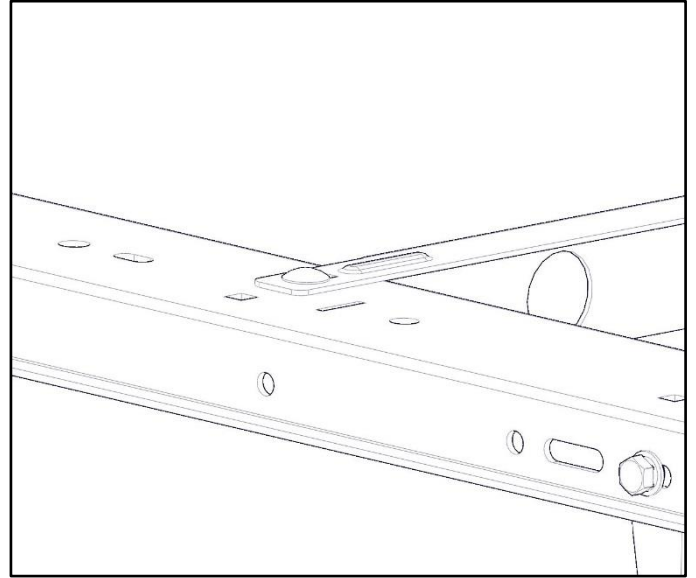
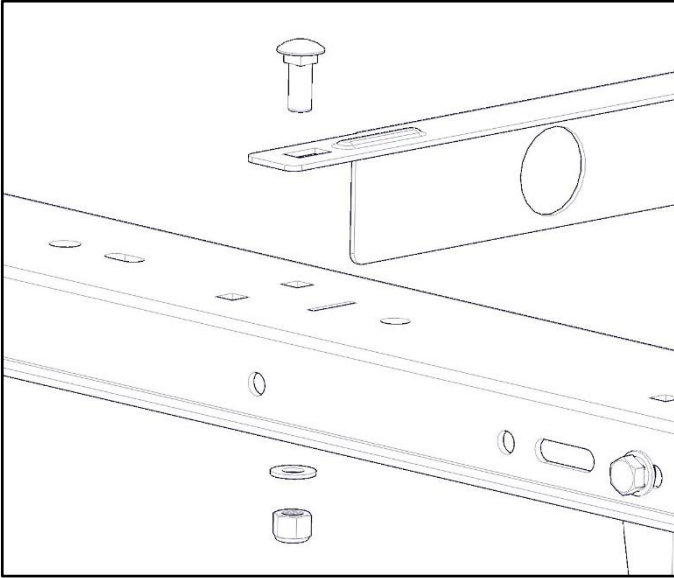

Step 6 – Mount Handle

- Bolt handle to clamp tube using a 5/16 x 2.75 hex head, two 5/16 flat washers, 5/16 nylon washer and 5/16 a nylock. The nylon washer goes in between the clamp tube and handle.
- TIGHTEN

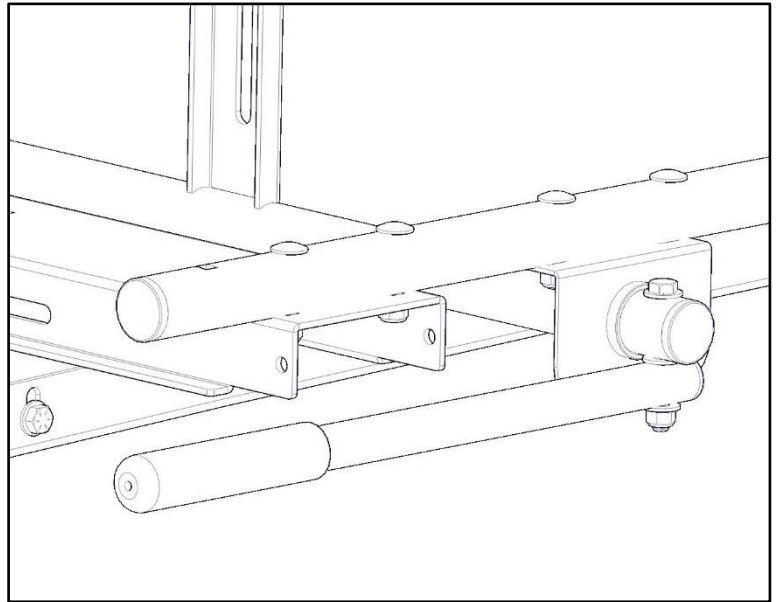
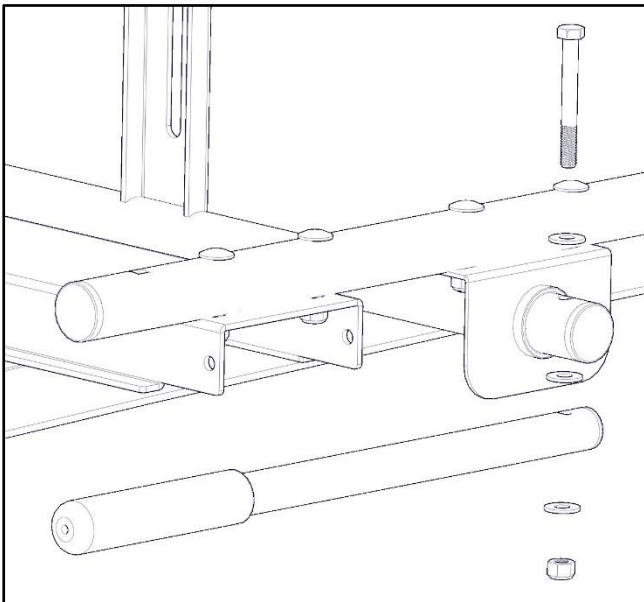

Step 7 – Mount Latch Assembly

- Bolt latch to the rear of the mount tube that was installed in Step 5 using 5/16 x 1.75 carriage bolt, 5/16 curved washer and a 5/16 nylock.
- TIGHTEN

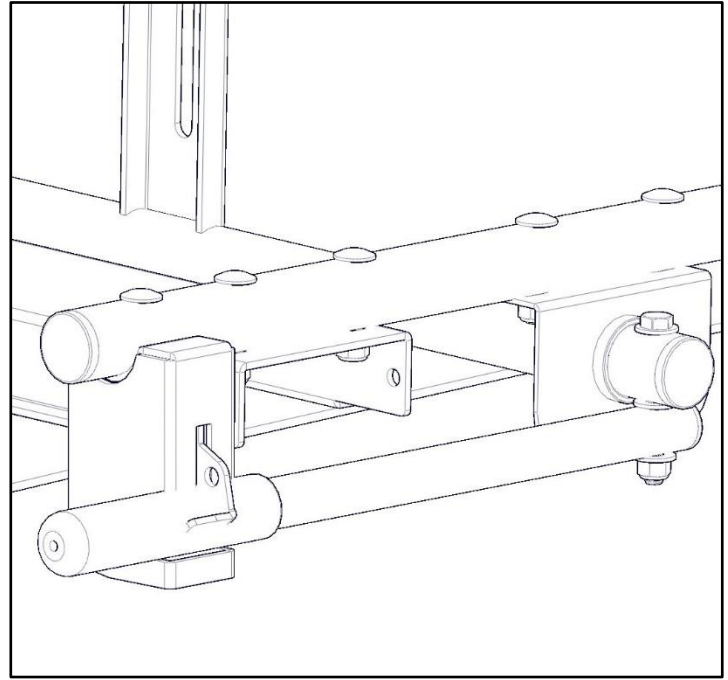
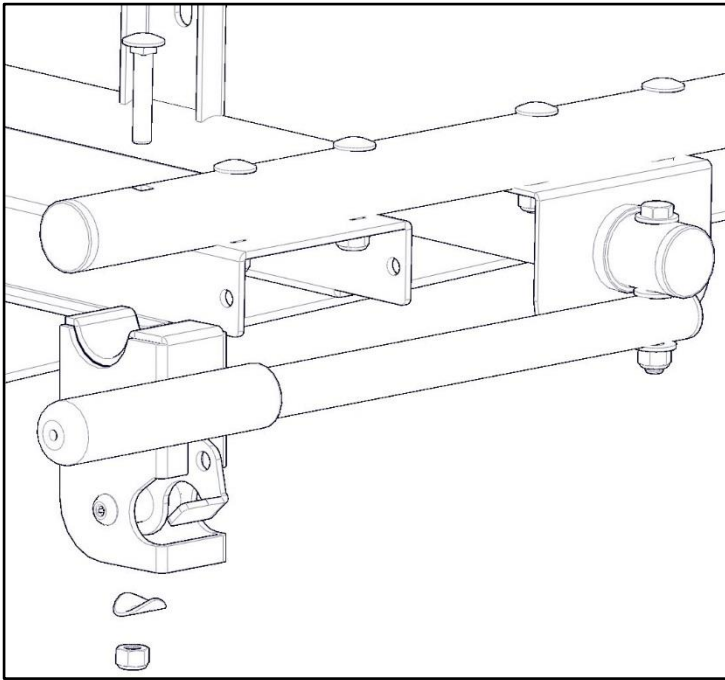

Step 8 – Mount Ladder Hook Bracket to Bow

- Bolt ladder hook bracket to the bow in the orientation shown using a 3/8 x 1 carriage bolt, a 3/8 flat washer and a 3/8 nylock. Be sure the bracket is square to the bow.
- Adjust clamp on bracket to fit firmly against your ladder.
- TIGHTEN

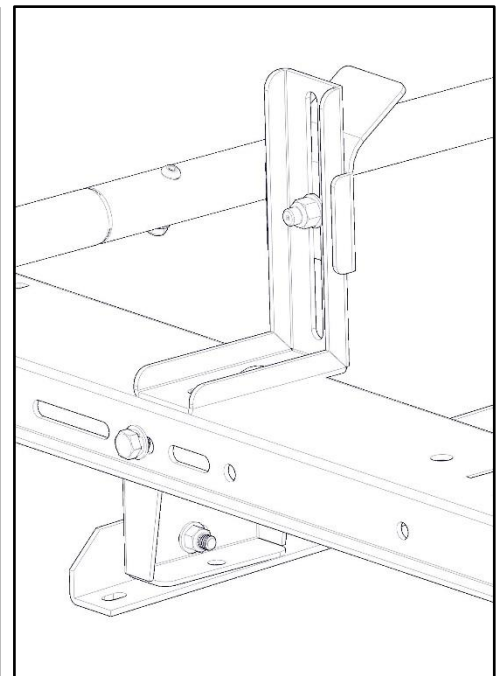
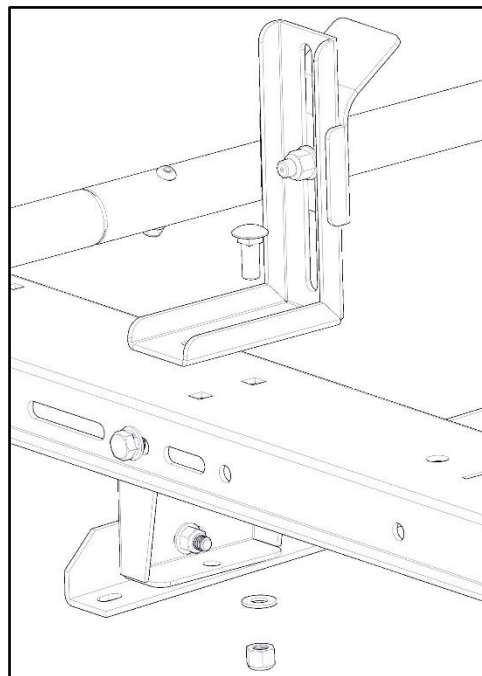

GO BACK AND ENSURE ALL HARDWARE IS TIGHT
Your installation is now complete.