

KARGO MASTER[®]

WE PUT EVERYTHING WITHIN REACH.

Installation Instructions

4A821

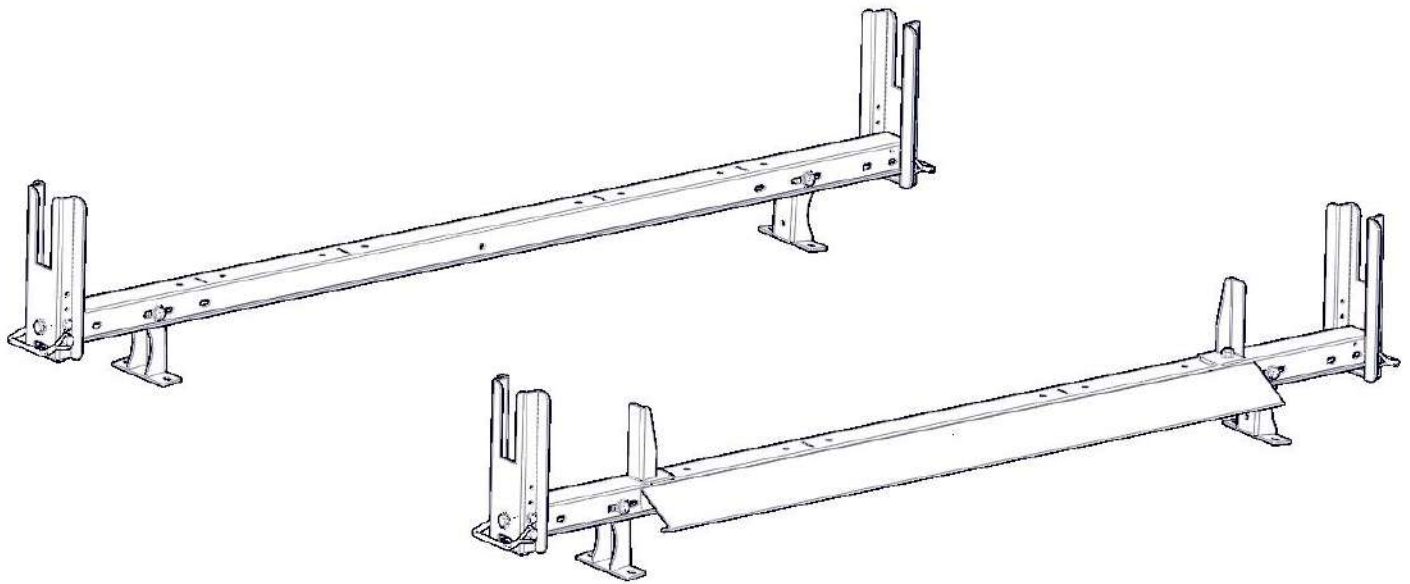

***PLEASE READ ALL INSTRUCTIONS AND WARNINGS PRIOR TO ASSEMBLING,
INSTALLING, AND USING THIS PRODUCT***

Warning

Always check for wires, fuel tanks and lines, brake lines and other important vehicle functionality items prior to drilling and installing all products.



Tools Needed

9/16" Socket and Wrench	7/16" Socket and Wrench
13mm Socket and Wrench	10mm Socket and Wrench

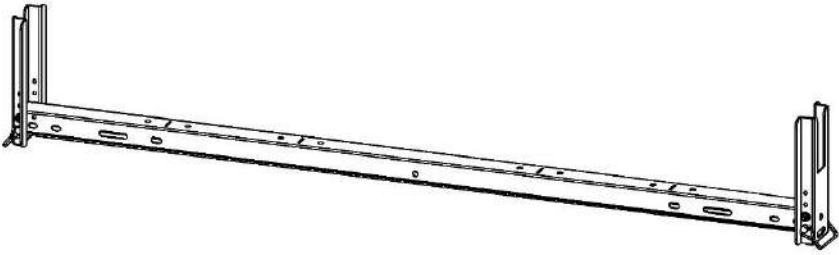
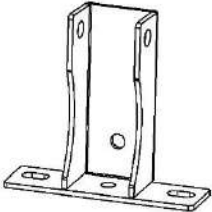

Before You Begin

- Read all instructions.
- Be sure to put E6000 sealant around all threads entering cargo area and between the rubber spacer and roof of vehicle to prevent water from leaking into cargo area.
- Be sure to apply Anti-Seeze to all stainless-steel threads.

Parts

ITEM NO.		PART NUMBER	QTY.
A		4A821-10	2
B		4A821-10-001	4
C		4A821-10-006	2
D		4A821-10-009	1

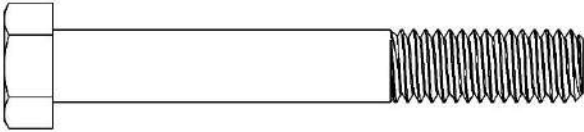
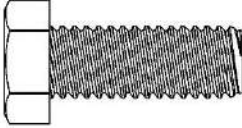
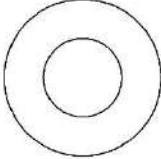
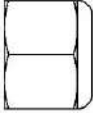
Assembly Hardware (18-4A821)

ITEM NO.		DESCRIPTION	QTY.
1		.375-16 x 2.75 HH	4
2		.375-16 x 1 HH	9
3		.375 Flat Washer	26
4		.375-16 Nyloc	13
5		.375 x 1.5 Nylon Spacer	4

Step 1 – Adjustment of Uprights

- If van upright is not at desired height, Remove bolts and adjust accordingly.
- The van upright can vary in height, be sure to have one hole open below where van upright is bolted to crossmember.
- Repeat on other side of crossmember.
- Repeat on other crossmember. You will have two of the same assemblies.
- Insert pin snapper through the van upright and the crossmember (B). Use the open hole below the previously installed hex bolt.
- TIGHTEN

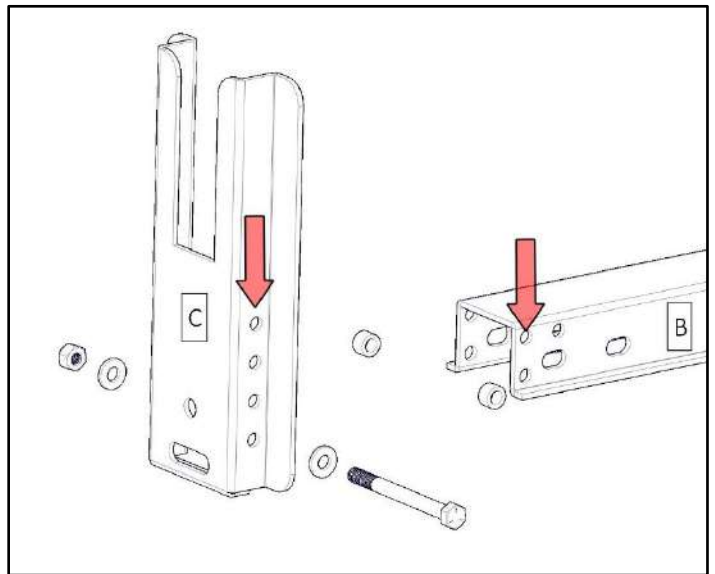

Below shows different heights of van uprights

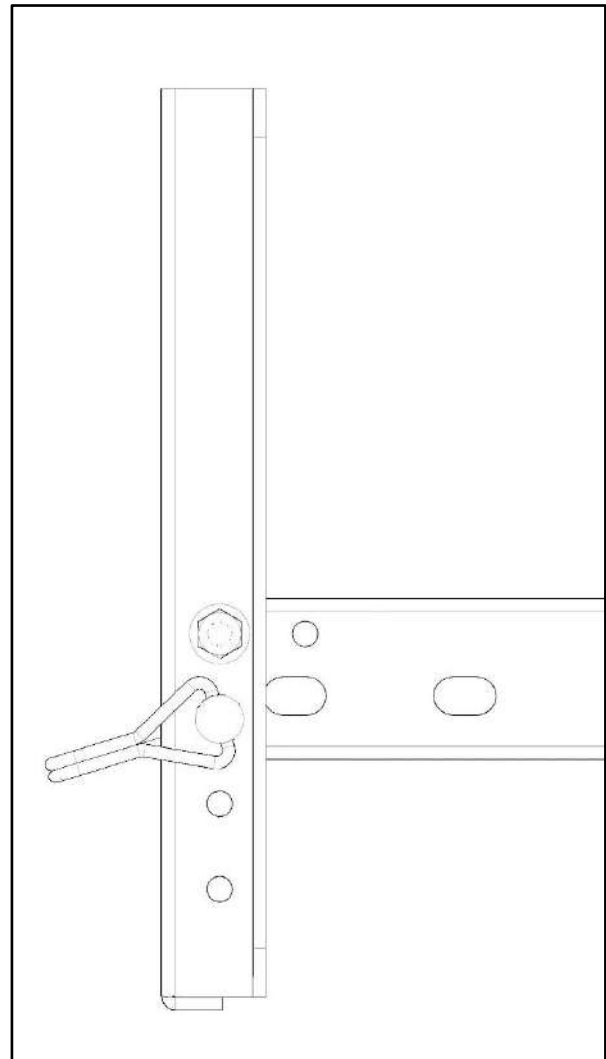
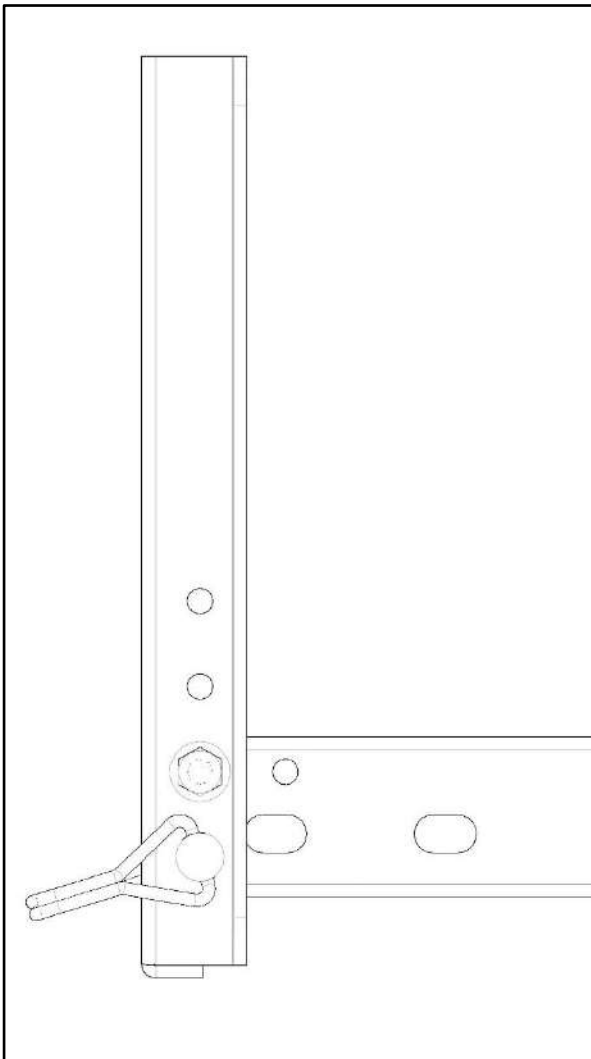

Step 2 – Assemble Ladder Hooks

- On one cross member (A), bolt two ladder hooks (C) to the top of cross member using one 3/8" x 1" hex head (2) two 3/8" flat washers (3) and one 3/8" NYLOC nut (4).
- The tab on the ladder hook will line up with the slot in the crossmember
- Typically, this cross member goes to the front of the vehicle.
- Be sure to apply Anti-Seeze to all threads.
- TIGHTEN

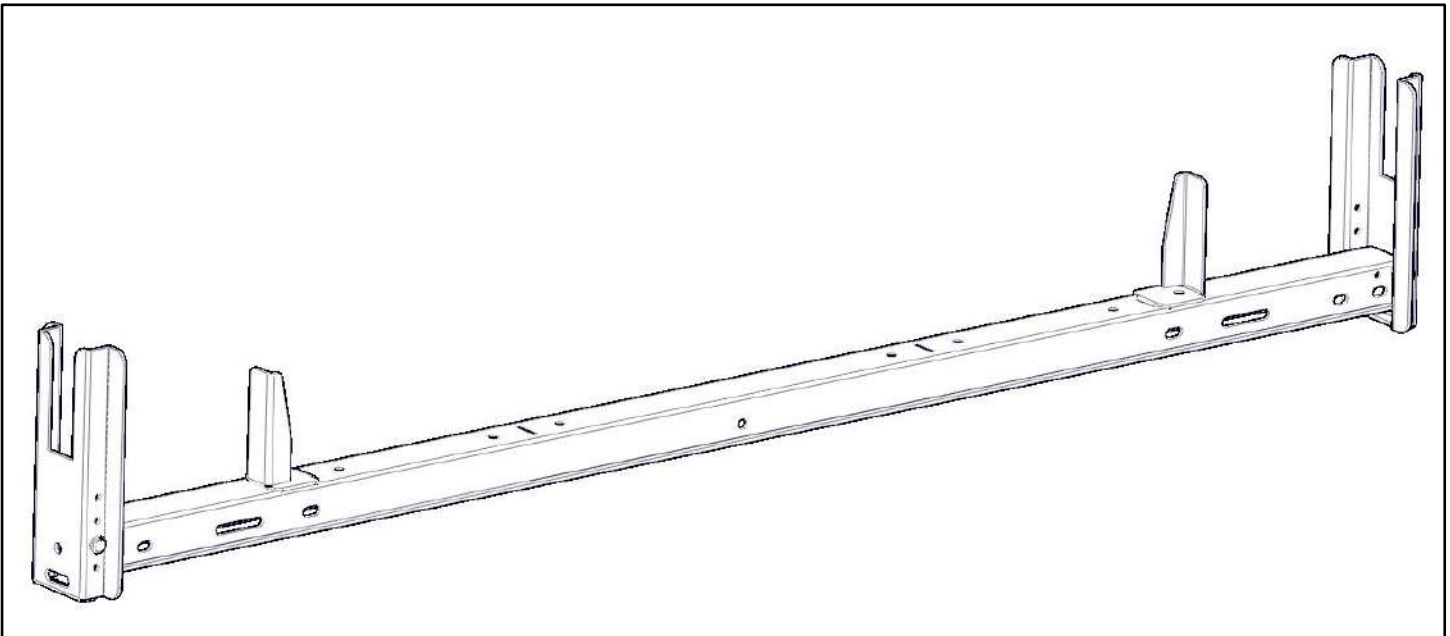
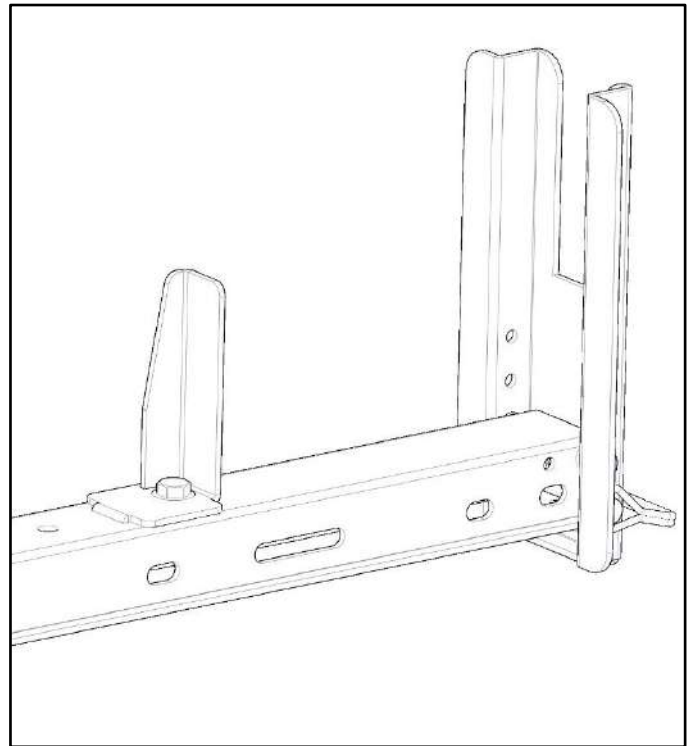
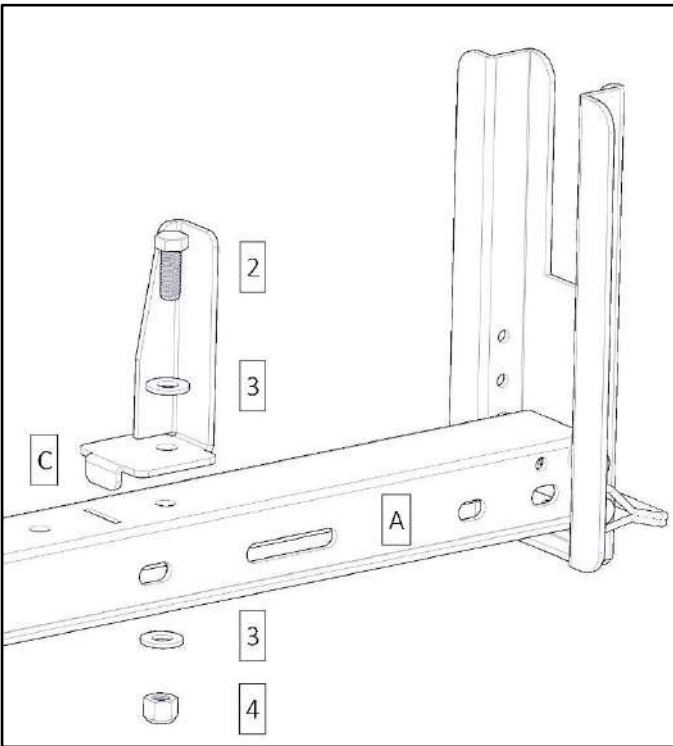

Step 3 – Assemble Wind Deflector

- Bolt wind deflector (D) to the front of the cross member (A) through the slot as shown below. Typically this is attached to the same cross member with the ladder hooks.
- Use a 3/8" x 1" hex head bolt (2), a 3/8" flat washer (3) and a 3/8" nyloc nut (4) in the order shown. Be sure to apply Anti-Seeze to all threads.

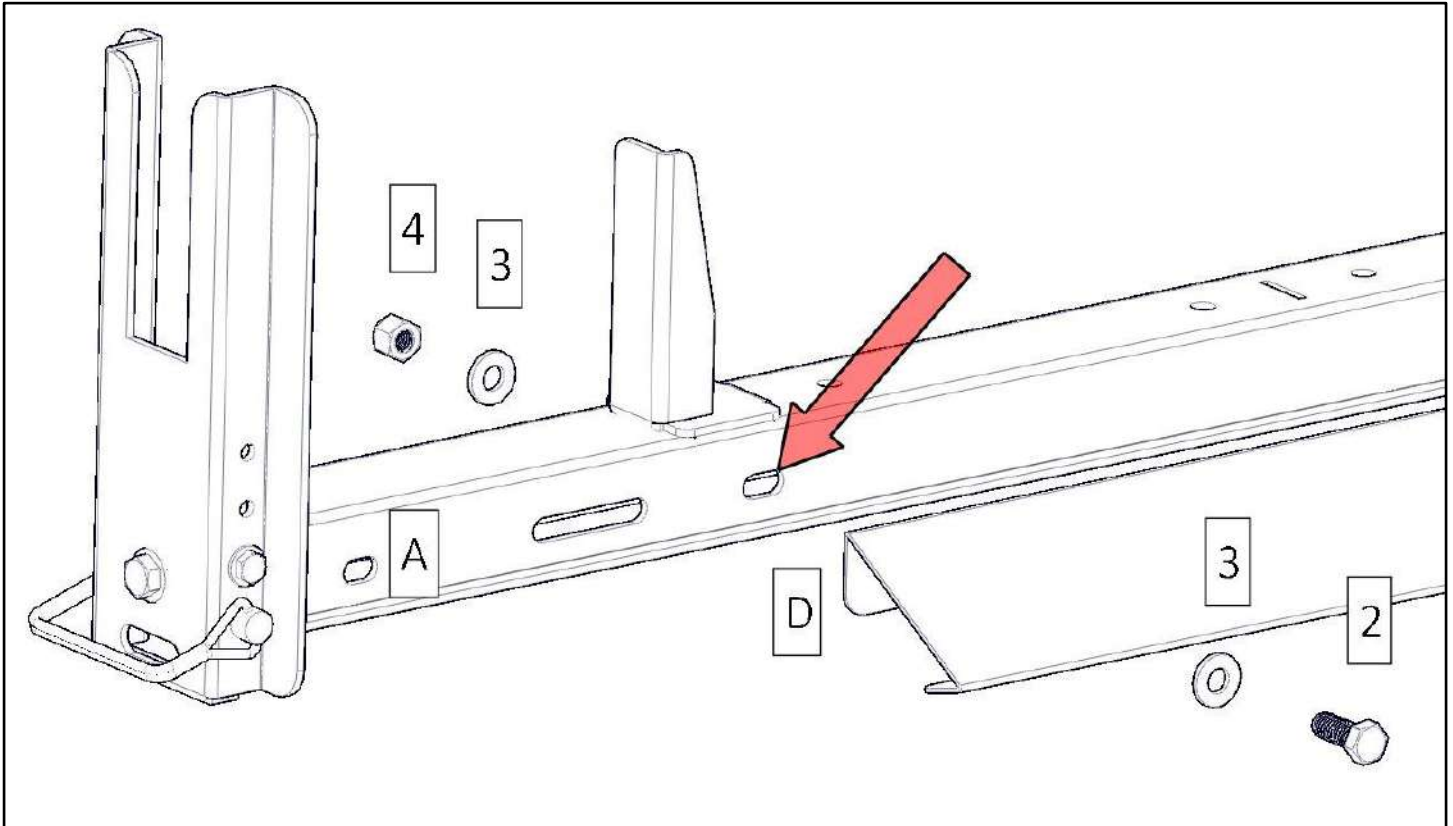

- Repeat in other two locations as shown.

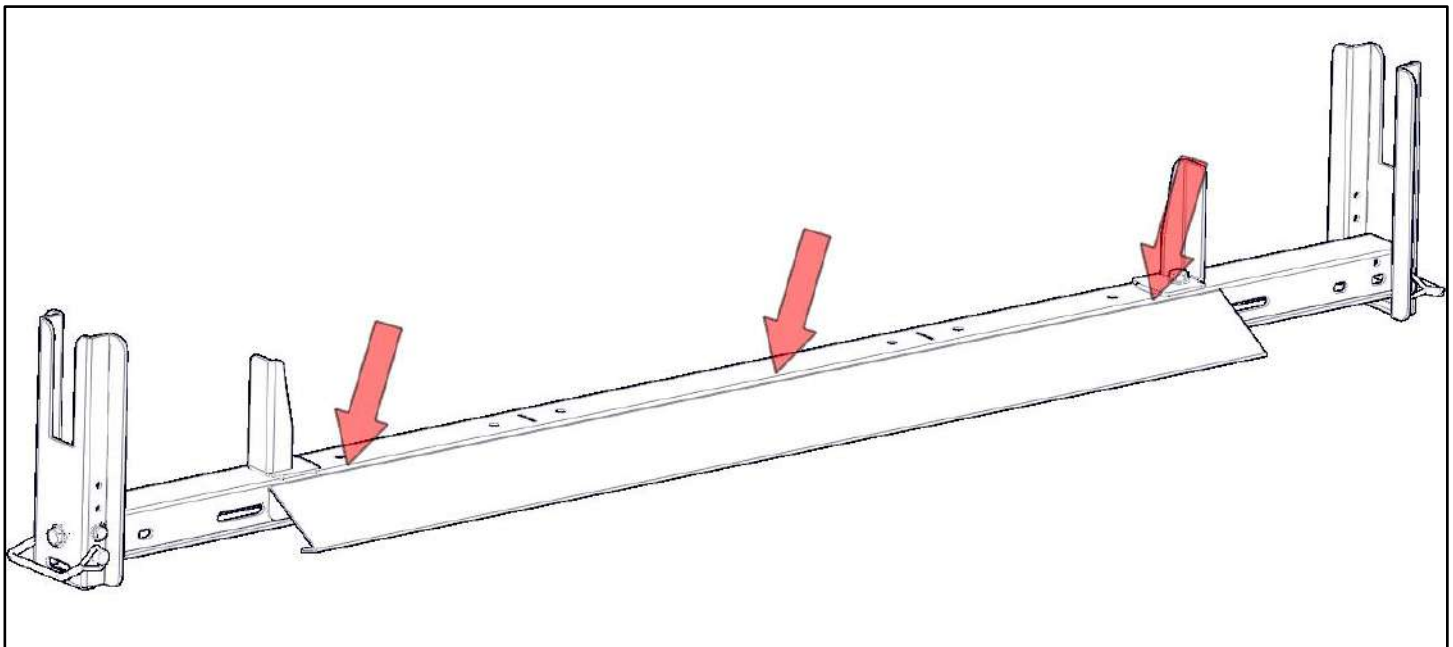

- Square and TIGHTEN

Step 4 – Assembly of Foot

- Depending on your vehicle, the foot will mount in different slots.

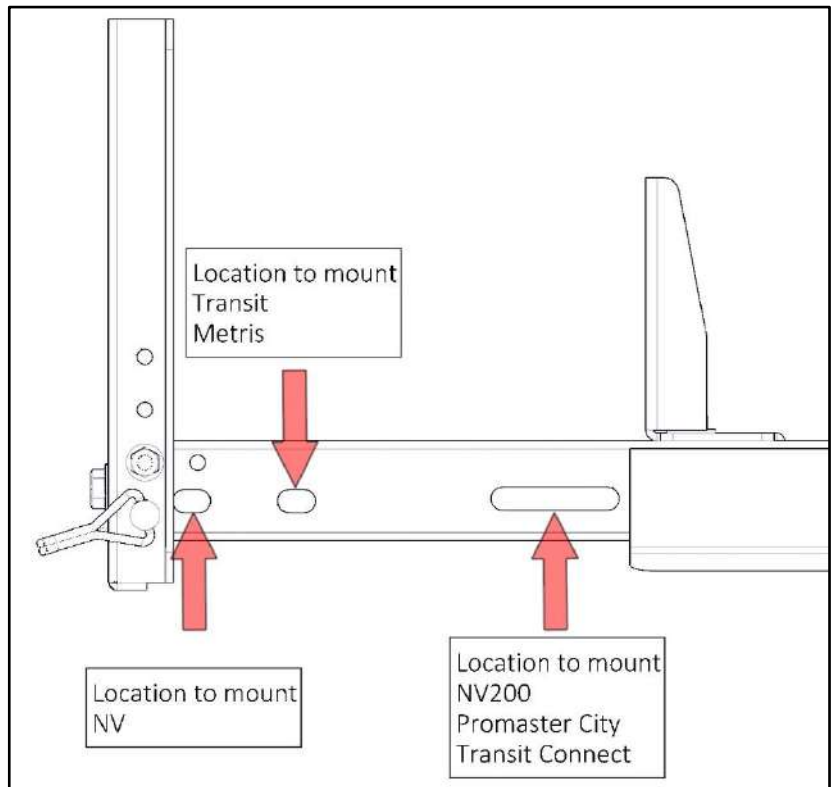

- Use a 3/8" x 2.75" hex head bolt (1), two 3/8" flat washers (3) and a 3/8" nyloc nut (4) to bolt foot (B) to crossmember (A). Be sure to insert the nylon spacer (5) inside foot.
- Have the cup in the foot facing outward. (as shown)
- Repeat on both sides and both crossmembers
- Do NOT tighten. Be sure to apply Anti-Seeze to all threads.

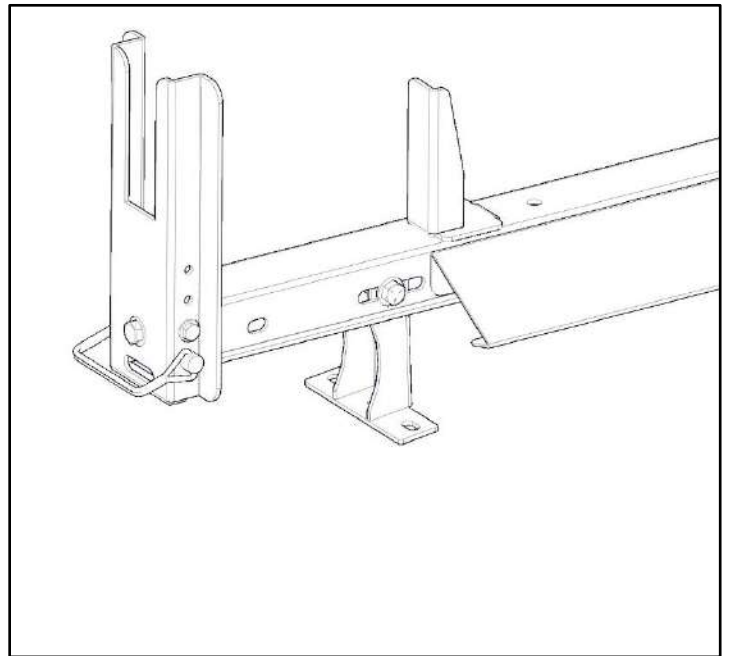
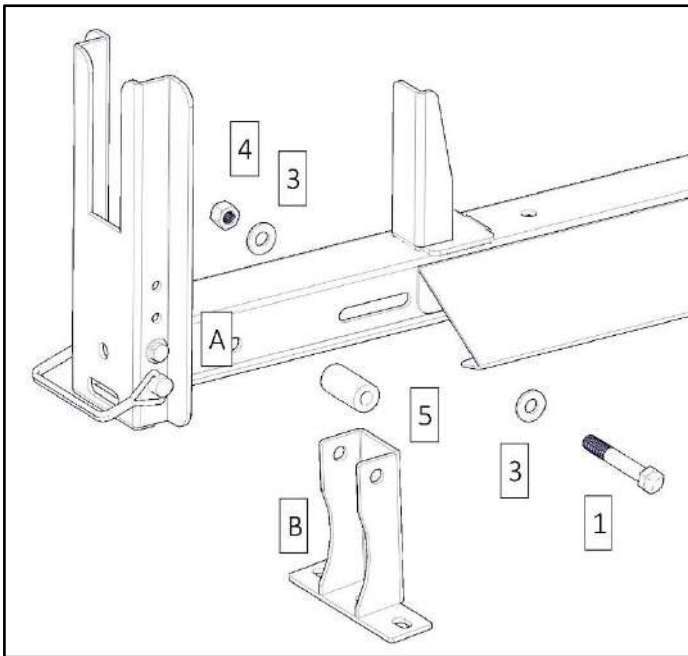



Installation onto van

Typically the assembly with the ladder hook goes towards the front of the vehicle.
Follow your vehicles instructions below.

Installation Instructions

Find vehicle below, follow instructions from there.

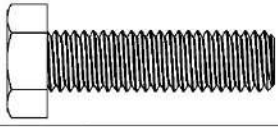
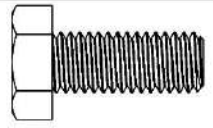
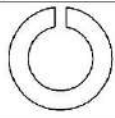
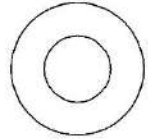
Installation Hardware (To Scale) (18-4M821)

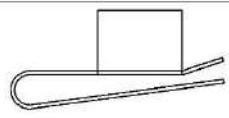
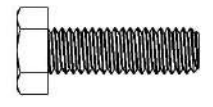
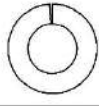
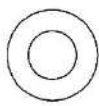
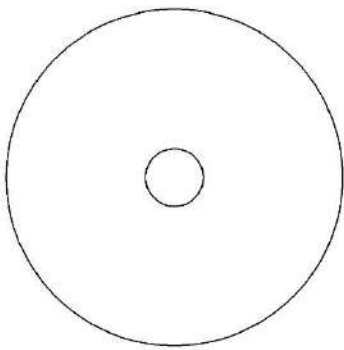
ITEM NO.		DESCRIPTION	QTY.
6		M8x30 HH	4
7		M8x20 HH	8
8		M8 Split Lock Washer	8
9		M8 Flat Washer	12
10		M8 Nylock Nut	4
11		M8 U-Nut	8
12		M6x20 HH	8
13		M6 Split Lock Washer	8
14		M6 Flat Washer	8
15		.125x.312x1.75 Rubber Washer	4

Installation Hardware (con't)

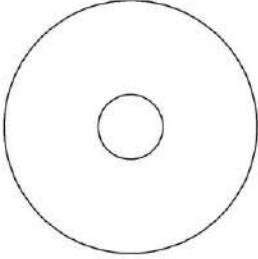
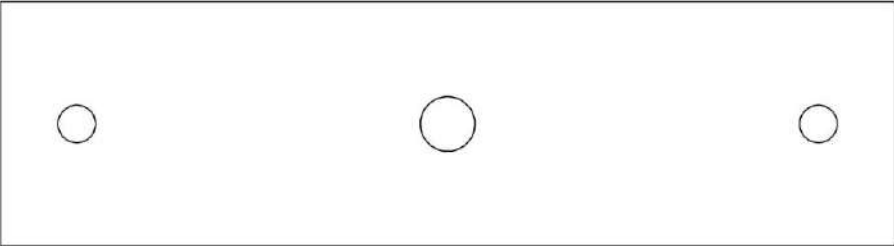
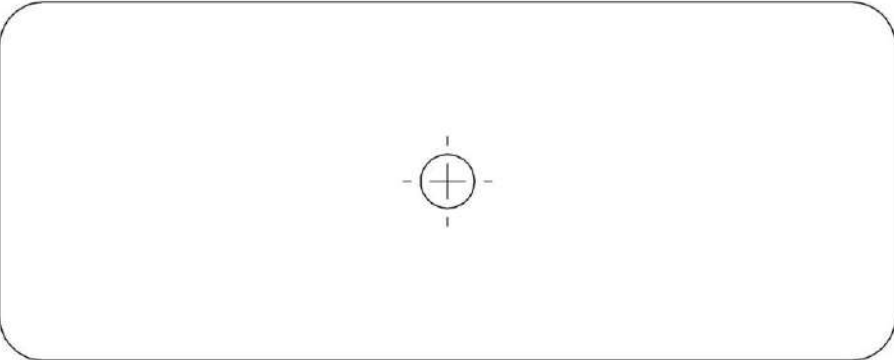
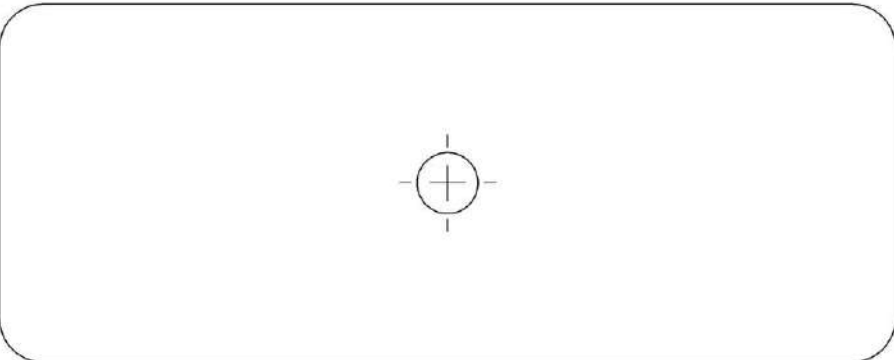
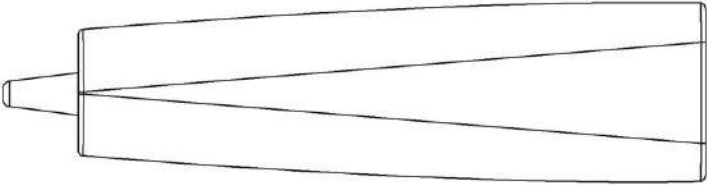
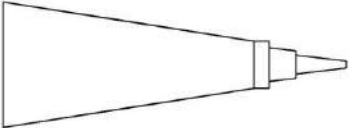
ITEM NO.		DESCRIPTION	QTY.
16		.312 Fender Washer	4
17		40821-10-004-R1	4
18		T249-02-R1	4
19		T250A-01	4
20		E6000	1
21		Anti-Seeze	1

Transit Connect

Step 1

- Remove plugs from desired mounting location in the roof of van.

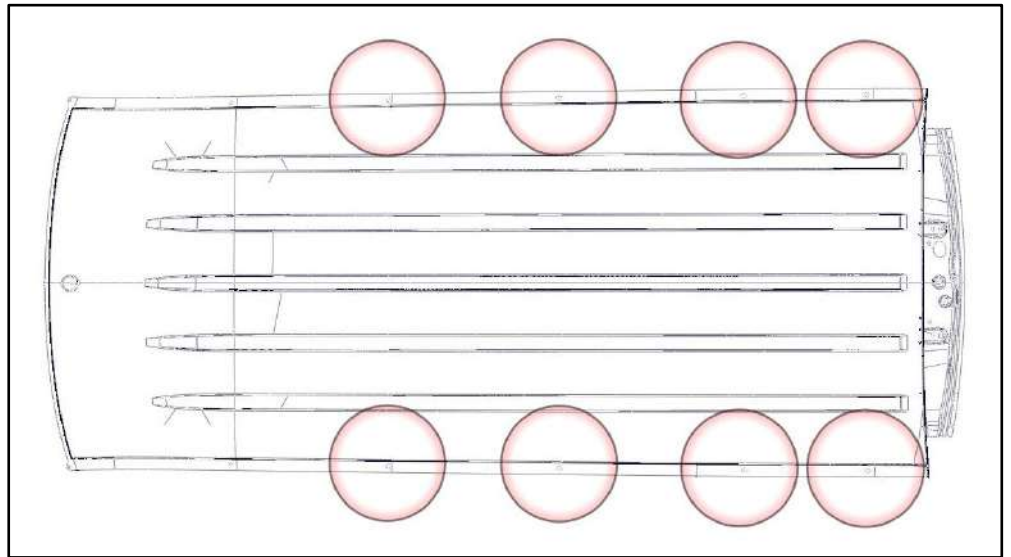

Step 2

- Bolt through the mount foot (B) into the exposed holes in roof using one M8 x 30mm hex head (6), one M8 flat washer (9), a rubber spacer (17), a rubber washer (15), one fender washer (16) and one M8 nylock nut (10). In the order shown.
- Be sure to put rubber spacer (17) in between mount foot (B) and roof of van as shown below.
- The roof goes in between rubber spacer (17) and rubber washer (15)
- Place E6000 between rubber spacer and roof of van and around threads to ensure no water leaks into van. Be sure to apply Anti-Seeze to all threads.

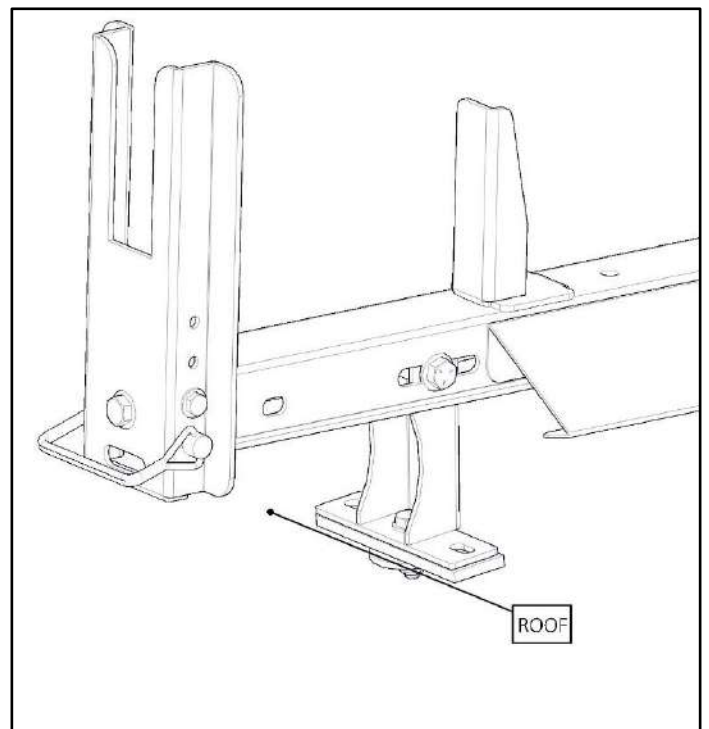
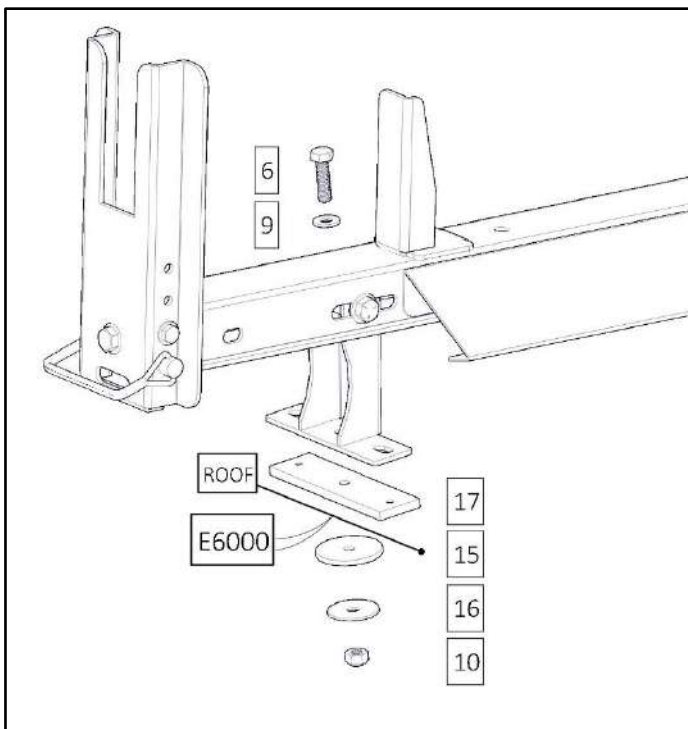

Step 3

- Go back and tighten all bolts including nuts and bolts on the rack itself.

Transit

Step 1 -

- Remove plugs from desired mounting location in the roof of van.

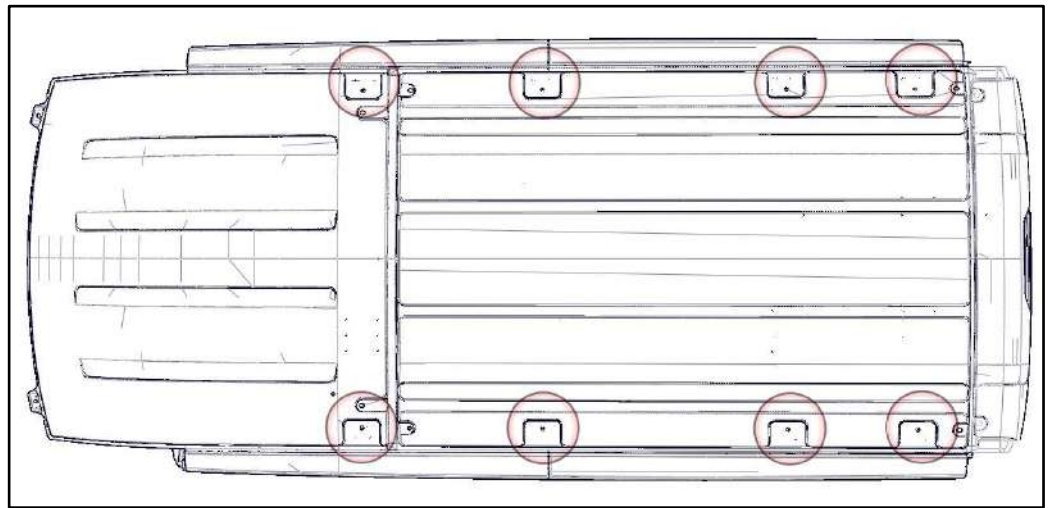

Step 2

- Bolt through the mount foot (B) into the exposed holes in roof using one M8 x 30mm hex head (6), one M8 lock washer (8), one M8 flat washer (9), a metal plate (19) and a rubber pad (18). In the order shown.
- Be sure to put rubber pad (18) and metal plate (19) in between mount foot (B) and roof of van as shown below. The rubber pad goes on the roof.
- Place E6000 between rubber pad and roof of van and around threads to ensure no water leaks into van. Be sure to apply Anti-Seeze to all threads.

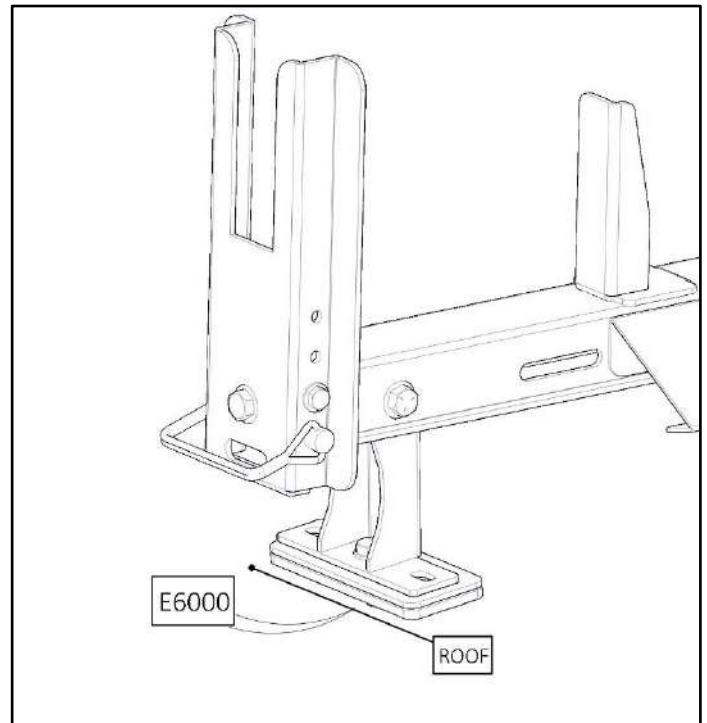
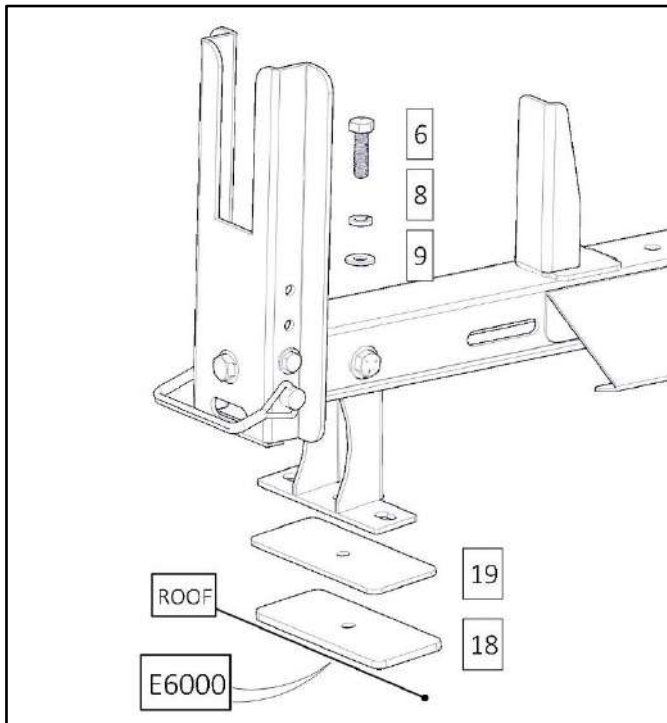

Step 3

- Go back and tighten all bolts including nuts and bolts on the rack itself.

Promaster City

Step 1

- Remove plugs from desired mounting location in the roof of van.

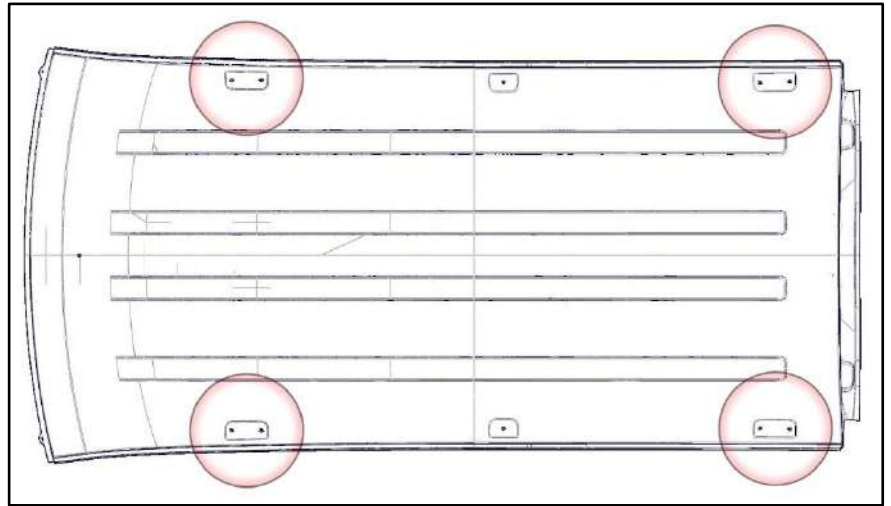

Step 2

- Bolt through the mount foot (B) into the exposed holes in roof using one M6 x 20mm hex head (12), one M6 lock washer (13), one M6 flat washer (14) and a rubber spacer (17). In the order shown.
- Be sure to put rubber spacer (17) in between mount foot (B) and roof of van as shown below.
- Place E6000 between rubber spacer and roof of van and around threads to ensure no water leaks into van. Be sure to apply Anti-Seeze to all threads.

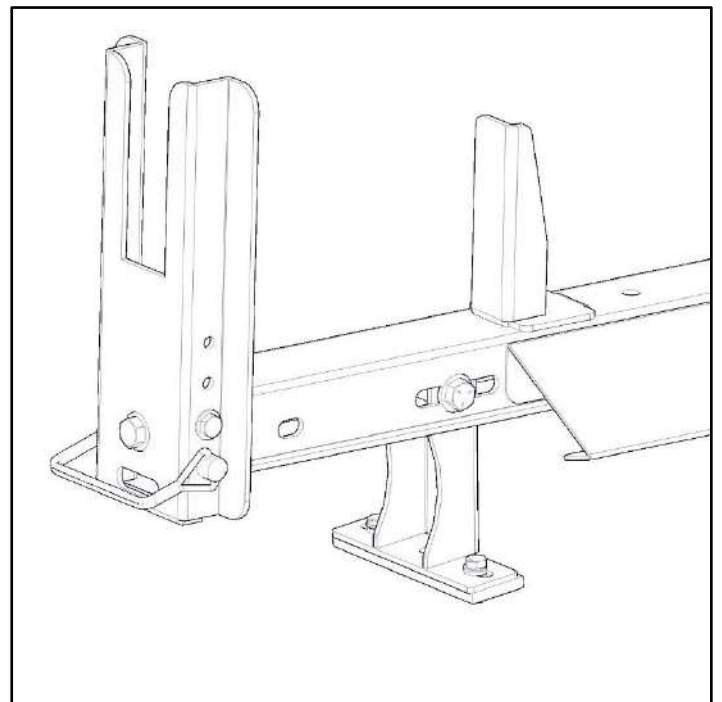
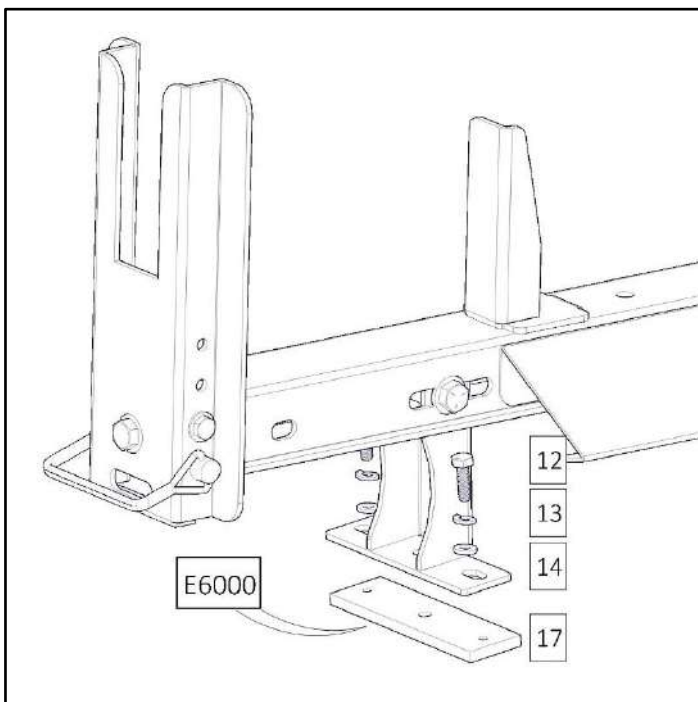

Step 3

- Go back and tighten all bolts including nuts and bolts on the rack itself.

NV200/Chevy City Express

Step 1

- Remove plugs from desired mounting location in the roof of van.

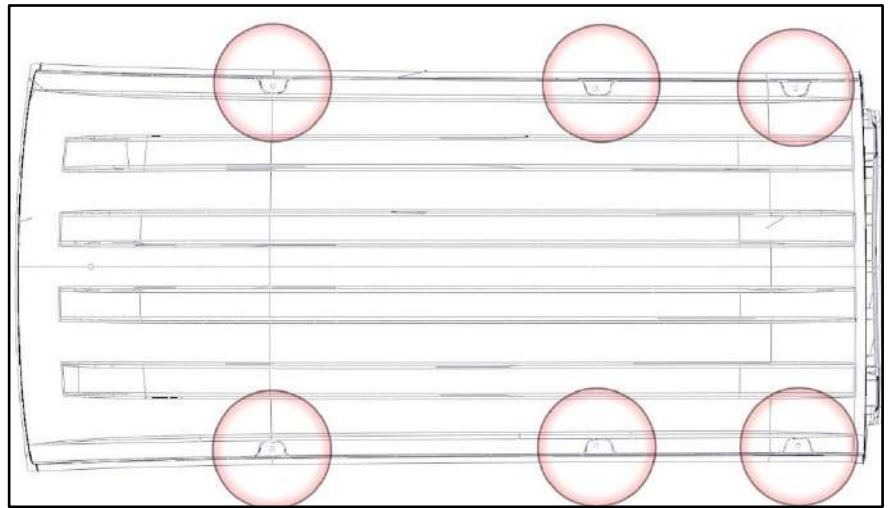

Step 2

- Bolt through the mount foot (B) into the exposed holes in roof using one M8 x 30mm hex head (6), one M8 lock washer (8), one M8 flat washer (9) and a rubber washer (16). In the order shown.
- Be sure to put rubber washer (16) in between mount foot (B) and roof of van as shown below.
- Place E6000 between rubber spacer and roof of van and around threads to ensure no water leaks into van. Be sure to apply Anti-Seeze to all threads.

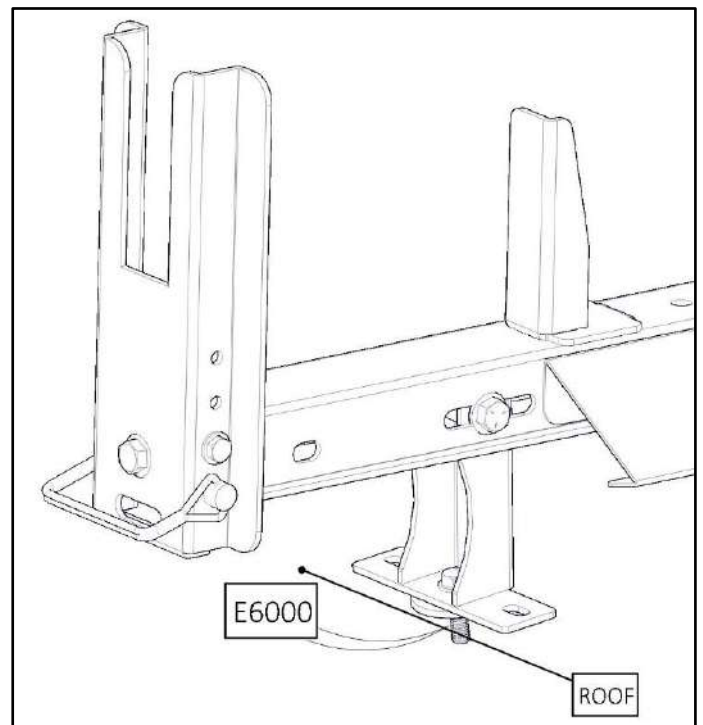
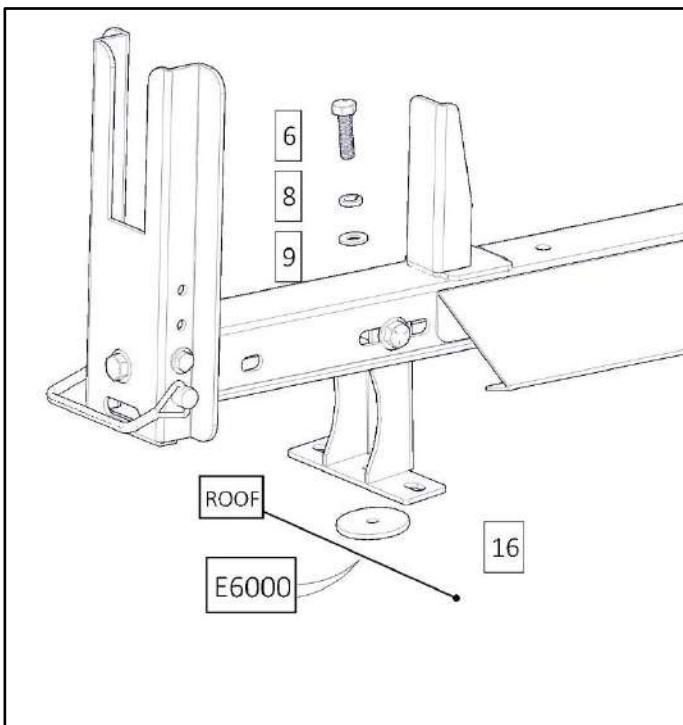

Step 3

- Go back and tighten all bolts including nuts and bolts on the rack itself.

Metris

Step 1

- Remove plugs from desired mounting location in the roof of van.

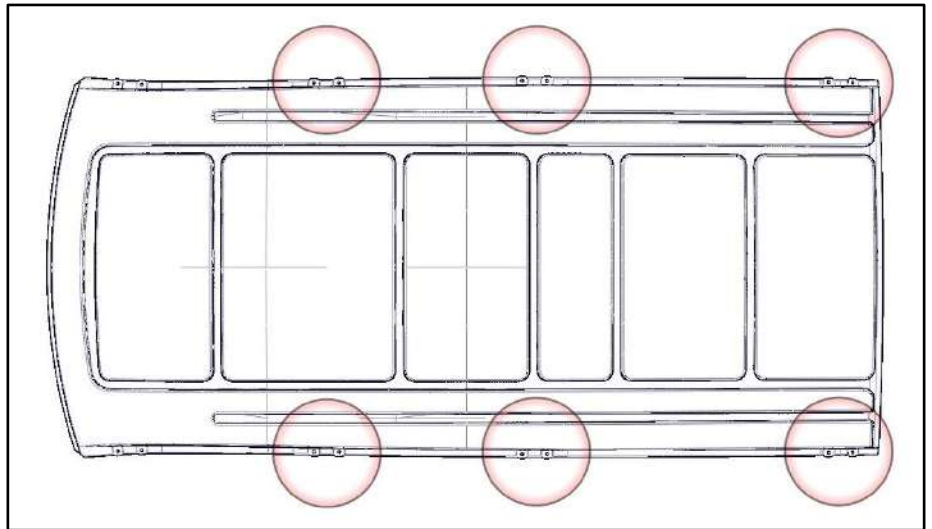

Step 2

- Bolt through the mount foot (B) into the exposed holes in roof using one M6 x 20mm hex head (12), one M6 lock washer (13), one M6 flat washer (14) and a rubber spacer (17). In the order shown.
- Be sure to put rubber spacer (17) in between mount foot (B) and roof of van as shown below.
- Place E6000 between rubber spacer and roof of van and around threads to ensure no water leaks into van. Be sure to apply Anti-Seeze to all threads.

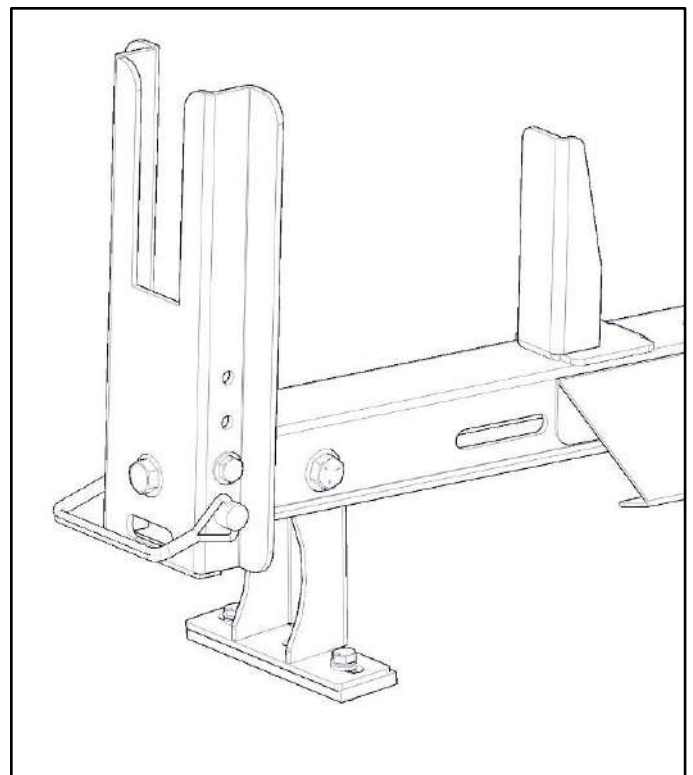
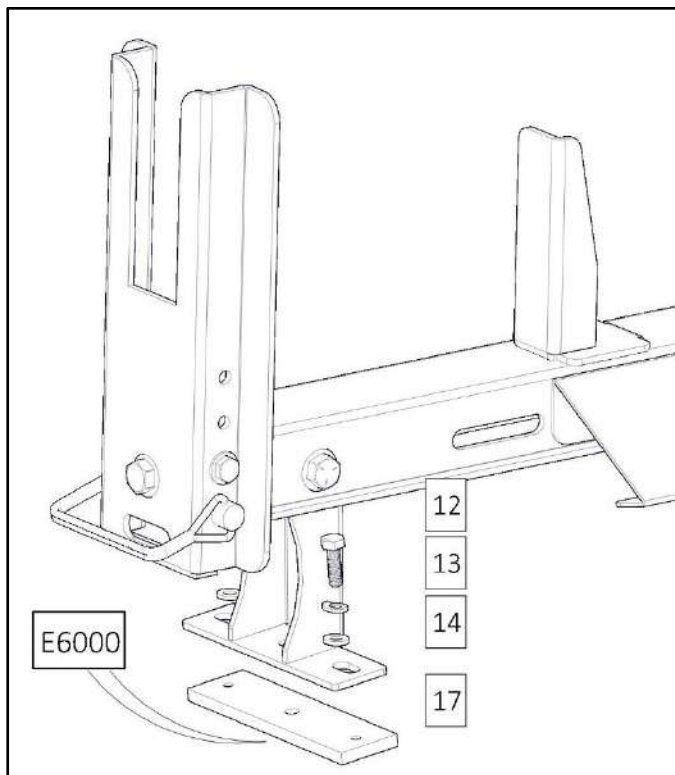

Step 3

- Go back and tighten all bolts including nuts and bolts on the rack itself.

NV

Step 1

- Locate desired mounting location in the roof of van.

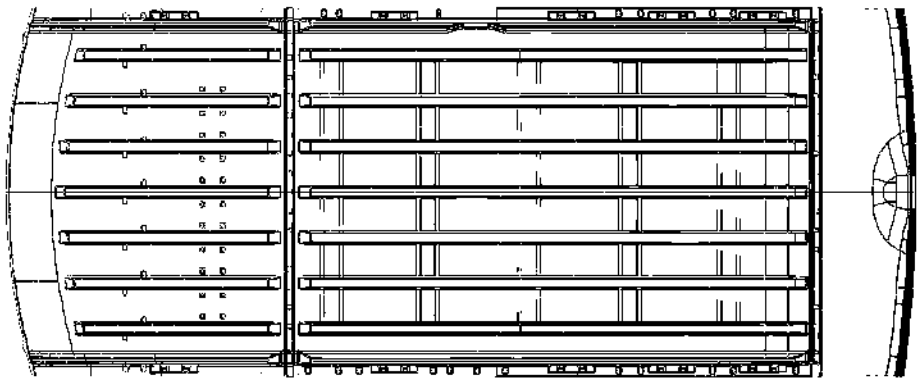

Step 2

- Install M8 U-Nuts (11) as shown. Be sure to apply Anti-Seeze to all threads.

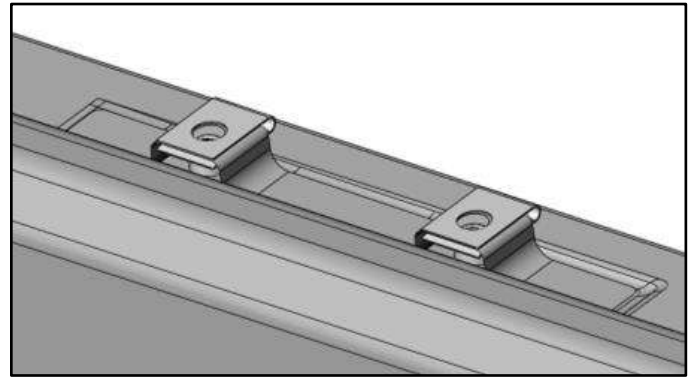
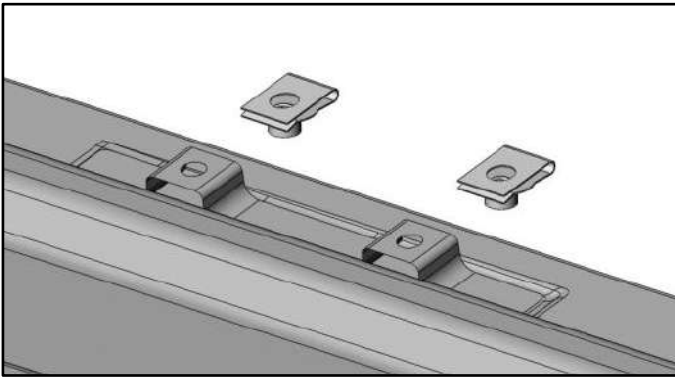

Step 3

- Bolt through the mount foot (B) into the previously installed M8 U-nuts using M8 x 20mm hex head (7), M8 lock washer (8) and M8 flat washer (9).

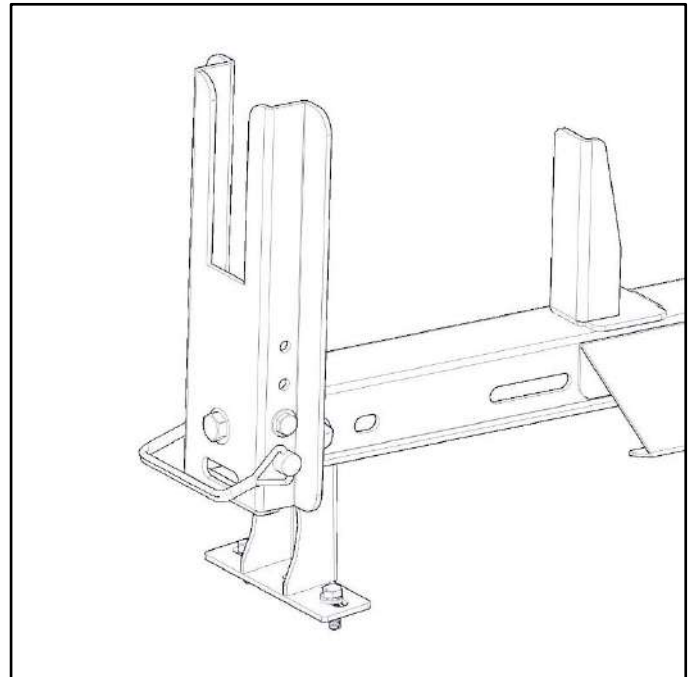
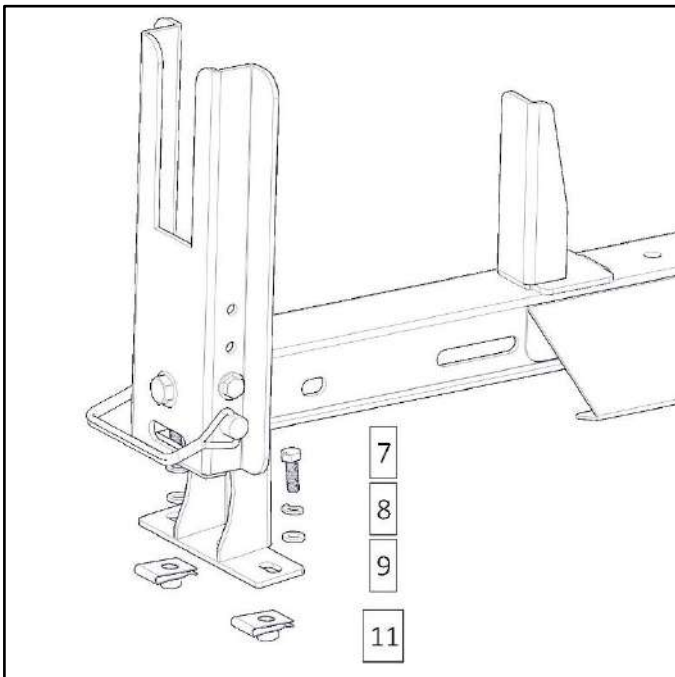

Step 4

- Go back and tighten all bolts including nuts and bolts on the rack itself.