

KARGO MASTER[®]

WE PUT EVERYTHING WITHIN REACH.

Instruction Guide

4A813

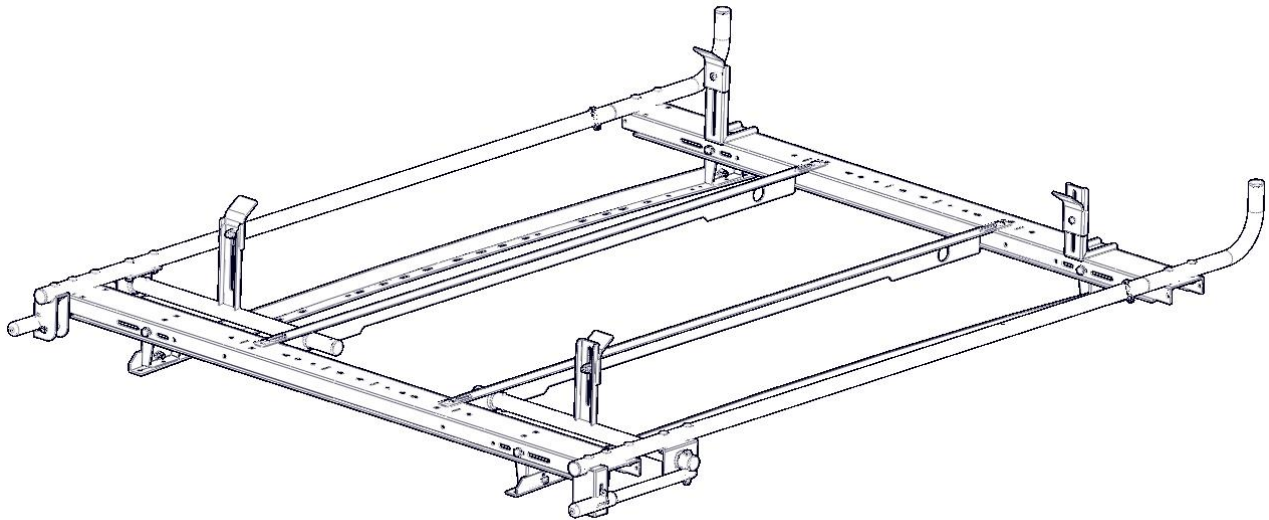

***PLEASE READ ALL INSTRUCTIONS AND WARNINGS PRIOR TO ASSEMBLING,
INSTALLING, AND USING THIS PRODUCT***

Warning



Always check for wires, fuel tanks and lines, brake lines and other important vehicle functionality items prior to drilling and installing all products.

Tools Needed

9/16" Socket and Wrench	1/2" Socket and Wrench
-------------------------	------------------------

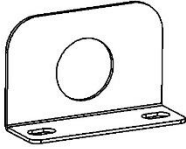
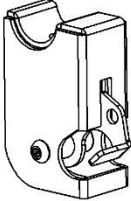
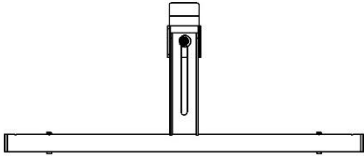

Table of Contents

Parts List	2
Assembly Hardware	3
Step 1 – Remove Ladder Stops	4
Step 2 – Mount Side Tube	4
Step 3 – Mount Clamp Tube	5
Step 4 – Mount Handle	6
Step 5 – Mount Latch Assembly	7
Step 6 – Mount Ladder Hook	7

Before You Begin

- Read all instructions. Find your vehicle roof rail mounting prior to rack assembly.
- Be sure to put E6000 sealant around all threads entering cargo area and between the rubber spacer and roof of vehicle to prevent water from leaking into cargo area.
- **DO NOT EXCEED MANUFACTURERS WEIGHT CAPACITY FOR ROOF**
- **PLACE ANTI-SEEZE ON ALL THREADS**

Parts

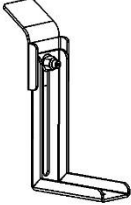
ITEM NO.		PART NUMBER	DESCRIPTION	QTY.
A		4A800-00-003	Clamp and Lock L Bracket	1
B		4A800-00-005	rotation bar plate	1
C		4A800-20	Latch Assy.	1
D		4A800-30	Clamp Tube	1
E		4A800-40	Handle	1
F		4A800-50	Side Tube Assembly	1
G		4A800-60	Ladder Stop Assembly	1
		18-4A813	Hardware - Add on	1

Assembly Hardware (18-4A813)

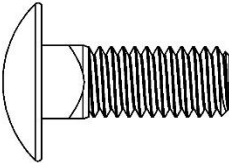
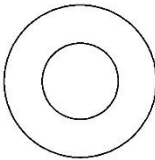
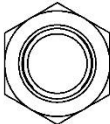
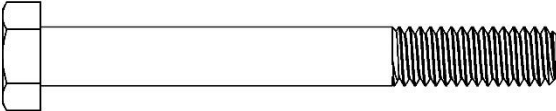
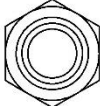
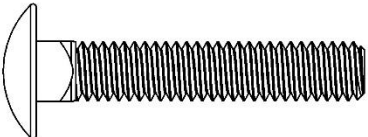
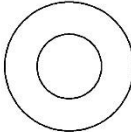
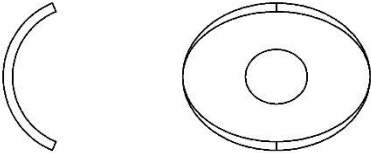
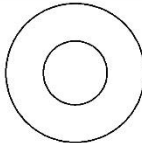
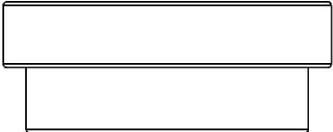
ITEM NO.	TO SCALE	PART NUMBER	DESCRIPTION	QTY.
1		92356A624	.375-16 x 1 Carriage SS	3
2		96659A108	.375 Flat Washer SS	3
3		91831A127	.375-16 Nyloc SS	3
4		92198A694	.312-18 x 2.75 HH SS	1
5		91831A030	.312-18 Nyloc SS	8
6		92356A582	.312-18 x 1.75 Carriage SS	7
7		96659A107	.312 Flat Washer SS	8
8		91844A230	.312 Curved Washer	1
9		90295A160	.06 x .34 x .75 Nylon Washer	1
10		11-03013	11-03013	2
		Anti-Seeze	Anti-Seeze	1
		E6000	E6000	1

Step 1 – Remove Ladder Stops

- If havent already done so, Remove ladder stops from opposite end of both bows where the clamp and lock is installed.

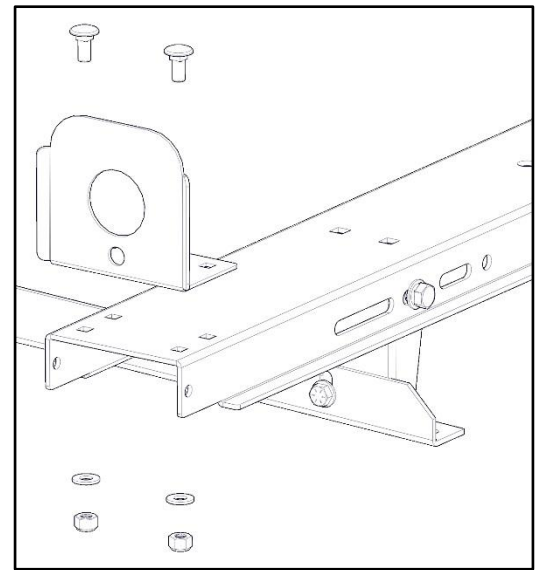
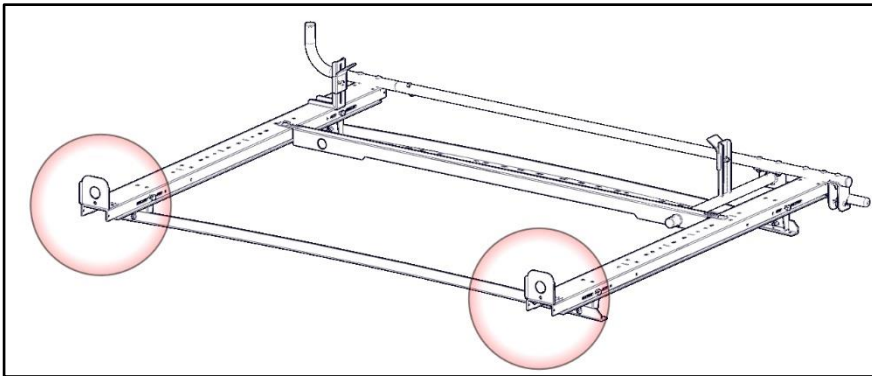

Step 2 – Mount Side Tube

- Place side tube on top of installed bows.
- Have the bend towards the front of the vehicle as shown.
- Mount rotation bar plate to the rear of the tube as shown.
- Leave one square slot open at the rear.
- Bolt together using 5/16 x 1.75 carriage bolt, a 5/16 flat washer and a 5/16 nylock.
- Snug Tighten, but allow movement.

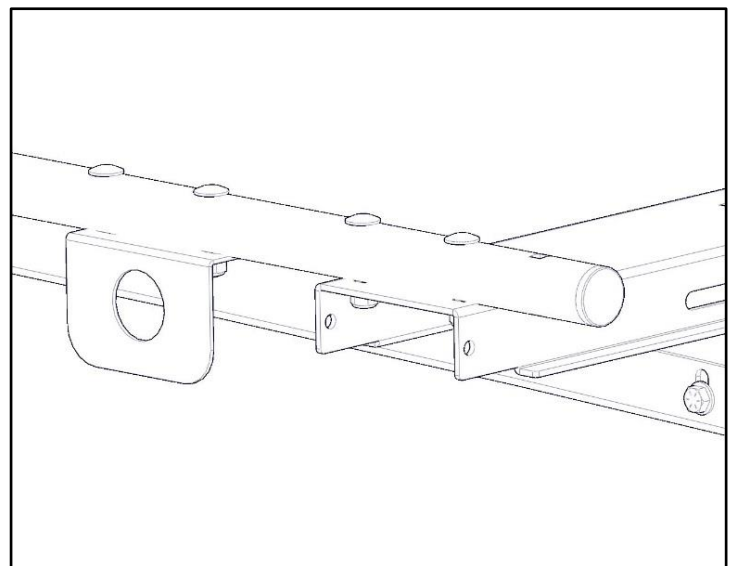
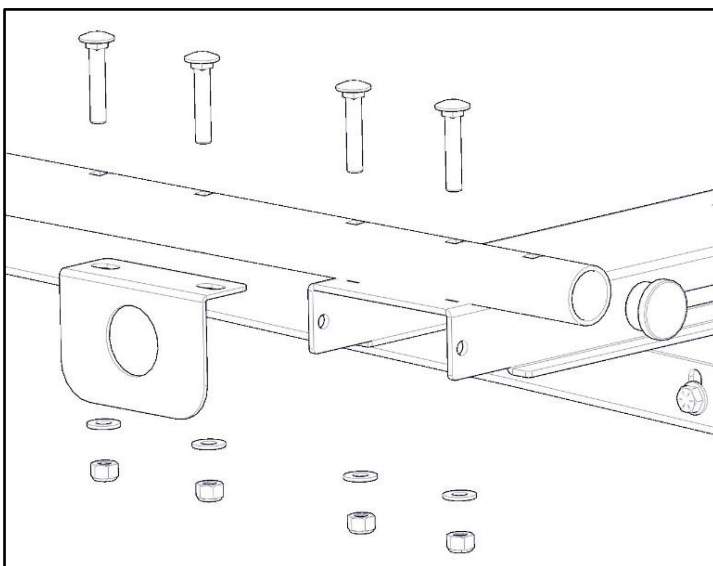
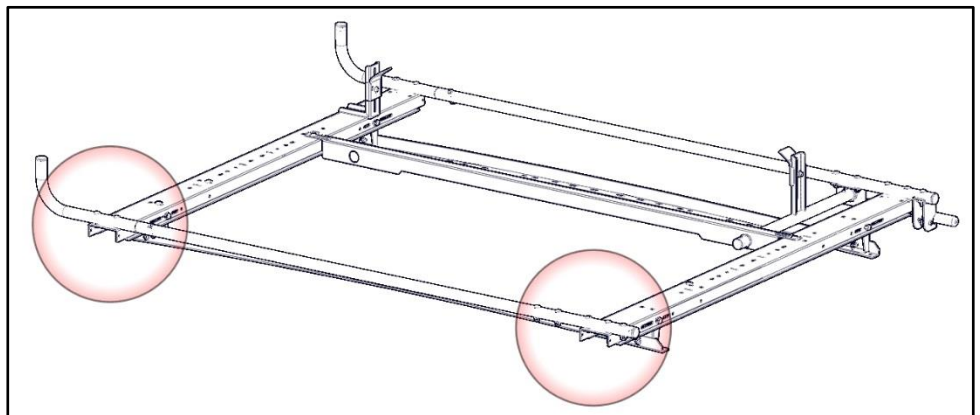

Step 3 – Mount Clamp Tube

- Place clamp and lock L bracket on top of installed bows.

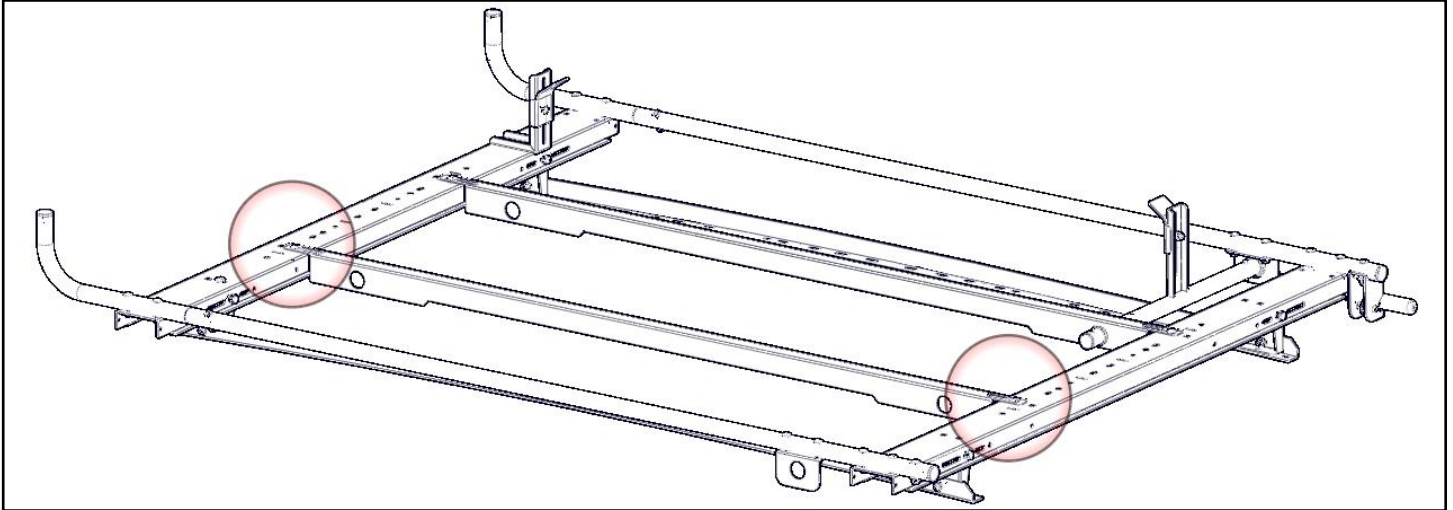

- Insert plastic bushings into the clamp and lock L bracket and the rotation bar plate installed in Step 2, with flange towards each other and to the inside as shown.

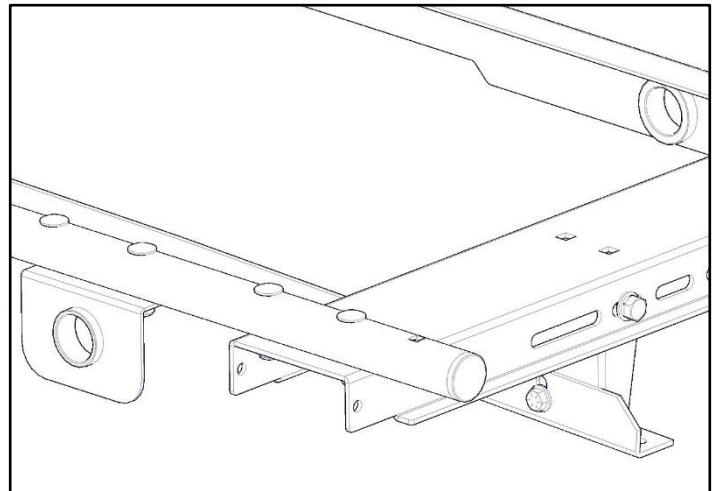
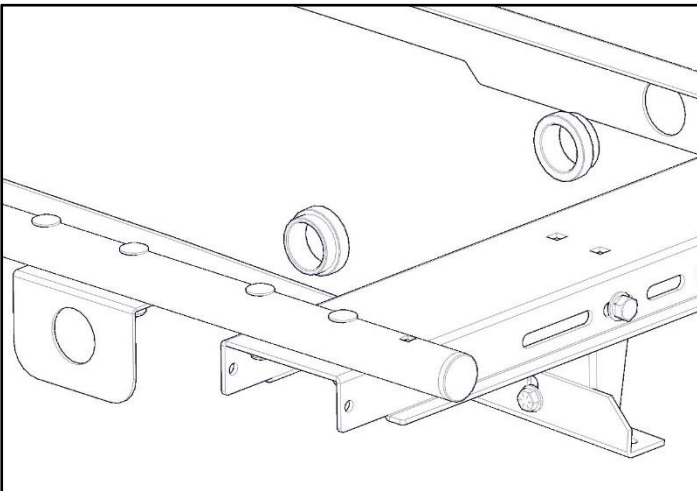

- Insert clamp tube into both plastic bushings.
- Adjust clamp on clamp tube to fit firmly against your ladder.

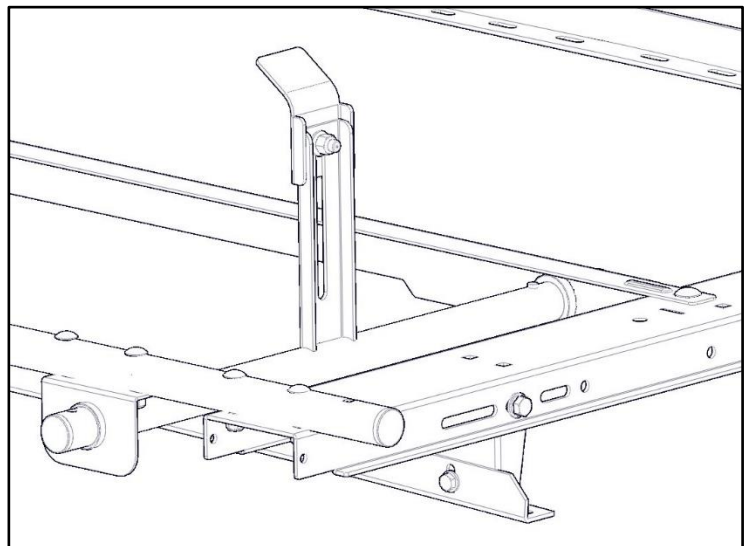
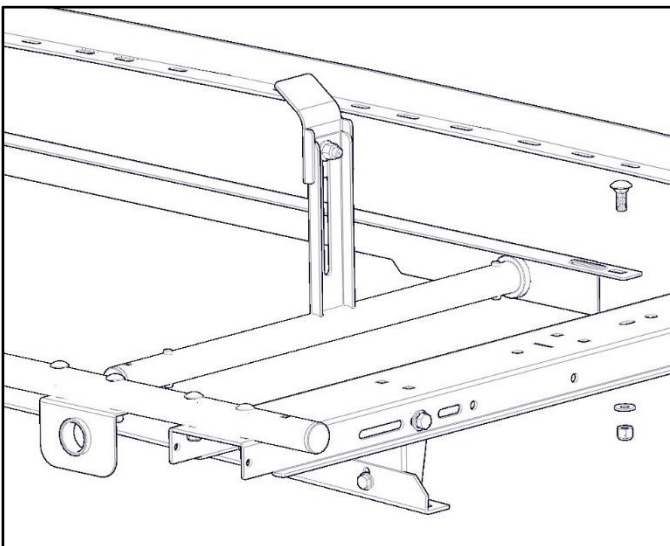

- Bolt clamp and lock L bracket to bows using 3/8 x 1 carriage bolt, 3/8 flat washer and a 3/8 nylock as shown. (This view shown without clamp tube)
- TIGHTEN

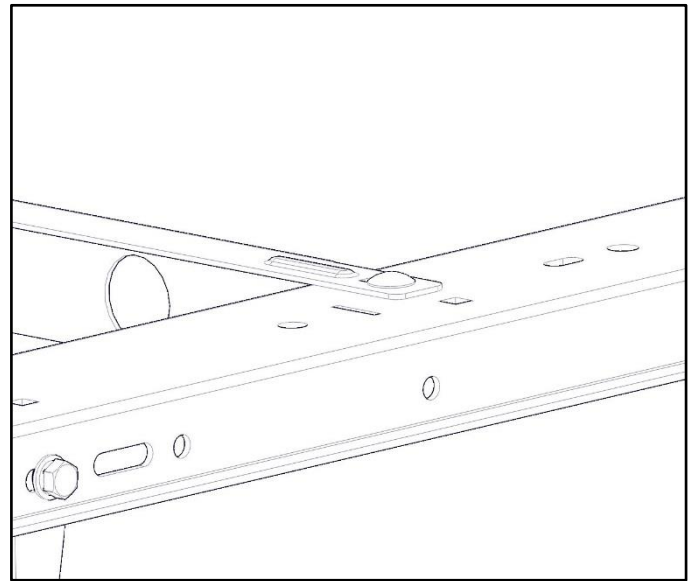
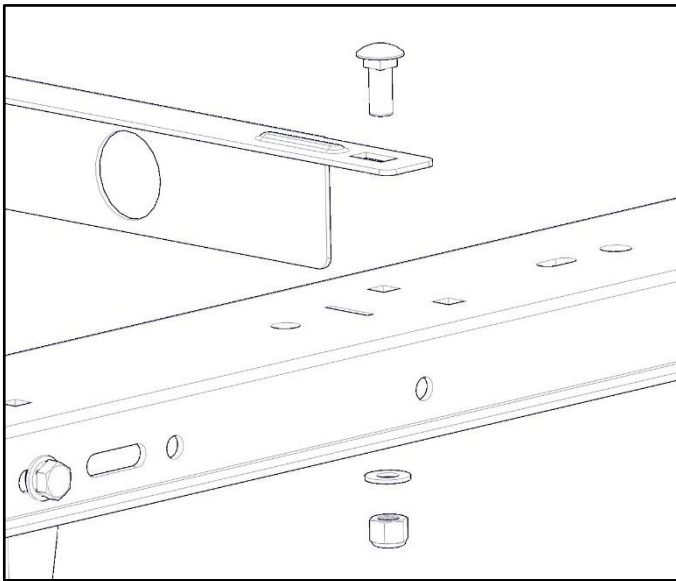

Step 4 – Mount Handle

- Bolt handle to clamp tube using a 5/16 x 2.75 hex head, two 5/16 flat washers, 5/16 nylon washer and 5/16 a nylock. The nylon washer goes in between the clamp tube and handle.
- TIGHTEN

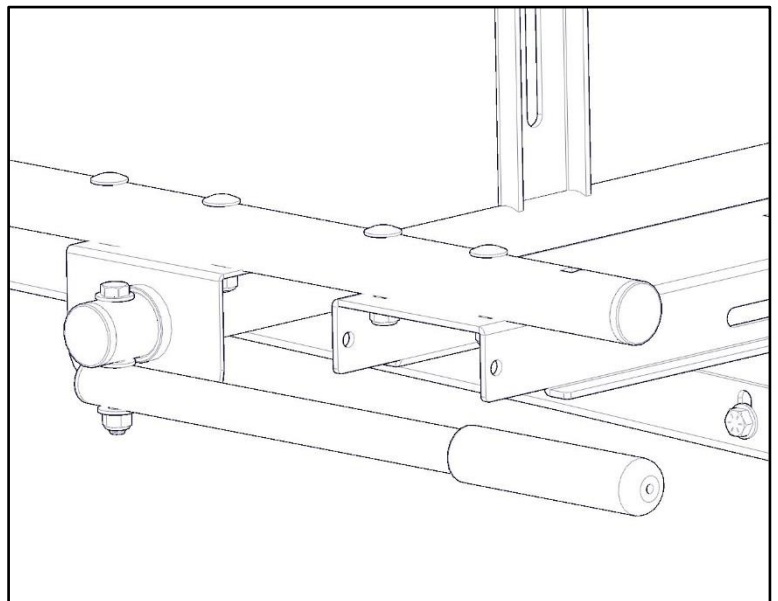
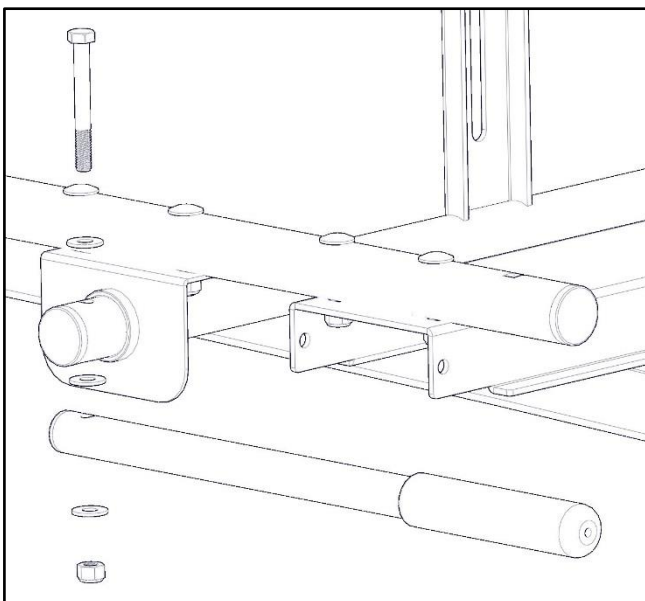

Step 5 – Mount Latch Assembly

- Bolt latch to the rear of the mount tube that was installed in Step 5 using 5/16 x 1.75 carriage bolt, 5/16 curved washer and a 5/16 nylock.
- TIGHTEN

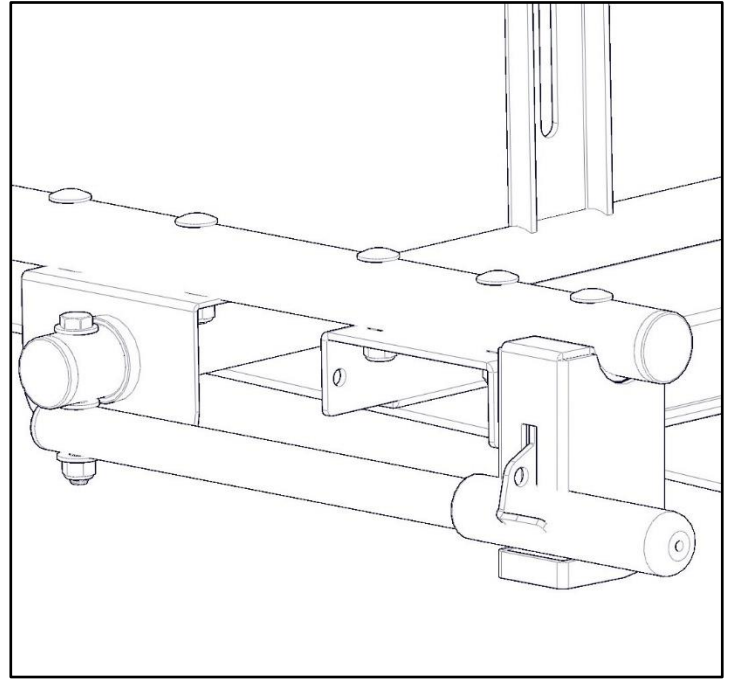
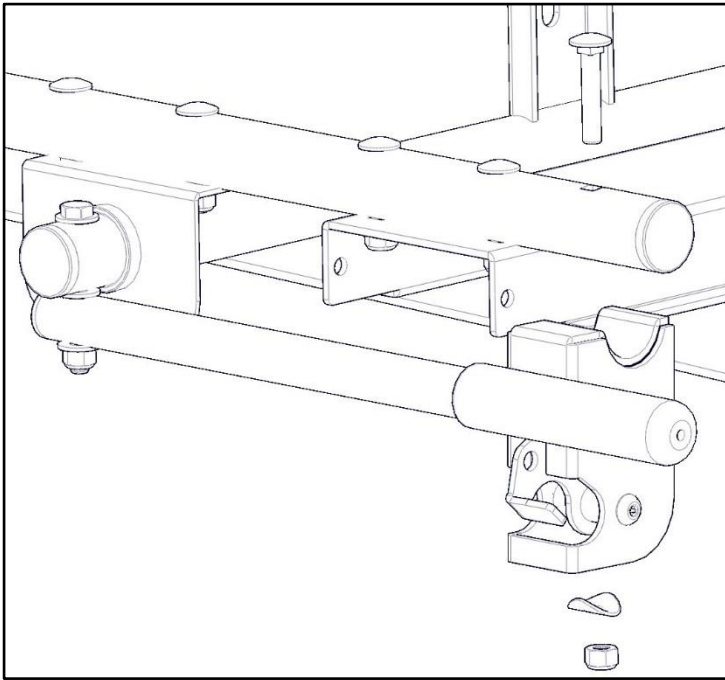

Step 6 – Mount Ladder Hook

- Bolt ladder hook bracket to the bow in the orientation shown using a 3/8 x 1 carriage bolt, a 3/8 flat washer and a 3/8 nylock. Be sure the bracket is square to the bow.
- Adjust clamp on bracket to fit firmly against your ladder.
- TIGHTEN

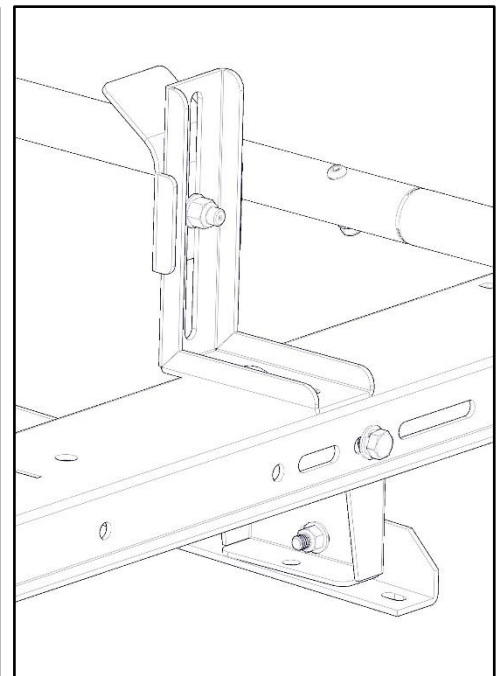
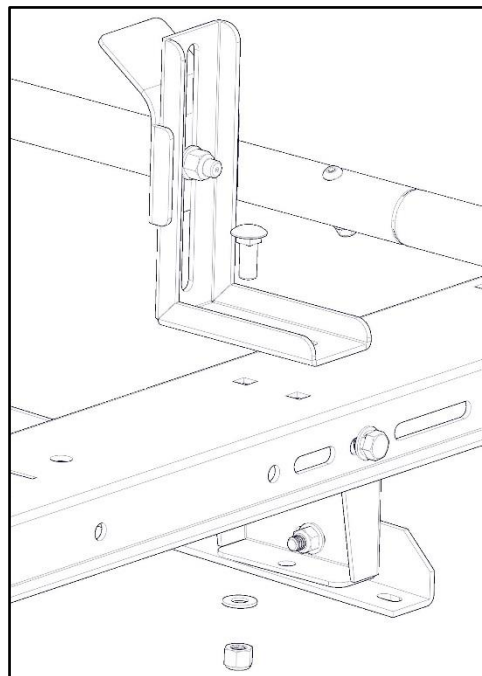

GO BACK AND ENSURE ALL HARDWARE IS TIGHT
Your installation is now complete.

KEEP THIS GUIDE WITH VEHICLE AT ALL TIMES

* PLEASE READ INSTALLATION INSTRUCTIONS FOR FURTHER ASSEMBLY AND USE INFORMATION. *

**** DO NOT install ladder until ladder hook orientation and position are adjusted. ****

**** ALWAYS ENSURE LADDER IS SECURED TO TOP OF RACK BEFORE MOVING VEHICLE. ****

Tools Needed 9/16" Wrench and Socket

Step 1 - Loosen bolt on front and rear ladder stops. Adjust ladder stop up. Tighten nuts.

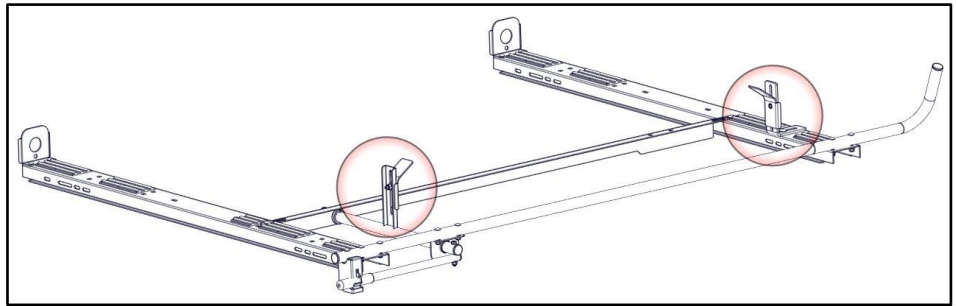

Step 2 - Loosen the bolt that secures the front ladder stop to the cross member.

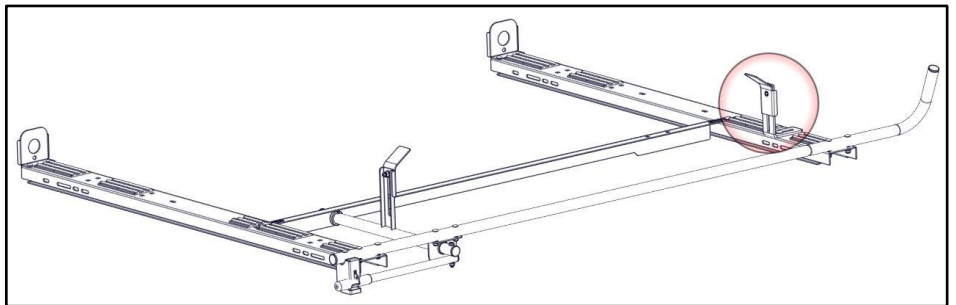

Step 3 - Lower the clamping mechanism.

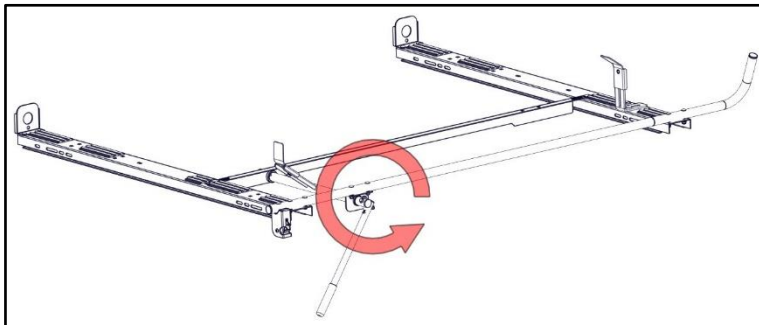

Step 4 - Load ladder onto rack and adjust ladder about where you want ladder to sit on rack.

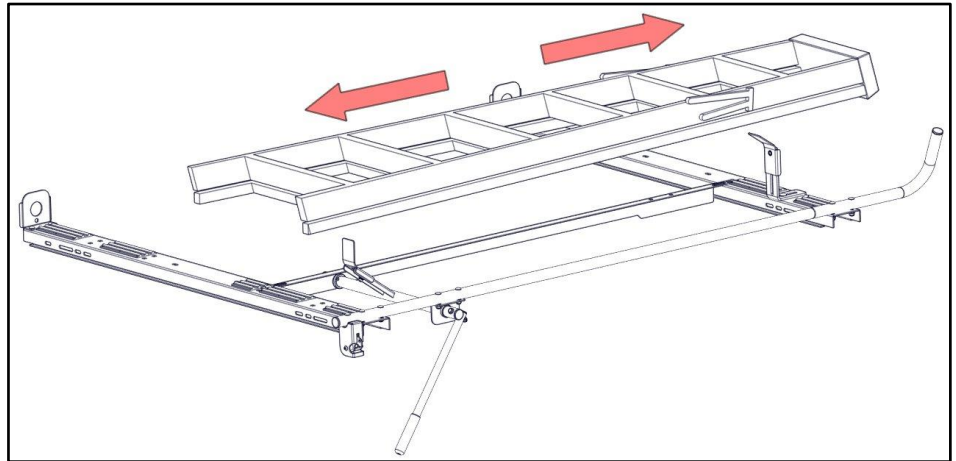

Step 5 - Raise clamping mechanism and stow handle into the rack.

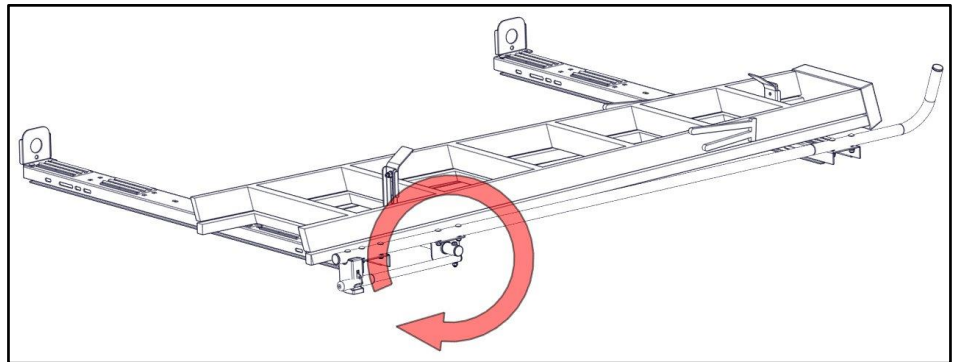

Step 6 - Push ladder to rear so rung sits flush against clamping mechanism.

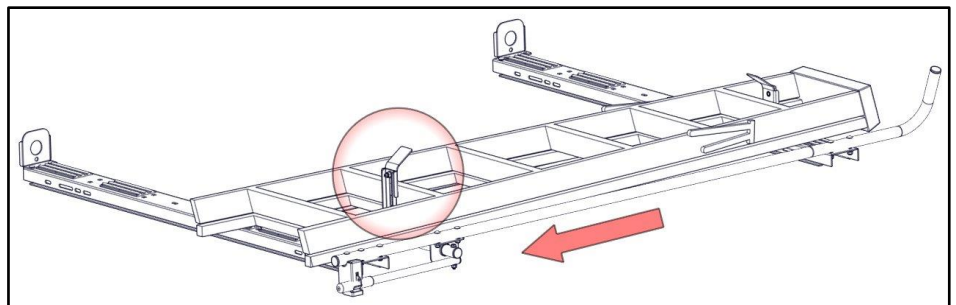

Step 7 - Loosen bolt on angled pad and adjust downward until firmly against top of ladder. Tighten nut.

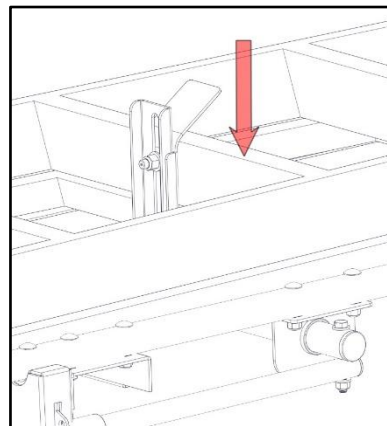

Step 8 - Adjust front ladder stop tight against rung and tighten bolt and nut to cross member.

**** BE SURE THE LADDER HOOK IS FIRMLY AGAINST TOP LADDER STEP OR RUNG. ****

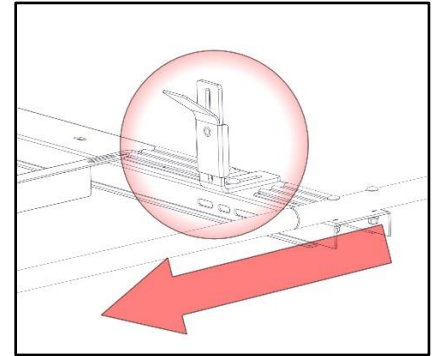
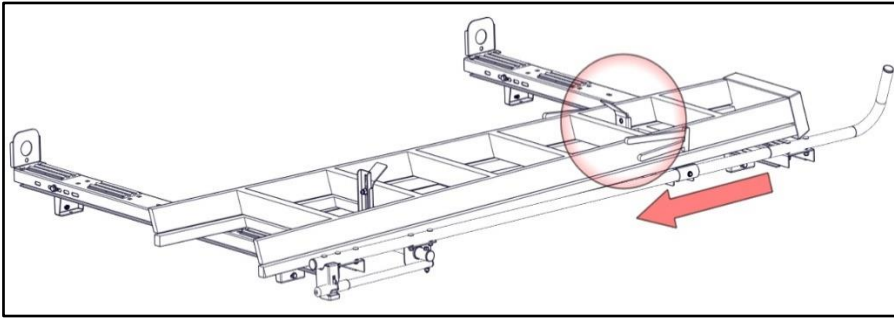

Step 9 - Loosen nut on front ladder stop angled pad. Adjust pad downward and firmly against ladder. Tighten nut.

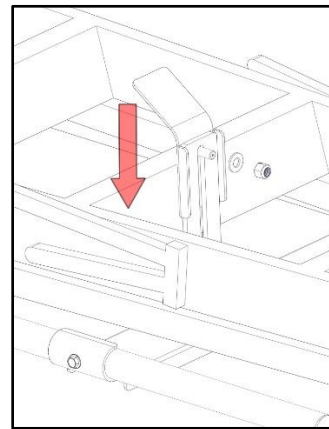

**** BE SURE TO HAVE FIRM CONTACT ON BOTH LOCATIONS SHOWN BELOW ****

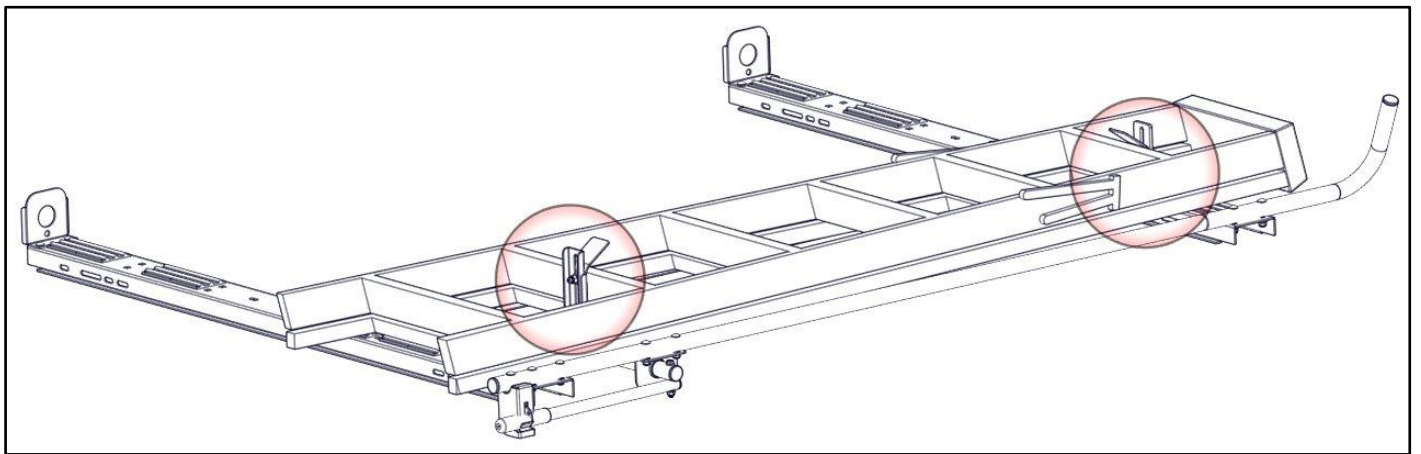

EXAMPLES OF LADDER CLAMPS FIRMLY AGAINST LADDER RUNGS

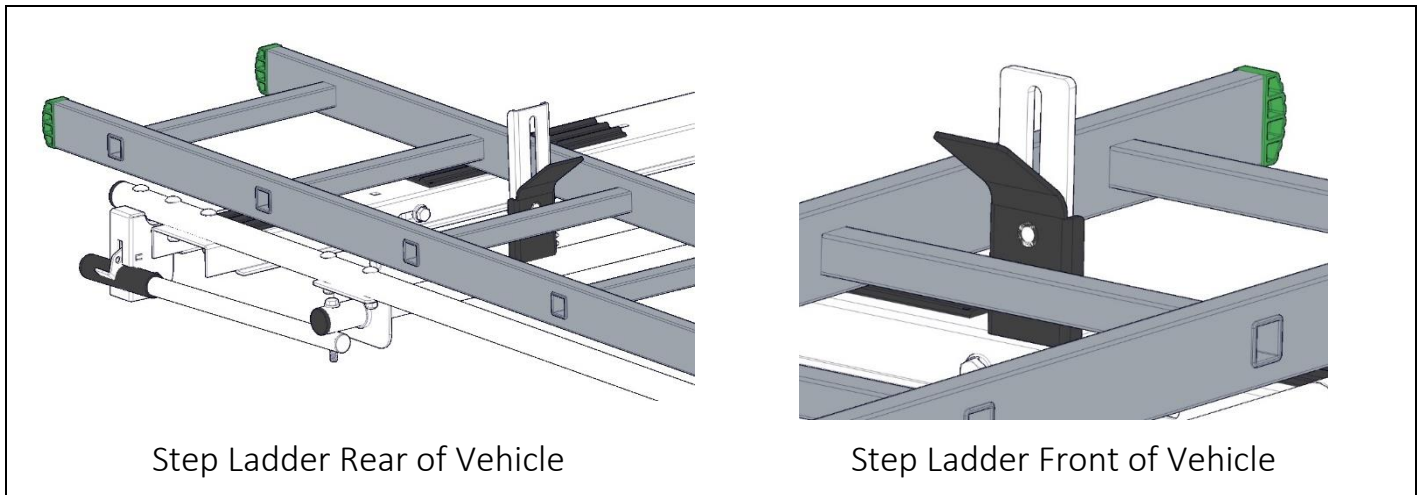

* Ladder hook must be positioned so hooks clamp ladder tightly into place. *

Front Clamp-Different Clamp Orientations

Orientation may differ depending on ladder size and type.

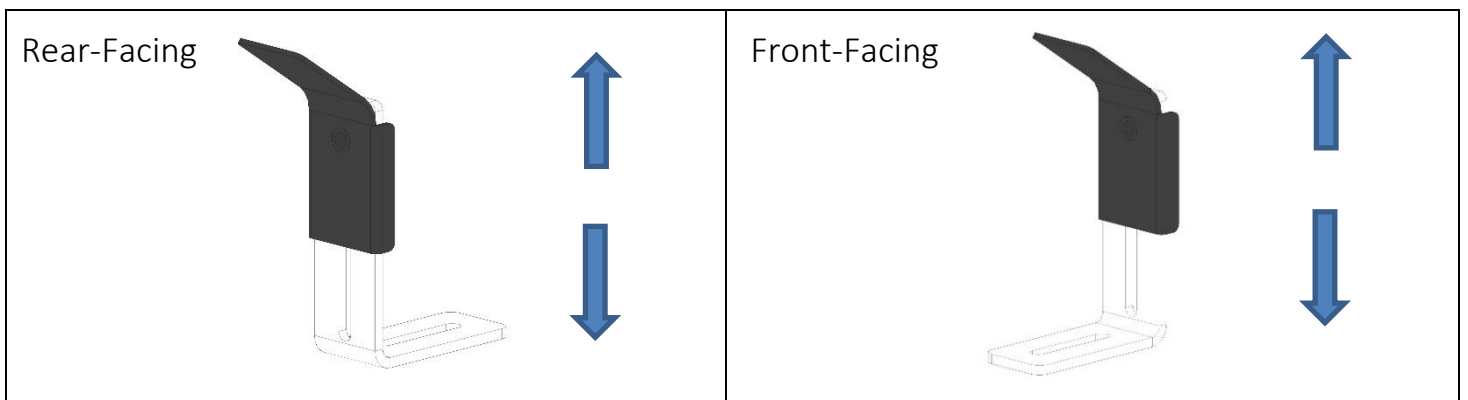

Rear Clamp-Different Clamp Orientation

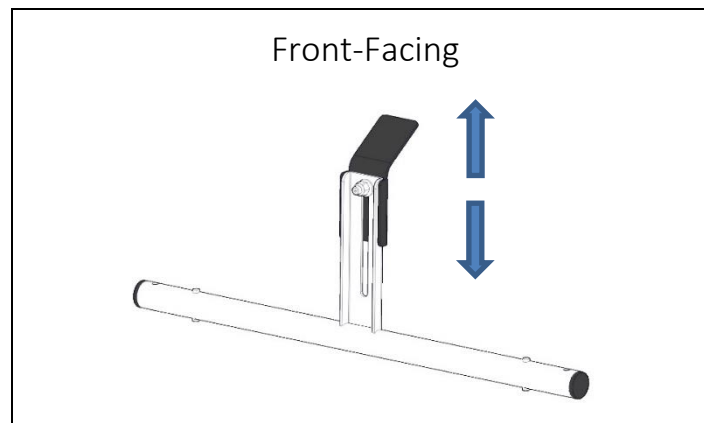

**** ALWAYS ENSURE LADDER IS SECURED TO TOP OF RACK BEFORE MOVING VEHICLE. ****

* Securing ladder to rack with additional tie-down during transport is recommended. *

Discover other commercial van equipment on our website.